

SWISS MODULAR[®]

by Triag International AG

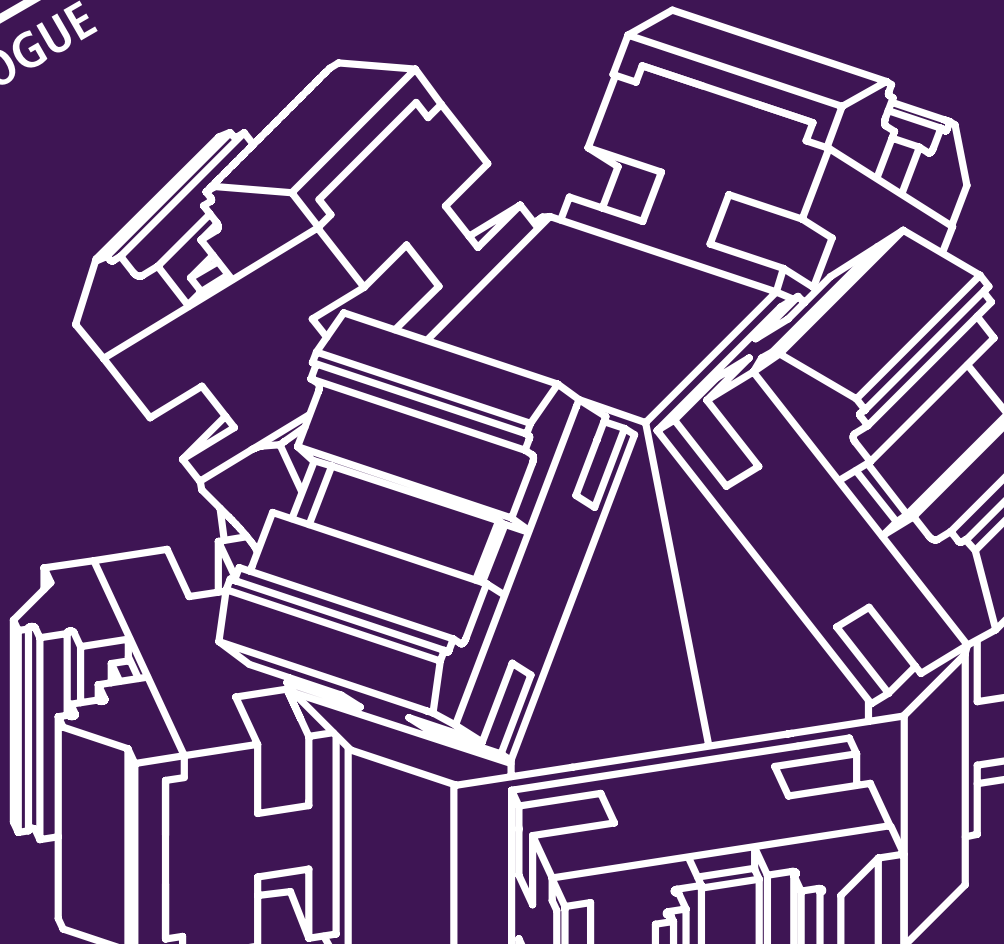

Inhalt Content

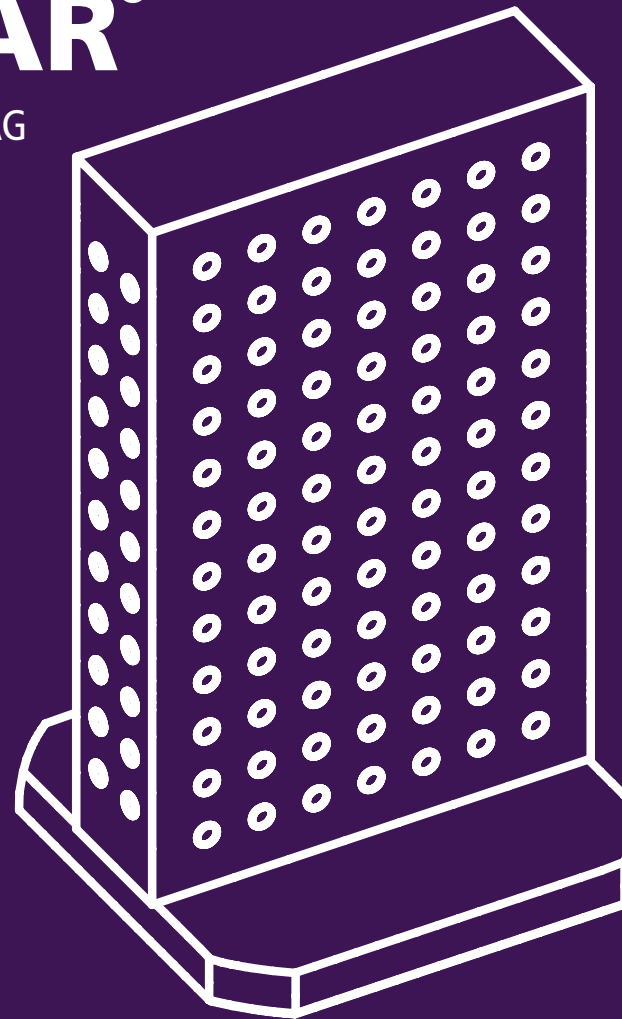
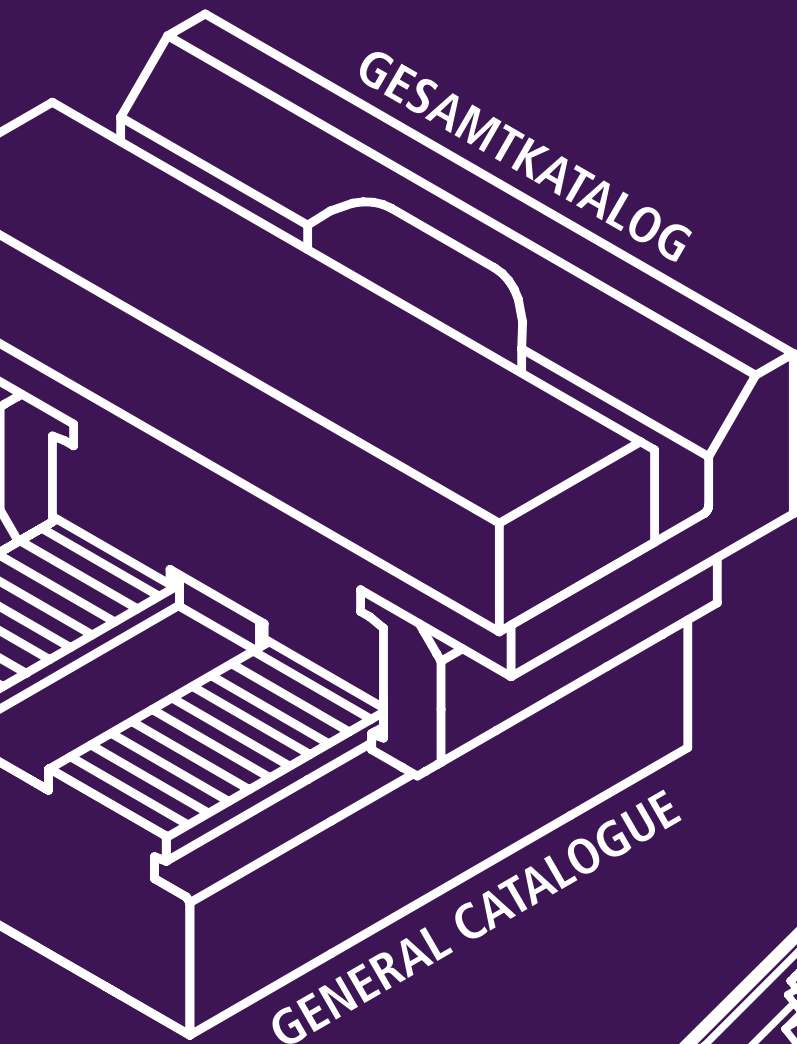

powerCLAMP

13 - 112

Der Lego-Schraubstock 3D Modular
The lego-vise - 3D modular



triCENTRO

113 - 162

Modulare Zentrischspanner
Modular self centering vises



microCLAMP

163 - 206

Spannmodule für den Vorrichtungsbau
Clamping modules for dedicated fixtures

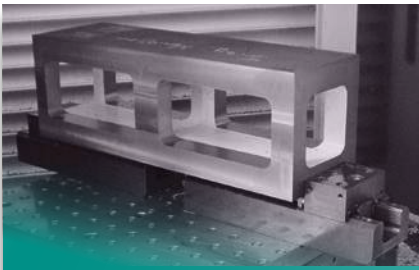

aptoCLAMP

207 - 234

Das stärkste Spannsystem
The strongest workholding system

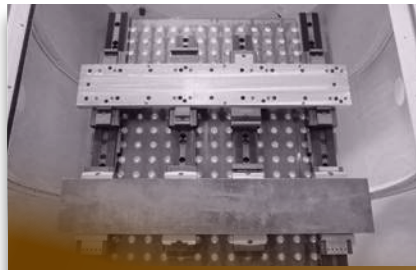

tripoxyMINERAL

235 - 278

Eliminiert Vibrationen und ist leicht
Eliminates vibrations and is low in weight

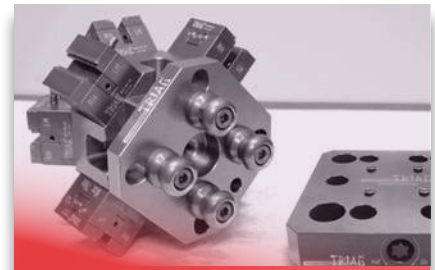

oppSYSTEM

279 - 302

Schneller Umrüsten mit Nullpunktsystemen
Zero point - quick change systems

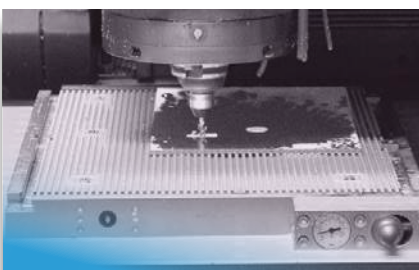

trivaCLAMP

303 - 328

Spannen mit Vakuum
Clamping with vacuum



SPECIALS

329 - 332

Sondervorrichtungen
Custom made fixtures



Zubehör / Accessoires

333 - 340

INDEX

341 - 346

Über uns About us

1990 Die Triag AG wurde im Jahr 1990 von Edi Zängerle, Ursula Landtwing und Beat Baumgartner gegründet. Sie vertrieb ihre Spannsysteme sowie Zerspanungswerkzeuge namhafter Hersteller hauptsächlich auf dem Schweizer Markt.

2013 Am 1. Juli 2013 wird die Firma in die zwei Unternehmen Triag AG und Triag International AG aufgesplittet.

HEUTE Wir, die Triag International AG, konzentrieren uns seither auf die Entwicklung, Produktion sowie den weltweiten Vertrieb unserer modernen Spannsysteme. Sowohl mit unserem tiefen und breiten Standard Sortiment, als auch mittels werkstückspezifischen Sonderlösungen möchten wir unseren Kunden dabei helfen, ihren Maschinenraum optimal auszunutzen, um dadurch die grösstmögliche Effizienz zu erzielen. Unsere Spannsysteme können von der konventionellen Fräsmaschine bis hin zu modernen 5-Achs-Fräszentren mit oder ohne Automatisierung eingesetzt werden. Diese Effizienz nutzen wir auch in der Herstellung unserer Spannsysteme in unserer eigenen Fertigung. Das gesamte Sortiment an Spannsystemen und Mineralgusstürmen läuft seit 2023 unter der Marke swissMODULAR.

Auf ein gutes Arbeitsklima und unsere Umwelt legen wir sehr grossen Wert, denn nur mit einem funktionierenden Team und einem grossen Umweltbewusstsein können wir unsere Kunden offen und nachhaltig bedienen.

1990 Triag AG was founded in 1990 by Edi Zängerle, Ursula Landtwing and Beat Baumgartner. Triag AG distributed its clamping systems as well as cutting tools of well-known manufacturers primarily on the Swiss market.

2013 On July 1st, 2013, the company has been split up into the two companies Triag AG and Triag International AG.

TODAY Triag International AG concentrates on the development, manufacturing and worldwide distribution of our/its modern clamping systems since. With our wide range of standard products as well as by means of custom-built solutions we aim to help our customers to get the most out of their machine space in order to achieve the highest efficiency possible. Our modular workholding systems can be applied from conventional up to 5-axis milling machines, with or without automation. We benefit of this efficiency in the manufacturing of our clamping systems in our own production too. Since 2023, the whole range of clamping systems and epoxy mineral tombstones runs under the brand swissMODULAR.

We focus on a good working atmosphere and place great value on our environment. We believe that these factors are essential to provide an open and sustainable service.

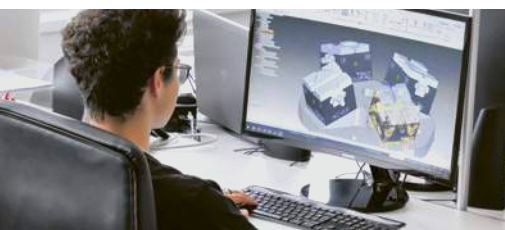

**Triag Internationa AG
laucht die neue Marke
swissMODULAR.
Die Marke umfasst das
gesamte Sortiment an
Spannsystemen und
Mineralgusstürmen**

**Entstehung der Triag
International AG und
der Schwesterfirma Tribur
Invent GmbH, die sich auf
den weltweiten Vertrieb
mit eigenem Engineering,
eigener Produktion und
eigener Mineralguss
Giesserei konzentrieren.**

Gründung der Triag AG

2023

**Triag International AG has
rebranded to swissMODULAR.
The new brand includes the
whole range of clamping
systems and epoxy mineral
tombstones.**

2013

**The formation of Triag
International AG and
the sister company Tribur
Invent GmbH, which are
focusing on worldwide
distribution with their own
engineering, manufacturing
and epoxy mineral casting.**

1990

Foundation of Triag AG

Im Herzen der Schweiz
In the heart of Switzerland

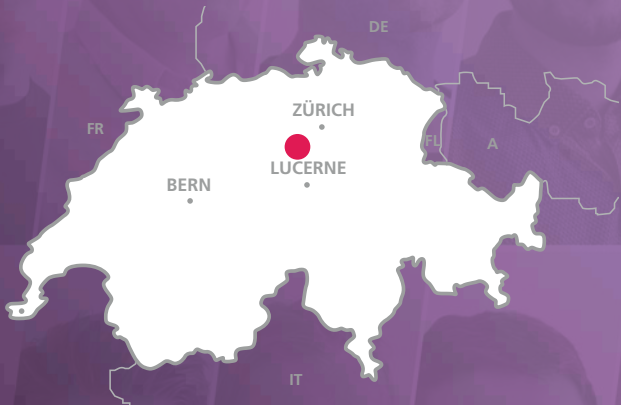
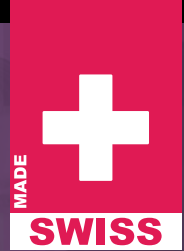

Triag International AG

Bösch 84 CH-6331 Hünenberg

☎ +41 41 727 27 77

✉ spannen@triag-int.ch

✉ clamping@triag-int.ch

www.triag-int.ch



Langfristige Kundenbeziehungen
Long-term customer relations

Respektvolle Teamarbeit
Respectful teamwork

Lehrlingsausbildung
und faire Lohnpolitik
*Apprenticeship and
fair wage policy*

swiss 
MODULAR[®]

by Triag International AG

Erstklassige Qualität
zu fairen Preisen
*First class quality
with fair pricing*

Wir respektieren unsere Umwelt
We respect our environment



Time to say goodbye
to the dinosaur vises!



RAUM SPACE

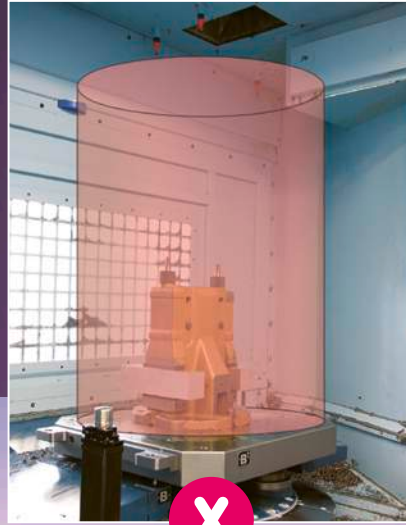

«In Gebäuden ist es doch auch üblich, den Raum komplett zu vermieten. Wieso nicht auch in Ihrer Maschine?»

«In buildings, it is common to rent out the full space. Why not in your machine?»

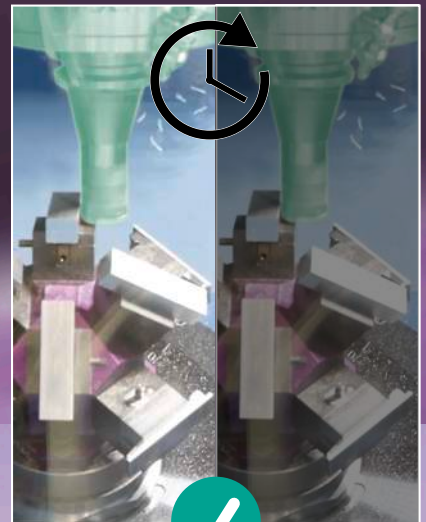

«Flugzeuge sollen möglichst kurze Zeit geparkt bleiben. Das gleiche gilt für die Frässpindel.»

«Aircrafts should remain parked for the shortest amount of time. The same rule applies to the milling spindle.»



Die Effizienzreserven
The efficiency reserves

swiss 
MODULAR[®]

MUESLI CEREAL



«Eine gute Mischung gibt ein gutes Müesli, warum dann nicht auch beim Fräsen?»

«A good mixture makes a good cereal, so why not also when milling?»

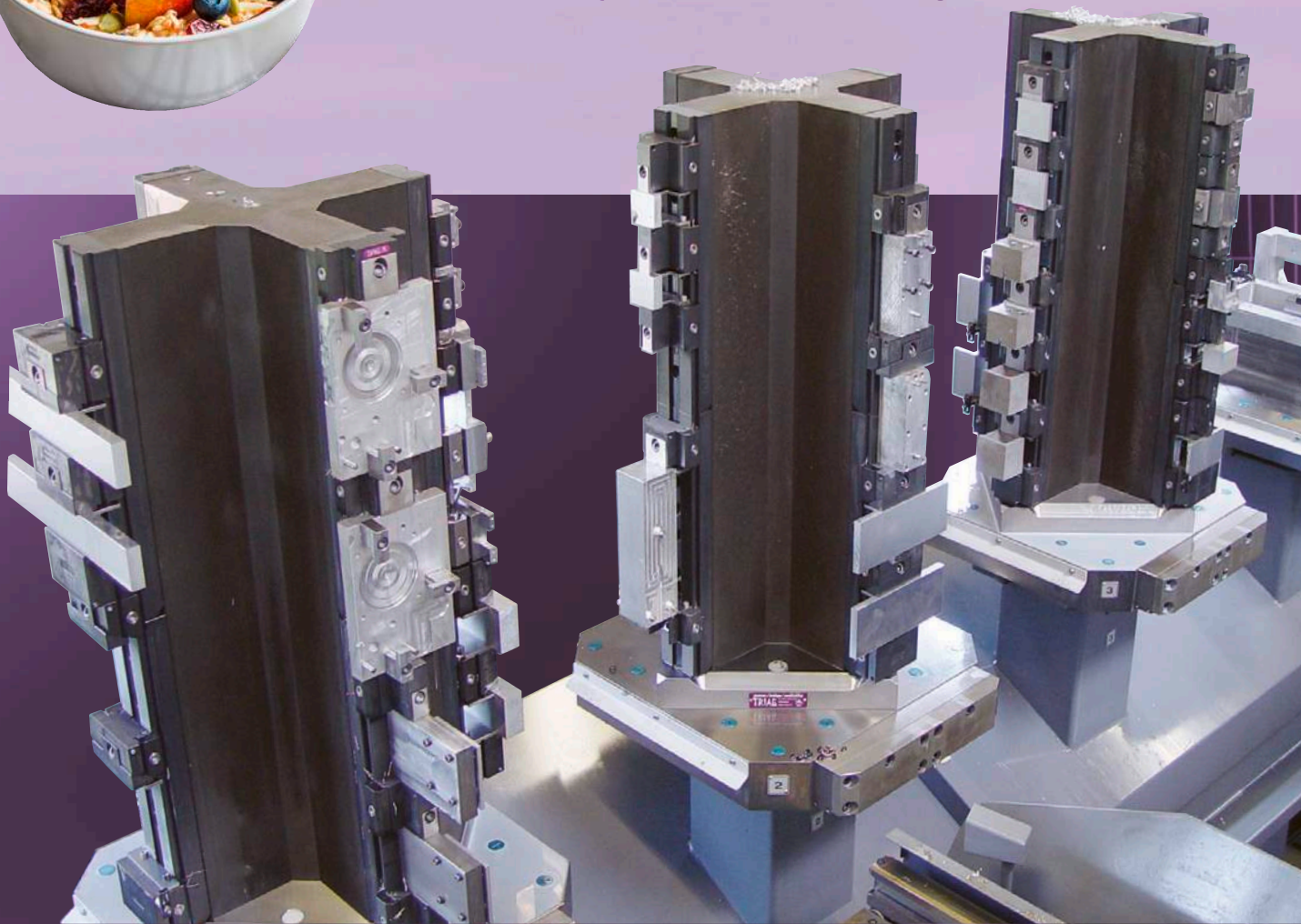

**CHAOTISCHE
PRODUKTION**

**MIXED
PRODUCTION**

«Modular» bedeutet:

3 dimensionales Anpassen an Werkstück und Maschine

Vorteile des modularen Mehrfachspannens:

- Möglichkeit der chaotischen Produktion
- Schneller Werkstückwechsel
- Vielseitigkeit durch Kombination mehrerer Komponenten, 3D modular (Schienen, mechanisch oder hydraulisch betätigte Spannelemente etc.)
- Einfache Montageprozesse
- Lange Lebensdauer, geringe zusätzliche Instandhaltungskosten
- Beschädigte Komponenten können einfach ersetzt werden
- Längere unbemannte Laufzeit
- Deutlich weniger Werkzeug- und Palettenwechsel
- Schont die Maschine, da der gesamte Bearbeitungsraum genutzt wird
- Preis: Kann trotz der Vorteile mit einem Spannstock mithalten
- Geringerer Aufwand in der Logistik, Lagerhaltung und Beschaffung
- Höhere Spanndichte, mehr Teile aufgespannt
- Spannen von kleinen wie grossen Werkstücken

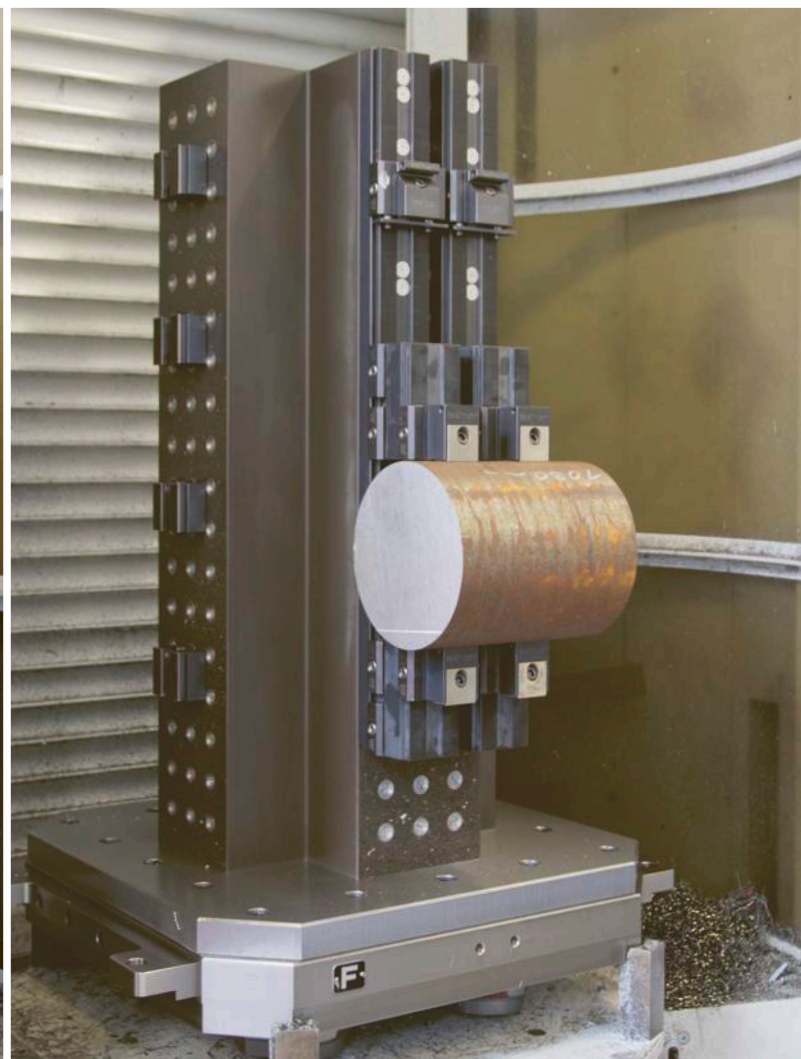
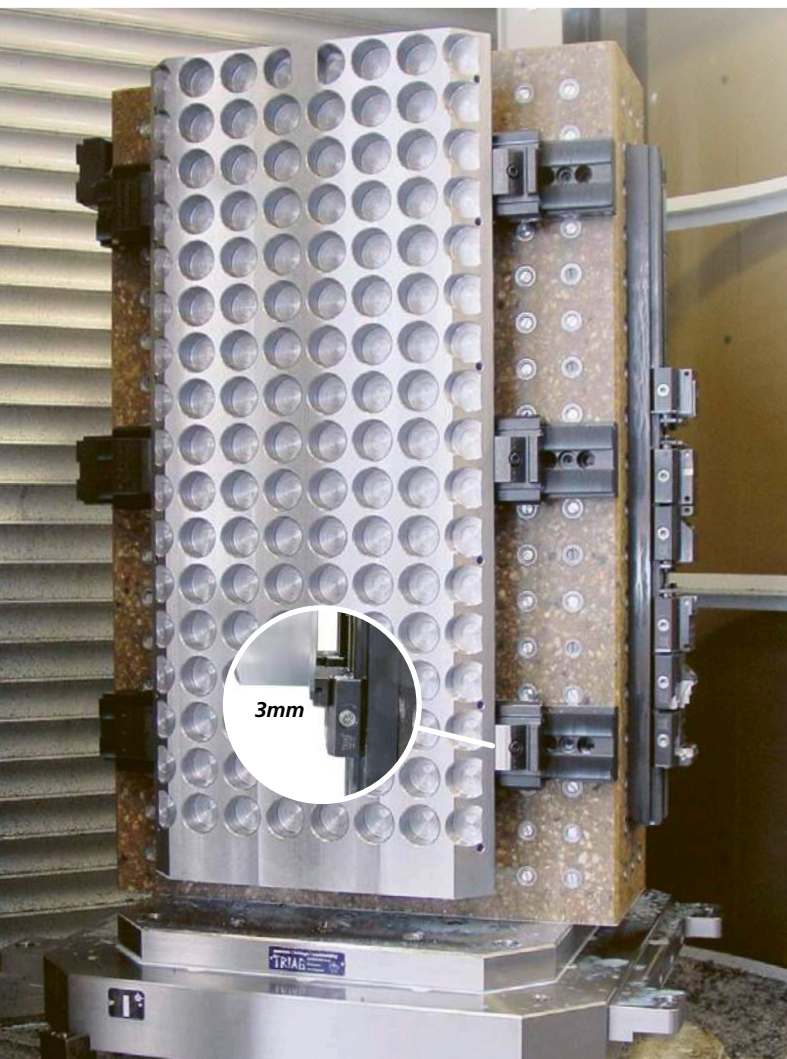

«Modular» means:

Adapting to workpiece and machine situation in 3 dimensions

Advantage of modular workholding:

- Possibility of chaotic manufacturing
- Fast workpiece change
- Flexibility because of different components, 3D modular
- Simple to set up
- Cost effective
- Easy to replace spare parts
- Long unmanned production
- Less tool changes
- The machines are used in the whole working area
- Competitive price to standart vises
- Simple to be purchased and used on different machines
- High density workholding, you clamp more parts!
- Long and reliable live with low maintenance cost

Chaotische Spannung für das Erledigen von verschiedenen Jobs gleichzeitig.
Optimale Nutzung eines Horizontal-Bearbeitungszentrums.

*Mixed set up on a Mazak horizontal machine with
18 pallets. This is used for unmanned production of
small quantities of different materials.*

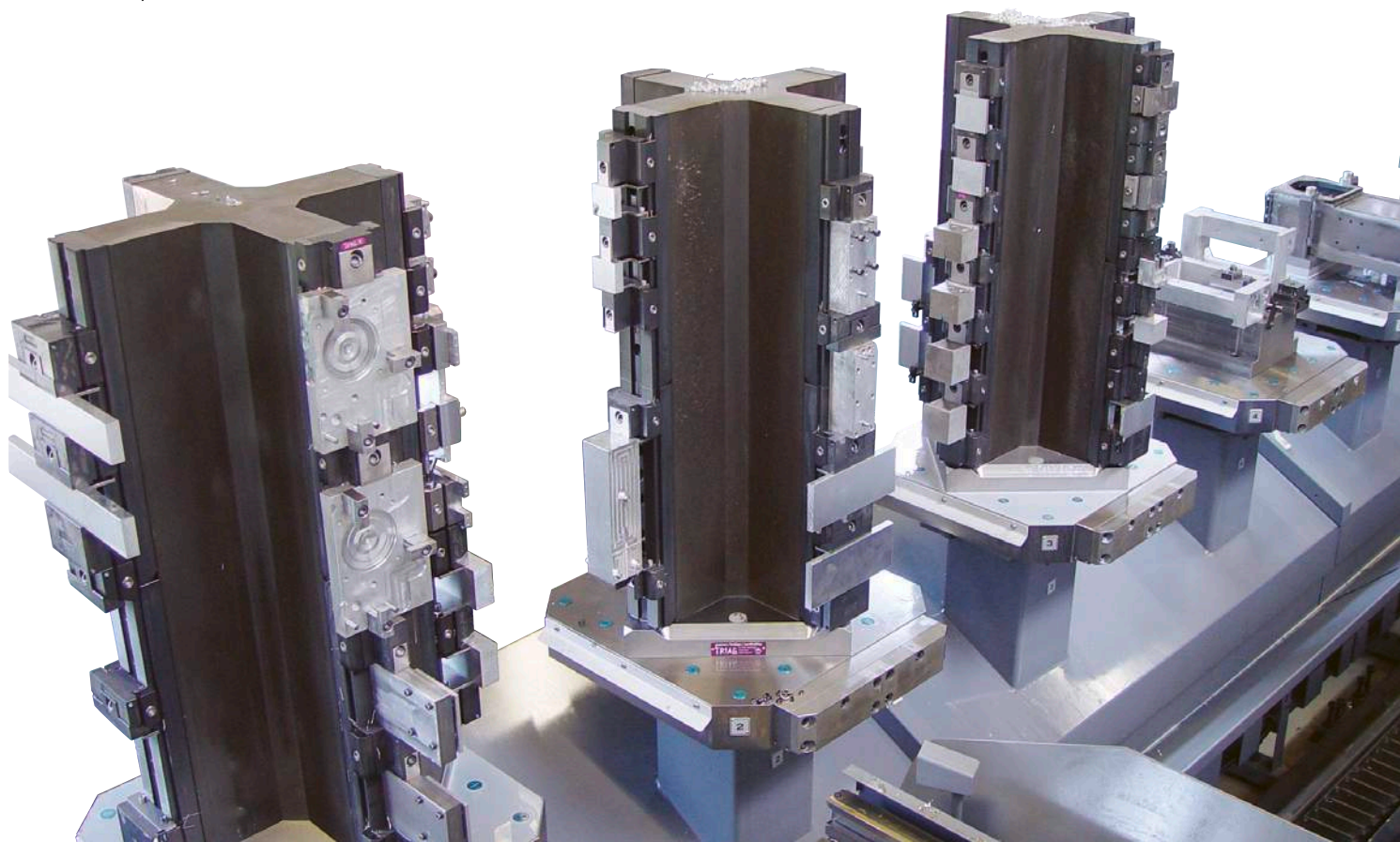

Modulare Mehrfachspannsysteme werden in ihrer Bedeutung für die Zerspanung noch immer unterschätzt. Dabei sind sie sowohl in der Einzelteilfertigung als auch für Grossserien flexibel einsetzbar. Zurückzuführen ist diese Flexibilität auf das Konstruktionsprinzip der Systeme, ihre handhabbare, kompakte Bauweise wie auch die hohe Spannkraft und Spanndichte.

Bei der Beurteilung modularer Mehrfachspannsysteme gibt es eine eigentümliche Konstellation: Zum einen sieht der Einzelteil- und Kleinserienfertiger enorme Vorteile für die Anwendung in der Serienfertigung, beispielsweise rückbaubarer Vorrichtungsbaukasten. Zum anderen erkennt der Serienfertiger genau diese Vorzüge für die Einzelteil- und Kleinserienfertigung. Diese Sichtweise zu hinterfragen und zu verdeutlichen, worin die fertigungsspezifischen Vorteile modularer Mehrfachspannsysteme liegen, ist Ziel des Beitrags.

Modulare Mehrfachspannsysteme sind flexibel anwendbar

Für viele Zerspanungsarbeiten ist der klassische Maschinenschraubstock auch heute noch die passende Spannung. Mit den ständig neuen und erhöhten Anforderungen geht allerdings die Entwicklung der Spanntechnik in eine andere Richtung. Will man ein hohes Mass an Flexibilität und eine grosse Spanndichte erzielen und sollen gleichzeitig verschiedene Werkstücke auf kleinstem Raum gespannt werden, kommt der klassische Maschinenschraubstock oft an seine Grenzen. Häufig führt hier nur ein modulares Mehrfachspannsystem zum Erfolg. Spannsysteme müssen heute möglichst flexibel sein. Damit lassen sie sich an veränderte Umstände anpassen und können so die Wirtschaftlichkeit des Bearbeitungsprozesses erhalten. Modular ist ein Spannsystem, wenn es nach dem Baukastenprinzip aus Elementen zusammengesetzt und erweiterbar ist. Neben diesen grundsätzlichen Eigenschaften bedarf das Spannsystem jedoch weiterer prägnanter Merkmale: So muss es einfach und schnell zu handhaben sein, eine kompakte Bauweise mit hoher Spannkraft und Spanndichte verbinden und möglichst autarke Spannstellen aufweisen, deren Spanndruck einzeln zu verstellen ist. Im Idealfall kann mit nur einer Basisschiene ein breites Backenprogramm mit geringem Aufwand aufgebaut werden.

In der Serienfertigung besteht der wohl grösste Vorteil modularer Mehrfachspannsysteme darin, dass sich das System als rückbaubarer Vorrichtungsbaukasten für ein vielseitig gefächertes Werkstückspektrum einsetzen lässt. So spart sich der Anwender oft teilespezifische, teure Vorrichtungen. Mehrfachspannsysteme können zudem das Engineering vereinfachen, da sich auf vorhandenes Spannmateriale zurückgreifen lässt. So sind kurze Planungs- und Umrüstzeiten realistisch. Darüber hinaus trägt das modulare System zur erhöhten Prozesssicherheit bei und fördert die Qualitätstreue, die heute ein elementares, unabdingbares Kriterium der modernen Fertigung ist. Schliesslich ist ein Mehrfachspannsystem mit mehreren unabhängigen Spannstellen auch für den Einsatz in der Serie ideal, da so mehrere Werkstückspannungen mit unterschiedlichen Parametern möglich sind.

Anwendung ist bei horizontalem und vertikalem Aufbau möglich

Häufig wird bei der Serienfertigung eine Maschine mit horizontalem Aufbau, Palettenbahnhof und Spanntürmen verwendet. Was aber ist mit vertikalen Bearbeitungszentren? Wo liegen hier die Vorteile eines Mehrfachspannsystems? Spanntürme, die in der Serienfertigung mit modularen Mehrfachspannsystemen bestückt werden, weisen eine hohe Spanndichte auf, die zur verlängerten Spindelzeit führt. Gleichzeitig ist auch eine hervorragende Zugänglichkeit der Werkzeuge gewährleistet.

Vertikalmaschinen, deren komplette Tischflächen mit einem modularen Mehrfachspannsystem bestückt sind, ermöglichen Spanndichten, die denen auf Horizontalmaschinen gleichen

Mit einer vierten Achse kann eine Vertikalmaschine zur Serienmaschine mit Mehrseitenbearbeitung aufgerüstet werden, wobei auch hier eine hohe Spanndichte und Zugänglichkeit erreicht wird. Die horizontale und die vertikale Strategie lässt sich mit dem gleichen Spannsystem umsetzen, was bei Maschinenausfall mitunter eine echte Problemlösung darstellt.

Autarke Spannstellen sind auch für die Kleinserie wichtig

In der Einzelteil- und Kleinserienfertigung spielen modulare Mehrfachspannsysteme grundsätzlich die gleichen Vorteile wie in der Serienfertigung aus: hohe Spanndichte, geringere Werkzeugwechselzeiten, bessere Tischauslastung, gute Zugänglichkeit, einfache Handhabung, einfaches Engineering. Besonders wichtig ist hier jedoch die Flexibilität der Spanntechnik. Gerade bei kleinen Losgrößen geht viel Zeit beim Umrüsten verloren. Um diesen Vorgang zu optimieren, ist der Einsatz modularer Spannsysteme häufig das einzige Mittel. Daher ist die schnelle Verstellbarkeit der einzelnen Spannstellen in Spanndruck, Backenbreite oder Backenausführung unabdingbar.

Autarke Spannstellen sind gerade für den Einzelteilfertiger immens wichtig. Mit ihnen kann er sicherstellen, dass sich verschiedene Werkstücke aus unterschiedlichen Materialien gleichzeitig und prozessspezifisch spannen lassen (siehe Bild 2).

Der notwendige Spanndruck wird dabei ebenso gewährleistet wie die Verformungsfreiheit des Werkstücks. Letztlich resultiert aus der höheren Spanndichte eine längere Spindelzeit. Bei wiederkehrenden Kleinserien ist die reproduzierbare Spannsituation sehr wichtig. Wie in der Grossserie kann auch bei Kleinserien oder Einzelteilen die Tischfläche mit einem Mehrfachspannsystem besser ausgenutzt, der Werkzeugwechsel reduziert und die Wirtschaftlichkeit erhöht werden (siehe Bild 3).

Bei genauer Betrachtung der verschiedenen Fertigungsstrategien - Horizontal- oder Vertikal-BAZ sowie Serien-, Einzelteil- oder Kleinserienfertigung- wird die Vermischung der Verfahren deutlich. Die vermeintlichen Unterschiede sind oft nicht gross. Auch ist die Investition, die beim Übergang von einer Strategie zur anderen notwendig wird, jederzeit vertretbar und zu argumentieren. So erweist sich beispielsweise eine hochwertige Spannschiene mit drei oder vier Spannstellen als weitgehend preisneutral zu einem klassischen Maschinenschraubstock.

Für viele Anwendungen sind modulare Mehrfachspannsysteme ein echter Problemlöser und daher unumgänglich. Dies gilt sowohl für den Einsatz in der Serie als auch in der Einzelteilfertigung. Insofern haben beide Anwender - um zum Anfang zurückzukehren - mit ihrer Sichtweise recht. Nur gelten die Vorteile eben nicht nur für den jeweils anderen Bereich, sondern vor allem auch für den eigenen.

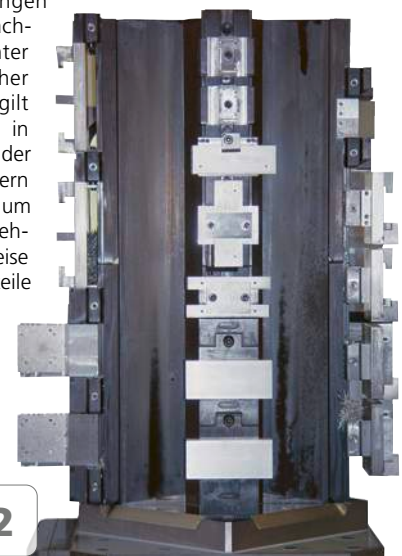

Kleinserienfertigung auf Horizontalmaschinen: Autarke Spannstellen ermöglichen die gleichzeitige, spezifische Fixierung unterschiedlicher Werkstücke.

Small batch production of different work pieces on a horizontal machining centre (family of parts)

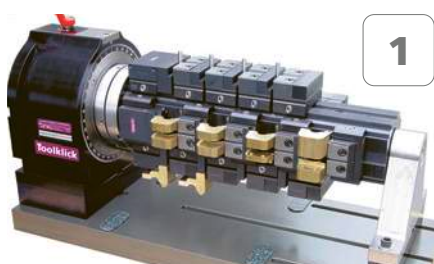

The dormant potential

From the press

Modular and multiple workholding systems are still underestimated in their economic potential. But they have proven their point in many practical applications in batch production, in some cases even on small series. This is due to their modular, compact design resulting in a very high workpiece density. In spite of their compact size, the clamping force is considerable. Producers of small batches see the advantages of these systems mainly in the quantity production, whereas the mass producer uses these modular vice elements on some occasions to quickly set up a fixture for only a few parts. The reason for this fact you will find in this editorial.

Modular workholding systems are very flexible in their use

For many machining applications the classical machine vice is still the suitable workholding solution. Since the introduction of the CNC machining centres the demand for flexible, modular systems has constantly increased. These systems allow the accommodation of many parts in a limited workspace. Also the number of tool changes are considerably reduced, which means less machining time per part and longer spindle time between the loading stops. Consequently the machine productivity goes up.

Modern multiple workholding systems must be flexible. The setting up of their modules must be simple and quick. The kit like components have to be adaptable to many different workholding configurations, just by placing them into other locations or changing jaws. Their clamping force must be adjustable to protect the workpiece. In the ideal case the base rail must be able to accommodate many different vice modules and jaws.

In the production of larger batches the modular workholding systems have the greatest advantages. Their interchangeable modules can be placed to suit the workpieces often replacing expensive dedicated fixtures. Engineering of fixtures may be simplified.

Hence planning and set up from one part to the next can be shortened. Multiple workholding systems contribute also to more constant and precise parts improving the interchangeability of products, an important criterion in today's industrial world. In some cases it is even possible to clamp a family of parts in one setup. Some of our customers take advantage of this feature.

Installation possible on horizontal and vertical machines

On horizontal machines tombstones (fixture carrying towers) are often installed on the pallets. This arrangement allows for machining on three faces even with very high workpiece density. What about machines with vertical spindles? Where are the advantages of multiple workholding

systems on such machines. The machine table can be filled with several workholding systems side by side allowing many parts to be clamped in a small area. If an indexer (fourth axis) is installed with a bridge or a trunnion exactly the same machining features are possible as on a horizontal

The output of a vertical machine with a fully loaded table surface is similar to that of a horizontal machine.

machines – lots of parts even when machining on three faces. If independent base rails are used they can be installed vertically as well as horizontally. A high interchangeability of components gives good flexibility in case of a machine break down.

Multiple workholding also for small batch production and families of parts

A very important advantage besides the points mentioned for large quantity production, is the workholding of part families, particularly if the parts are produced at intervals. In such cases the flexibility and the simplicity of set up is of great importance. For instance shaped jaws may be stored in the tool room ready for the next production run. In some applications users build dedicated fixtures and install Compact Clamp or microCLAMP vice modules on their own fixtures (see picture 2).

Naturally the rail based systems like the Power Clamp or the Compact Clamp can be used as a conventional vice if only one vice module and one end module is used. For wider workpieces sometimes two or more systems are installed side by side. Doing that, the vice modules and the reference surfaces are aligned by the serrations or the pins in the base rail.

Again, the clamping of different workpieces allows the use of the same tool on various cuts therefore giving longer machining cycles and less tool changes (see picture 3).

The investment in a multiple workholding system with three or four workholding stations is about the same as that for a conventional machine vice. But the multiple workholding system gives the user much greater flexibility and versatility.



Die Verwendung von Mehrfachspannsystemen auch in der Kleinserienfertigung reduziert den Werkzeugwechsel und erhöht die Wirtschaftlichkeit.

The use of a multiple workholding system is also beneficial in small batch machining.

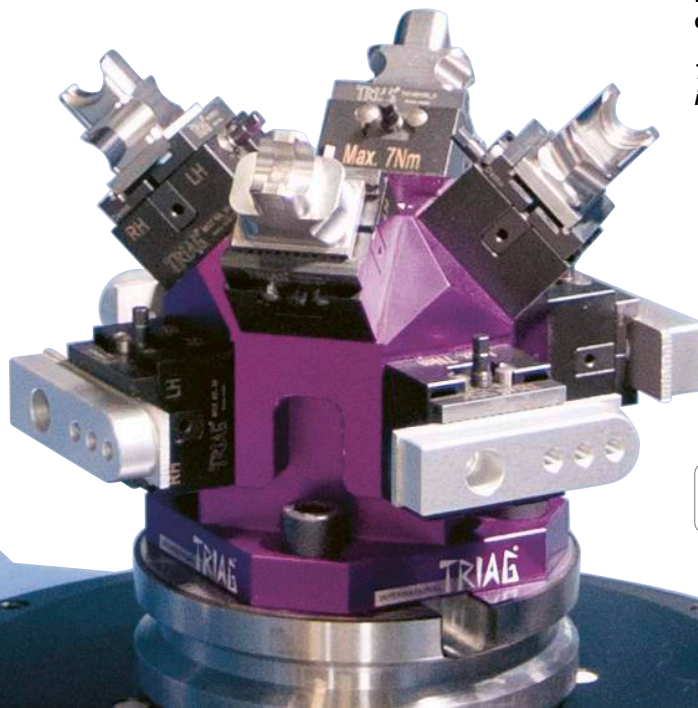

Mehrfachspannung auf spaceGRIP 1
Multiple workholding on spaceGRIP 1

Setzen Sie mit uns Potenziale frei!
Unlock the potential with us!



WIE? HOW?

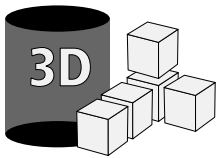

**3D-Modularität
für eine optimale
Raumnutzung**

*3D-Modularity for
an optimal use of
space*

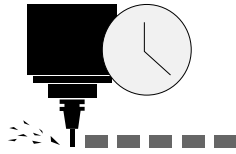

**Mehrfachspannung
für weniger
Maschinenstandzeit**

*Multiple workholding
for less machine down
time*

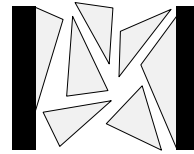

**Chaotisches Spannen für
das Erledigen von verschie-
denen Jobs gleichzeitig**

*Mixed clamping for the
manufacturing of different
jobs at the same time*

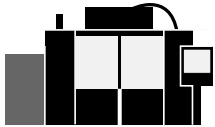

Grundvoraussetzung:
Zuverlässige Maschine mit
ausreichenden Werkzeug
und Paletten Plätzen und
eine geeignete Automati-
sierungsmethode









Basic requirement:
*Reliable machine with suf-
ficient tool an palett places
and a suitable automati-
sion method*



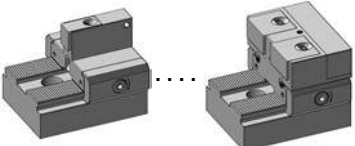
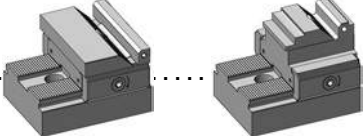

*power*CLAMP & *5axes*

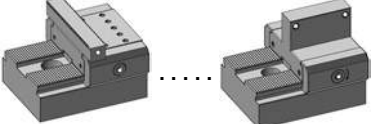

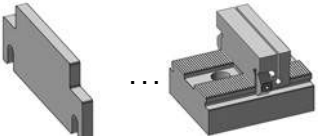
	Einleitung <i>Introduction</i>	15 - 21
	Bedienungsanleitung <i>Operating manual</i> Spannkraft und Drehmoment <i>Workholding force and torque</i>	22
	Anwendungsbeispiele <i>Examples of application</i>	23 - 38
	System - Basisschiene <i>System - base-rail</i>	 41 - 57
	Modular - Startersets <i>Modular - Starter kit</i>	 58 - 59
	Niederzugspannmodule <i>Pull down clamp modules</i>	 60 - 73
	Linearspannmodule mit Präge- und Linearbacken <i>Linear clamping modules with stamping and linear jaws</i>	 74 - 83
	Backen zu Linear <i>Jaws for linear</i>	 82 - 84
	Anschlagmodule <i>End module</i>	 85 - 92
	Verschiedene Module <i>Different modules</i>	 93 - 105
	Zubehör <i>Accessories</i>	 106 - 112

Warum modular Spannen Why modular workholding

powerCLAMP

Der klassische Maschinenschraubstock ist für gewisse Zerspanungsarbeiten vielfach die richtige Wahl, obwohl man einen Spannstock ohne Mehrkosten auch mit einem Modularsystem aufbauen kann. Er wird durch die ständig erhöhten Anforderungen an die Prozessoptimierung immer mehr durch modulare Spannsysteme ersetzt.

The classic machine vise is for some application still a good option, on the other hand can you set up the same with a modular clamp system at not higher costs! Because of always increasing demand and high competition you see more modular systems at endusers places, to keep up with productivity.

Mit den modularen Systemen wird ein hohes Mass an Flexibilität und grosser Spanndichte erreicht. Dies führt auch bei der Einzelteil- und Kleinserienfertigung zur Senkung der kostenintensiven Nebenzeiten, die einen wichtigen Faktor in der Wertschöpfungskette darstellen. Gegenüber Vorrichtungen ist der Vorteil, dass bei einem modularisiertem Aufbau die Aufspannung aus einem Baukastensystem (also standardisierten Einzelbauteilen) besteht, die kostengünstiger sind und für andere Aufspannungen wiederverwendet werden können. Zudem wird für die 3-Seitenbearbeitung eine gute Zugänglichkeit zum Werkstück gewährleistet.

With modular clamp system you achieve a high flexibility and also high density of holding workpieces. This brings you big advantages also by producing single parts or small quantities! Compared to dedicated fixtures you can use this vises for many different applications.

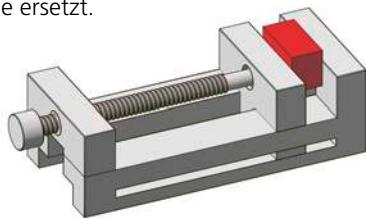

Spannen mit dem Spannstock
Clamping with the machine vise

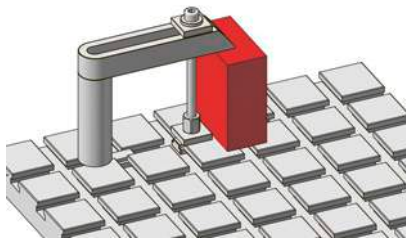

Spannen mit Spannpratzen
Clamps in operation

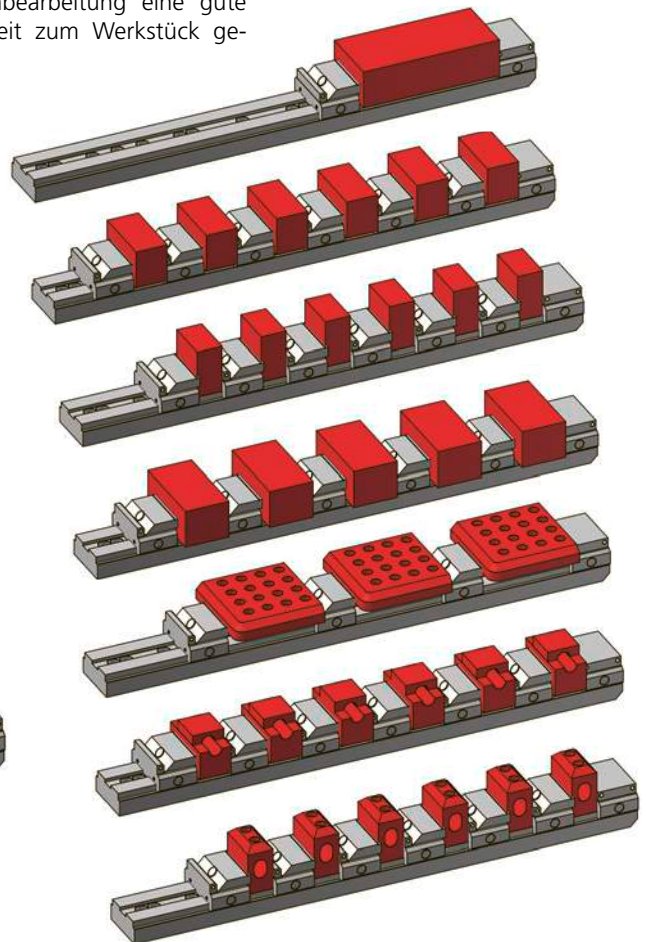
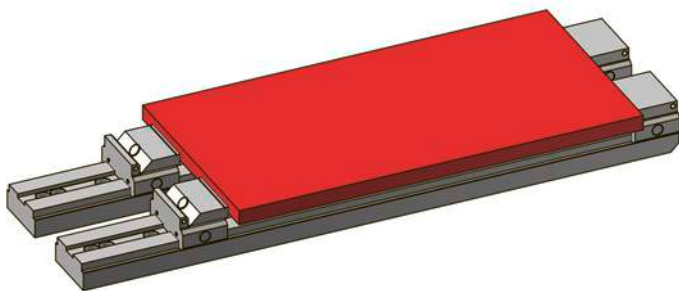

Ausserdem / And:

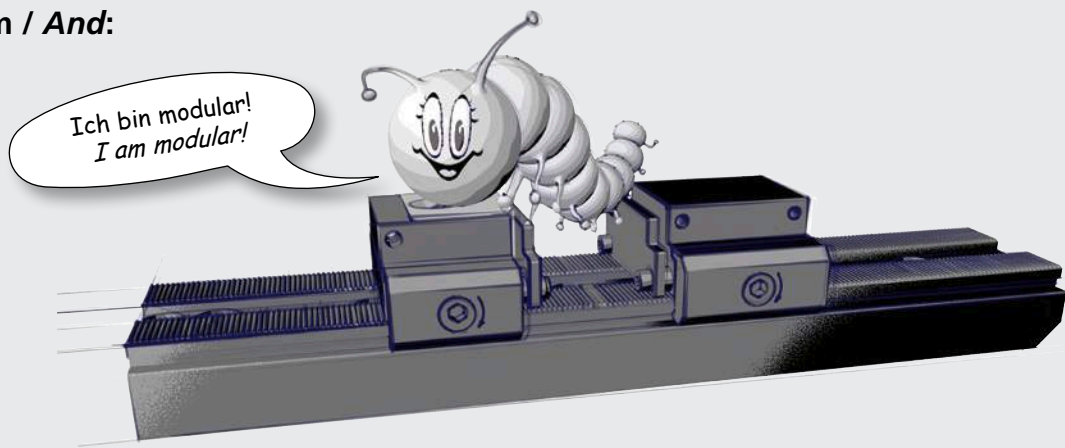

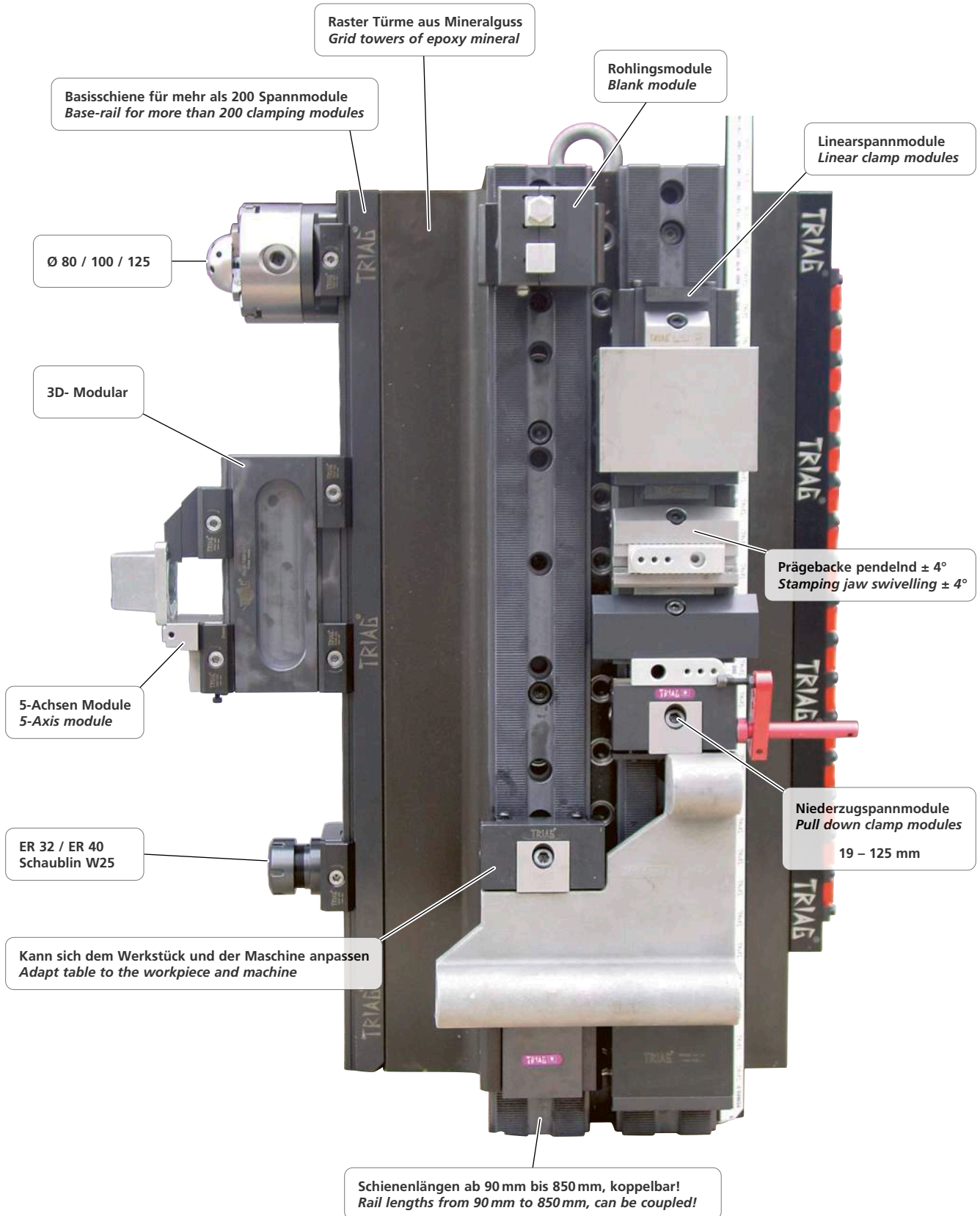

Modulares Spannen = Einzelspannung, Mehrfachspannung sowie auch das Spannen von kleinen, grossen oder unförmigen Werkstücken.
Chaotisches, gemischtes spannen!

Modular workholding = Single clamping, multiple clamping small parts and large workpieces can be clamped, also shaped parts are possible to clamp.
Mixed setups in chaotical clamp situation!

Mit dem Spannsystem Power Clamp hat die Triag International ein Produkt entwickelt, welches die Vorteile des klassischen Maschinenschraubstocks mit der Modularität eines innovativen Spannsystems in einer optimalen Art und Weise kombiniert und eine enorme Vielseitigkeit bietet. Einfache Spannungen sind genauso möglich wie Mehrfachspannungen und Spannungen von schwierigen Werkstücken.

With Power Clamp Triag has developed a product which includes the advantages of a classical vise and has the features of an advanced modular system. It can be used to clamp single parts (small and big) or multiple workholding as well as difficult to clamp parts.

Schnelligkeit / Quickness



1

Eine Schraube lösen
Loosen a screw



2

Abheben und neu platzieren
lift and change position



3

Eine Schraube anziehen
fasten one screw

Mit nur einer Schraubspindel, welche von beiden Seiten her zugänglich ist, werden die positionierten Module in einem patentierten Pratzensystem zuverlässig geklemmt.

Die Module können an jeder Stelle der Trägerschienen aufgesetzt werden. Verglichen mit dem üblichen axialen Aufschieben beschleunigt das den Aufbau von Mehrfachspannern und ermöglicht, diese Spannsysteme auch bei beengten Platzverhältnissen komfortabel zu rüsten.

With only one bolt screw (left and right hand thread) the clamp modules can be lifted and change position in 2mm steps.

This patented system is unique and fast, as well as accurate.



4

Drehmoment beachten
Observe the torque

Geringses Gewicht Low weight



= Einfaches Handling
= Easy handling

Das Modul kann mit zwei Fingern abgehoben werden.

The clamp module can be moved by two fingers.



Einfache Reinigung Easy cleaning



Keine spänefüllenden T-Nuten (im Gegensatz zu vielen Wettbewerbsprodukten) - Basis bilden stabile, mit Teilstücken verlängerbare Trägerschienen. Sie verfügen über eine hochgenau gefräste Verzahnung.

Eine Vielzahl an Spannmodulen mit unterschiedlichen Spannelementen lassen sich auf den Trägerschienen in einem Raster von 2 mm positionieren.

No chip catching T-slots (opposite of many competitors). The base rails are rigid and can be used modular in length width and height. The serration is accurate and checked for each base rail.

Many different clamp modules can be used on only one type base rail (step 2 mm)

Basisschienen / Base rails

Masssystem / Measurement system = metric & inch **powerCLAMP**

90 mm

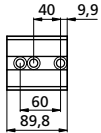

125 mm

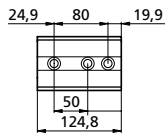

220 mm

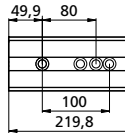

250 mm

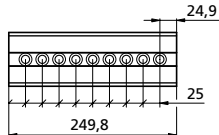

350 mm

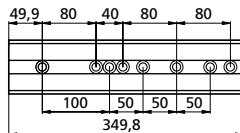

400 mm

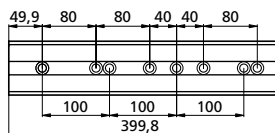

450 mm

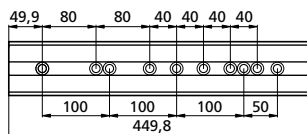

500 mm

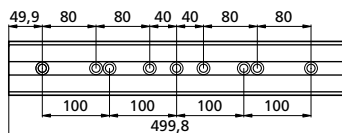

550 mm

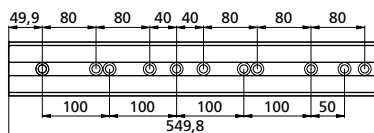

600 mm

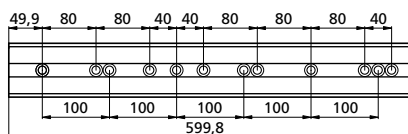

650 mm

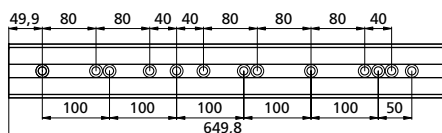

700 mm

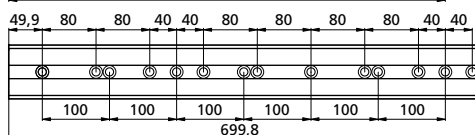

750 mm

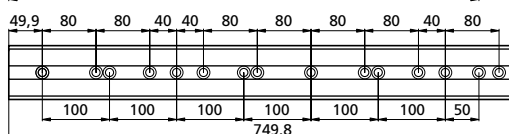

800 mm

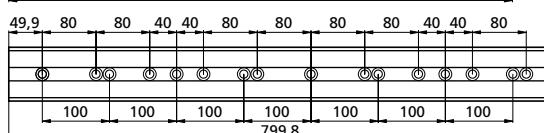

Schienen sind in den folgenden Höhen lieferbar:
Rails are in following ups available:

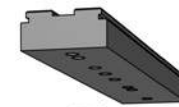

➔ 35 mm

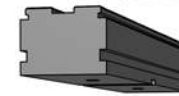

➔ 60 mm

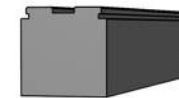

➔ 80 mm

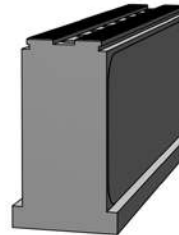

➔ 175 mm

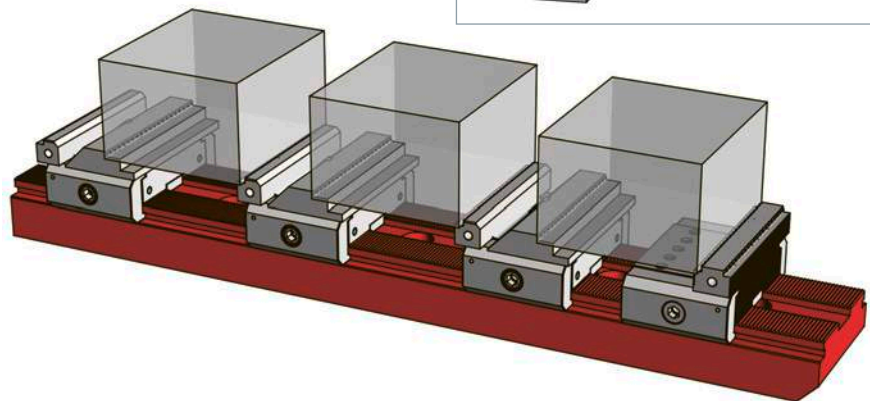

Basisschiene

Die Basisschiene ist das Grundelement des modularen Spannsystems von Triag International und ist in den Höhen 35 mm, 60 mm, 80 mm und 175 mm verfügbar. Auf der Basisschiene werden alle Spann- und Anschlagmodule über eine Schraubspindel mit einer Haltekraft von 15.000 daN (= 15 t) befestigt. Eine schnelle und genaue Positionierung ist durch die Verzahnung (2 mm Teilung) auf der Basisschiene gewährleistet und sorgt somit für kurze Rüstzeiten.

Durch den Einsatz von Erhöhungsmodulen wird die Werkstück-Zugänglichkeit speziell bei 5-Achsenmaschinen auch mit kurzen Werkzeugaufnahmen ermöglicht. Somit ist die Maximalgröße der Werkstücke nur noch durch die Maschinengröße eingeschränkt. Die Basisschiene dient in diesem Zusammenhang als mechanisches Nullpunktsystem.

Die Basisschienen sind für eine schnelle Aufspannung auf den gängigsten Palettsystemen konzipiert. Aus Gewichtsgründen können auch die eigens entwickelten Spanntürme aus Mineralguss eingesetzt werden. Diese verfügen über eine so hohe Vibrationsdämpfung, dass dadurch im oberen Bereich der Türme sehr präzise gearbeitet und dabei eine exzellente Oberflächengüte erreicht werden kann.

Basisschienen / Base rails

Masssystem / Measurement system = metric & inch powerCLAMP

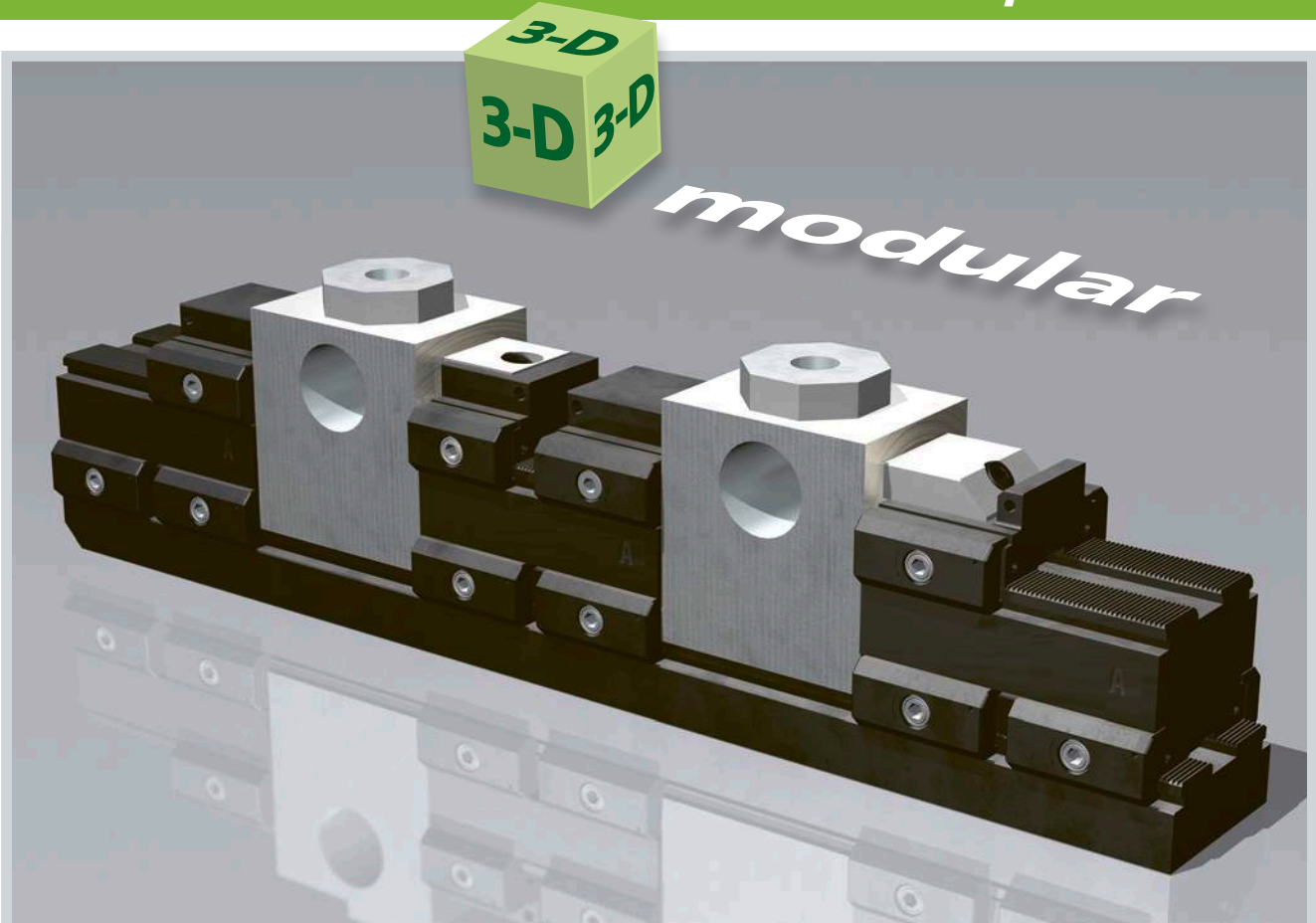

Mit verschiedenen Basismodulen kann man auch die 3. Dimension Modular gestalten! Mit der Höhe von 60 mm kann die Modulhöhe auf 94 respektive auf 109 mm erhöht werden (34/49 Modulhöhe). Die Länge von 130 mm erlaubt es jeweils ein Spannmodul und ein Anschlagmodul zu platzieren.

There are different sizes of riser blocks to increase the height of the clamp modules. This way you can get from 34 to a clamp height of 94 or 109 mm depending on the clamp module you choose. This riser blocks makes the power clamp system 3D-modular!

Mehr auf Seite | More on Page 48

Base rail

The base rail is the basic element of the Triag modular clamp system. We offer them in different lengths and heights and more than a hundred different standard clamp modules will fit onto the base rails.

Holding force which the clamp modules are clamped to the base rail is 15'000 daN (15t). The precision serration in 2mm pitch allows to fit the clamps fast and accurate.

All three dimension are modular! You can double or triple the length with coupling the rails or you can use them side words in a row. Also the height is modular (please see next page)

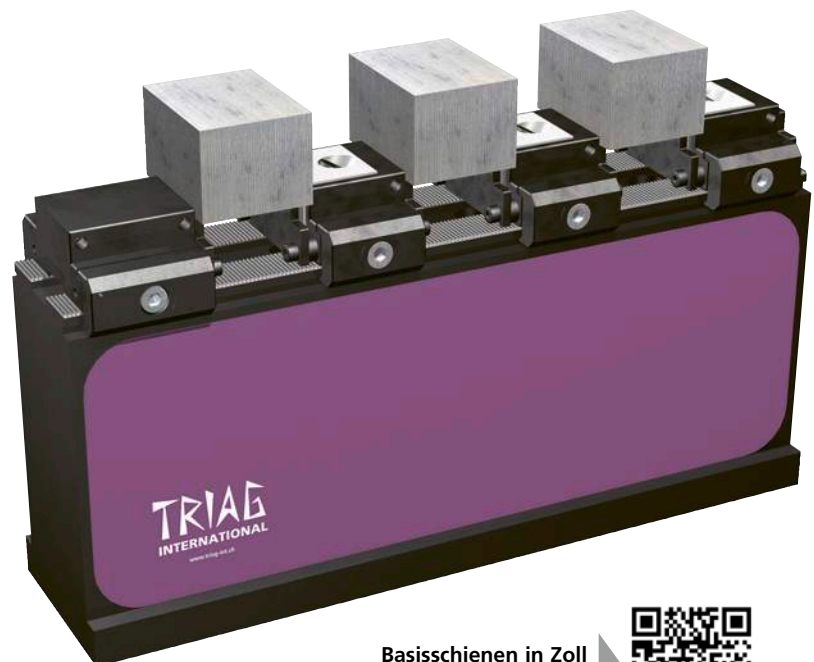

Basisschienen in Zoll
Base rails in inch



Das Anschlagmodul / End modules

Für das Spannsystem «Power Clamp» ist in der Regel nur ein Anschlagmodul als «feste Backe» notwendig. Mittels der 2 mm Verzahnung lässt sich das Modul sehr genau auf der Basisschiene positionieren und ist mit der Schraubspindel schnell befestigt.

Für die unterschiedlichen Bearbeitungssituationen steht eine Vielzahl von Ausführungen zur Verfügung. Diese unterscheiden sich in der Breite der Backen (ab 19 mm bis max. 150 mm) als auch in der Beschaffenheit der Spannflächen (glatt, geriffelt, gerillt, hartmetallbeschichtet oder mit Prägeverzahnung, mit der direkt geprägt werden kann).

In a row of parts there is usually one end module followed by the clamp modules. For all the different clamp situation we offer a wide range of different end modules from 19 mm to 150 mm.

Usually you have one side of the datum face flat and the opposite double serrated so you have two options in one. Also direct stamping end modules with a workholding step of 3 mm are available.

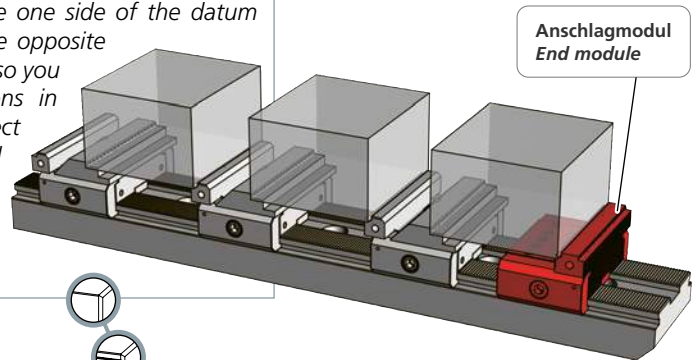

Anschlagmodul
End module

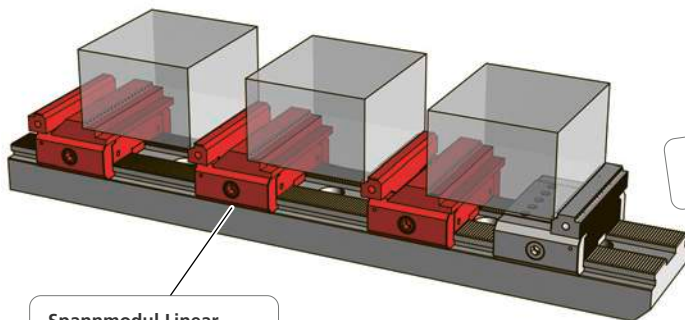

Spannmodul Linear
Linear clamping module

Verschiedene Ausführungen der Anschlagflächen!
Different styles at grip surfaces!



Lineare Direktprägespannung
Linear direct stamping module

Das Spannmodul / Clamp modules

Die «beweglichen Backen» gibt es in zwei Ausführungen. Zum einen für das Niederzugspannsystem und zum anderen für das Linearspannsystem. Dabei dient das Spannmodul bei beiden Systemen wiederum als Anschlagmodul für die nächste Aufspannung.

Die Breite der Spannfläche bewegt sich wie bei den Anschlagmodulen im Bereich zwischen 19 mm und 125 mm. Durch die innovativen Ausführungen der Spannflächen wie z. B. die Prägebacken oder Druckstifte werden enorme Haltekräfte erreicht.

Bei umfangreichen Testreihen zu der Werkstückverschiebung bei einer Spannkraft von 2000 daN und einer Zerspankraft von bis zu 600 daN wurden bei der Verwendung von Prägebacken nur minimale Abweichungen vom Nullpunkt festgestellt. Leichte Abweichungen von der Parallelität der Werkstücke werden mit der Pendelfunktion ($\pm 4^\circ$) ausgeglichen.

Innovative Lösungen gibt es auch für spezielle Spannaufgaben, wie z.B. Formbacken, Dreibacken- und Spannanzgenfutter, Vakuumplatten oder Magnetspannplatten.

There are mainly two different types of clamp modules. Linear and pull down jaws both with integrated datum face for the next workpiece. Datum face can normally be double serrated or flat.

The movable jaws you can get in various versions such as hardened flat, carbide coated soft jaws double serrated, linear pull down, direct stamping dovating and more. The width of the clamps modules starts from 19 mm up to 125 mm.

Clamping force goes to a maximum of 2800 daN (2,8t).

For special clamping situations we offer also chucks, collet chucks vacuum plates or even magnet plates which fits onto the Power Clamp base rails.

**Niederzugspannmodule
Pull down clamp modules**

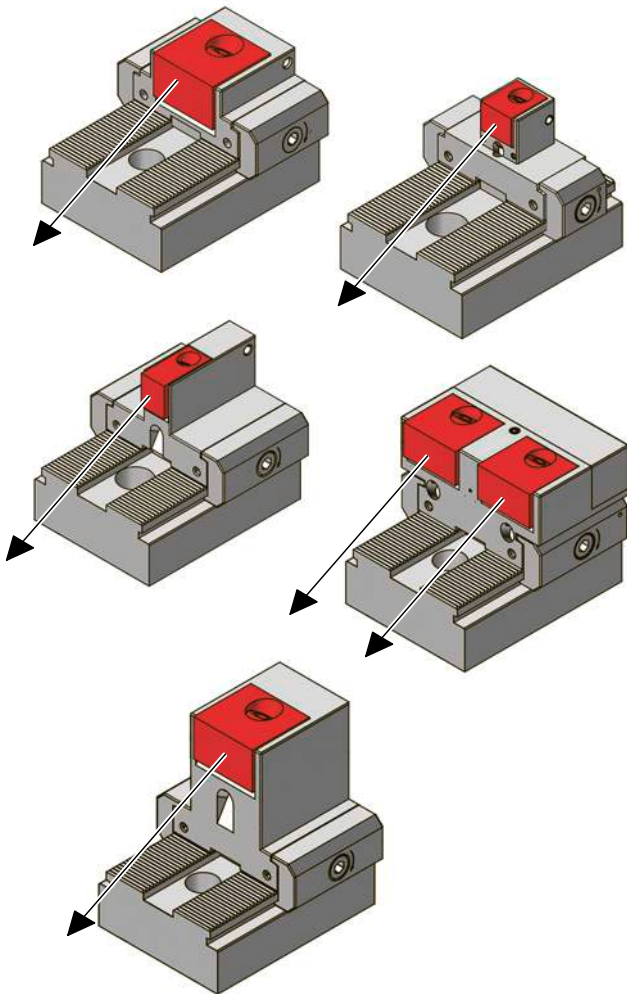

Die Fakten beim Niederzugspannsystem

Verstellbereich: 0- 4,1 mm
Spannkraft: Bis 2'800 daN

Vorteile beim Niederzugspannsystem:

- Höhere Haltekräfte
- Hohe Wiederholgenauigkeit
- Optimale Spannmethode für Kleinteile
- Mit Schnellwechselbacken
- Doppelspannsystem in einer Backe zum Spannen und Bearbeiten von zwei Kleinteilen
- Mit Vorsatz als Linearspannsystem einsetzbar
- Auch Anschläge mit Niederzugeffekt erhältlich

Facts for pull down clamp modules

Jaw range: 0- 4,1 mm
Clamping force: up to 2'800 daN

Advantages pull down jaws:

- Higher holding force
- With linear adaptable jaws
- Also with pull down jaws for the stop side available
- With adapter set can be changed to linear
- Also pull down jaws for datum face

**Linearspannmodule
Linear clamp modules**

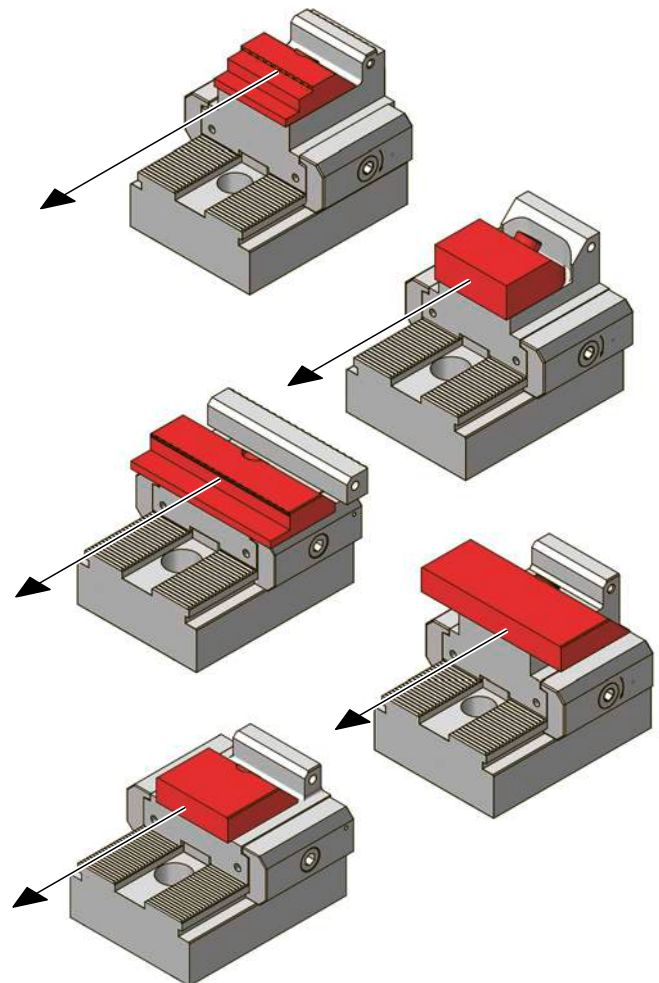

Die Fakten beim Linearspannsystem

Verstellbereich: 0- 5,0 mm
Spannkraft: Bis 1'600 daN

Vorteile beim Linearspannsystem:

- Spannstockähnliches Spannen
- Prozesssichere Positionierung der zweiten Aufspannung
- Gut geeignet für die Erstellung von individuellen Formbacken
- Sicherer Halt mit Prägetechnik

Facts for linear clamp modules

Jaw range: 0- 5,0 mm
Clamping force: up to 1'600 daN

Advantages linear jaws:

- Similar clamp as conventional vise
- Good for shaped jaws
- Secure clamped with direct stamping jaws
- Higher accuracy

ACHTUNG / CAUTION

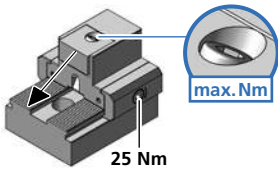

Niederzug Spannmodule
Pull adown module

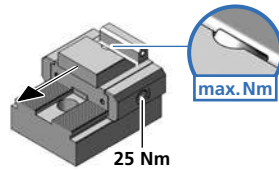

Linear Spannmodule
Linear module



Schraube / Screw	Drehmoment / Torque		Spannkraft / Workholding force			
	Nm	(lb-ft)	~daN	~(lb)	~t	
M5 + M6	4	3	= 500	1100	0,50	
	5	3,7	= 580	1280	0,58	
	6	4,4	= 690	1520	0,69	
	7	5,2	= 780	1720	0,78	
	8	5,9	= 880	1940	0,88	
	9	6,6	= 980	2160	0,98	
	10	7,4	= 1020	2250	1,02	
	12	8,9	= 1220	2690	1,22	
	M6	14	10,4	= 1450	3200	1,45
		15	11	= 1520	3350	1,52
4		3	= 410	900	0,41	
M8	5	3,7	= 490	1080	0,49	
	6	4,4	= 560	1230	0,56	
	7	5,2	= 660	1450	0,66	
	8	5,9	= 730	1600	0,73	
	9	6,6	= 810	1790	0,81	
	10	7,4	= 900	1980	0,90	
	15	11	= 1520	3350	1,52	
	20	14,8	= 1810	3990	1,81	
	25	18,4	= 2100	4630	2,10	
	M10	10	7,4	= 400	880	0,40
20		14,8	= 1400	3090	1,40	
30		22,1	= 2000	4410	2,00	
40		29,5	= 2800	6170	2,80	

Schraube / Screw	Drehmoment / Torque		Spannkraft / Workholding force		
	Nm	(lb-ft)	~daN	~(lb)	~t
M8	10	7,4	= 400	880	0,4
	20	14,8	= 800	1760	0,8
	30	22,2	= 1200	2650	1,2
	40	29,6	= 1600	3530	1,6

WICHTIG: Die angegebenen Drehmomente sind die absoluten Maximalwerte. Über die Spannkraften geben die Tabellen Auskunft.

IMPORTANT: The torque numbers specified represent the absolute maximum. The table at the bottom of this page provides further information on the workholding forces.



1 TWPAS1240 (60 Nm)
M12x40 (100 Nm)

2 ±0,3

3 2x

4

5 ~ 1-3 Nm

6

Drehmoment / Torque
siehe Tabelle / see chart

7 **WICHTIG:** Vor dem Positionieren der Spannmodule für ein neues Werkstück, ist die **Spannbacke ganz zurück zu stellen**, dies gewährleistet eine sichere Spannung!

IMPORTANT: Prior to setting up a new clamping module the **clamping jaw of the vice module must be retracted all the way!** This guarantees proper clamping of the new workpiece.

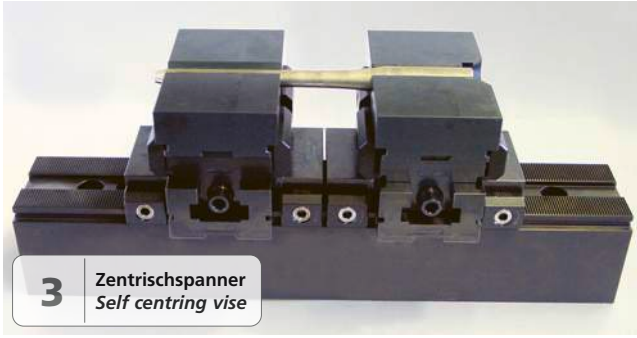
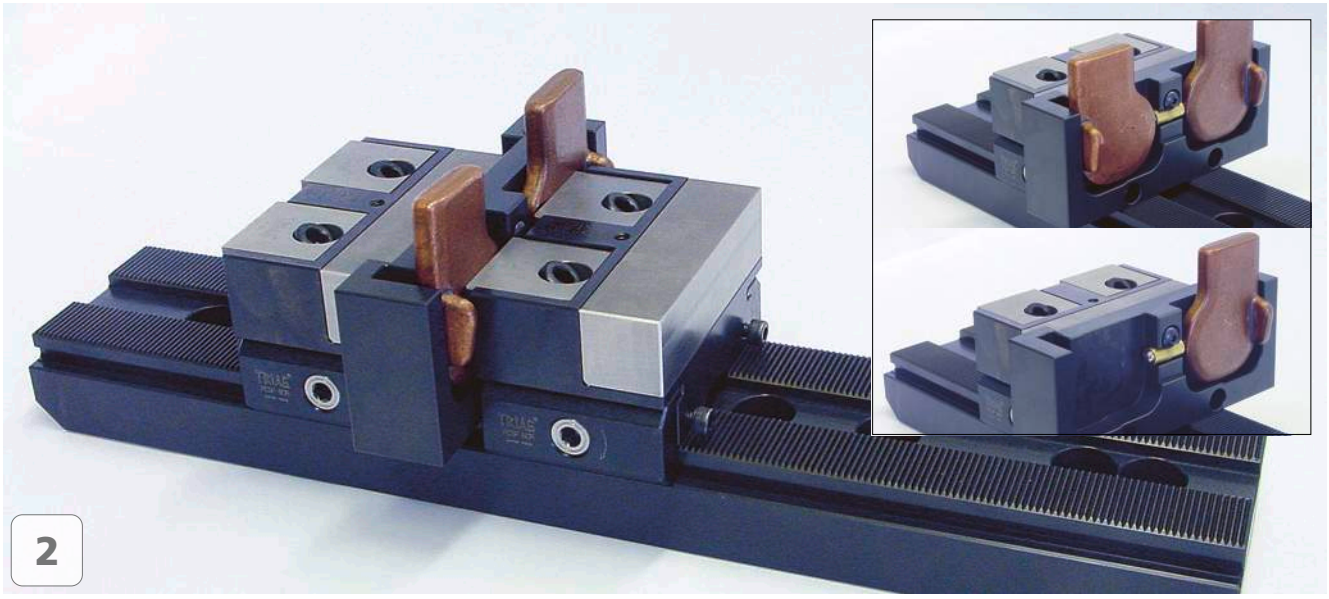
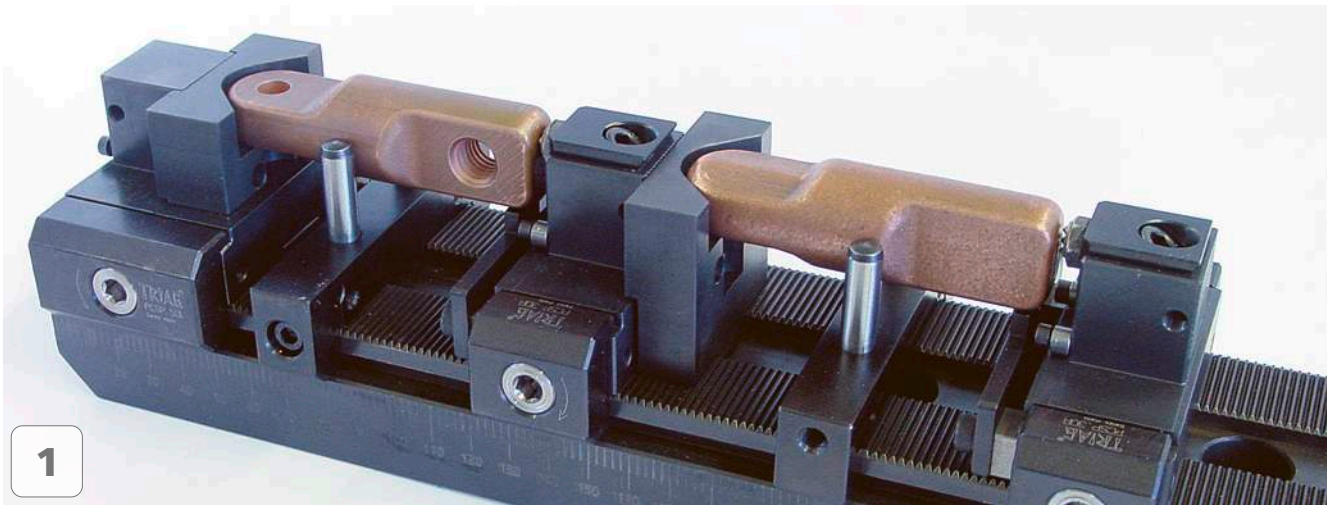

Zentrischspanner
Self centring vise

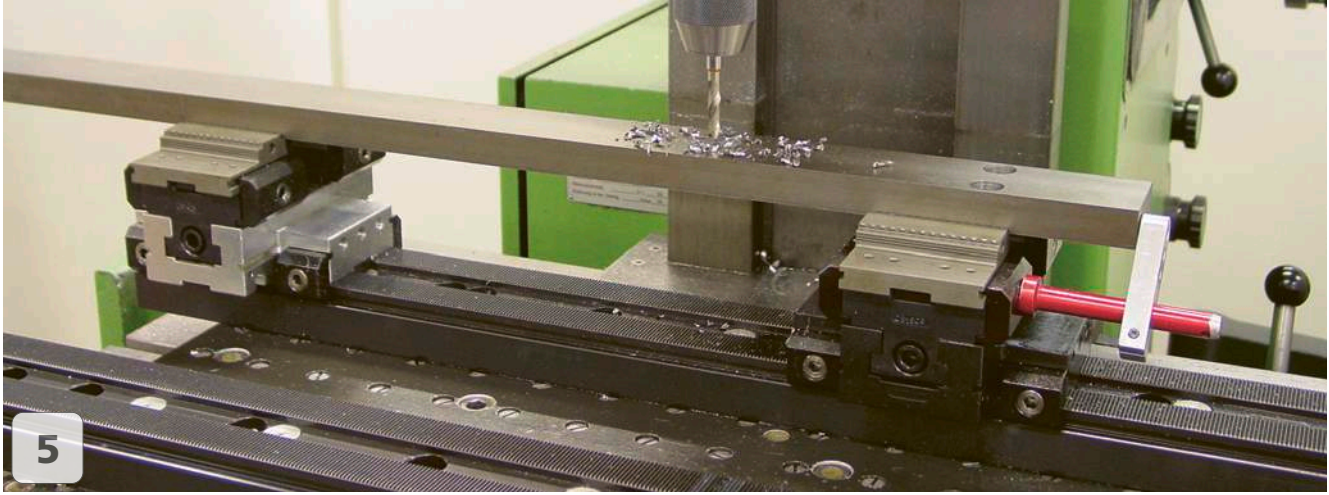
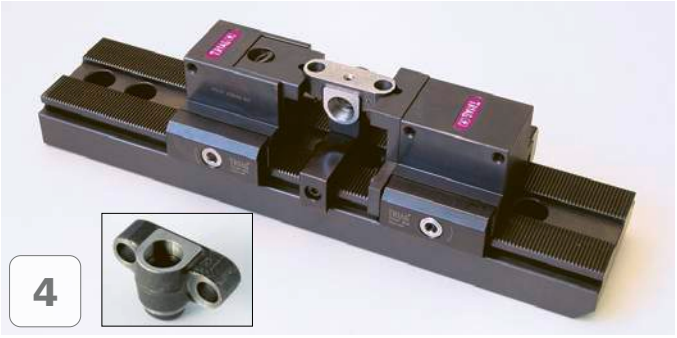

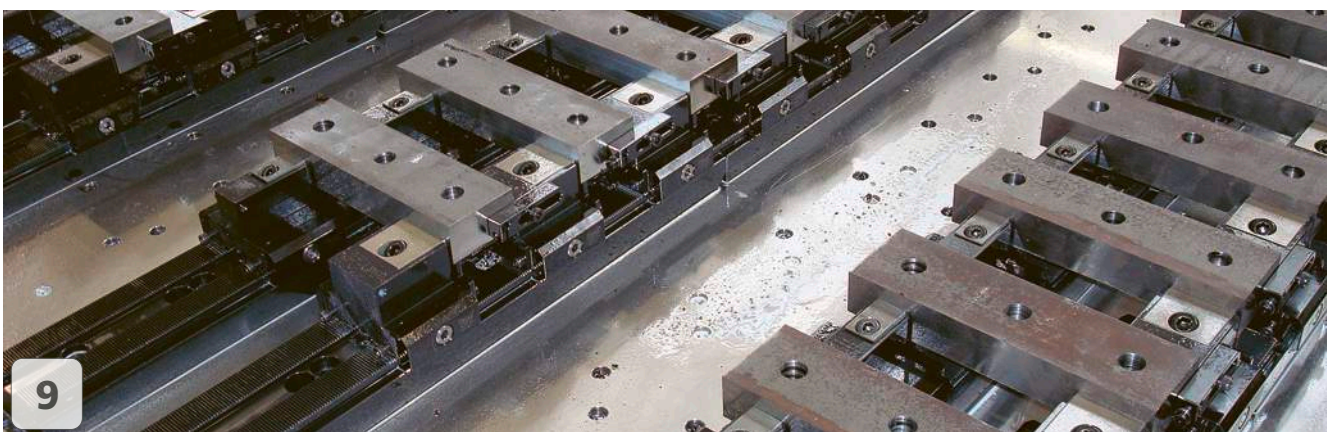
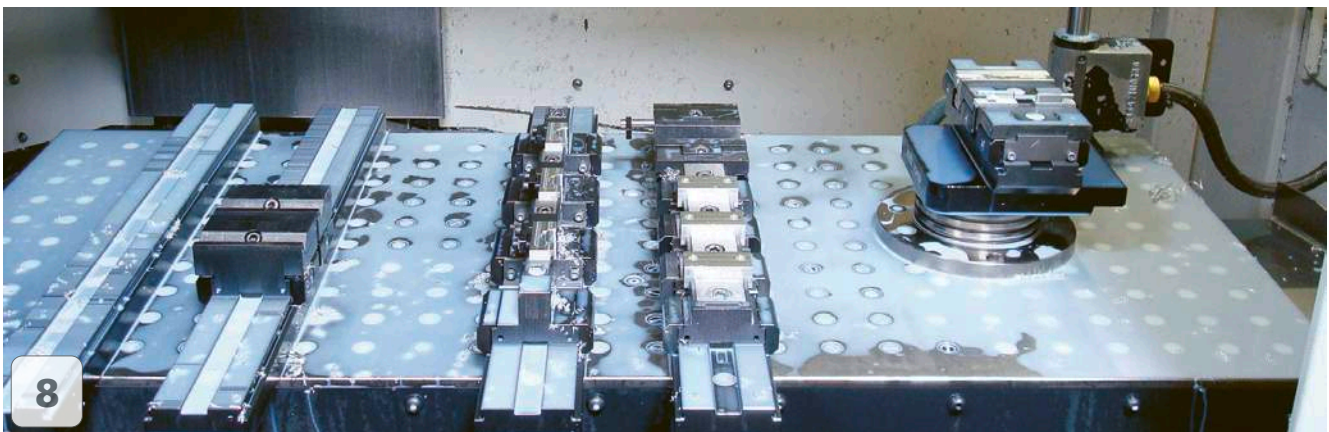
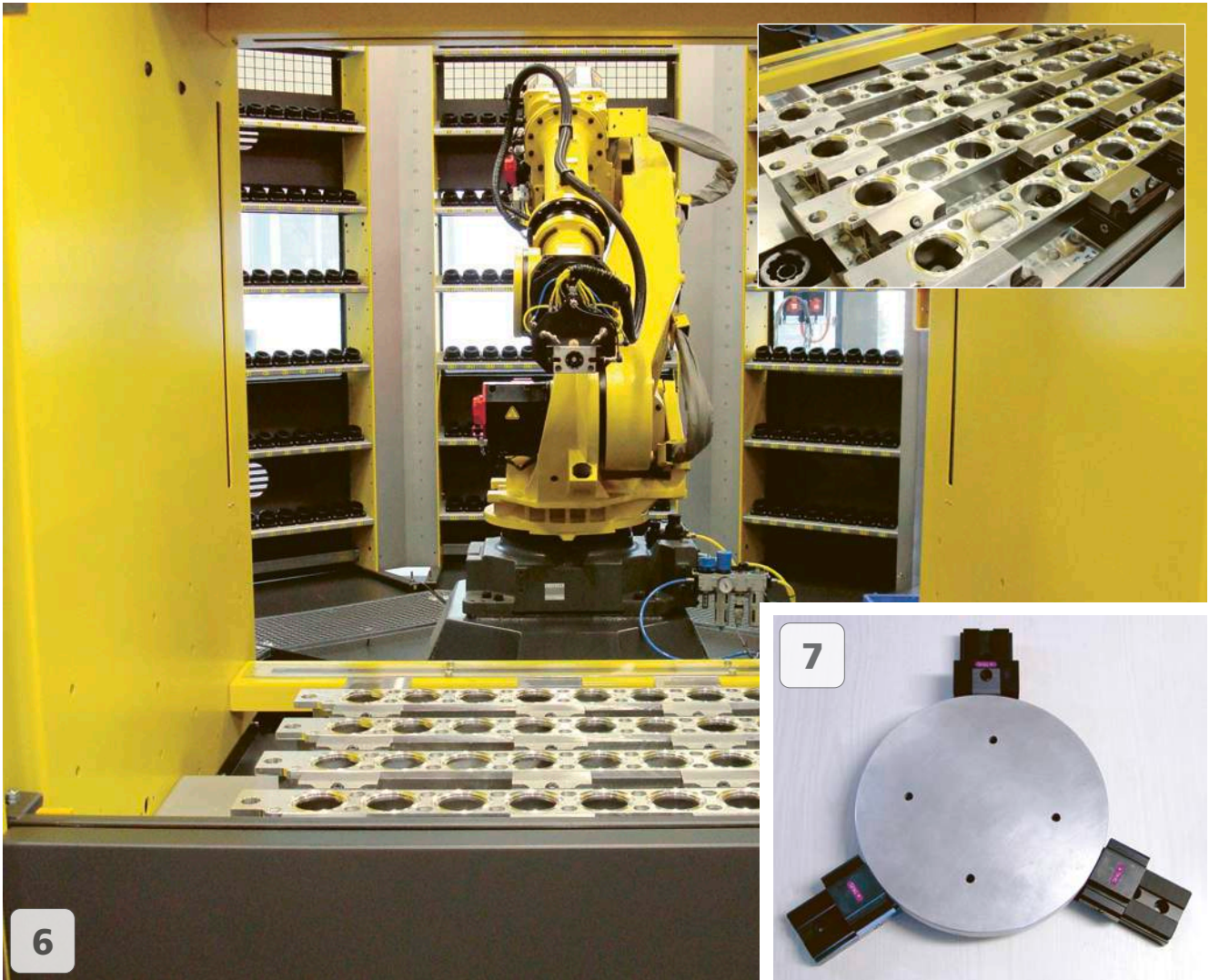

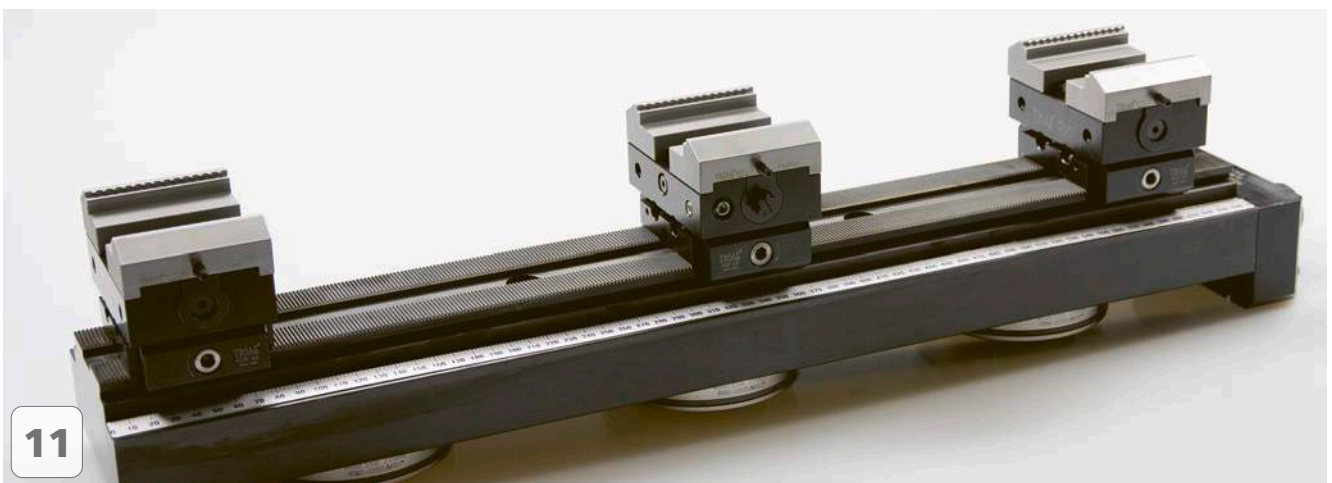
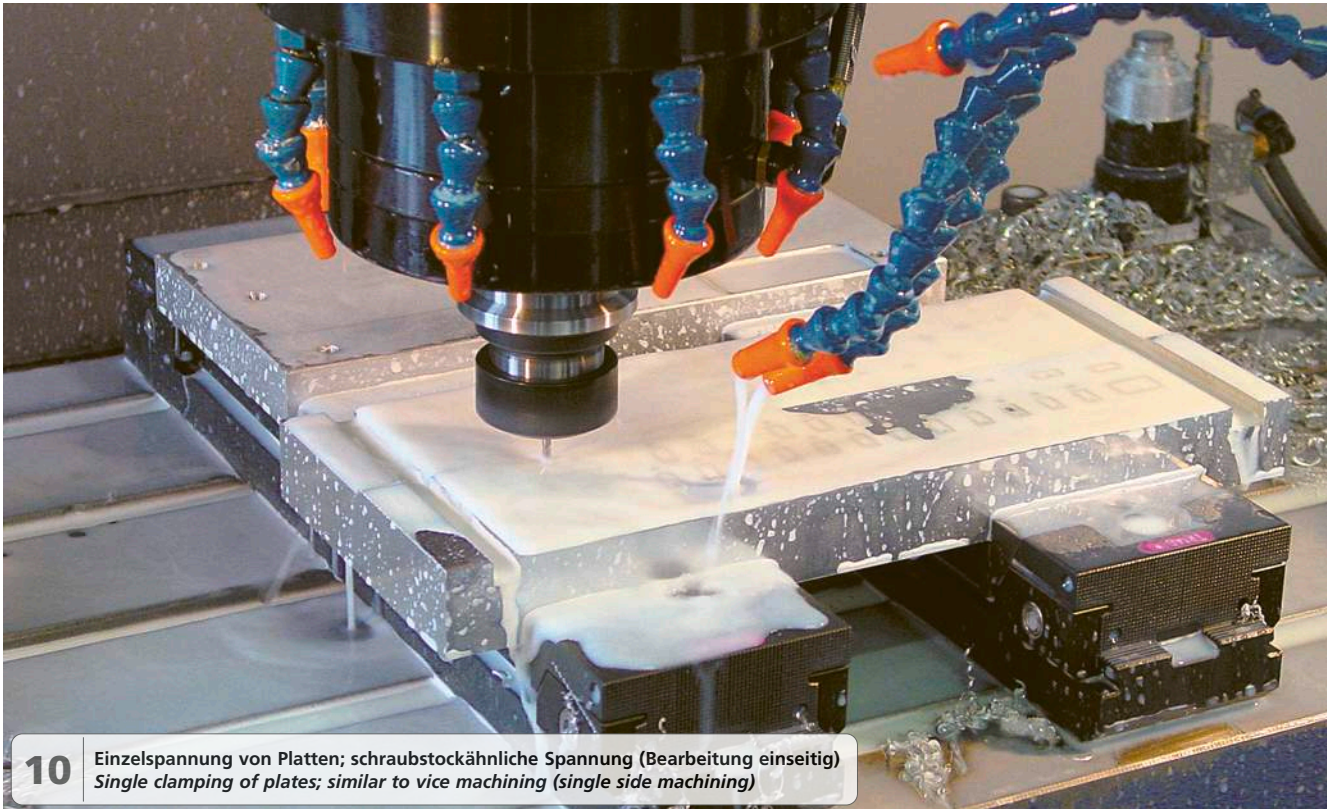

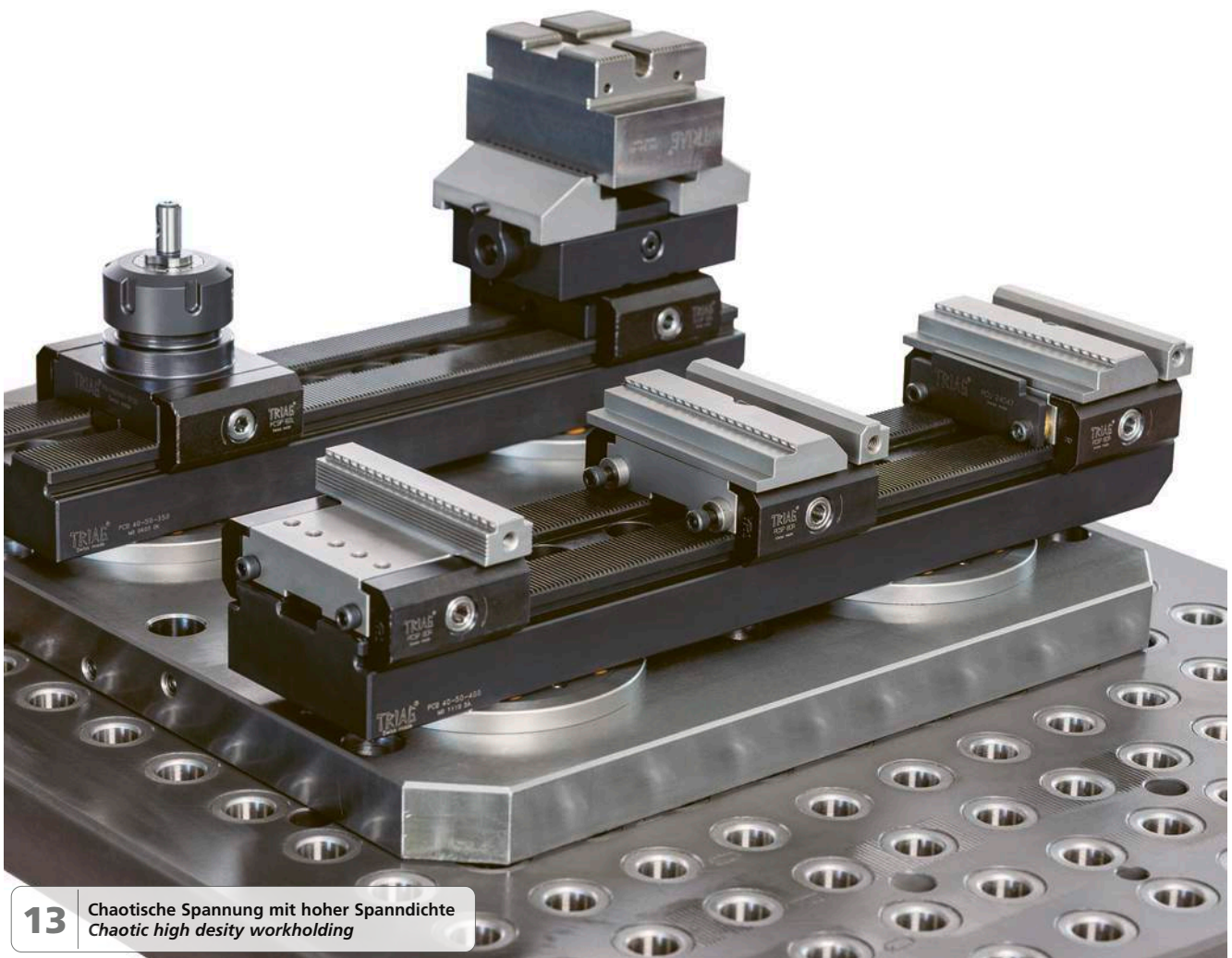

13 Chaotische Spannung mit hoher Spanndichte
Chaotic high density workholding

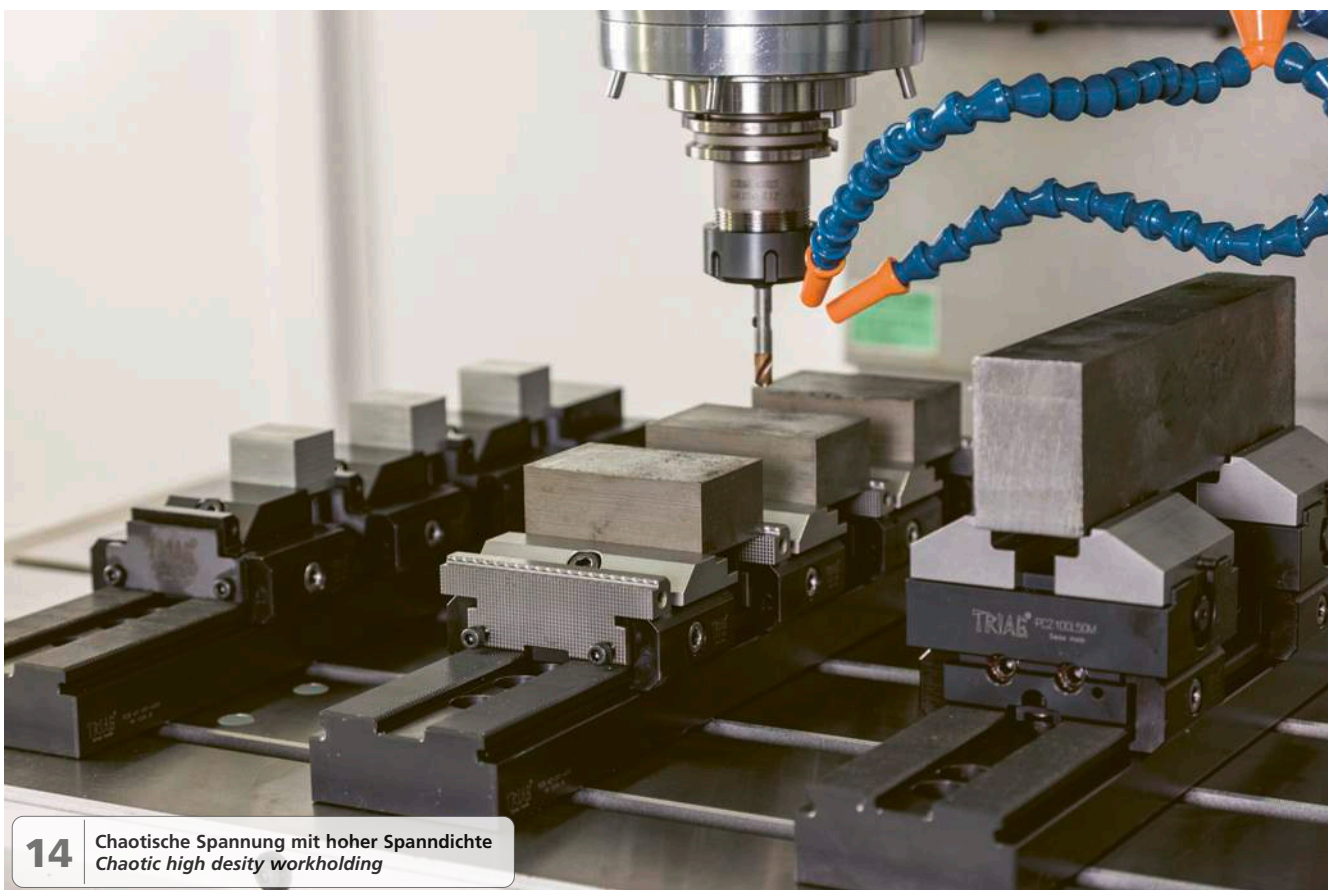

14 Chaotische Spannung mit hoher Spanndichte
Chaotic high density workholding

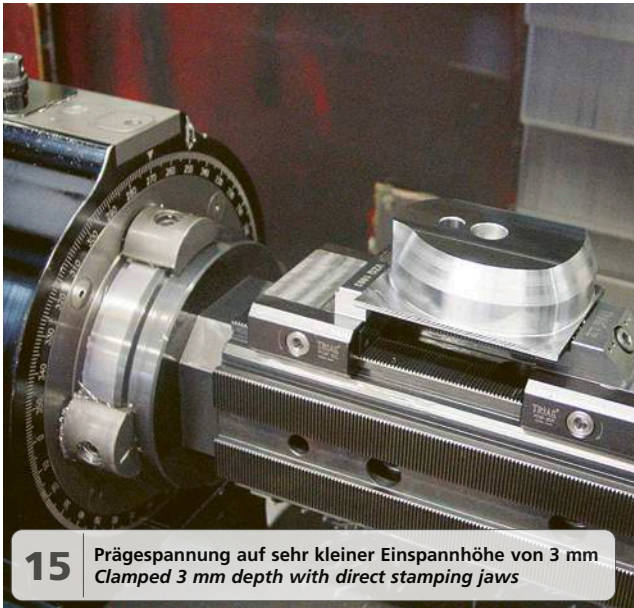

15 Prägespannung auf sehr kleiner Einspannhöhe von 3 mm
Clamped 3 mm depth with direct stamping jaws

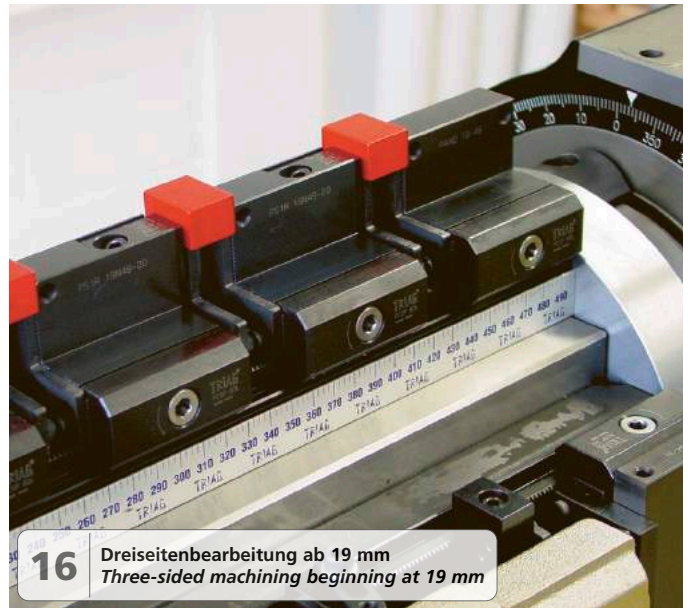

16 Dreiseitenbearbeitung ab 19 mm
Three-sided machining beginning at 19 mm



17 ... im Einsatz auf der 4. Achse
... in action on the 4th axis



18 Das Triag Power Clamp im Einsatz als Spannstock (Starterset)
Triag Power Clamp in action as machine vise (starter set)

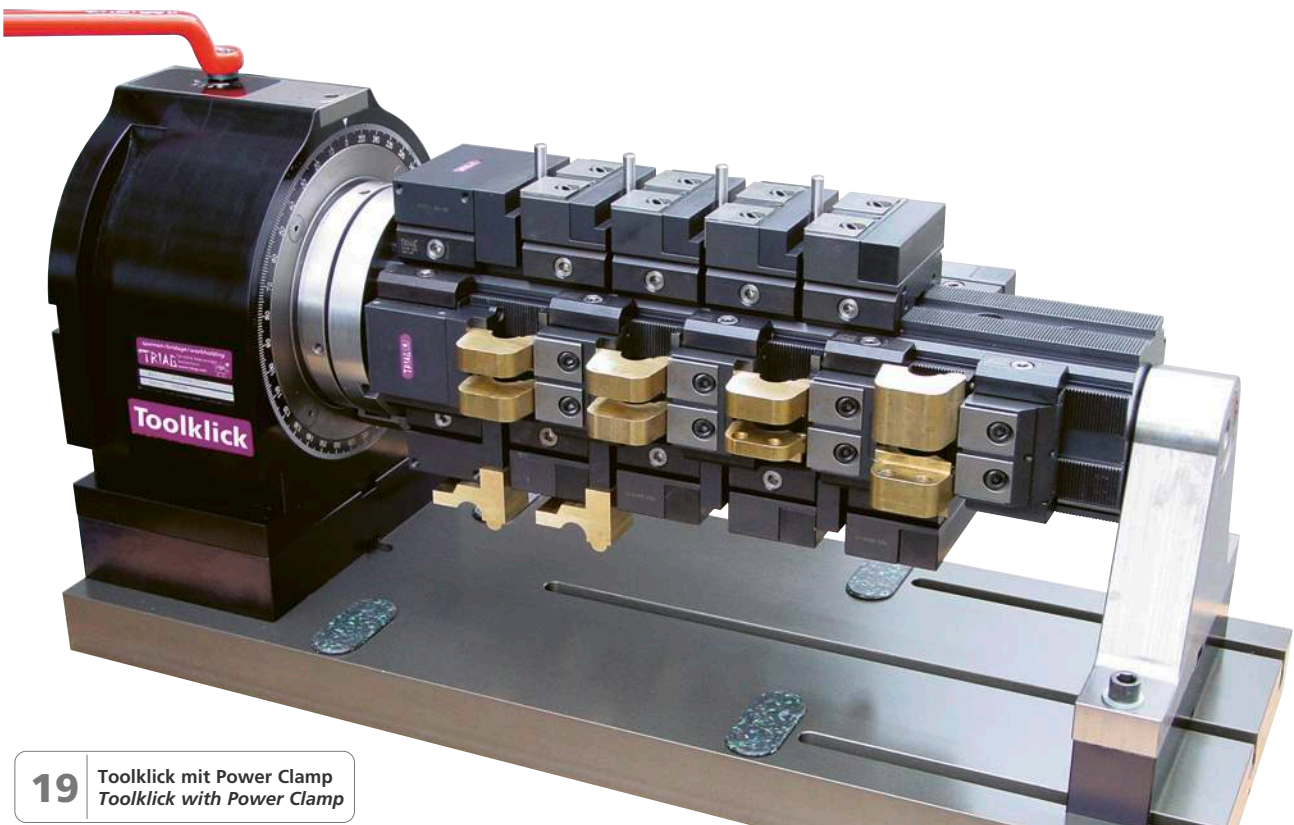

19 Toolclick mit Power Clamp
Toolclick with Power Clamp

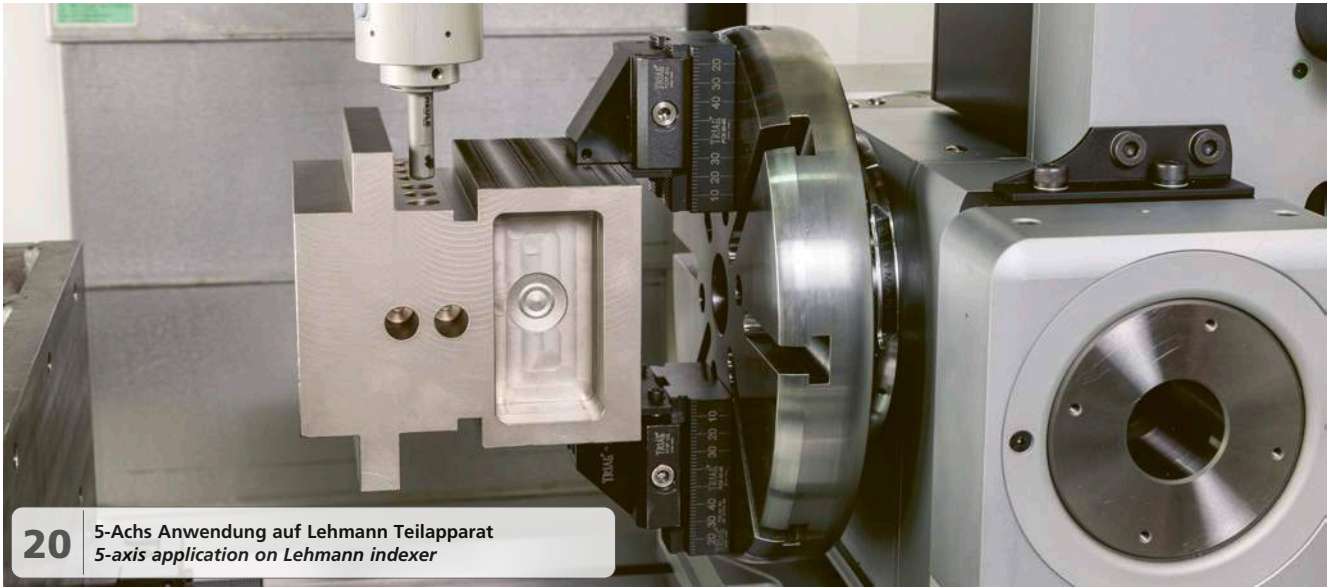

20 5-Achs Anwendung auf Lehmann Teilapparat
5-axis application on Lehmann indexer



21

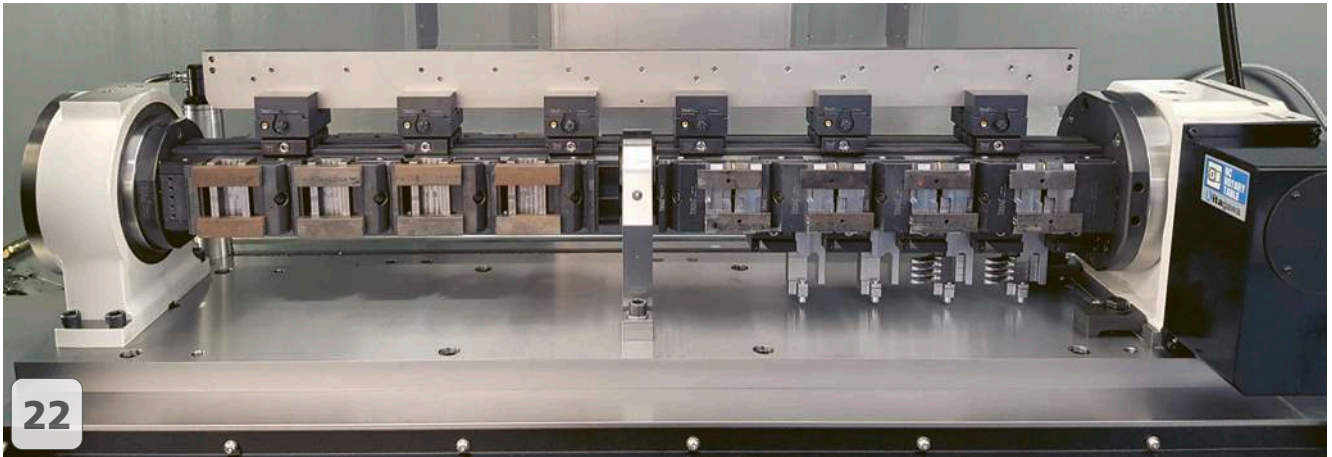

22

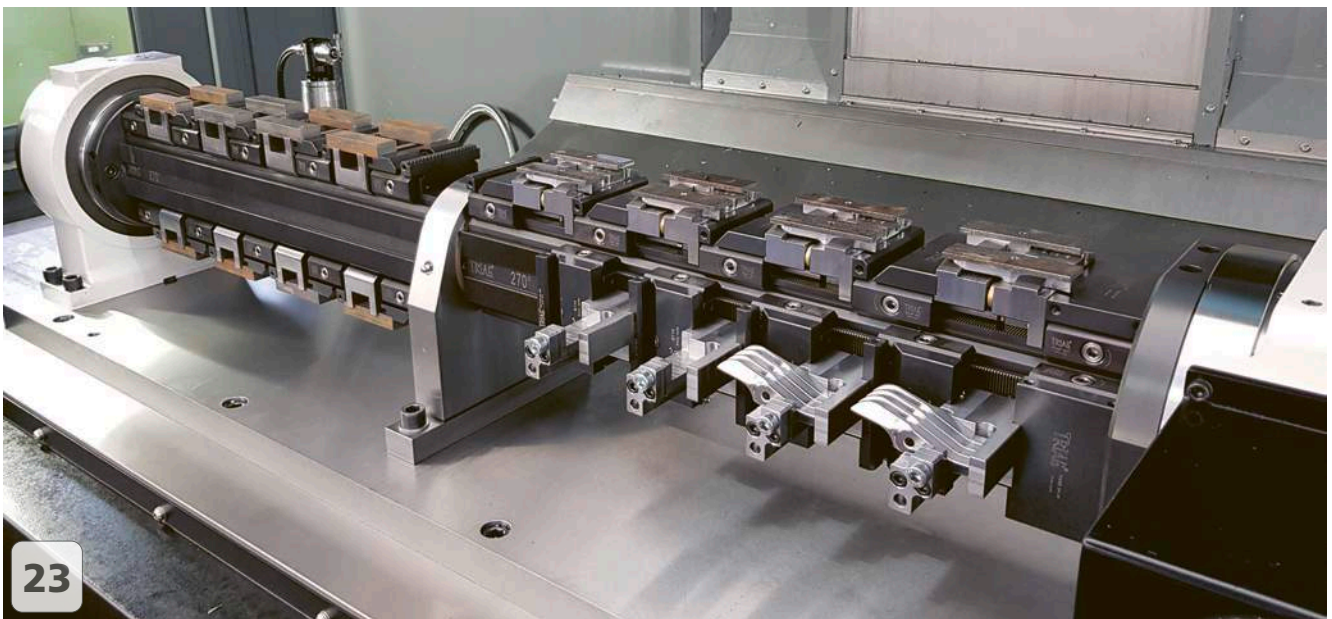

23

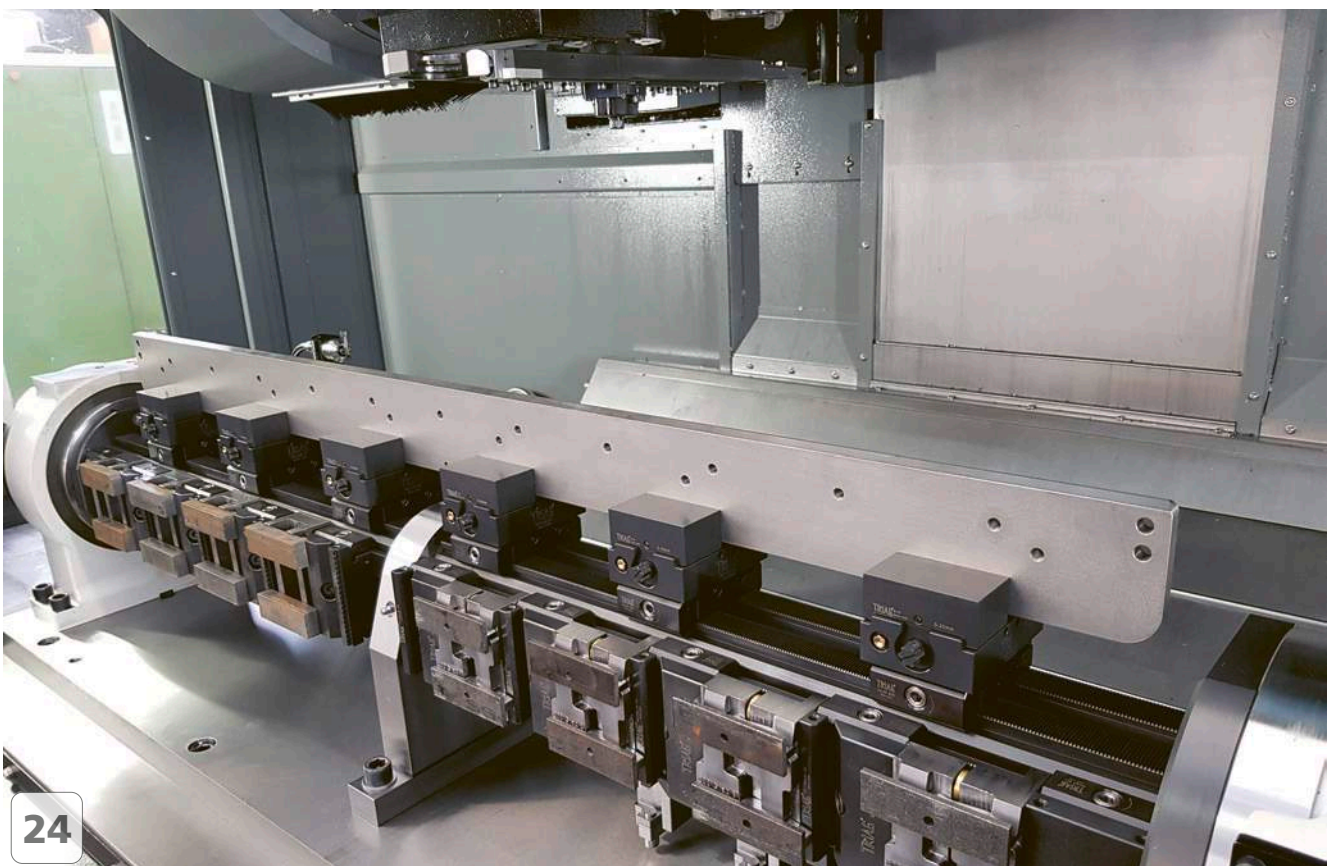

24

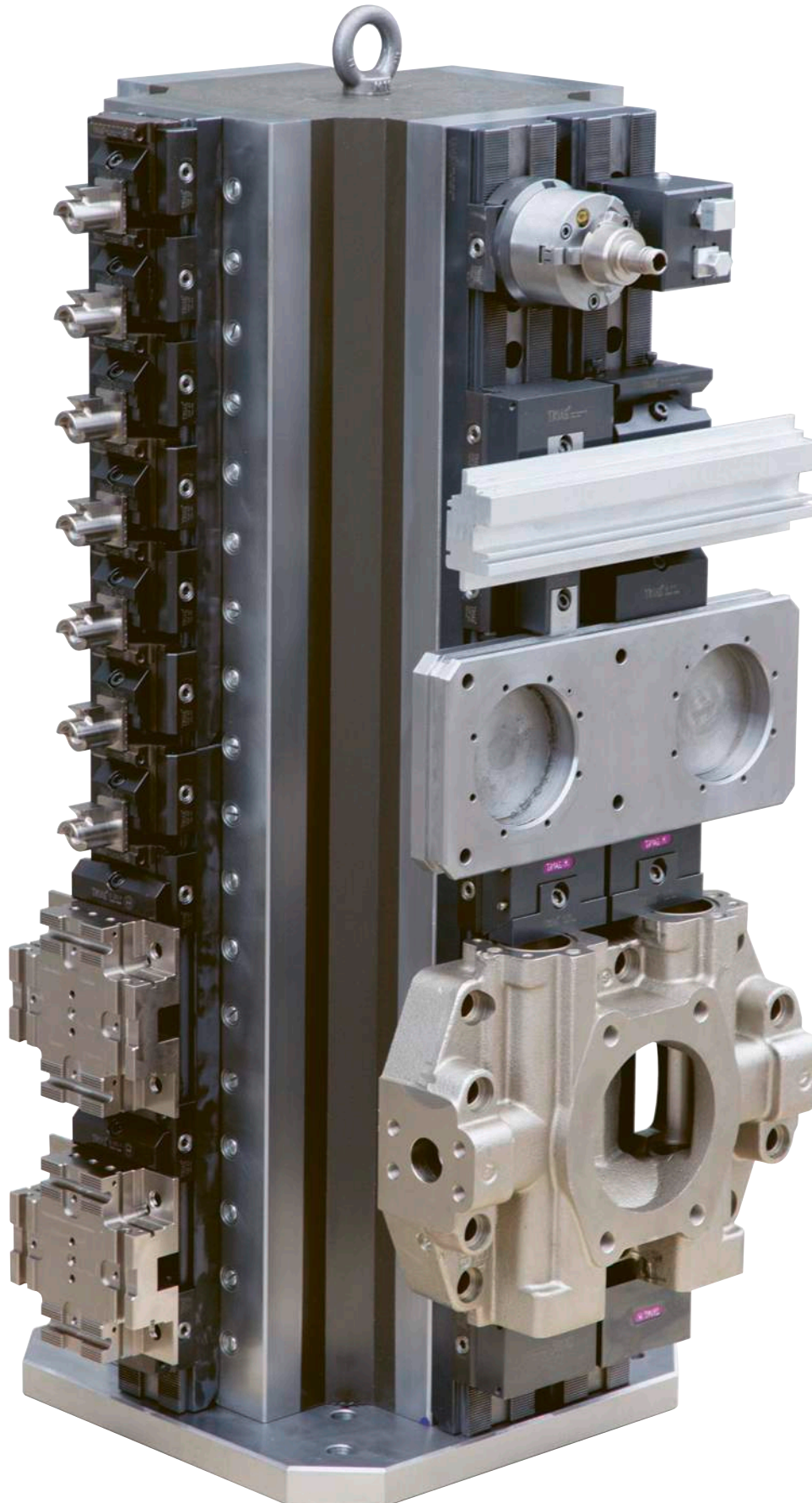

25 tripoxyMINERAL Kreuzturm mit PowerCLAMP Schienen für chaotische Spannung
tripoxyMINERAL Cross version with PowerCLAMP baserails for chaotic workholding

31 tripoxyMINERAL mit unterschiedlichen Werkstücken bestückt
tripoxyMINERAL tombstones holding a variety of workpieces



32 Zentrischspanner auf einem Spezialturm
Centric vices installed on a special tombstone

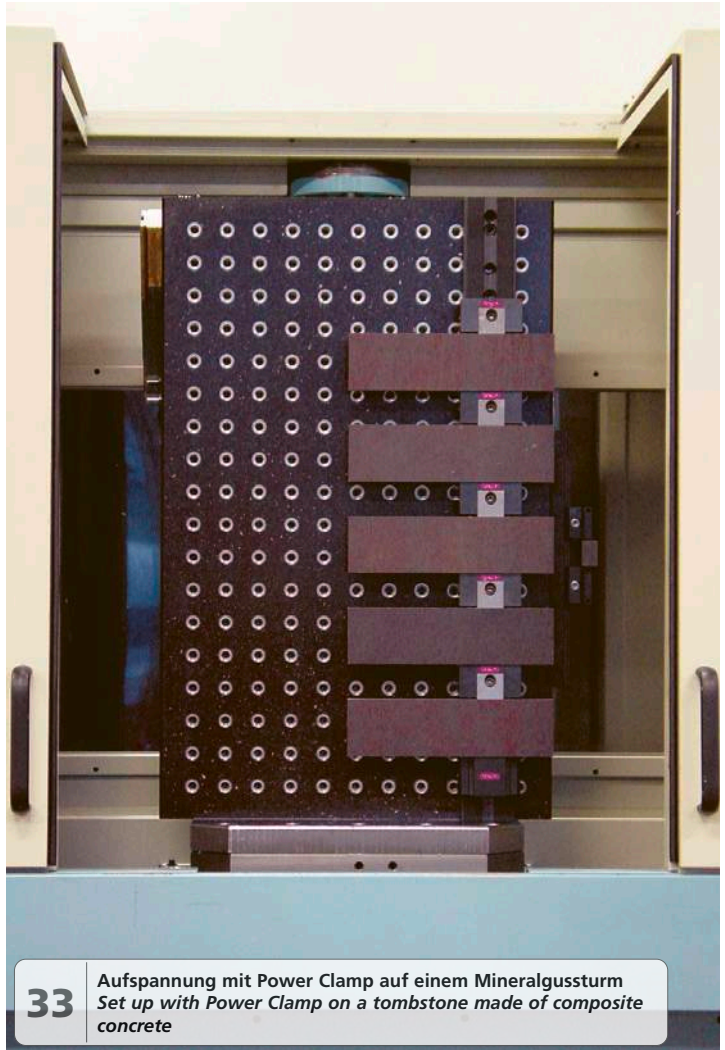

33 Aufspannung mit Power Clamp auf einem Mineralgussturm
Set up with Power Clamp on a tombstone made of composite concrete

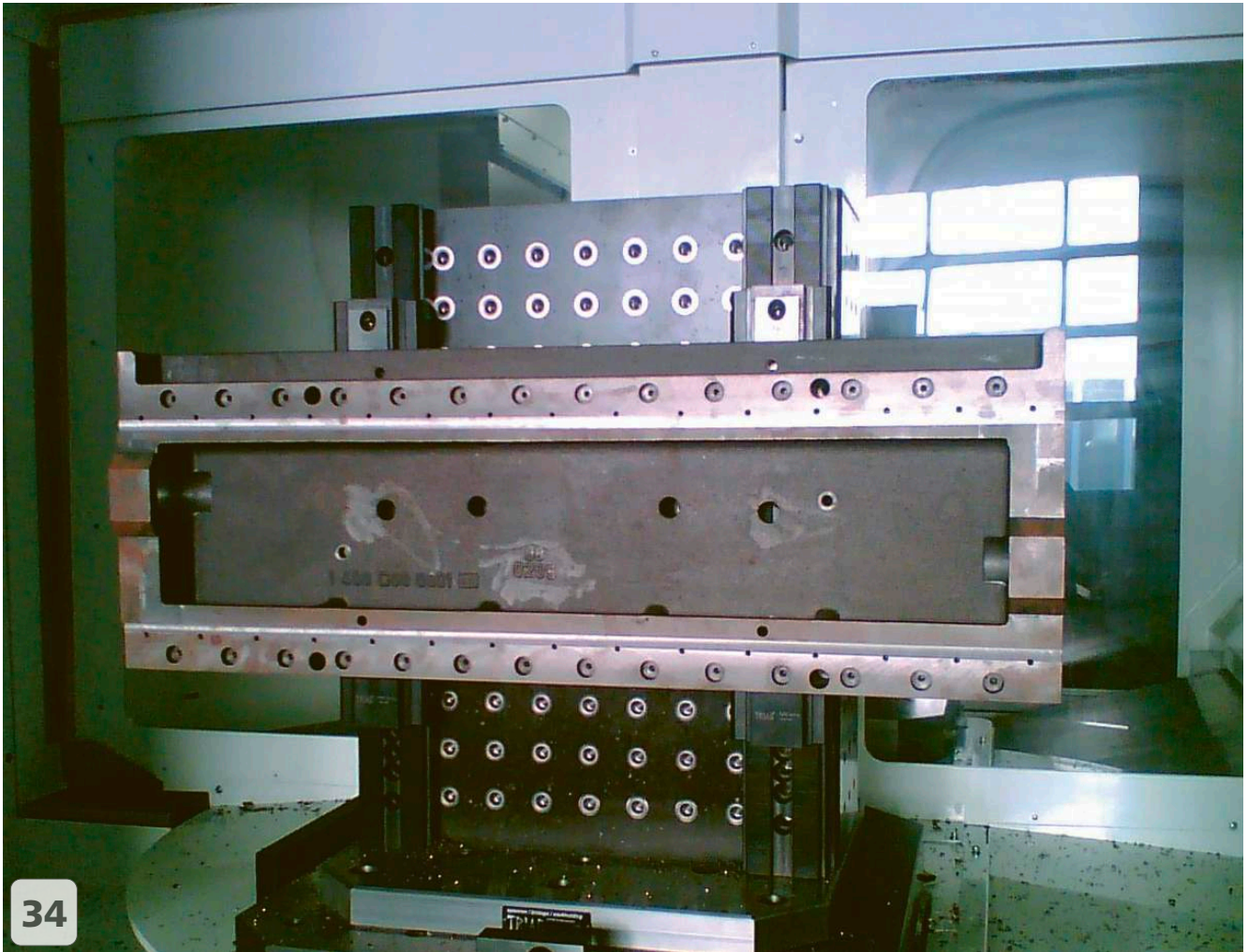

34

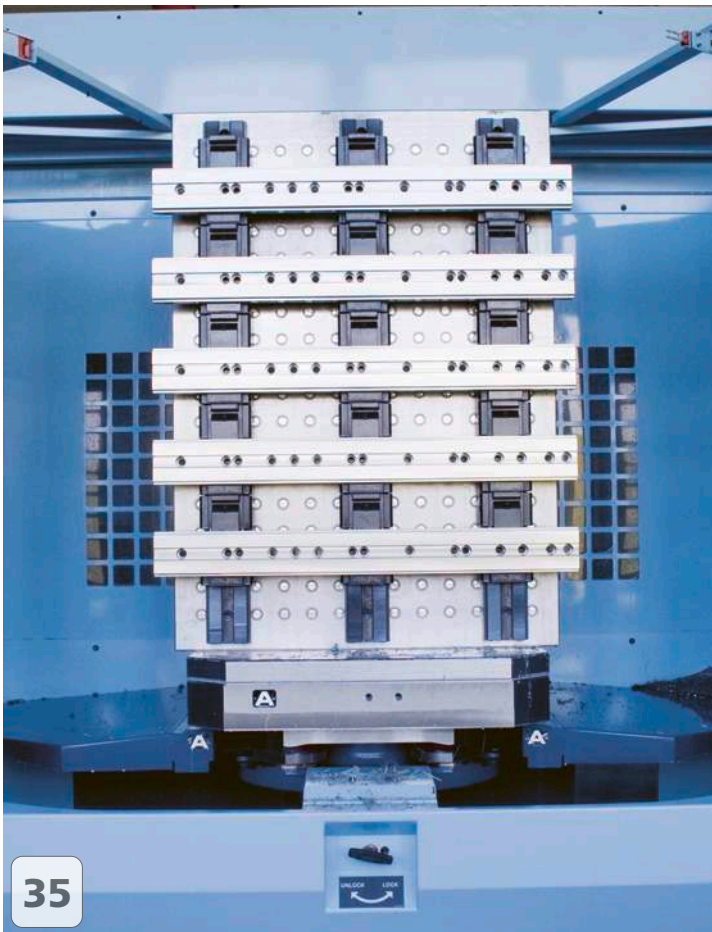

35

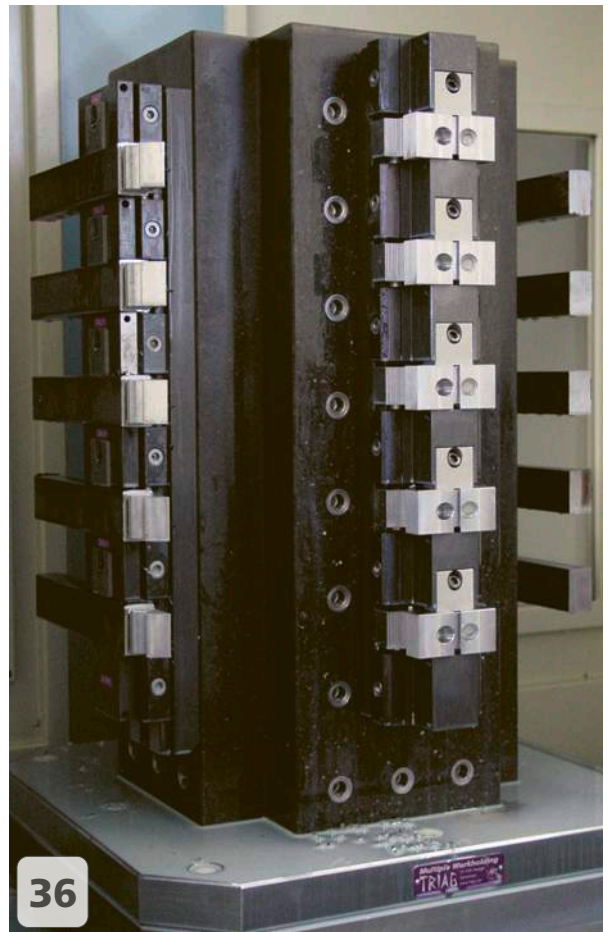

36

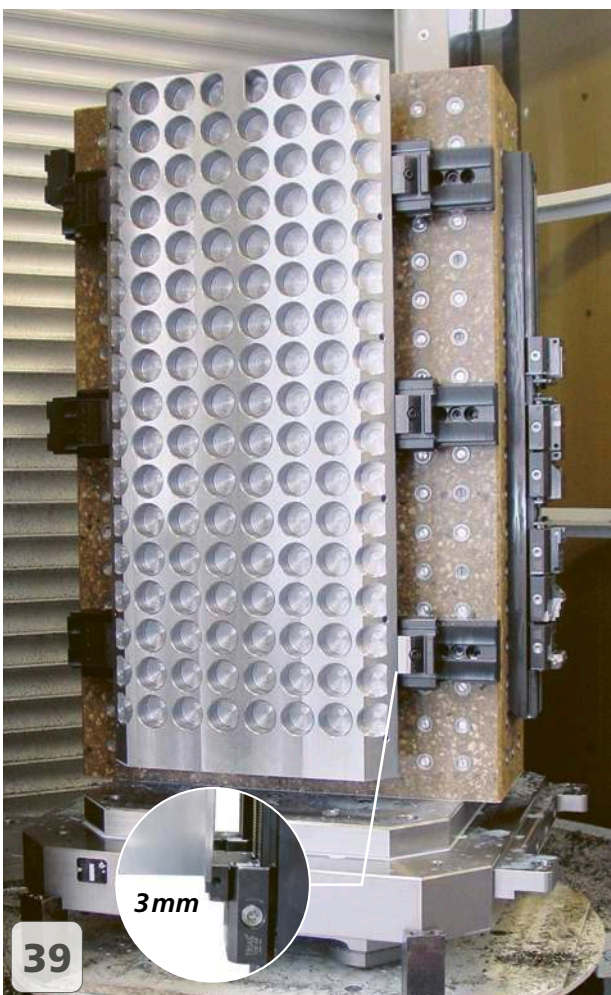
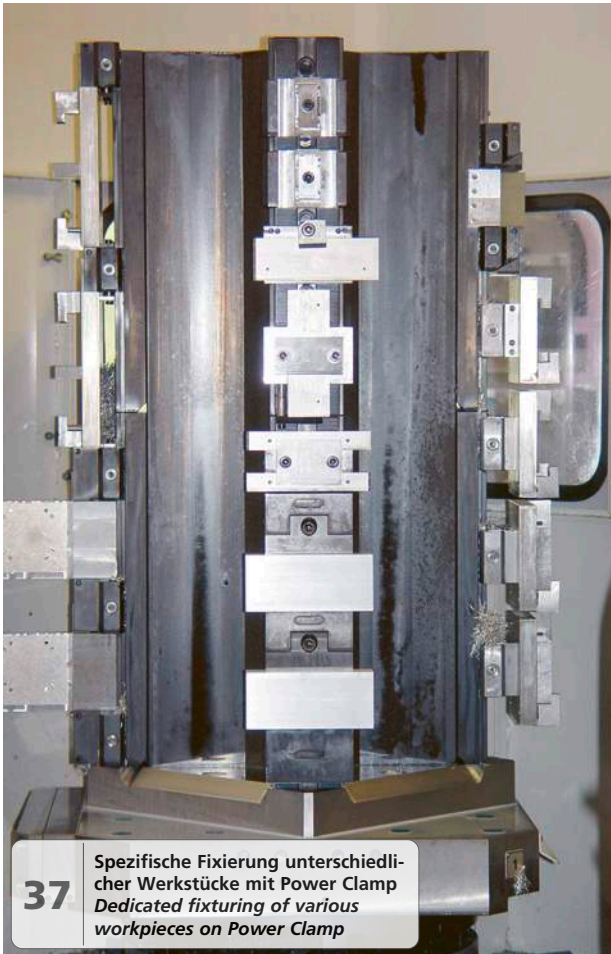

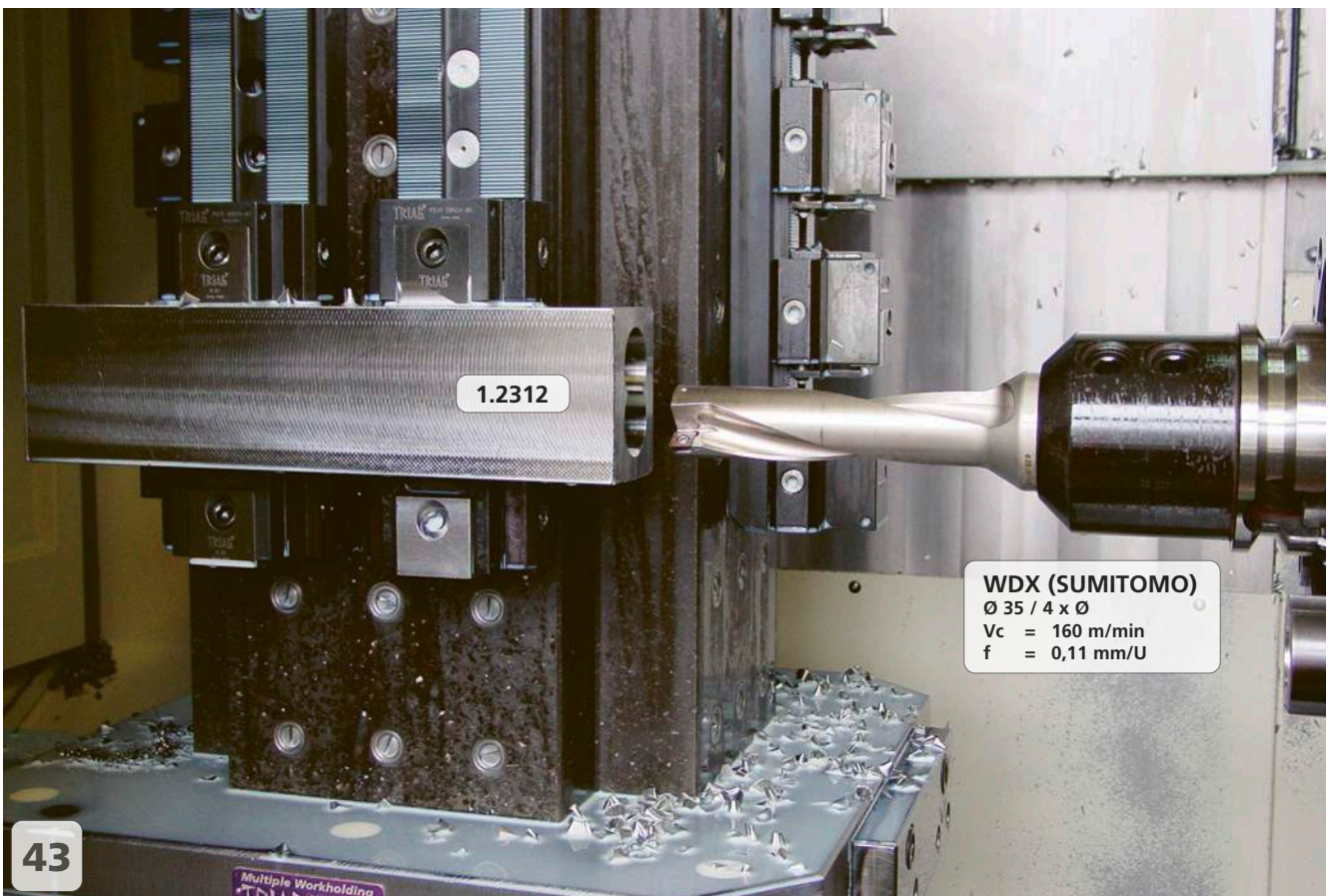
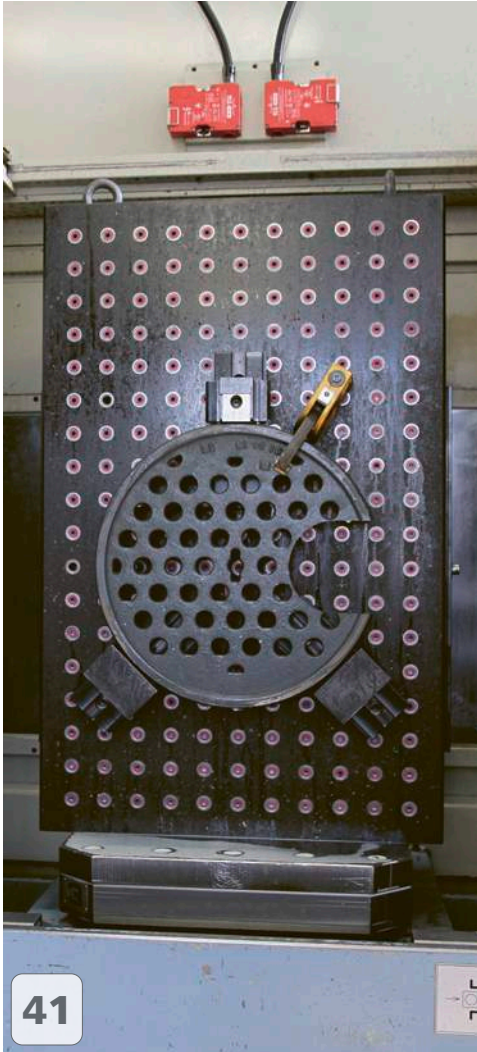



200 x 400 x 1330
Flügelteil für Airbus A320
Tail wing part for Airbus A320

45 Stahlmineralguss-Säulen mit Power Clamp für die Fertigung von Flügelteilen.
Steel epoxy frames machining wing parts on a Makino machine

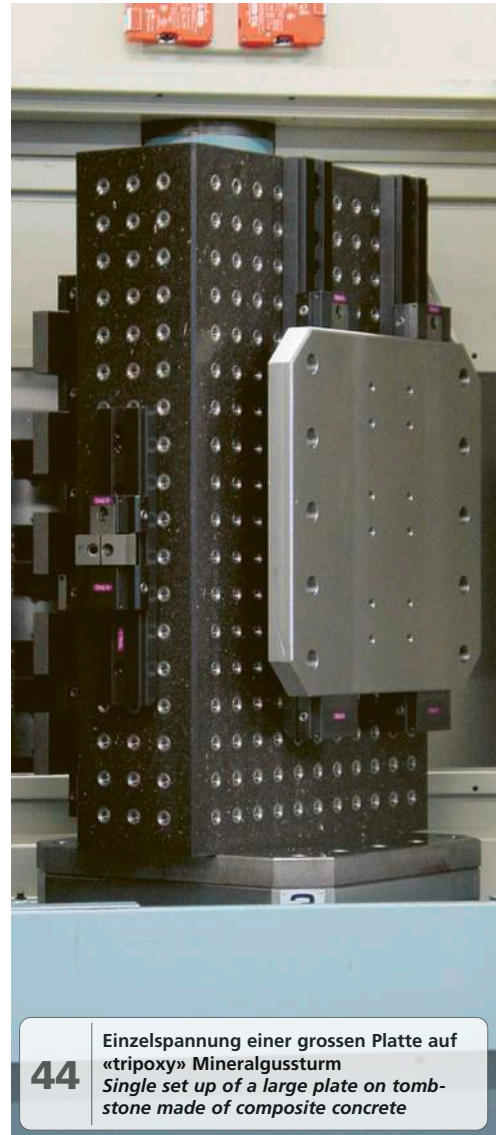

44 Einzelspannung einer grossen Platte auf «tripoxy» Mineralgussturm
Single set up of a large plate on tombstone made of composite concrete



46

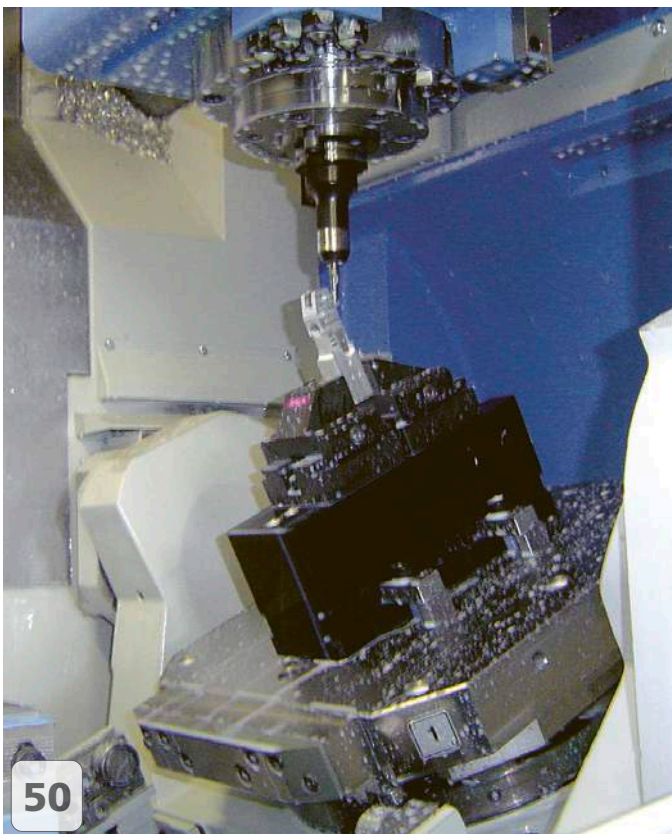
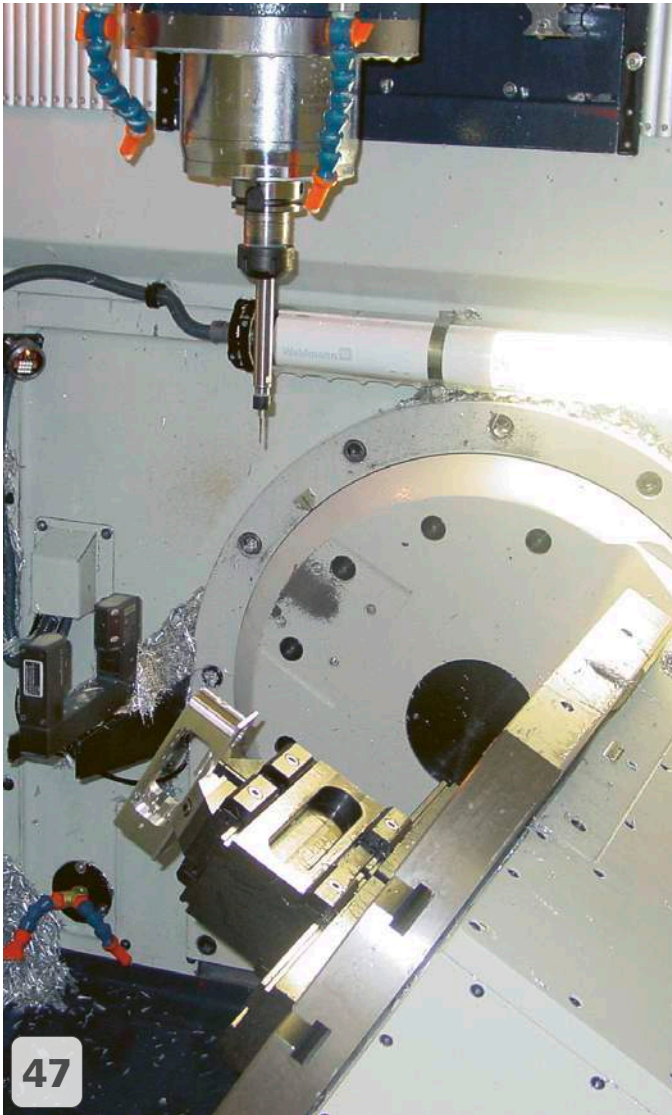

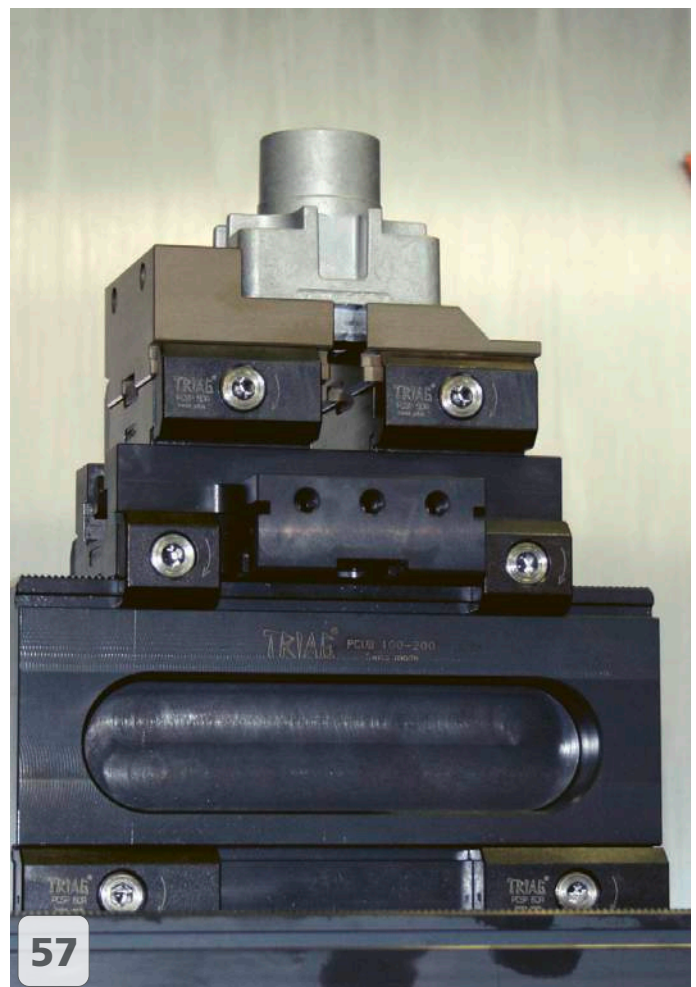
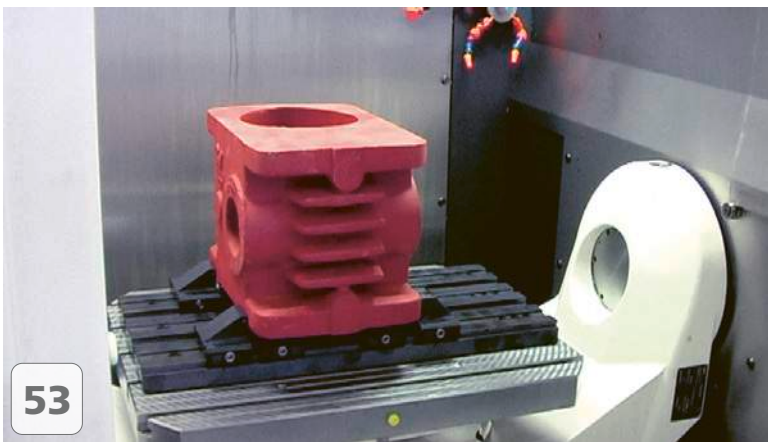

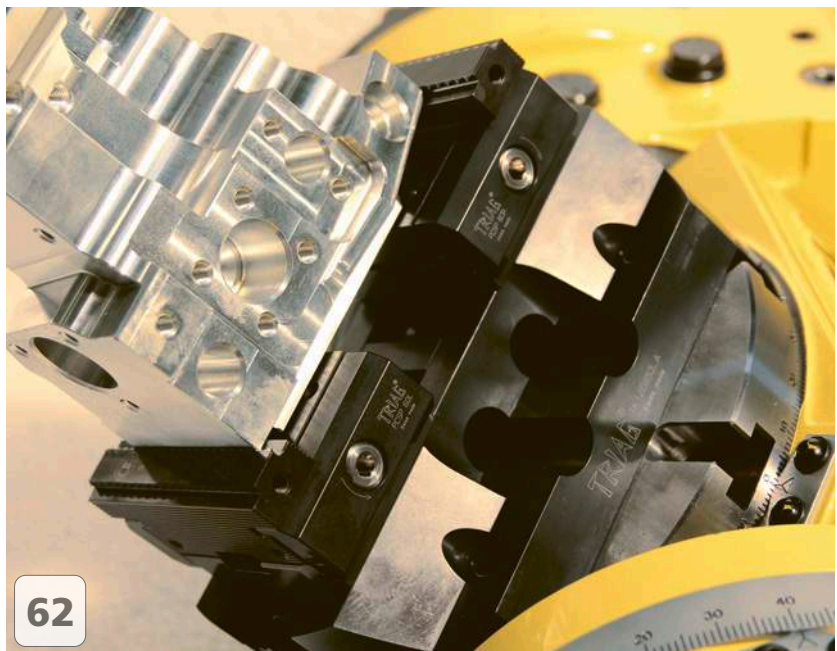
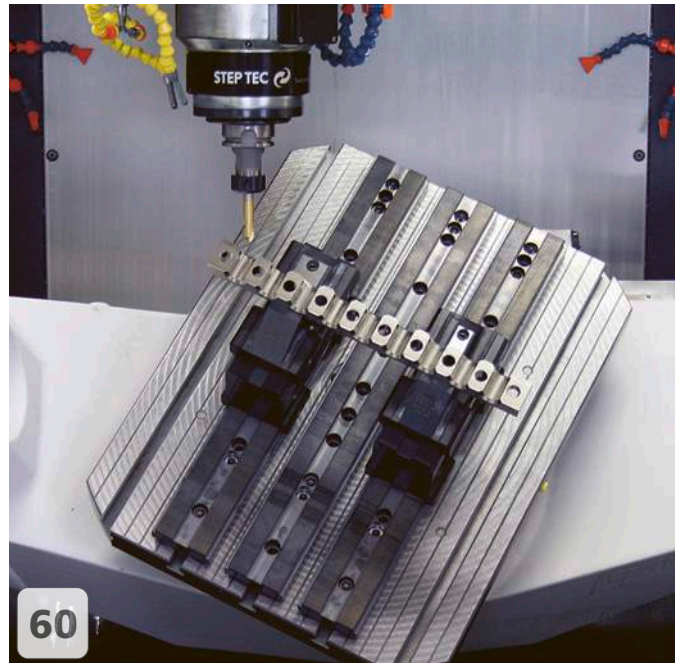
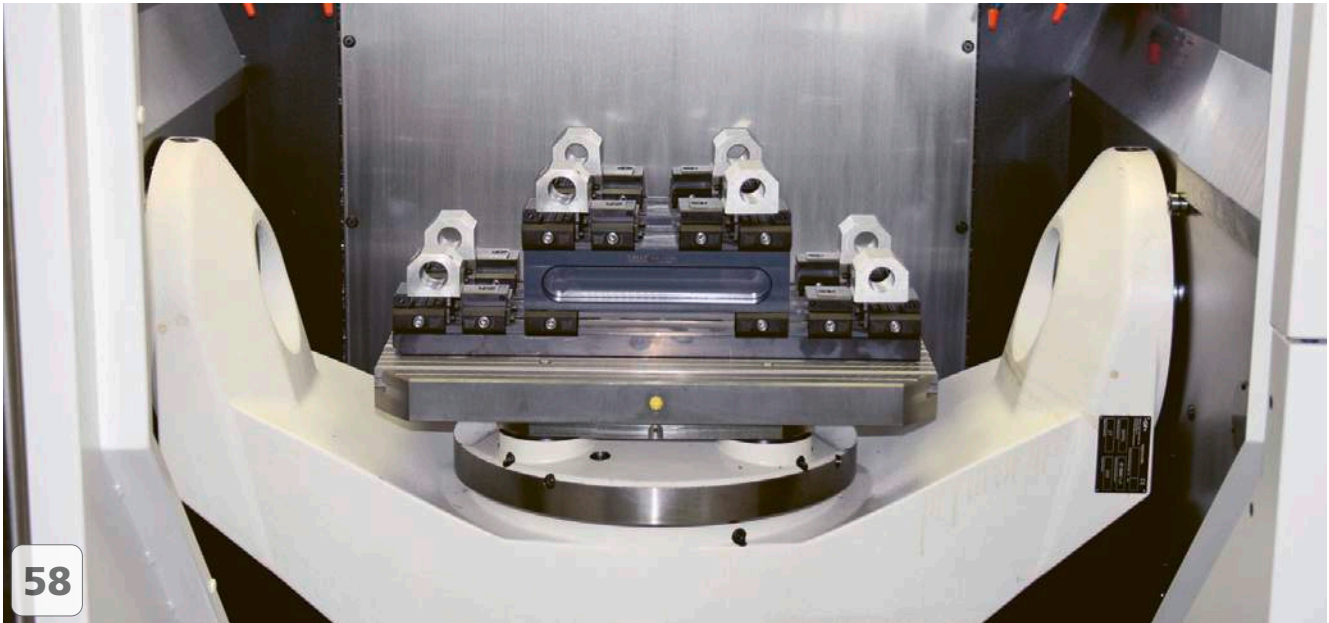

Modulares Mehrfachspannen auf 5-Achsen-Maschinen

Immer öfter werden die 5-Achsen-Maschinen in den Produktionsabläufen eingesetzt, um den Ansprüchen der heutigen effizienten Herstellung gerecht zu werden und weltweit wettbewerbsfähig zu bleiben. Die Werkstückspannung ist sehr anspruchsvoll und fordert die technischen Mitarbeiter ausserordentlich, wie auf den nachfolgenden Bildern dargestellt.

Modular workholding system for 5-axis machines

Increasingly, the 5-axis machines are used in the production processes to be in accordance with the demands of today's efficient manufacturing and remain globally competitive. The workpiece clamping is very demanding and calls for extremely technical staff, as shown on the following pictures.

Vorteile der Triag 5-Achsen Spannsysteme:

- Die unteren Basisschienen dienen sowohl als mechanisches Nullpunktspannsystem, aber auch als Spannstock.
- Die Spannkraft wirkt direkt beim Werkstück, trotzdem ist das Werkstück ob klein, lang oder gross mit kurzen Werkzeugen sehr gut zugänglich. (Die Einschränkung ist der Maschinentisch)!
- Bei der Dreiseitenbearbeitung ist auch Mehrfachspannung möglich.
- Es können über 200 verschiedene Spannmodule, sowie Rohmodule, Zentrischspanner, Dreibackenfutter, Spannzangenfutter, Vakuumspannmodule usw. aufgesetzt werden. Die Schnittstelle ist immer dieselbe.
- Sehr schnelles Umrüsten!
- Wenig Reinigungsaufwand, da keine T-Nuten vorhanden sind.
- Besonders gut geeignet für 5-Achsen-Maschinen. Alle Spannvorrichtungen können auch auf Horizontal- und Vertikalmaschinen universell eingesetzt werden.

Benefits of Triag 5-axis workholding systems:

- The lower base rails serve both as a mechanical zero-point clamping system, but also as a vice.
- The tension acts directly at the workpiece, the workpiece is still, whether small, long or large, very accessible with short tools. The constraint is the machine table!
- 3-side machining is possible as well.
- There may be placed over 200 different clamping modules, as well as raw modules, self-centring modules, three jaw chuck, collet chuck, vacuum clamping modules and so on. The interface is always the same.
- Very fast setup!
- Reduced cleaning required, since no T-slots available.
- Especially suitable for 5-axis machines. All clamping devices can also be used universally on horizontal and vertical machines.



Geeignet sowohl für kleine ...
Especially suited for small ...

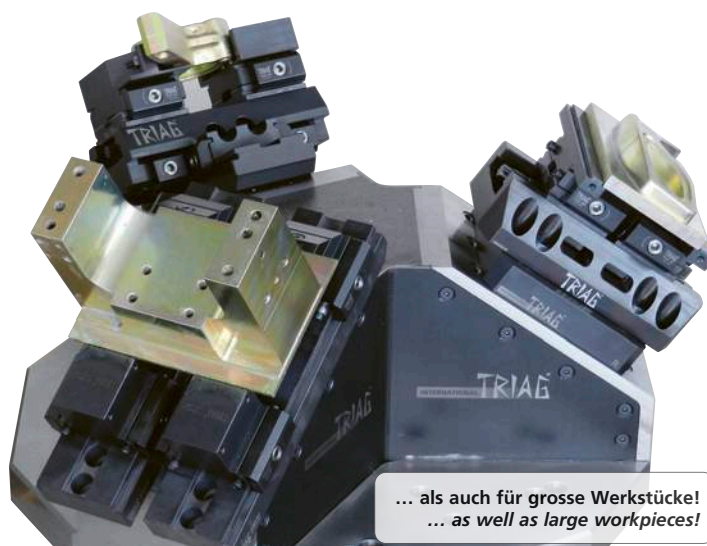

... als auch für grosse Werkstücke!
... as well as large workpieces!

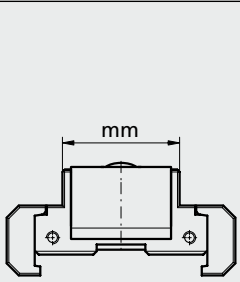
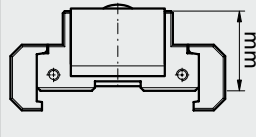
System System		bei Anschlagmodulen for end module		Modulnutzbreite Module clamping width		Modulnutzhöhe Module clamping height	
A	Apto Clamp	N	nitriergehärtet <i>nitrated</i>	19		34	
P	Power Clamp	D	durchgehärtet <i>through hardened</i>	25			
C	Compact Clamp	bei Spanmodulen for vice modules		26			
M	Micro Clamp	1	Anzahl Spannbacken <i>Number of jaws</i>	34			
V	Vorrichtungsbau module <i>Workholding modules for dedicated fixtures</i>	2		43			
		3		48			
		-	keine Spannbacke <i>no clamping jaw</i>	58			
				61			
				68			
				78			

P S 1 R 48 N 34 -80

Modultyp Type of module	
A	Anschlagmodul <i>End module</i>
S	Spannmodul <i>Clamping module</i>
T	Trägermodul <i>Supporting module</i>
R	Rohling <i>Blank</i>

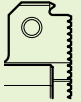
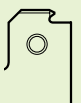
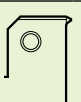
Anschlagfläche der Module Datum face	
F	Anschlagfläche glatt <i>Datum face flat</i>
R	Anschlagfläche geriffelt <i>Datum face double serrated</i>
D	eine Seite glatt, eine Seite geriffelt <i>one face flat, one face double serrated</i>
G	Anschlagfläche gerillt <i>Datum face serrated</i>
X	spezielle Ausführung <i>special execution</i>
5X	5axes Clamp
P	 Fläche unterhalb der Prägung gerillt <i>Area below the stamping serrated</i>
PF	 Fläche unterhalb der Prägung glatt <i>Smooth surface below the stamping</i>
PV	 Präge vorstehend, Fläche unterhalb der Prägung glatt <i>Stamping protruding, surface below the stamping flat</i>
P6	prägen / stamping

Backenhub Stroke of clamping jaw	
N	Niederzug <i>Pull down</i>
L	linear / parallel <i>linear / parallel</i>
-	ohne Spannbacke <i>no clamping jaw</i>

Spannbackentyp Type of clamping jaw	
B01	Spannbacken <i>Clamping jaws</i>
- B313	
-013	Modul ohne Spannbacken <i>Module without clamping jaw</i>
-105	

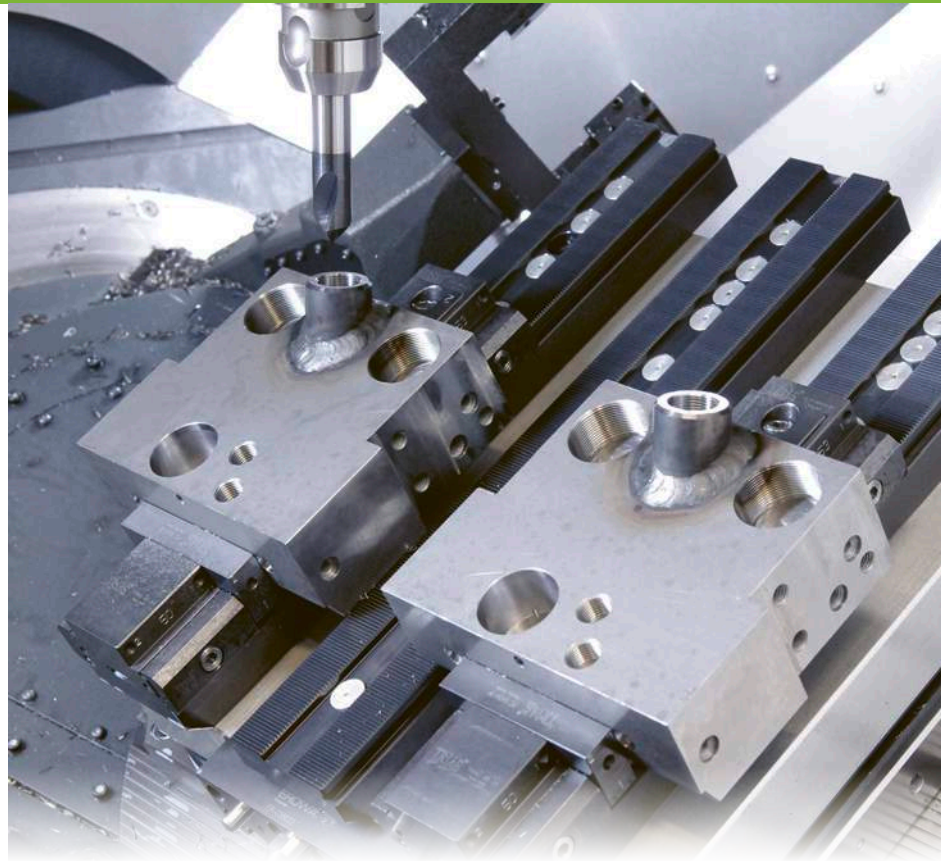

Die Basisschiene ist die Grundlage des Power Clamp Spannsystems

Der Einsatz der Basisschiene als Modularspannstock ist jedem Mechaniker ein Begriff. Die Vorteile ihres Einsatzes als mechanisches Nullpunktsystem sind in der Zwischenzeit ebenfalls ins Planungsdenken der mechanischen Fertigung eingeflossen.

Die Power Clamp-Schiene dient als Basis für über 200 verschiedene Spannmodule, Zentrischspanner, Rohlingsmodule und Vakuumplatten.

The serrated base rail is the basic structure of the Power Clamp workholding system

Using the base rail as a modular workholding vise is standard practice to any mechanic. The advantages of using it as a zero point system have also widely influenced the planning stages of mechanical production.

The Power Clamp base rail serves as a supporting plate for more than 200 different clamping modules, self centring vises, blank modules and vacuum clamping plates.

Toleranz gilt für alle PCB-Basisschienen / Tolerance applies to all PCB base rails

Toleranzklassen
Tolerance classes

P6	+0.06
P5	+0.05
P4	+0.04
P3	+0.03
P2	+0.02
P1	+0.01
P0	+0.005
M0	-0.005
M1	-0.01
M2	-0.02
M3	-0.03
M4	-0.04
M5	-0.05
M6	-0.06

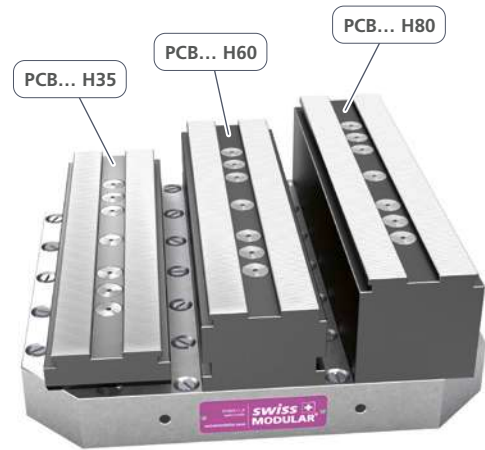
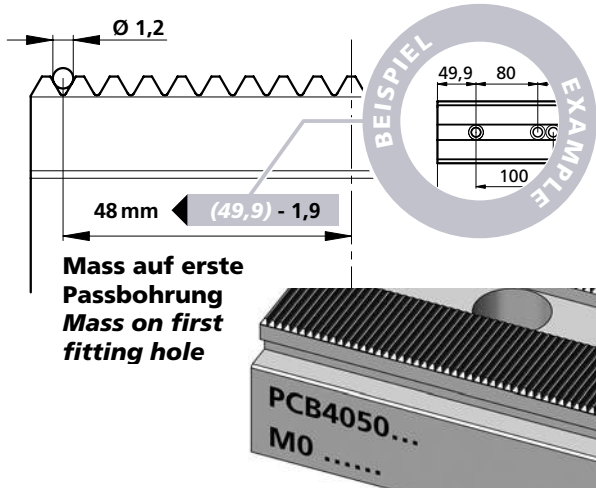

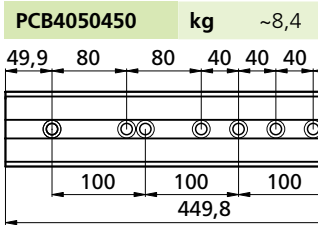
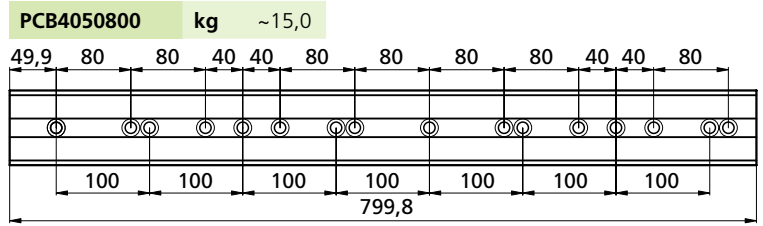
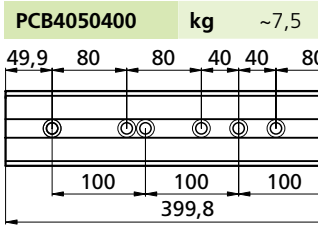
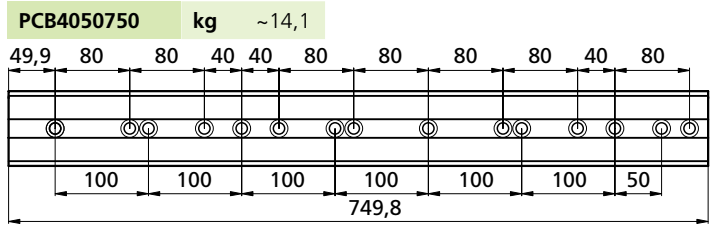
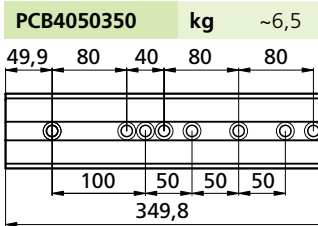
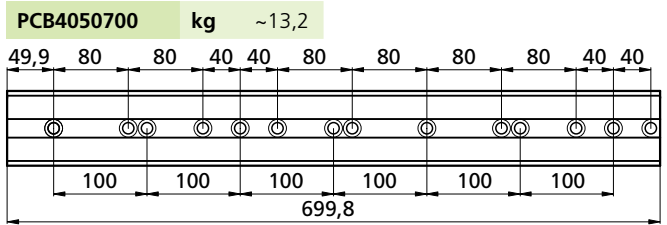
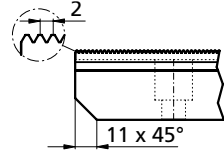
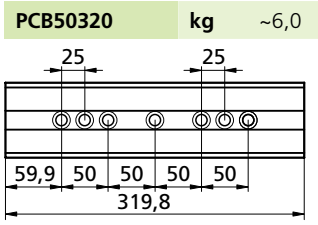
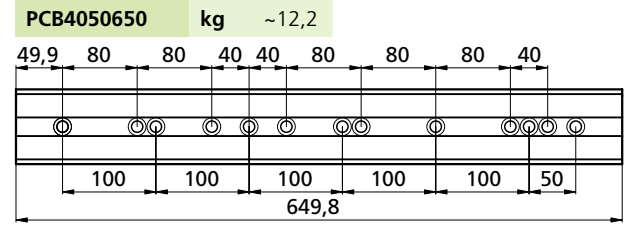
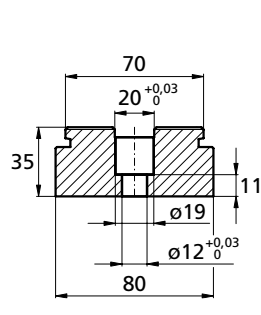
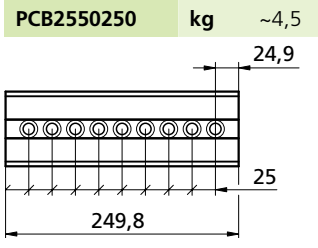
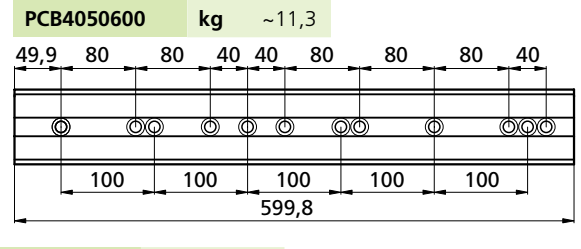
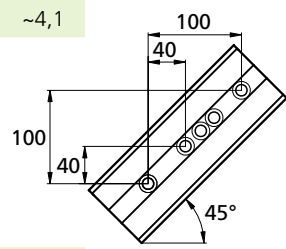
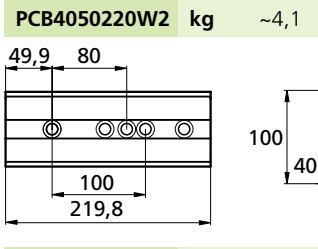
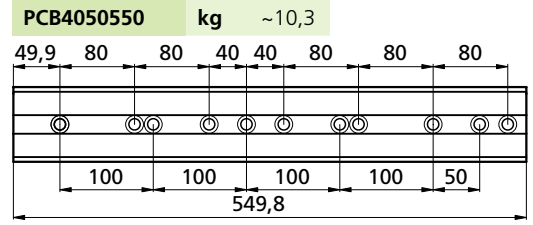
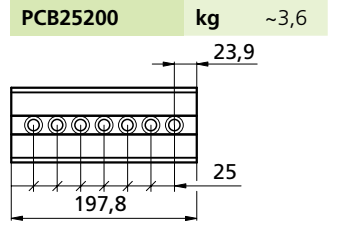
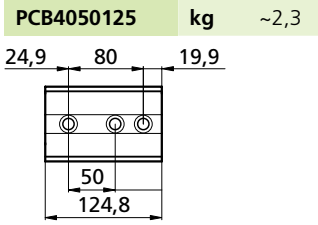
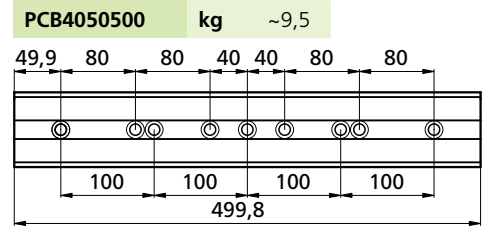
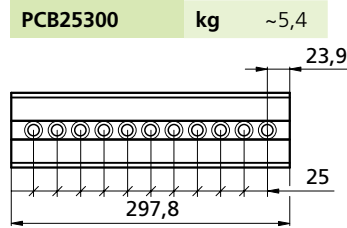
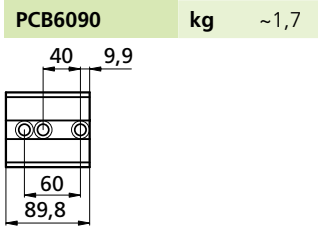

Basisschienen in Zoll
Base rails in inch



Bestellbeispiel / Ordering example: **PCB4050125**

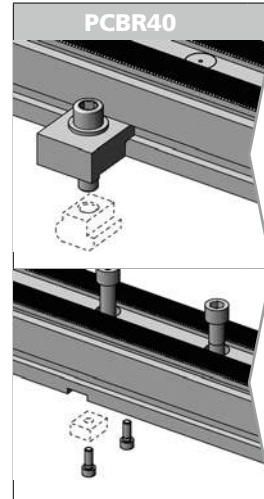
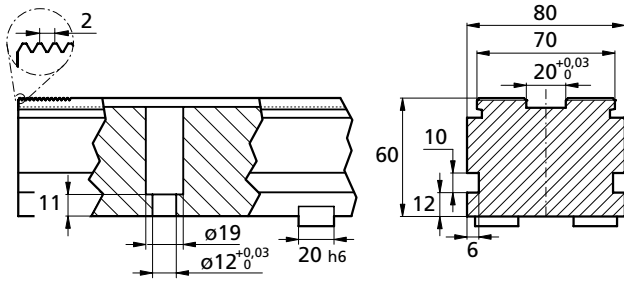

1. Befestigung 1. Fastening
Mit den seitlichen Pratten, kann die Basisschiene frei auf Ihrem Maschinentisch montiert werden.
With the lateral clamps, the base-rail can be mounted freely on your machine table.

2. Befestigung 2. Fastening
Diese Nutensteine sind zum Ausrichten der Basisschiene auf Ihrem Maschinentisch.
These t-slot nuts are for aligning the base-rail on your machine table.

PCB50320H60	
1	1x TF190449
2	2x M6X12ISO4762
3	2x SM1136-20
kg	~10,3

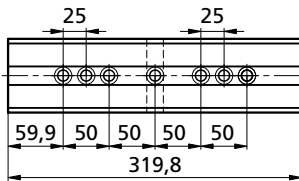

PCB100350H60	
1	1x TH170888
2	2x M6X12ISO4762
3	2x SM1136-20
kg	~11,7

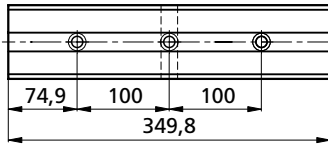

PCB100400H60	
1	1x TB140546
2	2x M6X12ISO4762
3	2x SM1136-20
kg	~13,4

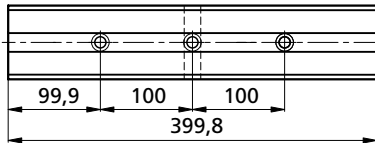

PCB100500H60	
1	1x TB140553
2	2x M6X12ISO4762
3	2x SM1136-20
kg	~16,7

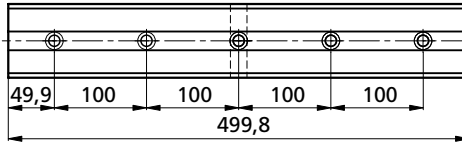

PCB100600H60	
1	1x TB140556
2	2x M6X12ISO4762
3	2x SM1136-20
kg	~20,1

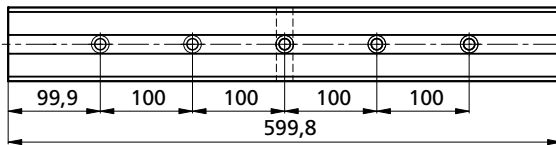

PCB100650H60	
1	1x TB140559
2	2x M6X12ISO4762
3	2x SM1136-20
kg	~21,8

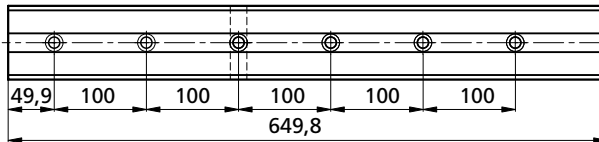

PCB100690H60	
1	1x ZL100122
2	2x M6X12ISO4762
3	2x SM1136-20
kg	~22,6

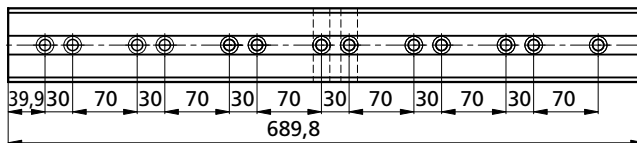

PCB100850H60	
1	1x TB140562
2	2x M6X12ISO4762
3	2x SM1136-20
kg	~27,9

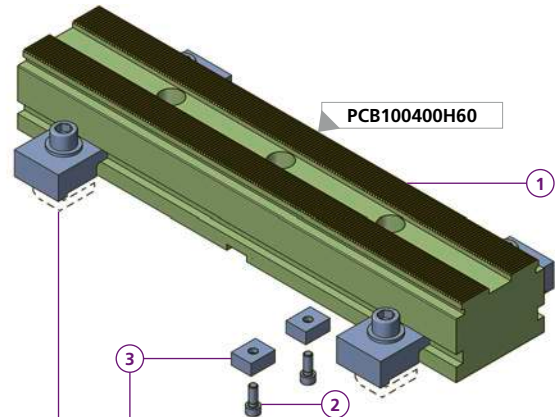
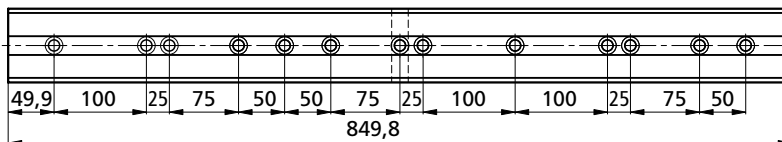

Zubehör / Accessories p. 338

PCBR40	
4	1x M12X45ISO4762
5	1x TN100251
6	1x TK200035
kg	~0,25

T-Nutensteine T-slot nuts
T-Nutensteine je nach Maschinentisch, muss separat bestellt werden.
T-slot nuts depending on the machine table, must be ordered separately.

Bestellbeispiel / Ordering example: 1x PCB100400H60 & 2x M6X12ISO4762 & 2x SM1136-20

PCB4050125H80 kg ~5,5

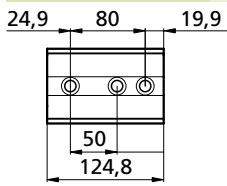

PCB50320H80 kg ~14,3

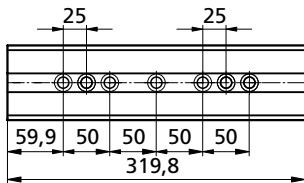

PCB50350H80 kg ~15,8

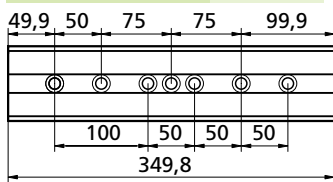

PCB50400H80 kg ~18,1

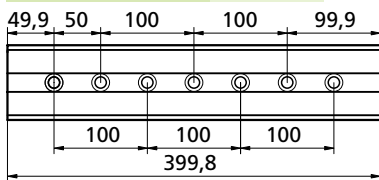

PCB50450H80 kg ~20,2

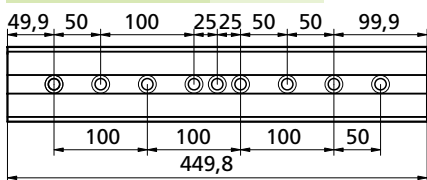

PCB50500H80 kg ~22,6

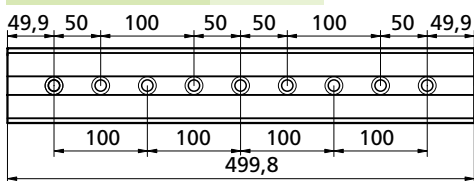

PCB50550H80 kg ~24,7

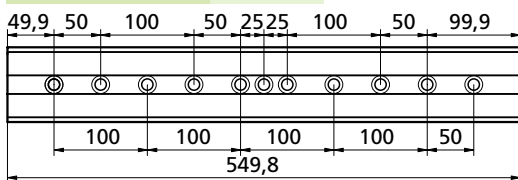

PCB50600H80 kg ~27,3

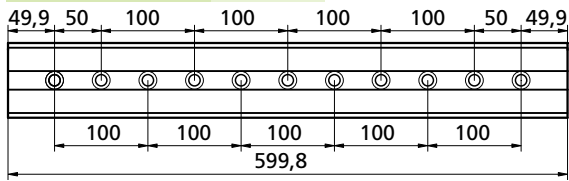

PCB50650H80 kg ~29,2

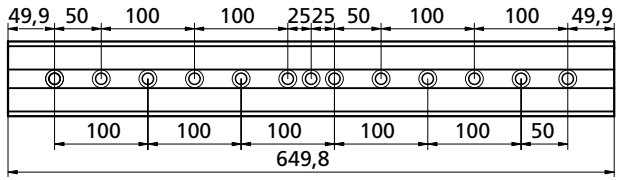

PCB50700H80 kg ~31,5

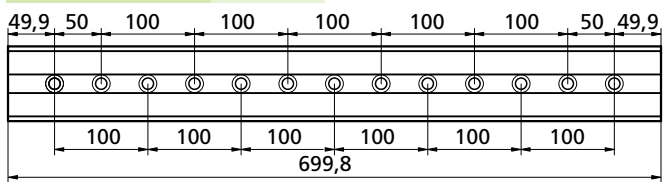

PCB50750H80 kg ~33,9

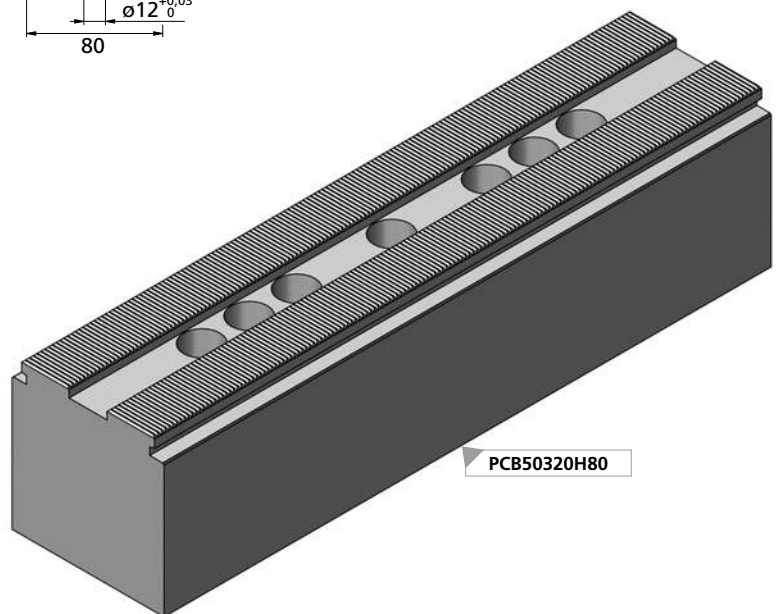
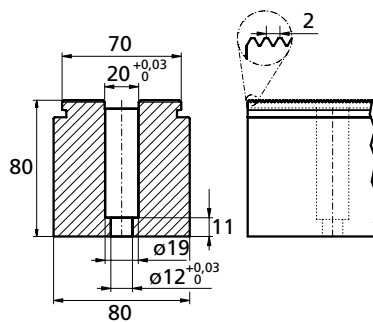
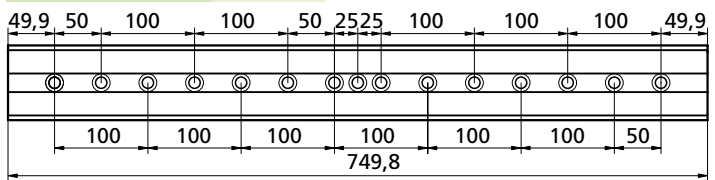

PCB50320H80

PCMB50600H175 kg ~39

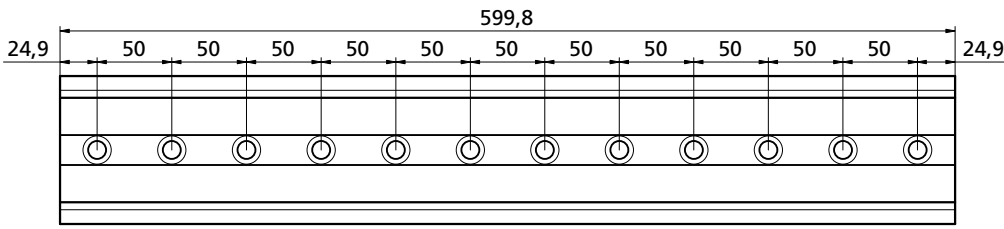

PCMB50500H175 kg ~34

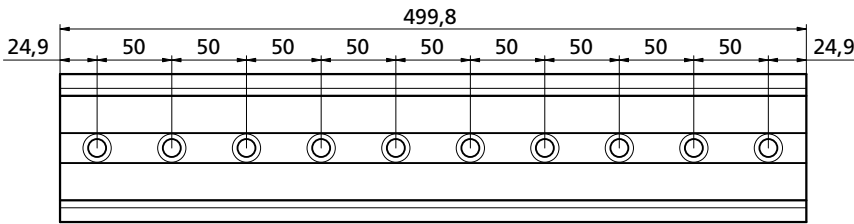

PCMB50400H175 kg ~27

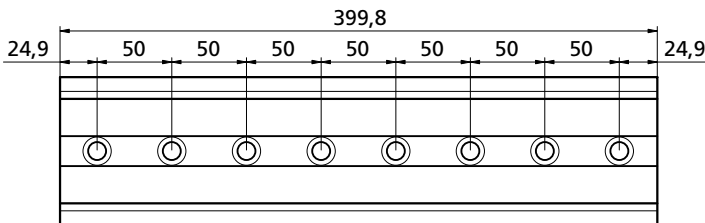

PCMB50300H175 kg ~22

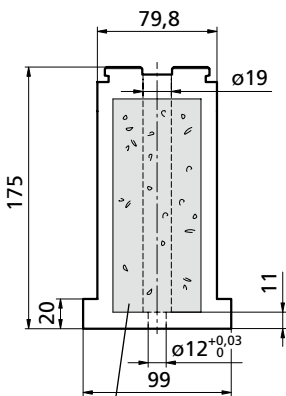
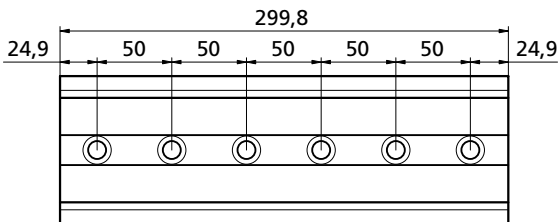

Epoxy Mineral
 Für gute Vibrationsdämpfung
 For brilliant dampening effect



Kupplungsstück (Basisschienen zum koppeln) Coupling element (Base rails for coupling)

powerCLAMP

Kupplungsstücke für PCB Basisschiene auf Mineralgus-Türmen

Mit diesen Kupplungsstücken ist es möglich, die PCB Basisschienen zu verlängern. Aufgrund des durchgängigen Kraftschlusses wird eine übermäßige Belastung des Mineralgussturmes vermieden. Erforderlich ist eine Modifikation der Enden der Basisschienen gemäss der untenstehenden Zeichnung durch den Anwender. Selbstverständlich können neue Schienen bereits mit dieser Modifikation ausgeliefert werden.

So können die zwei Kupplungsstücke montiert werden, die nach dem Platzieren der Schienen eingesetzt und festgezogen werden. Eine zusätzliche Schraube (B) nimmt allfällige, senkrecht zur Befestigungsfläche auftretende Kräfte auf.

Coupling element for PCB base rails mounted on epoxy mineral tombstones

With this coupling element, it is possible to extend the PCB base rail by a second rail. Due to the frictional connection, the behaviour of the associated items is approximate to the behaviour of a continuous rail. A modification according to the drawing below (made by the customer) is required at the end of the base rails. New base rails can be supplied with this modification.

So the two coupling elements can be placed between the base rails. An additional screw (B) is taken the force flatwise to the seating.

Detailzeichnung zum Bearbeiten aller Basisschienen H35, um die Aussparung für das Kupplungsstück bei vorhandenen Schienen nachträglich herzustellen.

Detail drawing for machining all base rails H35 to retrofit the recess for the coupling piece on existing rails.

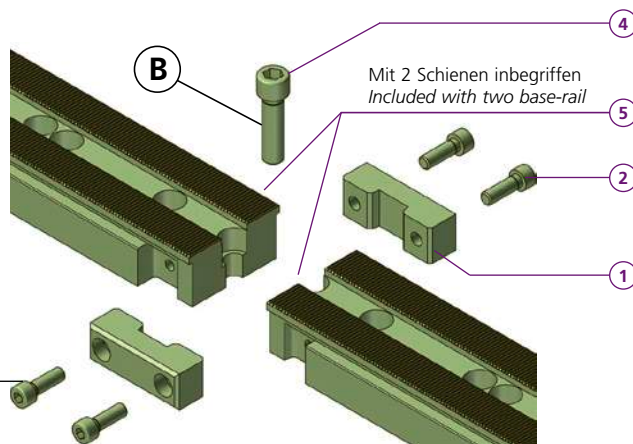
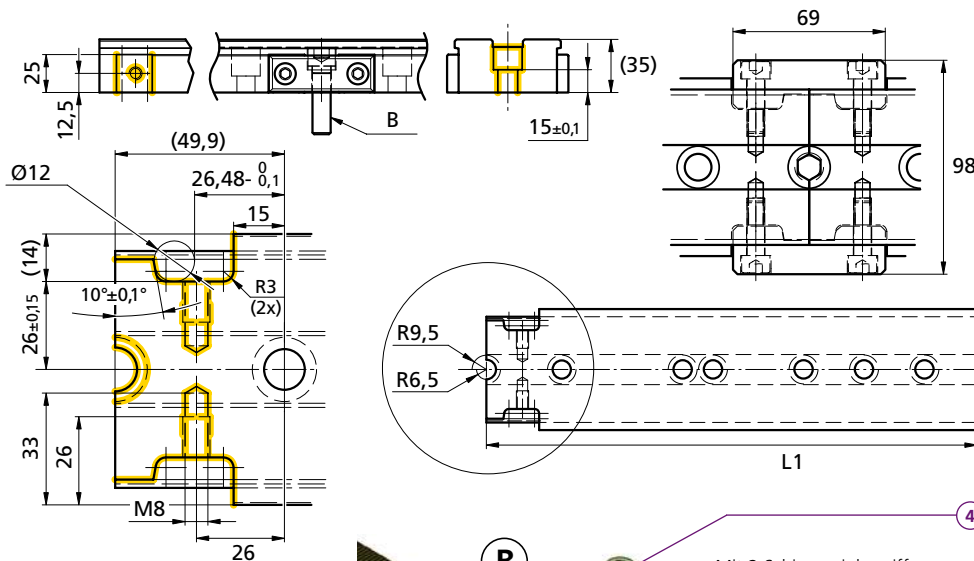

Montageanleitung siehe Video
Assembly instructions see video



PCBP69SET		PCB4050250KP	PCB4050400KP	PCB4050450KP	PCB4050500KP	PCB4050650KP	PCB4050700KP
1	2x TW090078	5	5	5	5	5	5
2	4x M8X25ISO4762	L1 = 250	L1 = 400	L1 = 450	L1 = 500	L1 = 650	L1 = 700
4	1x M12X45ISO4762	kg ~5,1	kg ~7,9	kg ~8,9	kg ~9,9	kg ~12,8	kg ~13,8
kg	~0,4						

Bestellbeispiel / Ordering example: PCB4050250KP

PCB850SET	PCB900SET	PCB950SET	PCB1000SET
1	1	1	1
1x PCB4050400KP	1x PCB4050650KP	1x PCB4050700KP	2x PCB4050500KP
2	2	2	3
1x PCB4050450KP	1x PCB4050250KP	1x PCB4050250KP	1x PCBP69SET
3	3	3	4
1x PCBP69SET	1x PCBP69SET	1x PCBP69SET	4x TWPAS1240
4	4	4	5
4x TWPAS1240	4x TWPAS1240	4x TWPAS1240	6x M12X40ISO4762
5	5	5	6
5x M12X40ISO4762	6x M12X40ISO4762	7x M12X40ISO4762	10x PCPF16L6
6	6	6	7
9x PCPF16L6	10x PCPF16L6	11x PCPF16L6	8x PCPF16L18
7	7	7	kg
9x PCPF16L18	12x PCPF16L18	12x PCPF16L18	~20,9
kg	kg	kg	
~17,8	~18,7	~19,8	

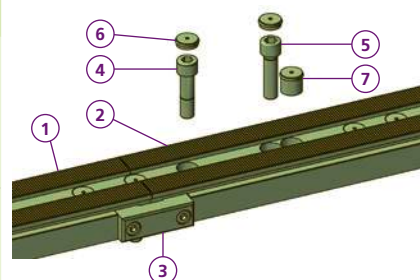

Bestellbeispiel / Ordering example: PCB850SET

Querschiene 90° Crossbar 90°

PCB250Q90-H35

powerCLAMP

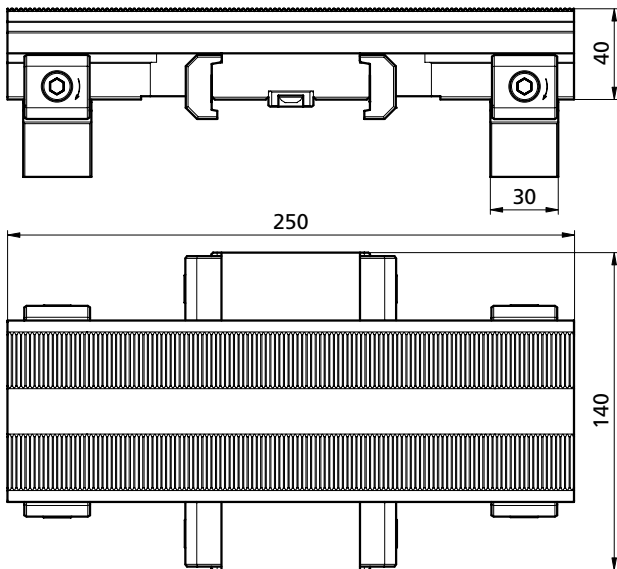
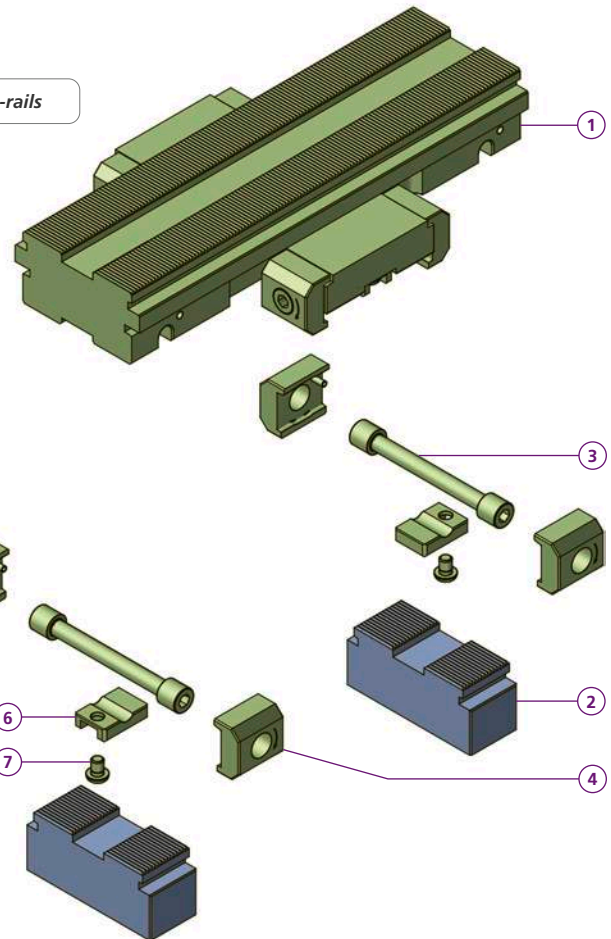
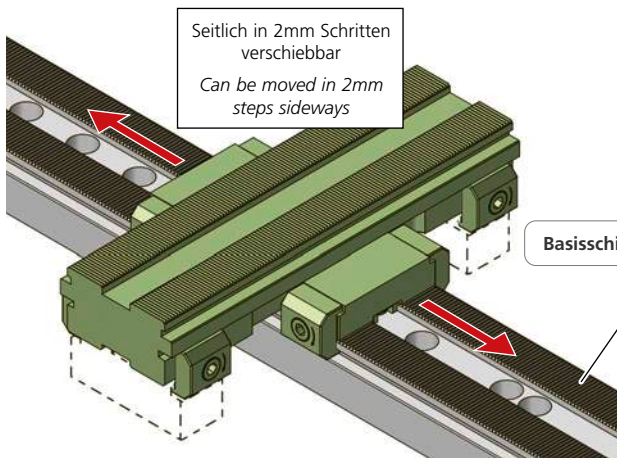

PCB250Q90H35	
①	1x TH151032
②	2x
③	4x PCS14
④	4x PCSP30L
⑤	4x PCSP30R
⑥	4x PCGU2030
⑦	1x M6X8ISO7380
kg	~8,18

Schienenhöhe / Rail height

AS35 (H = 35)	AS60 (H = 60)	AS80 (H = 80)

Seitliche Stützen

Bei Gebrauch der Querschiene 90°, werden je nach Höhe der Basisschiene auf dessen sie aufgesetzt sind, zwei seitliche Stützen AS35 / AS60 / AS80 unterlegt.

Side support

When using the cross rail 90°, a side support AS35 / AS60 / AS80 is underlaid, depending on the height of the base rail on which it is placed.

Bestellbeispiel / Ordering example: PCB250Q90H35

Separat bestellen / Order separately

Erhöhung für 5-Achsenmaschinen Riser for 5-axis machines

PCUB60-130
PCUB100-200
PCUB100-300

powerCLAMP

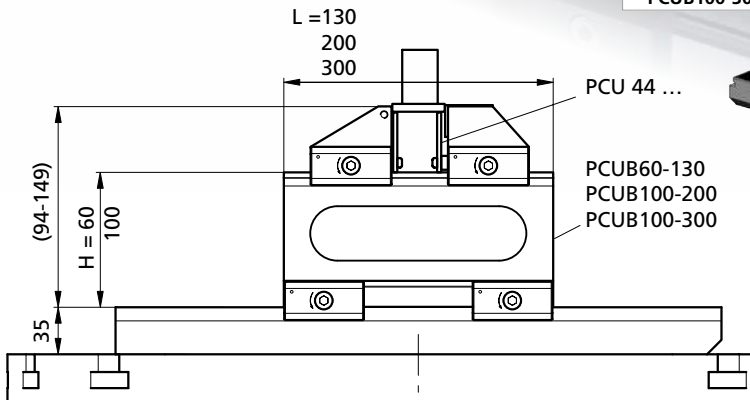
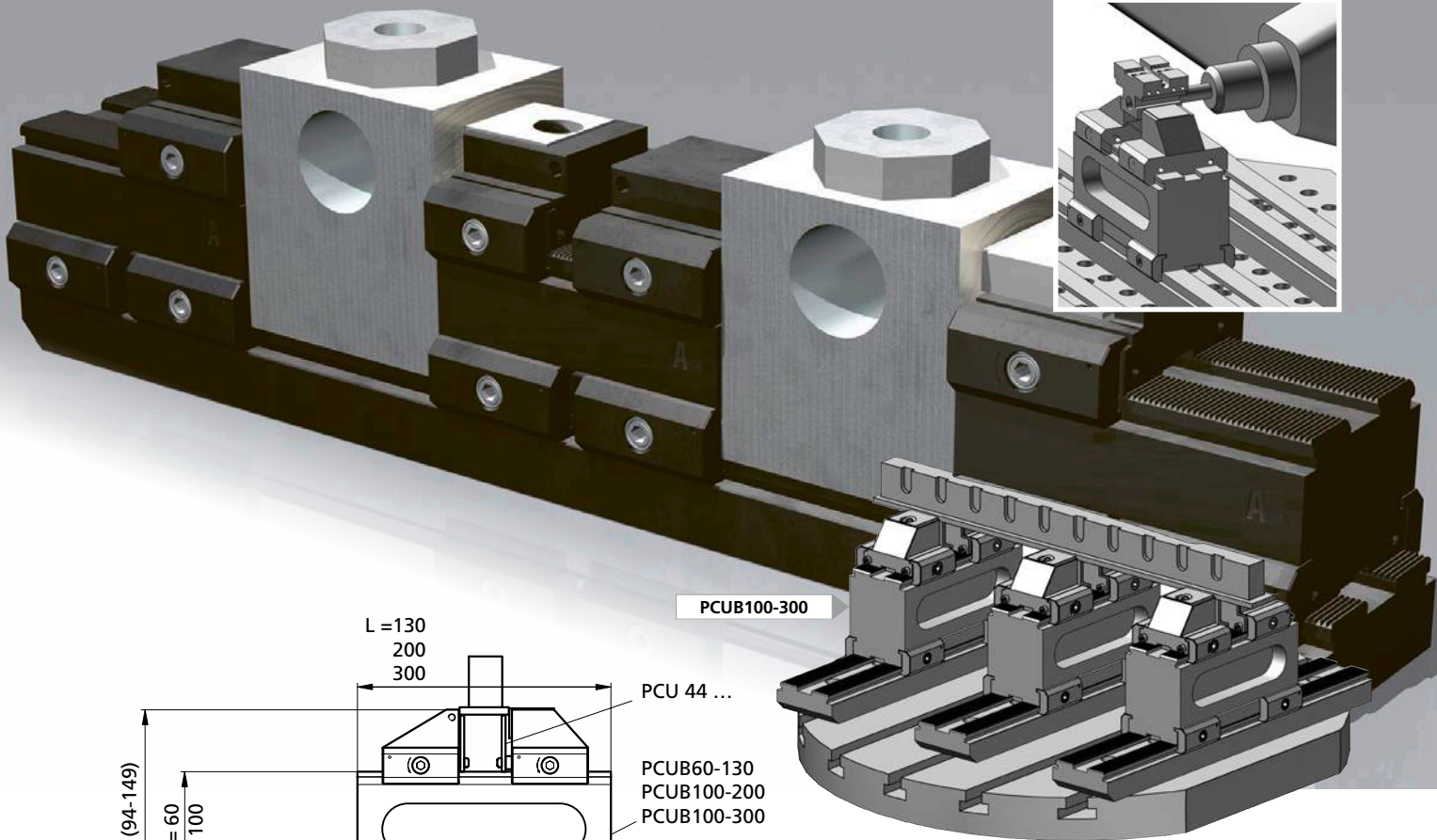

- | PCUB60-130 | |
|-------------|----------------|
| ① | 1x TK120596 |
| ③ | 2x PCSP60R |
| ④ | 2x PCSP60L |
| ⑤ | 2x PCS14 |
| ⑥ | 2x PCGU2049 |
| ⑦ | 2x M6X8ISO7380 |
| L | = 130 |
| H | = 60 |
| kg | ~5,8 |
| PCUB100-200 | |
| ① | 1x TK130108 |
| L | = 200 |
| H | = 100 |
| kg | ~10,5 |
| PCUB100-300 | |
| ① | 1x TK130109 |
| ③ | 3x PCSP60R |
| ④ | 3x PCSP60L |
| ⑤ | 3x PCS14 |
| ⑥ | 3x PCGU2049 |
| ⑦ | 3x M6X8ISO7380 |
| L | = 300 |
| H | = 100 |
| kg | ~16 |

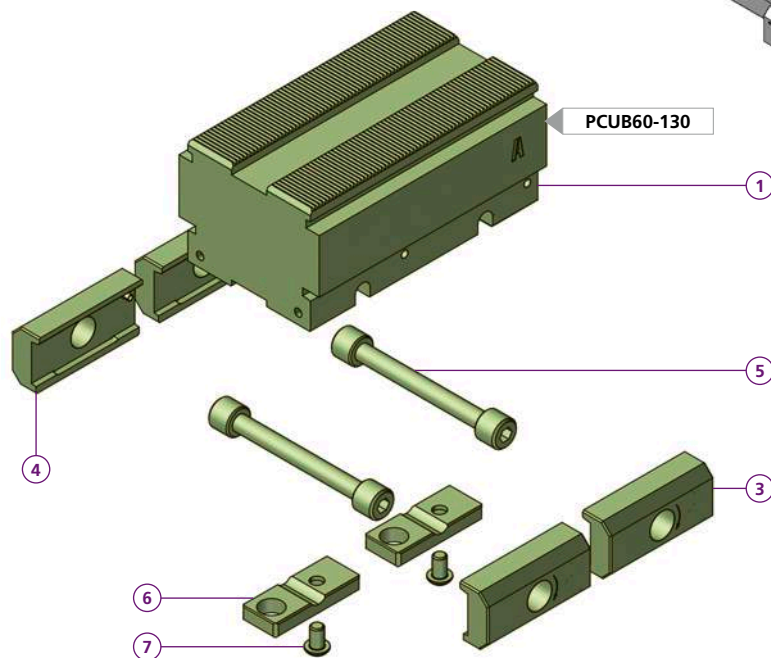

Bestellbeispiel / Ordering example: **PCUB100-200**

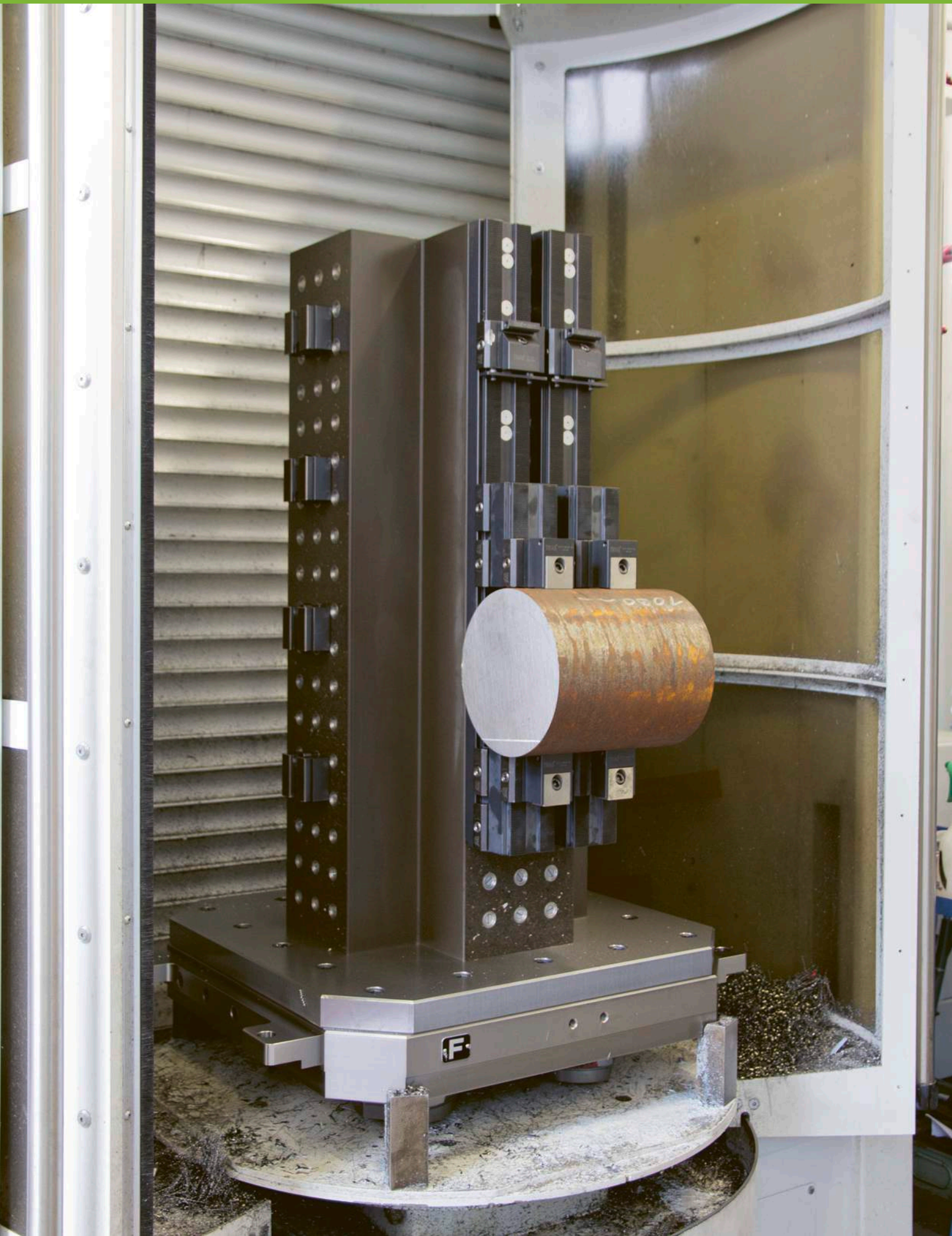

PCUB115-200-R25

PCUB115-300-R25

powerCLAMP

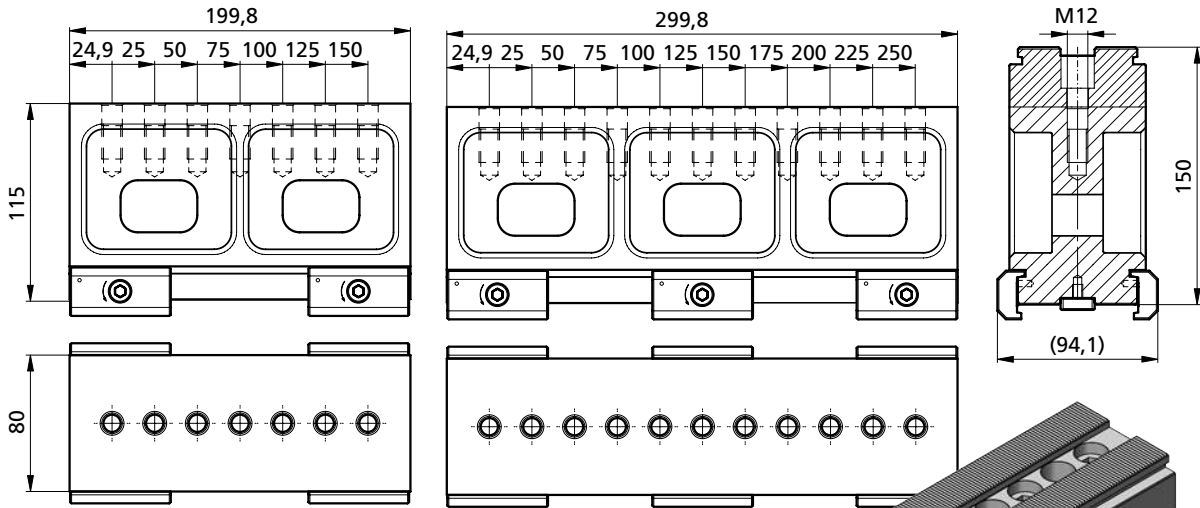

PCB25200 kg ~3,6

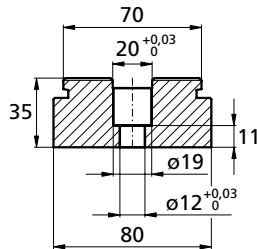
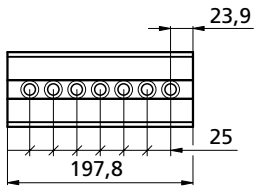

PCB25300 kg ~5,4

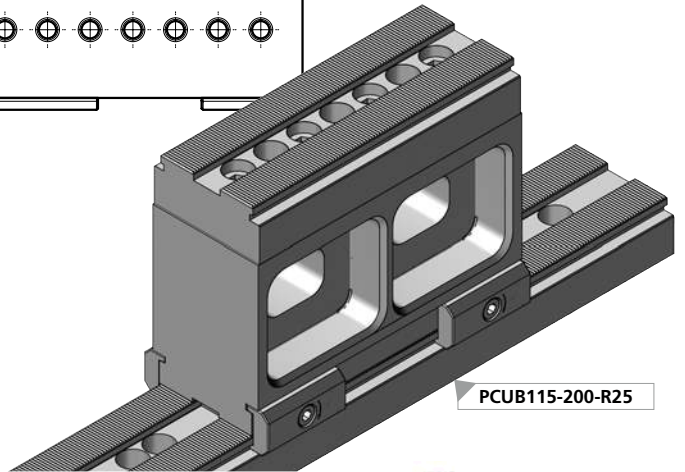
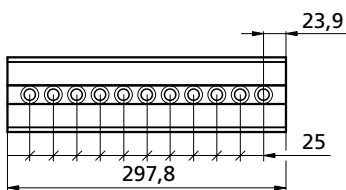

PCUB115-200-R25

PCUB115-200-R25

- 1 1x TK130323
 - 2 1x PCB25200
 - 3 2x PCSP60R
 - 4 2x PCSP60L
 - 5 2x PCS14
 - 6 2x PCGU2049
 - 7 2x M6X8ISO7380
 - 9 2x TWPAS1240
 - 10 2x M12X40ISO4762
- kg ~13

PCUB115-300-R25

- 1 1x TK130324
 - 2 1x PCB25300
 - 3 3x PCSP60R
 - 4 3x PCSP60L
 - 5 3x PCS14
 - 6 3x PCGU2049
 - 7 3x M6X8ISO7380
 - 9 2x TWPAS1240
 - 10 4x M12X40ISO4762
- kg ~19,6

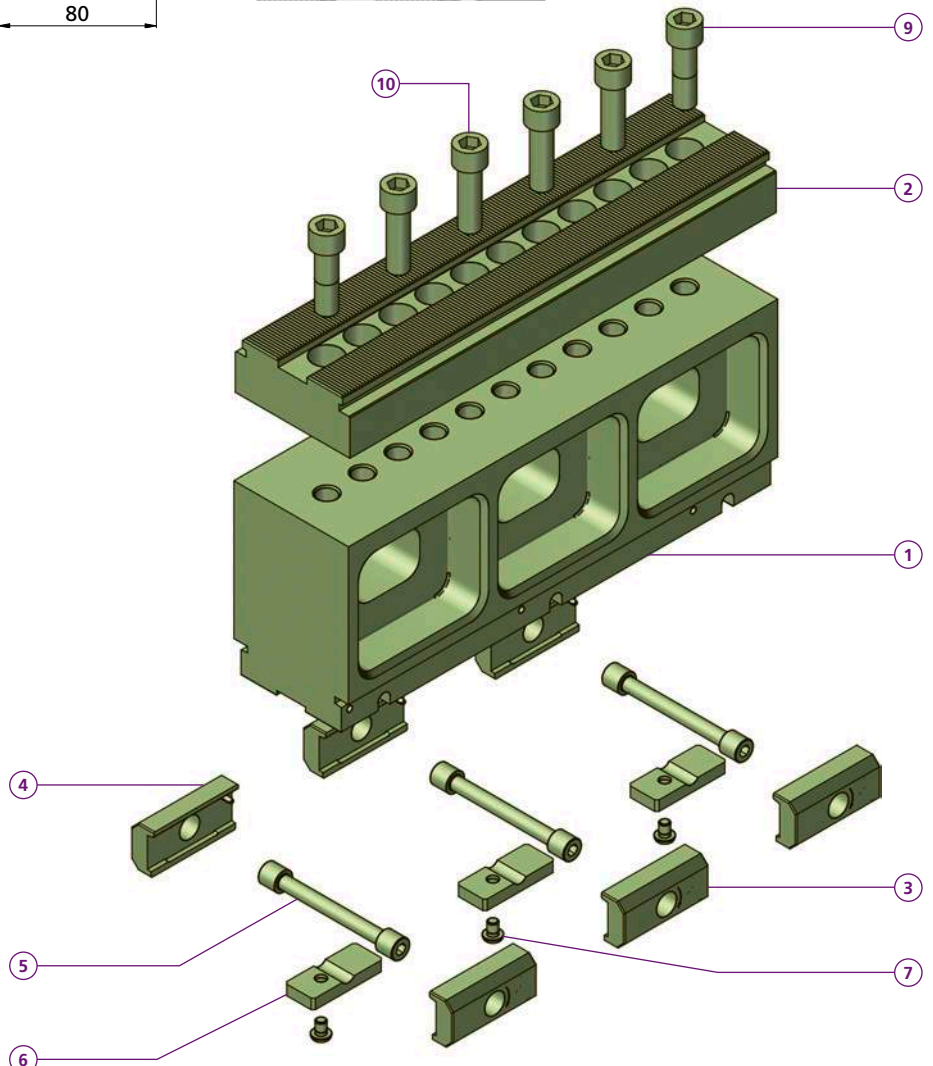

Bestellbeispiel / Ordering example: **PCUB115-300-R25**

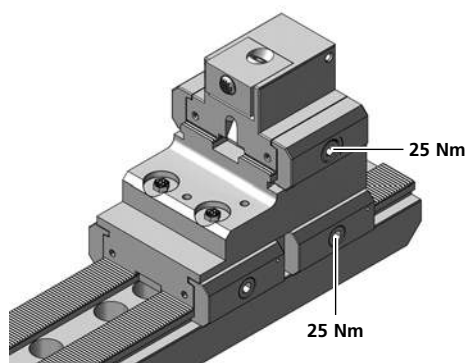
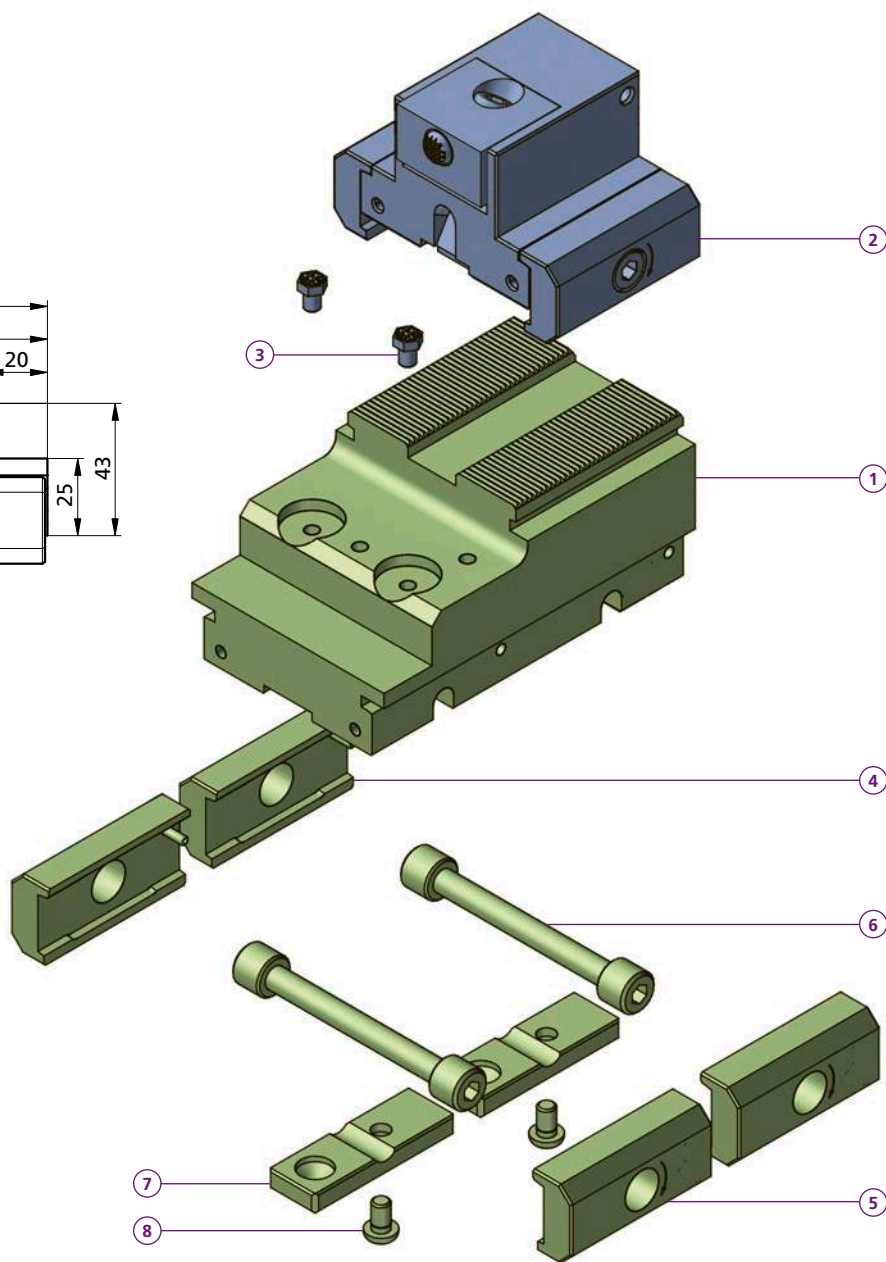
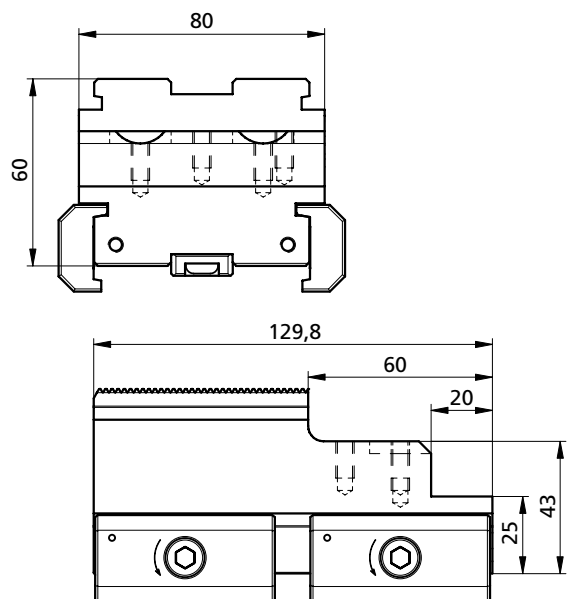

PCUB60-70-130	
①	1x TK130707
②	1x PS1F43N49-60
③	2x CCHMR
④	2x PCSP60L
⑤	2x PCSP60R
⑥	2x PCS14
⑦	2x PCGU2049
⑧	2x M6X8ISO7380
kg	~4,3

p. 64

Zubehör / Accessories p. 337

Bestellbeispiel / Ordering example: PCUB60-70-130

Separat bestellen / Order separately

Schräge Basisschiene für 5-Achsenmaschinen Slanted base rail for 5-axis machines

**5axes
powerCLAMP**

Art. Nr.	kg	∠	H
PCB50207W25	~9,2	25°	131,5
PCB50207W27	~9,5	27,5°	139,7

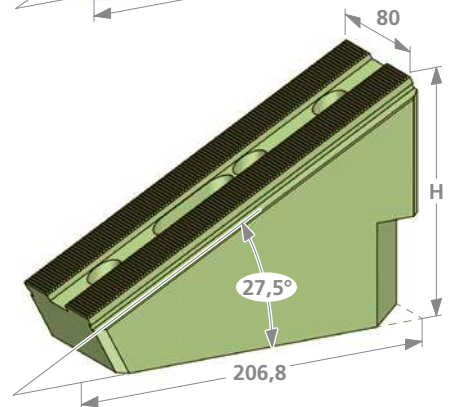
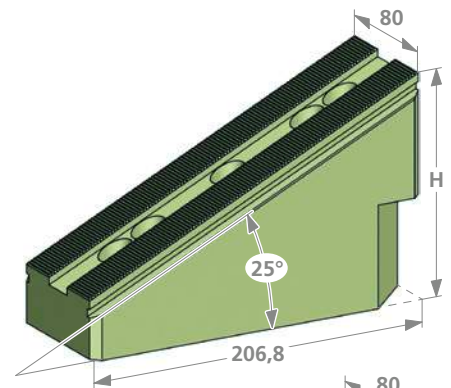
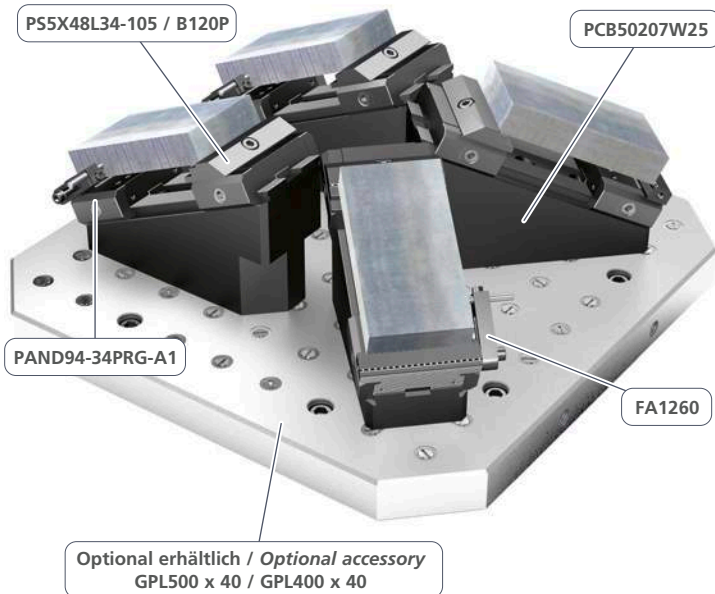

Die Basisschienen können auf einem 50 mm Raster je nach Bedarf parallel oder diagonal platziert werden.

The base rails can be placed on a 50 mm grid either parallel or diagonal as required.

Art. Nr.	kg	∠	∅	H
PCT30P-153-4	~24	60°	266	152,4

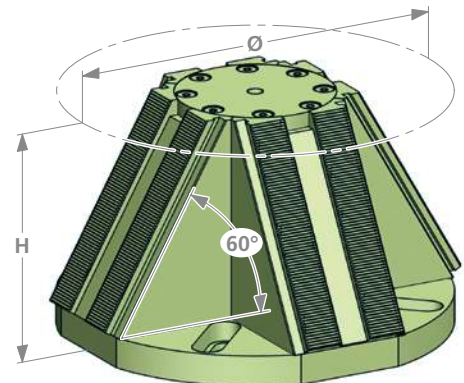
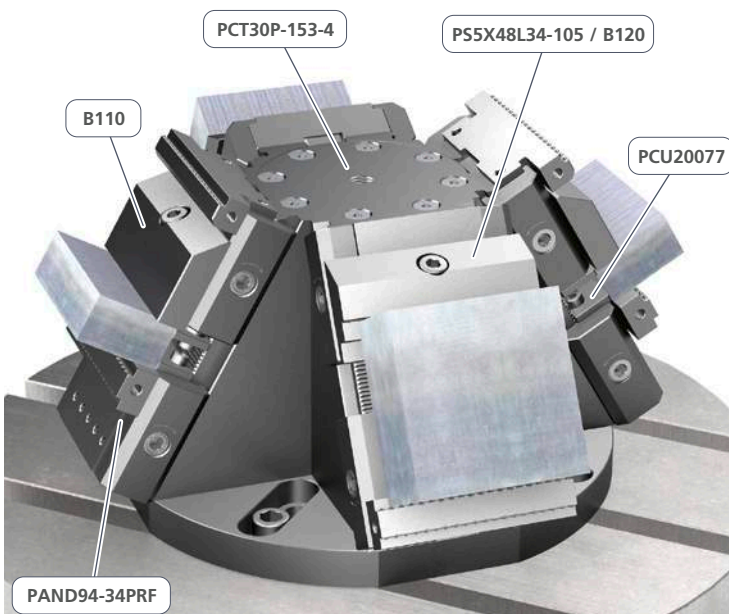

Die Stahl-Mineralgusspyramide verfügt über eine powerCLAMP Schnittstelle und ermöglicht eine kompakte und zugleich flexible 5-Achs-Bearbeitung. Die Module werden in einem Winkel von 60° montiert. Dank dem eingesetzten Mineralguss, hat die Konstruktion ein relativ tiefes Gewicht bei einer hohen Festigkeit.

The steel mineral casting pyramid has a powerCLAMP interface and enables compact and, at the same time, flexible 5-axis machining. The modules are mounted at an angle of 60°. Due to the mineral cast used, the construction has a relatively low weight with a high rigidity.

Monobloc Balken zu Teilapparat Monobloc powerCLAMP for 4th-axis

powerCLAMP

Art. Nr.	kg	L	B
PCT110-300	~24,5	300	110x110
PCT110-350	~27,5	350	110x110
PCT110-400	~31,5	400	110x110
PCT110-450	~35,5	450	110x110
PCT110-500	~39,5	500	110x110
PCT110-550	~43,0	550	110x110
PCT110-600	~47,0	600	110x110
PCT110-650	~51,0	650	110x110
PCT110-700	~55,2	700	110x110

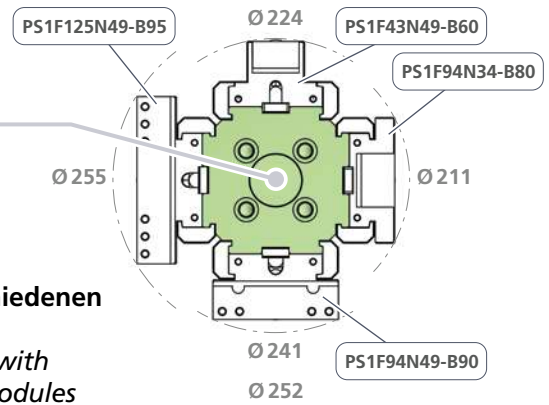
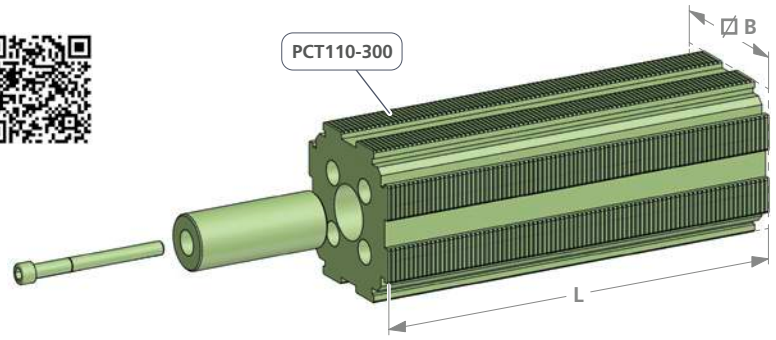

**Störkreise bei verschiedenen
Spannmodulen**
*Workpiece diameter with
different clamping modules*

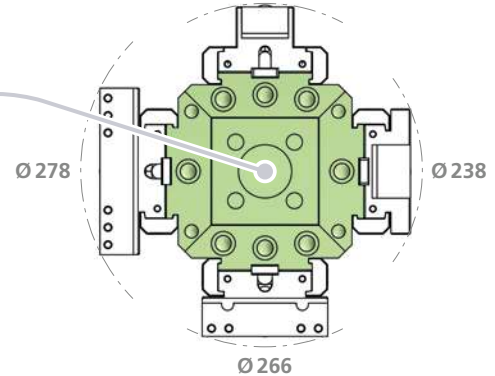

Stahl-Mineralguss
Steel-epoxy mineral

Art. Nr.	kg	L	B
PCMT150-700	~83,0	700	150x150
PCMT150-750	~89,0	750	150x150
PCMT150-800	~95,0	800	150x150
PCMT150-850	~101,0	850	150x150

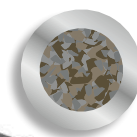

Reduziert Vibrationen und ist leicht
Reduces vibrations and is light

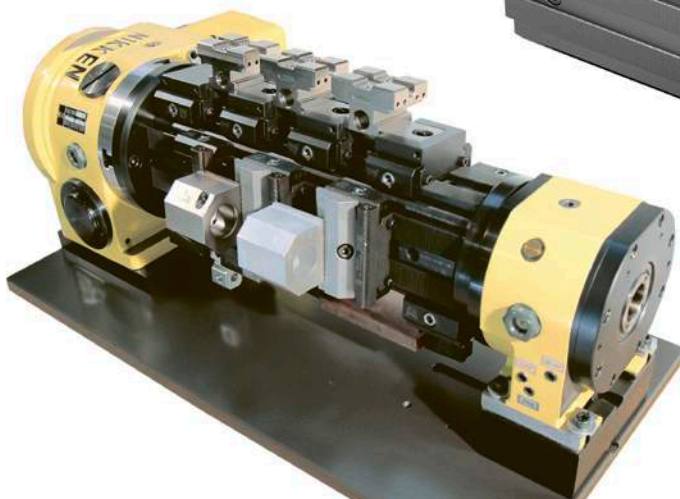

Art. Nr.	kg	H	B
PCT110-250MATS	~17	250	110x110
PCT110-300MATS	~21	300	110x110

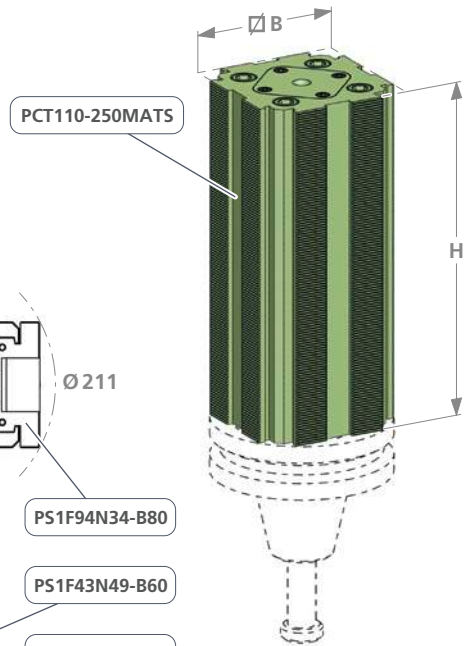

Störkreise bei verschiedenen Spannmodulen
Workpiece diameter with different clamping modules

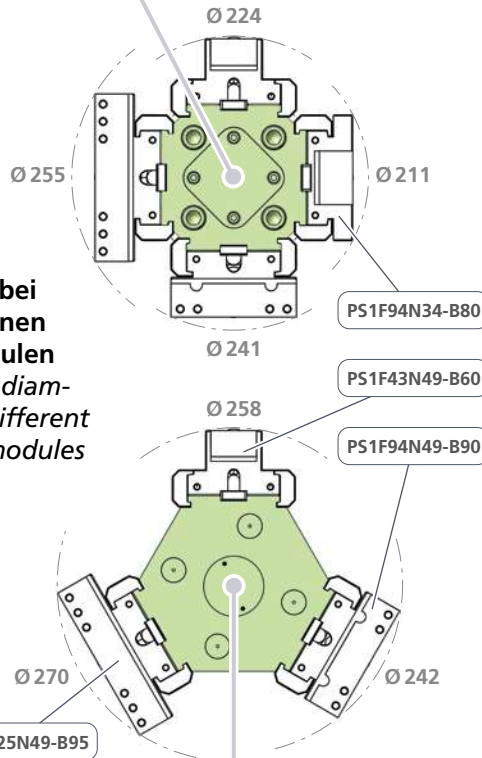

Art. Nr.	kg	H
PCT155-290-3MATS	~30	290

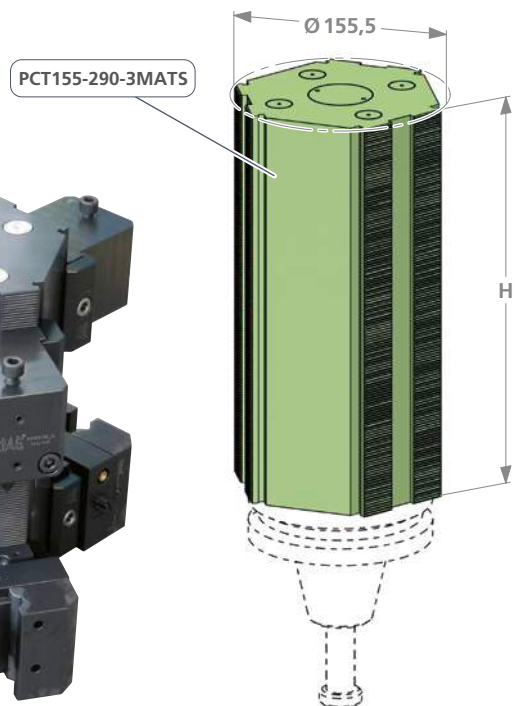

Spanntürme zu 5-Achs Bearbeitungszentren
Clamping fixtures for 5 axis machines

powerCLAMP



powerCLAMP p. 81



microCLAMP p. 178



triCENTRO p. 126

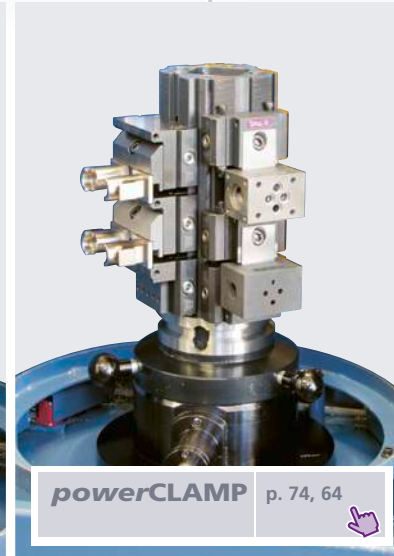

powerCLAMP p. 74, 64

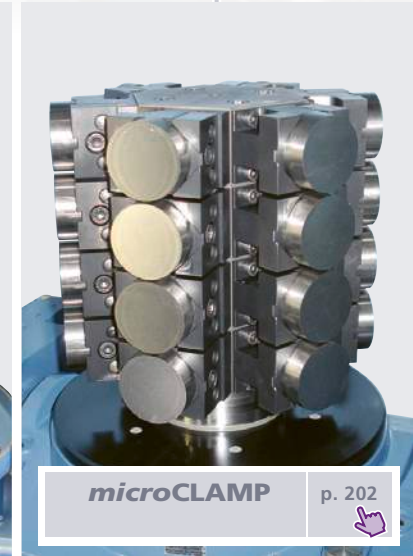

microCLAMP p. 202



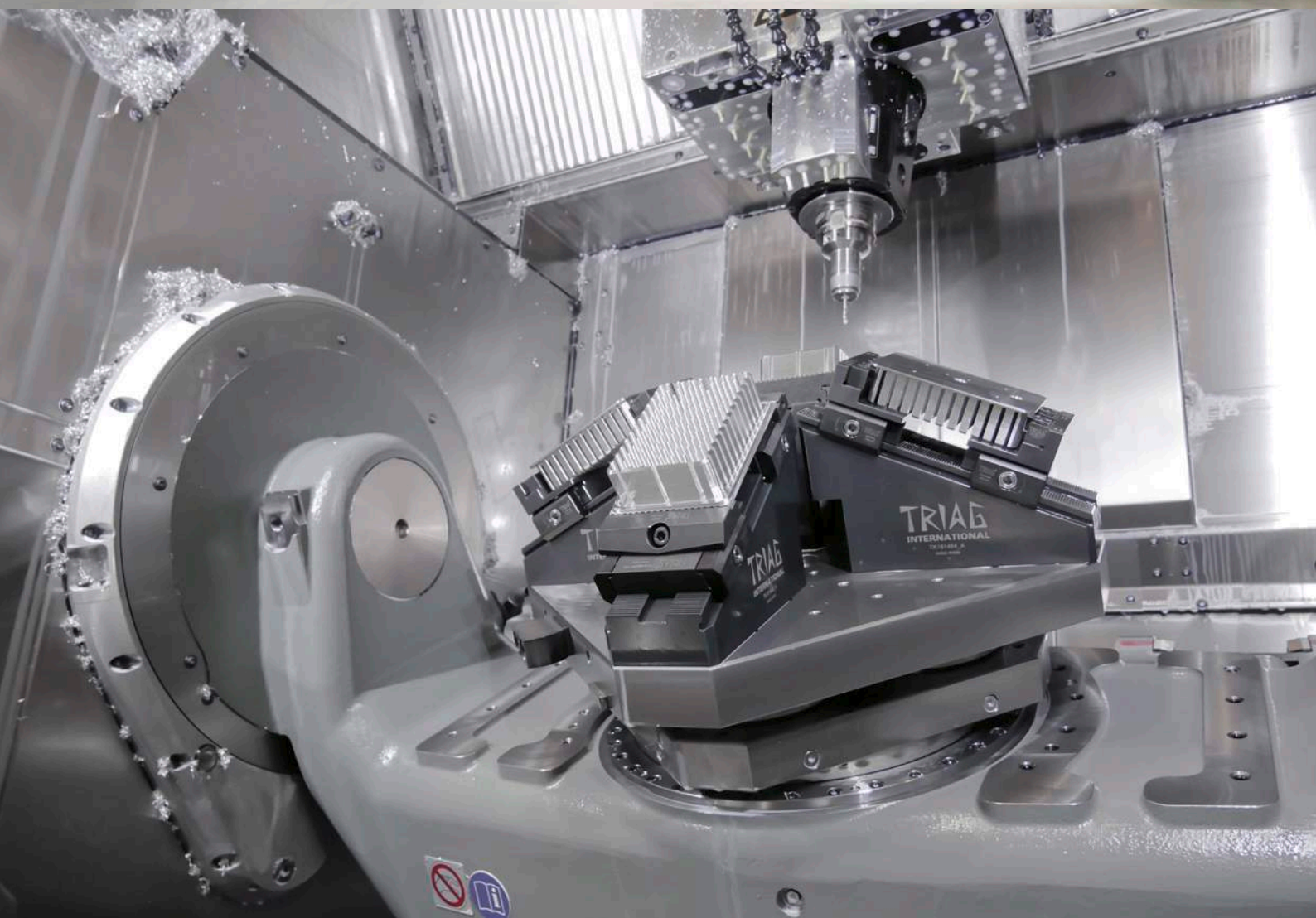

BESTELLBEISPIEL / ORDERING EXAMPLE

1x PCSET18-450A 2x PCSET18-N3 1x PS1X50N62-ER32

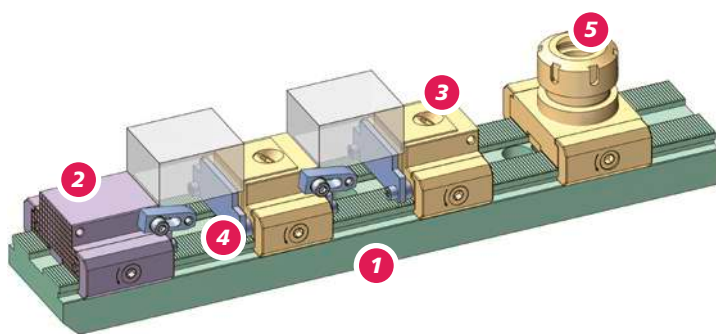
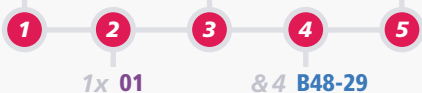

Zu jeder Basisschiene gehört 1 Anschlagmodul «Tabelle 2» nach Ihrer Wahl!
Each base rail comes with 1 end module "table 2" of your choice!

1 Basisschienen / Base-rails					
PCSET18-250A	PCB2550250	PCSET18-600A	PCB4050600		
PCSET18-350A	PCB4050350	PCSET18-650A	PCB4050650		
PCSET18-400A	PCB4050400	PCSET18-700A	PCB4050700		
PCSET18-450A	PCB4050450	PCSET18-750A	PCB4050750		
PCSET18-500A	PCB4050500	PCSET18-800A	PCB4050800		
PCSET18-550A	PCB4050550				
PCSET18-320B	PCB50-320H60				
PCSET18-400B	PCB100-400H60				
PCSET18-500B	PCB100-500H60				
PCSET18-600B	PCB100-600H60				
PCSET18-650B	PCB100-650H60				
PCSET18-690B	PCB100-690H60				
PCSET18-850B	PCB100-850H60				

2 Anschlagmodule / End modules					
48		78		94	
PAND 48-34	PAND 48-49	PAND 78-34	PAND 78-49	PAND 94-34	PAND 94-49
01	02	05	06	07	08
PAND 48-34 PRF-A1	PAND 48-49 PRF-A1	<ul style="list-style-type: none"> F = glatt / flat R = geriffelt / double serrated ☉ = Direktprägebacken / Direct stamping 		PAND 94-34 PRF-A1	PAND 94-49 PRF-A1
03	04			09	10

5 Dreibackenfutter Spannzangenmodul Mini-Zentrischspanner Three-jaw chuck Collet module Mini-self centering vise					
PS3X125L87BSET	PS3X100L82BSET	PS3X80L75BSET	PS1X50N62-ER32	PCZ80L40PRG62	PCZ100L50

3 Niederzugspannmodule / Pull down clamp modules

48		78		94	
PS1 R48N34 B80N 	PS1 R48N49 B80N 	PS1 R78N49 B90R78 	PS1 F48N49 B90F78 	PS1 R94N49 B90 	PS1 F94N49 B90
PCSET18-N1	PCSET18-N2	PCSET18-N5	PCSET18-N6	PCSET18-N7	PCSET18-N8
PS1 F48N34 B80N 	PS1 F48N49 B80N 	<p>F = glatt / flat R = geriffelt / double serrated = Direktprägebacken / Direct stamping</p>		PS1 R94N49 B93 	
PCSET18-N3	PCSET18-N4			PCSET18-N9	

Linearspannmodule / Linear clamp modules

PS1 PF 48L34 B115P 	PS1 PF 48L49 B115P 	PS1 R78L34 B141 	PS1 F78L34 B140 	PS1 PF 94L34 B120P 	PS1 PF 94L49 B120P
PCSET18-L1	PCSET18-L2	PCSET18-L5	PCSET18-L6	PCSET18-L9	PCSET18-L11
PS1 R48L49 B106 	PS1 F48L49 B105 	PS1 R78L49 B141 	PS1 F78L49 B140 	PS1 R94L34 B111 	PS1 F94L34 B110
PCSET18-L3	PCSET18-L4	PCSET18-L7	PCSET18-L8	PCSET18-L12	PCSET18-L13
PS1 R48L34 B106 	PS1 F48L34 B105 	<p>Bei jedem Niederzug und Linear Spannmodul sind 2 Parallelunterlagen nach Ihrer Wahl und 1 Fräsanschlag enthalten. Each pull-down and linear clamping module includes 2 parallels of your choice and 1 milling buffer.</p>		PS1 R94L49 B111 	PS1 F94L49 B110
PCSET18-L16	PCSET18-L17			PCSET18-L14	PCSET18-L15

4 Parallelunterlagen / Steel parallels

48	78	94
PCU29047 	PCU39077 	PCU29093
H PCU 20 047 PCU 24 047 PCU29047 PCU 31 047 PCU 34 047 PCU 39 047 PCU 44 047 PCU 46 047	H PCU 20 077 PCU 24 077 PCU 29 077 PCU 31 077 PCU 34 077 PCU39077 PCU 44 077 PCU 46 077	H PCU 14 093 PCU 20 093 PCU 24 093 PCU29093 PCU 31 093 PCU 34 093 PCU 39 093 PCU 44 093 PCU 46 093 PCU 47 093
B48- ...	B78- ...	B94- ...

Fräsanschlag / Milling buffer FA1240 1 x Inklusive / Included

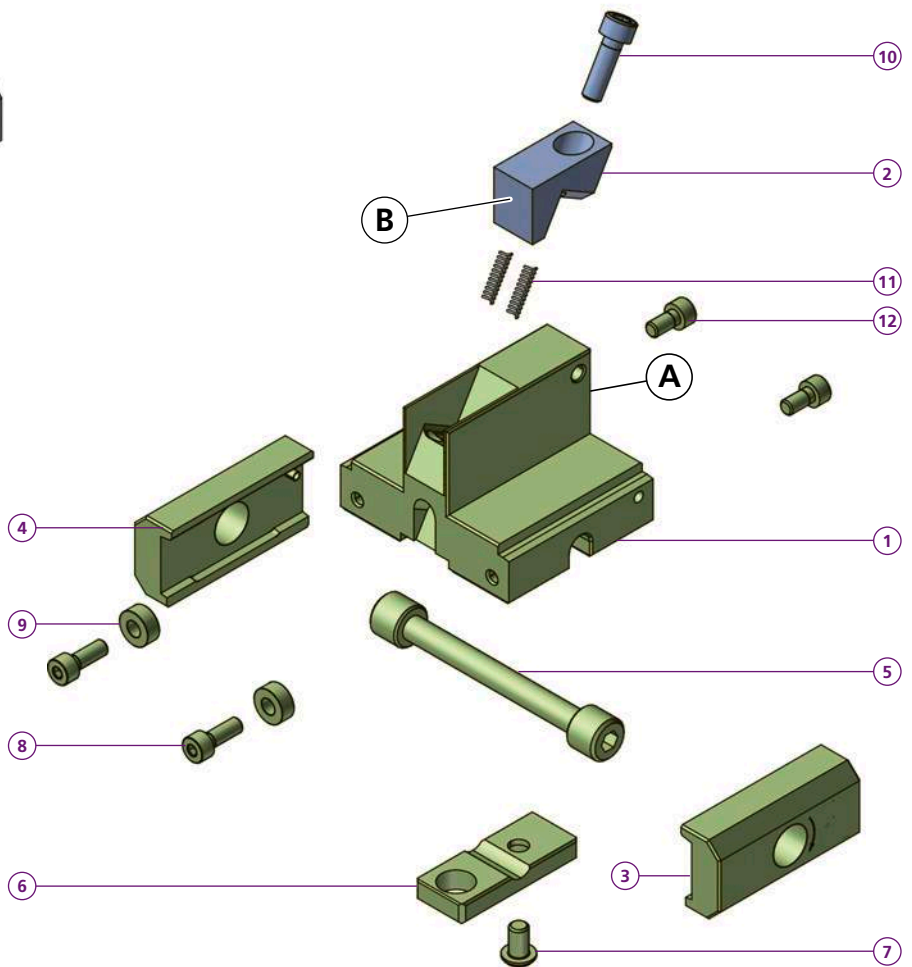
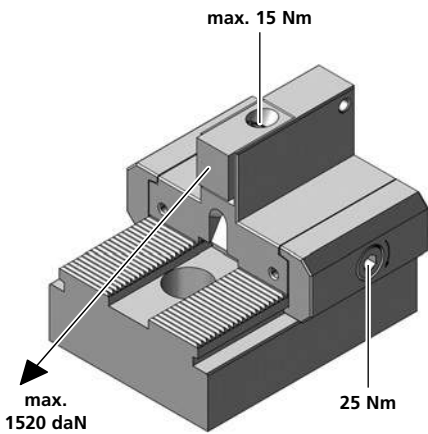
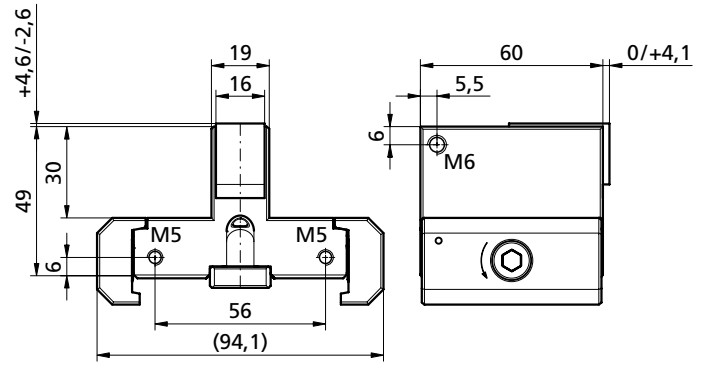
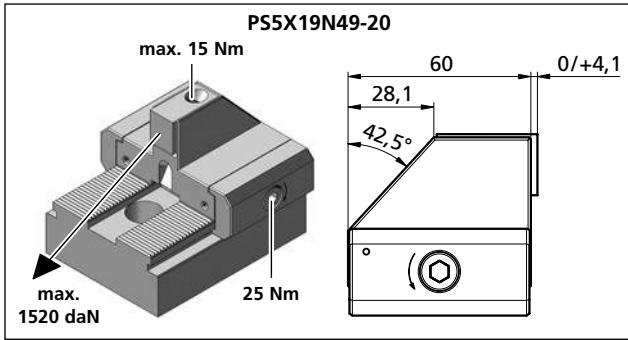

	PS5X19N49-20
1	1x TF140449
9	2x PCD005
8	2x M5X14ISO4762
kg	~1,1
	PS1F19N49-20
1	1x TF150961
	PS1R19N49-20
1	1x TF140448
2	1x
3	1x PCSP60R
4	1x PCSP60L
5	1x PCS14
6	1x PCGU2049
7	1x M6X8ISO7380
8	2x M5X14ISO4762
9	2x PCD005
10	1x M6X20ISO4762
11	2x FED0418
12	2x M5X10ISO4762
kg	~1,2

Bestellbeispiel / Ordering example: 1x PS1R19N49-20 & 1x B21

	B20	B21	B22
C	16	16	16
H	20	20	20
L	19	19	19
D	6,5	6,5	6,5
ø	12	12	12
i	HV700	HV700	*
	x0,2mm	x0,2mm	
kg	~0,06	~0,06	~0,06

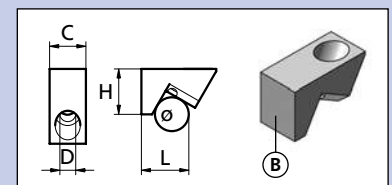

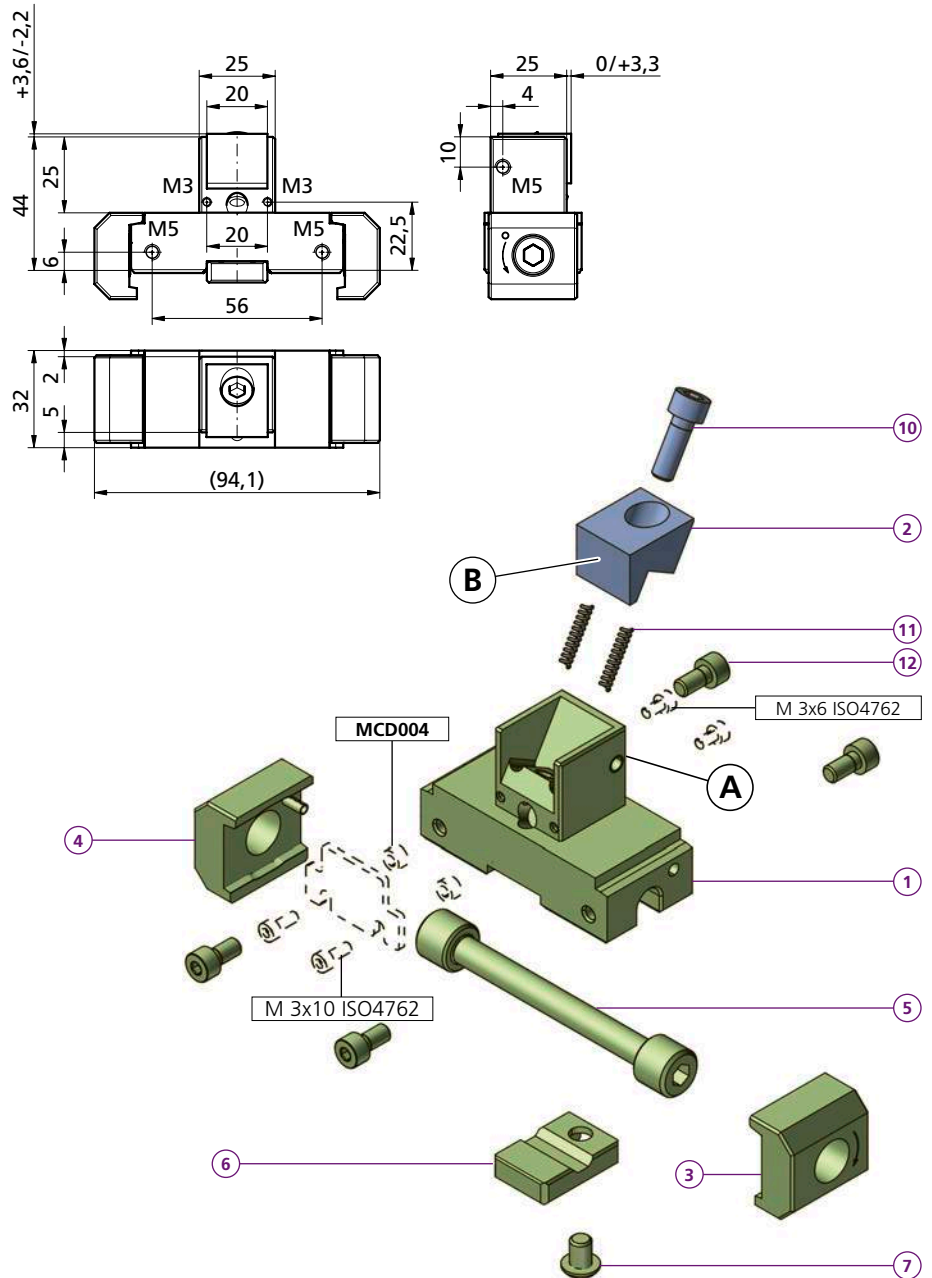
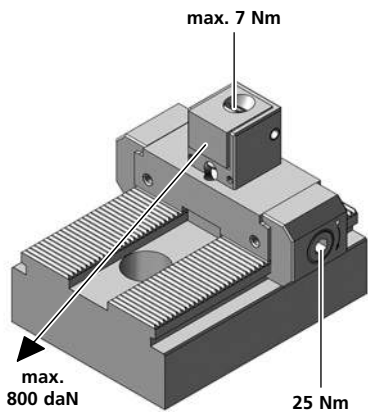

PS1F25N44-13	
1	1x TF150960
PS1R25N44-13	
1	1x TF140450
2	1x
3	1x PCSP30R
4	1x PCSP30L
5	1x PCS14
6	1x PCGU2030
7	1x M6X8ISO7380
10	1x M6X16ISO4762
11	2x FED03018
12	4x M5X10ISO4762
kg	~0,6

Bestellbeispiel / Ordering example: 1x PS1R25N44-13 & 1x B14				
	B13	B14	B15	B16
C	20	20	20	20
H	16	16	16	16
L	13,8	13,8	13,8	19
D	6,5	6,5	6,5	6,5
e	10	10	10	10
i	HV700	HV700	*	*
	x0,2mm	x0,2mm		
kg	~0,05	~0,05	~0,05	~0,06

	H	B	N	kg
MCU11037	11	23	2	~0,004
MCU15037	15	23	2	~0,006
MCU18037	18	23	2	~0,008
MCU20037	20	23	2	~0,008
MCU22537	22,5	23	2	~0,008

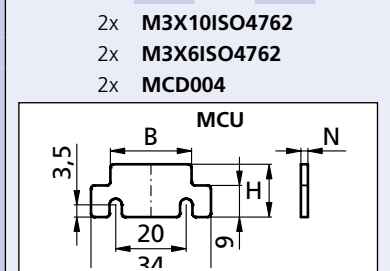

2x	M3X10ISO4762
2x	M3X6ISO4762
2x	MCD004

* = weicher Stahl / soft steel

PS1R/F26N49-26

PS5X26N49-26

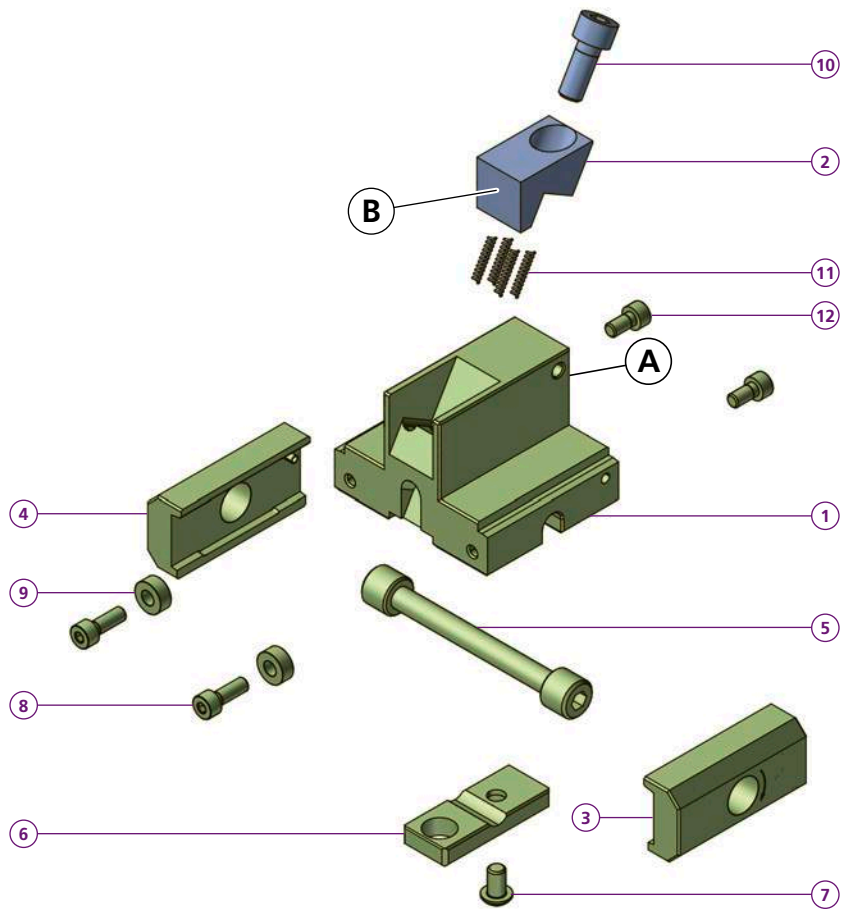
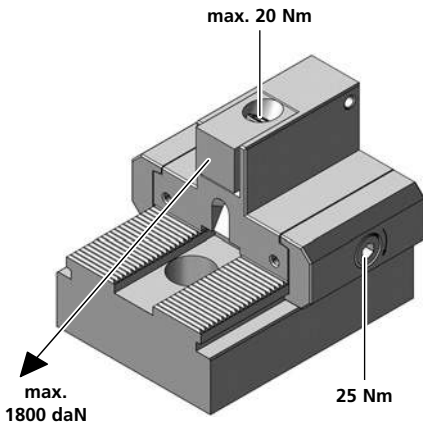
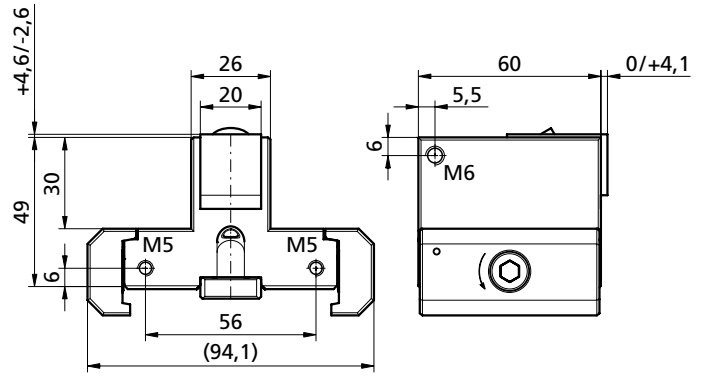
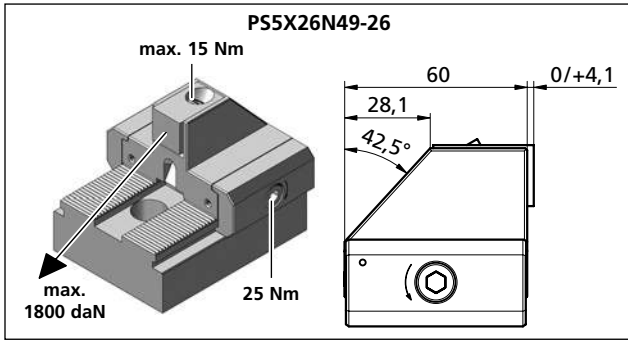

PS5X26N49-26	
1	1x TF140453
9	2x PCD005
8	2x M5X14ISO4762
kg	~1,1
PS1F26N49-26	
1	1x TF140451
PS1R26N49-26	
1	1x TF140452
2	1x
3	1x PCSP60R
4	1x PCSP60L
5	1x PCS14
6	1x PCGU2049
7	1x M6X8ISO7380
8	2x M5X14ISO4762
9	2x PCD005
10	1x M8X20ISO4762
11	4x FED0418
12	2x M5X10ISO4762
kg	~1,2

B	B26	B27	B28
C	20	20	20
H	20	20	20
L	19	19	19
D	9	9	9
e	12	12	12
i	HV700	HV700	*
	x0,2mm	x0,2mm	
kg	~0,07	~0,07	~0,07

Bestellbeispiel / Ordering example: 1x PS1R26N49-26 & 1x B26

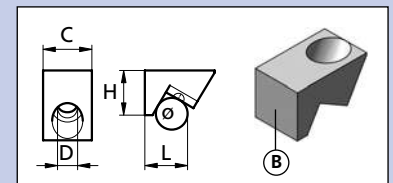

Separat bestellen / Order separately

PS1R/F34N49-45

PS5X34N49-45

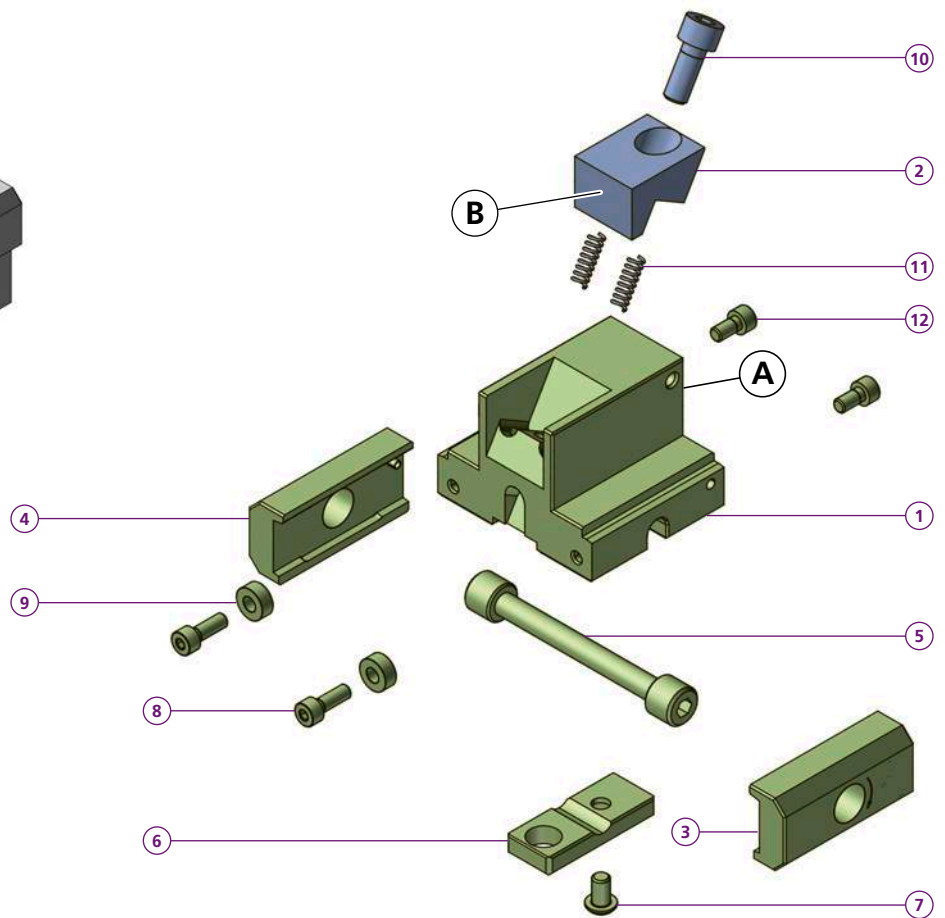
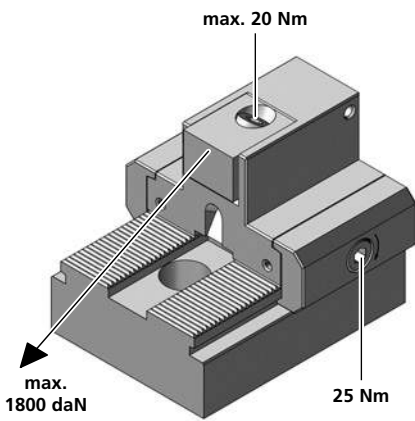
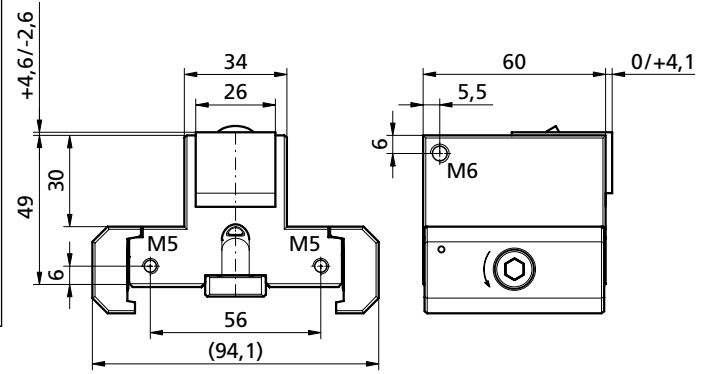
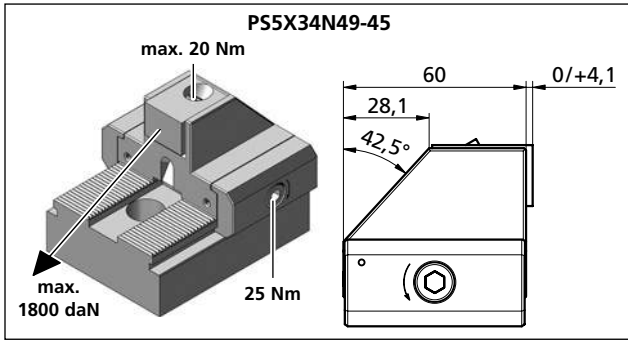

A	PS5X34N49-45
1	1x TF140455
9	2x PCD005
8	2x M5X14ISO4762
kg	~1,2
	PS1F34N49-45
1	1x TF191071
	PS1R34N49-45
1	1x TF140454
2	1x
3	1x PCSP60R
4	1x PCSP60L
5	1x PCS14
6	1x PCGU2049
7	1x M6X8ISO7380
8	2x M5X14ISO4762
9	2x PCD005
10	1x M8X20ISO4762
11	2x FED0618
12	2x M5X10ISO4762
kg	~1,3

Bestellbeispiel / Ordering example: 1x **PS5X34N49-45** & 1x **B47HM**

	B45	B46	B47	B47HM
C	26	26	26	26
H	20	20	20	20
L	19	19	19,1	19,1
D	9	9	9	9
e	12	12	12	12
i	HV700 x0,2mm	HV700 x0,2mm	*	HM
kg	~0,1	~0,1	~0,1	~0,1

* = weicher Stahl / soft steel

HM = Hartmetallbeschichtet / Carbide coated

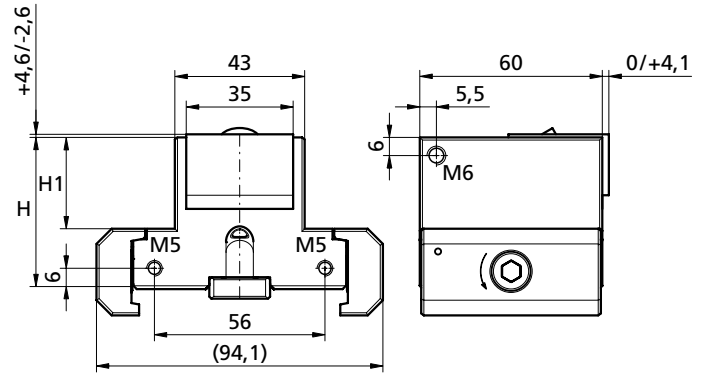
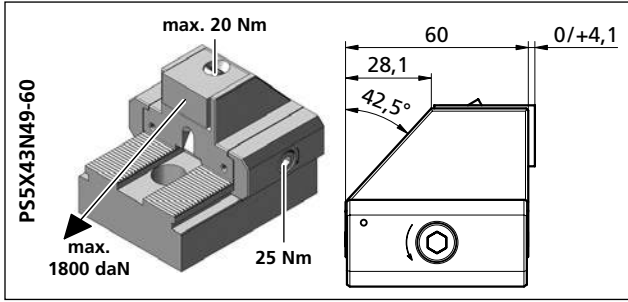

- PS5X43N49-60**
- 1x TF140458
 - 2x PCD005
 - 2x M5X14ISO4762
- kg ~1,3
- PS1F43N49-60**
- 1x TF140456
- PS1R43N49-60**
- 1x TF140457
 - 1x PCSP60R
 - 1x PCSP60L
 - 1x PCS14
 - 1x PCGU2049
 - 1x M6X8ISO7380
 - 2x M5X14ISO4762
 - 2x PCD005
 - 1x M8X20ISO4762
 - 2x FED0618
 - 2x M5X10ISO4762
- H = 49
H1 = 30
kg ~1,4
- PS1F43N62-60**
- 1x TF140459
- PS1R43N62-60**
- 1x TF140460
- H = 62
H1 = 43
kg ~1,7

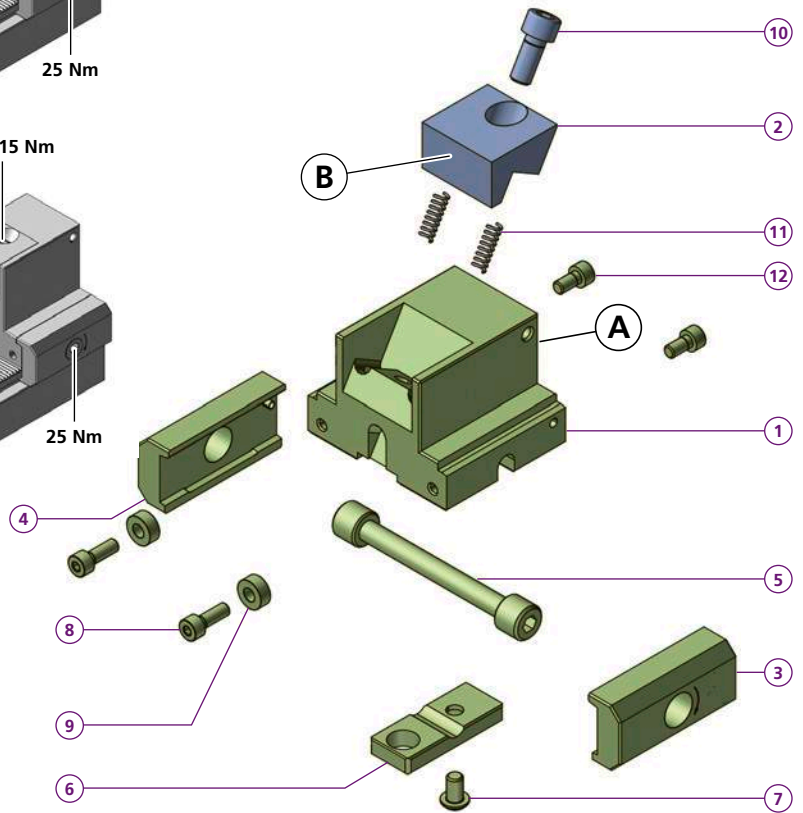
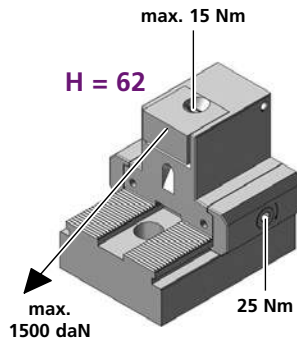
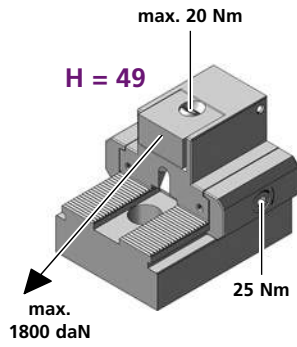

Bestellbeispiel / Ordering example: 1x PS1R43N49-60 & 1x B61

	B58	B60	B61	B62	B62HM	B65	B66	B67	B68	B69	B77	B79F	B79R
C	35	35	35	35	35	35	35	35	35	35	35	35	35
H	20	20	20	20	20	20	20	20	20	25	20	20	20
L	26	19	19	19	19	19	19	24	26	22	22	25	25
D	9	9	9	9	9	9	9	9	9	9	9	9	9
o	12	12	12	12	12	12	12	12	12	12	12	12	12
i	ALU	56HRC	56HRC	*	HM	HV700 x0,2mm	HV700 x0,2mm	HV700 x0,2mm	*	*	56HRC	HV700 x0,2mm	HV700 x0,2mm
kg	~0,07	~0,12	~0,12	~0,12	~0,12	~0,12	~0,12	~0,14	~0,15	~0,15	~0,12	~0,18	~0,18

B69
M5X10ISO4762
+11,5/-0,7
0/+7

FED 0628

B58

B60, B61, B62, B62HM

B65, B66, B67

B68

B77

B79F, B79R

Separat bestellen / Order separately

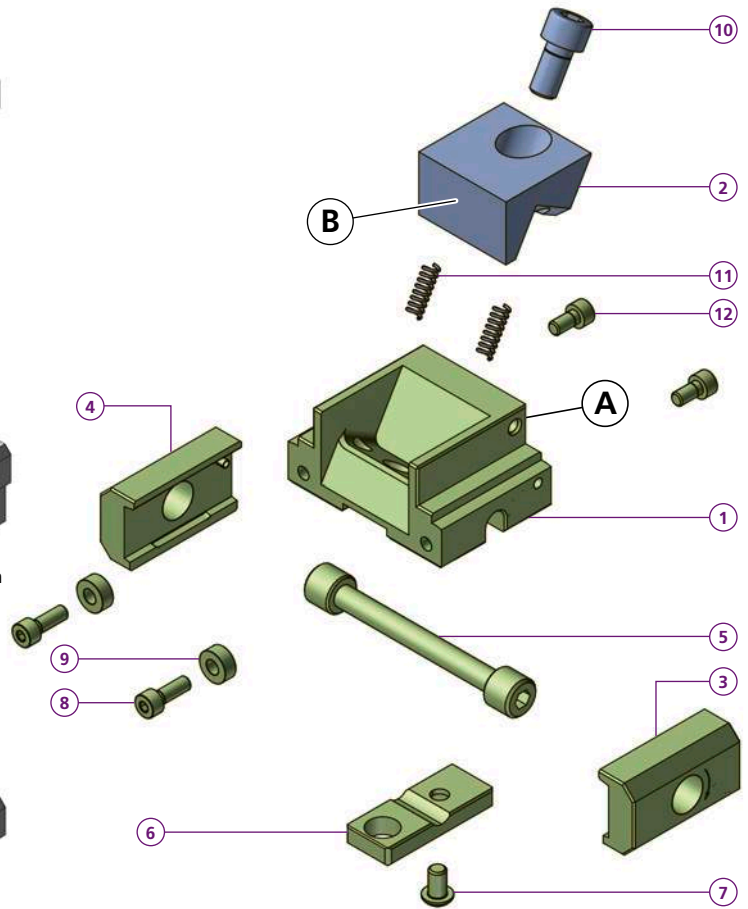
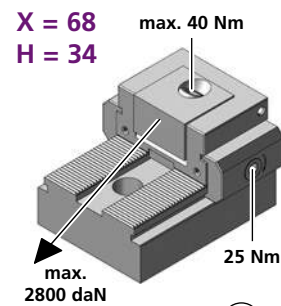
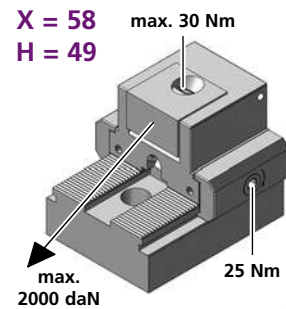
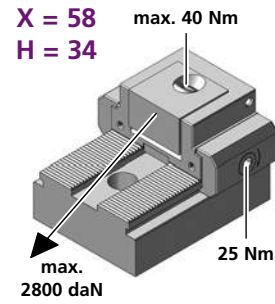
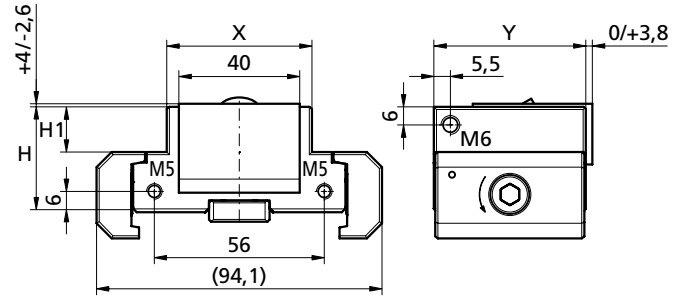
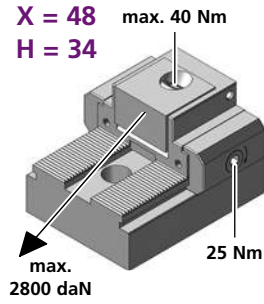

PS1F48N34-80

- 1 1x TF140461
- PS1R48N34-80**
- 1 1x TF140462
 - 2 1x
 - 3 1x PCSP50R
 - 4 1x PCSP50L
 - 5 1x PCS14
 - 6 1x PCGU2049
 - 7 1x M6X8ISO7380
 - 8 2x M5X14ISO4762
 - 9 2x PCD005
 - 10 1x M10X25ISO4762
 - 11 2x FED0618
 - 12 2x M5X10ISO4762
- X = 48
H = 34
H1 = 15
Y = 50
kg ~0,9

PS1F58N34-80

- 1 1x TF140463
- PS1R58N34-80**
- 1 1x TF140464
- X = 58
H = 34
H1 = 15
Y = 50
kg ~0,9

PS1R58N49-80

- 1 1x TK120129
 - 3 1x PCSP60R
 - 4 1x PCSP60L
- X = 58
H = 49
H1 = 30
Y = 60
kg ~1,6

PS1F68N34-80

- 1 1x TF140465
- PS1R68N34-80**
- 1 1x TF140466
- X = 68
H = 34
H1 = 15
Y = 50
kg ~1,0

Bestellbeispiel / Ordering example: 1x PS1F68N34-80 & 1x B82HM

	B80	B80N	B81	B82	B82L33	B82HM	B83	B84	B89F	B89R
C	40	40	40	40	40	40	40	40	40	40
H	25	25	25	25	25	25	25	25	25	25
L	22	22	22	22,2	33	22,2	22	26,3	29	29
D	11	11	11	11	11	11	11	11	11	11
e	15	15	15	15	15	15	15	15	15	15
i	56HRC	HV700 x0,2mm	56HRC	*	*	56HRC	HV700 x0,2mm	*	HV700 x0,2mm	HV700 x0,2mm
kg	~0,2	~0,2	~0,2	~0,2	~0,28	~0,2	~0,2	~0,2	~0,24	~0,24

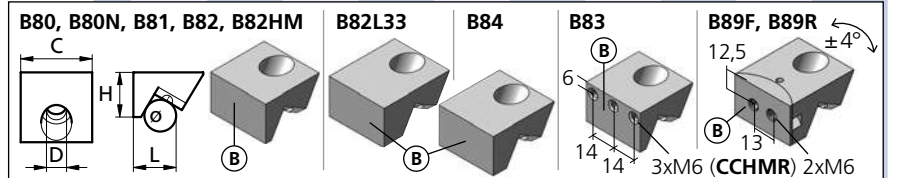

* = weicher Stahl / soft steel

HM = Hartmetallbeschichtet / Carbide coated

Separat bestellen / Order separately

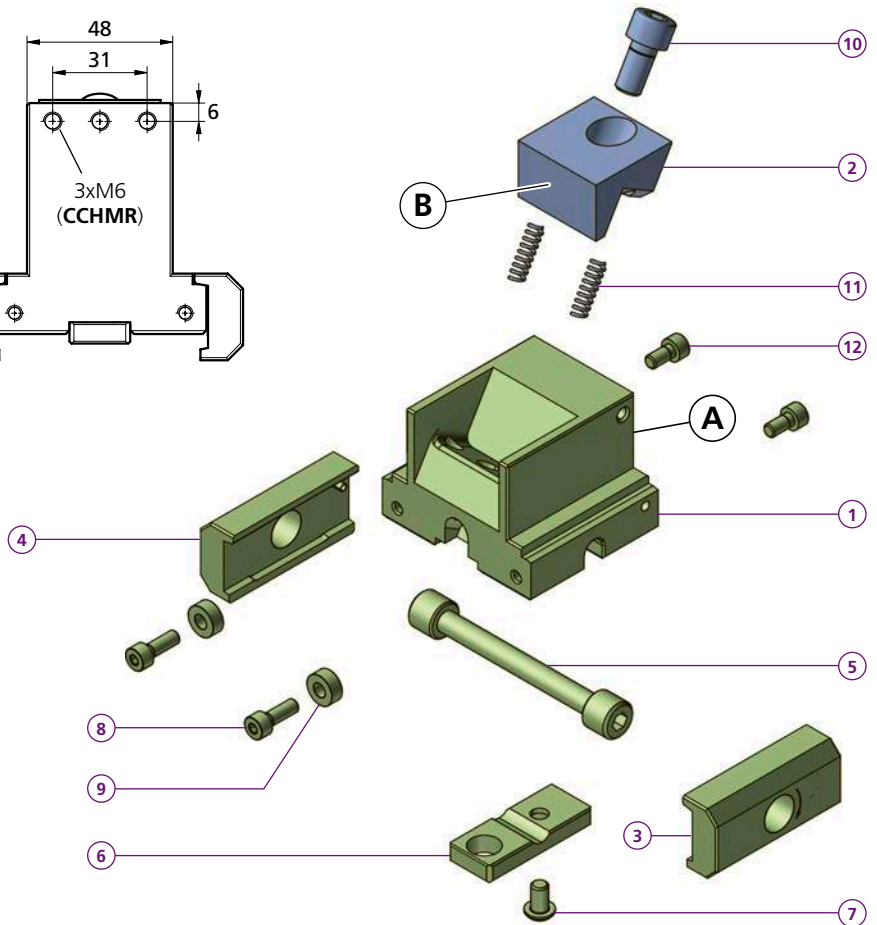
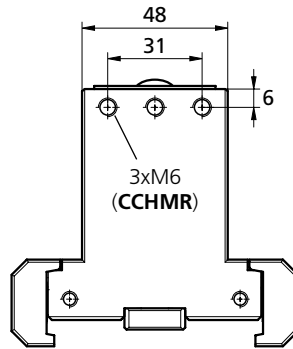
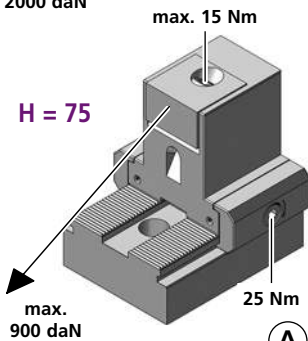
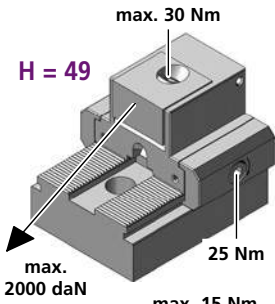
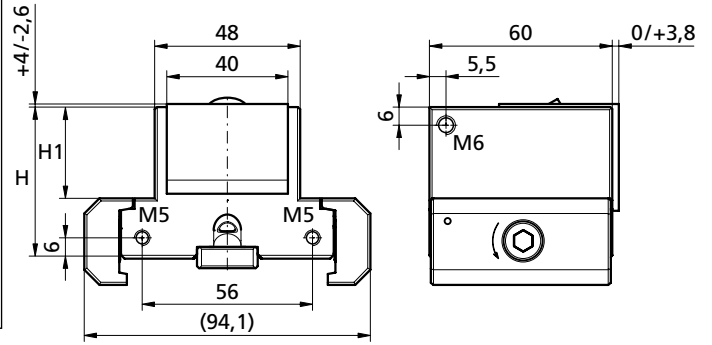
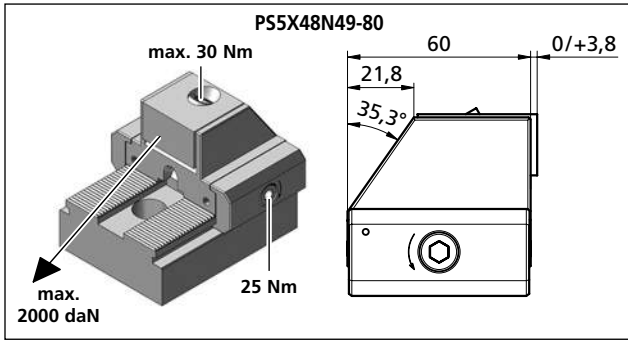

PS5X48N49-80
1x TF140469
2x PCD005
2x M5X14ISO4762
kg ~1,3
PS1F48N49-80
1x TF140467
PS1R48N49-80
1x TF140468
1x [Symbol]
1x PCSP60R
1x PCSP60L
1x PCS14
1x PCGU2049
1x M6X8ISO7380
2x M5X14ISO4762
2x PCD005
1x M10X25ISO4762
2x FED0618
2x M5X10ISO4762
H = 49
H1 = 30
kg ~1,4

PS1R48N75-80
1x TF140471
H = 75
H1 = 56
kg ~2,0

Bestellbeispiel / Ordering example: 1x PS1F48N49-80 & 1x B80

	B80	B80N	B81	B82	B82L33	B82HM	B83	B84	B89F	B89R
C	40	40	40	40	40	40	40	40	40	40
H	25	25	25	25	25	25	25	25	25	25
L	22	22	22	22,2	33	22,2	22	26,3	29	29
D	11	11	11	11	11	11	11	11	11	11
ø	15	15	15	15	15	15	15	15	15	15
i	56HRC	HV700 x0,2mm	56HRC	*	*	56HRC	HV700 x0,2mm	*	HV700 x0,2mm	HV700 x0,2mm
kg	~0,2	~0,2	~0,2	~0,2	~0,28	~0,2	~0,2	~0,2	~0,24	~0,24

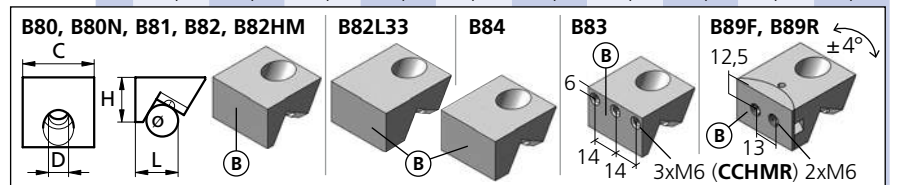

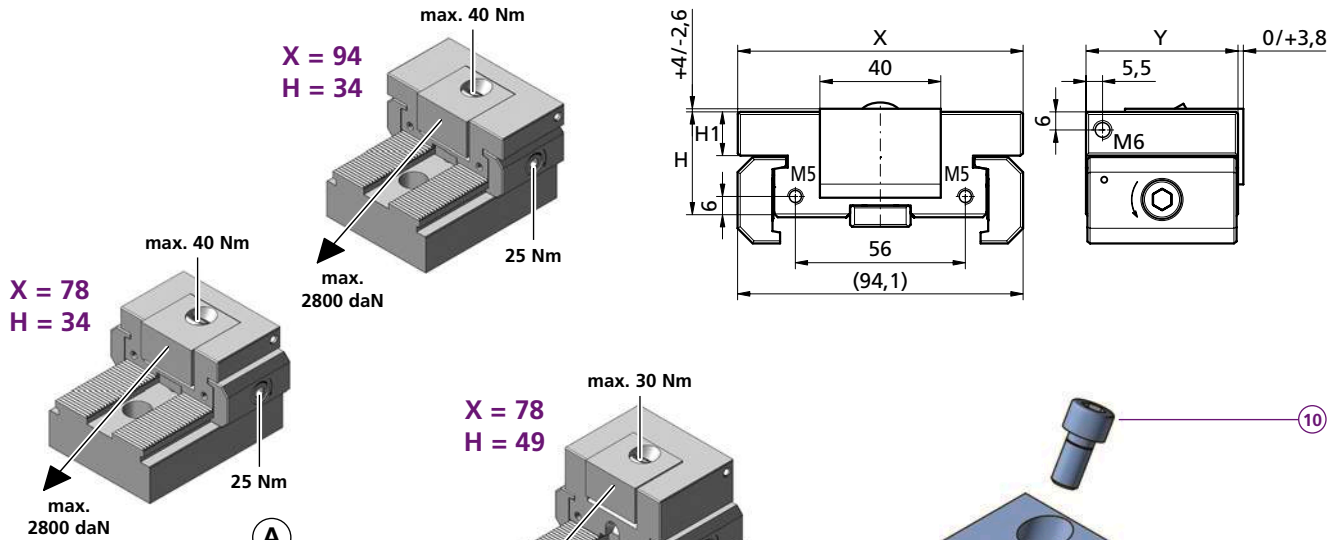

- PS1F78N34-80**
- 1 1x TF140472
- PS1R78N34-80**
- 1 1x TF140473
 - 2 1x [Material Icon]
 - 3 1x PCSP50R
 - 4 1x PCSP50L
 - 5 1x PCS14
 - 6 1x PCGU2049
 - 7 1x M6X8ISO7380
 - 8 2x M5X14ISO4762
 - 9 2x PCD005
 - 10 1x M10X25ISO4762
 - 11 2x FED0618
 - 12 2x M5X10ISO4762
- X = 48
H = 34
H1 = 15
Y = 50
kg ~1,1

- PS1F94N34-80**
- 1 1x TF140476
- PS1R94N34-80**
- 1 1x TF140477
- X = 94
H = 34
H1 = 15
Y = 50
kg ~1,1

- PS1F78N49-80**
- 1 1x TF140474
- PS1R78N49-80**
- 1 1x TF140475
 - 3 1x PCSP60R
 - 4 1x PCSP60L
- X = 78
H = 49
H1 = 30
Y = 60
kg ~1,8

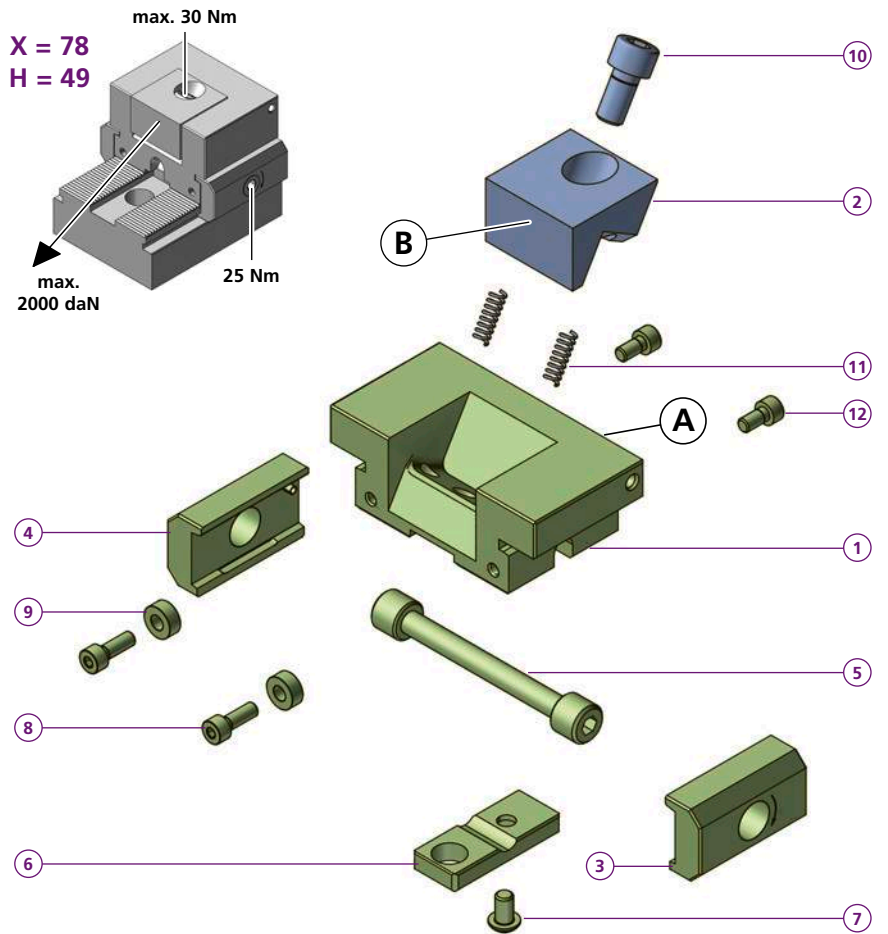

Bestellbeispiel / Ordering example: 1x PS1R94N34-80 & 1x B80

	B80	B80N	B81	B82	B82L33	B82HM	B83	B84	B89F	B89R
C	40	40	40	40	40	40	40	40	40	40
H	25	25	25	25	25	25	25	25	25	25
L	22	22	22	22,2	33	22,2	22	26,3	29	29
D	11	11	11	11	11	11	11	11	11	11
ø	15	15	15	15	15	15	15	15	15	15
i	56HRC	HV700 x0,2mm	56HRC	*	*	56HRC	HV700 x0,2mm	*	HV700 x0,2mm	HV700 x0,2mm
kg	~0,2	~0,2	~0,2	~0,2	~0,28	~0,2	~0,2	~0,2	~0,24	~0,24

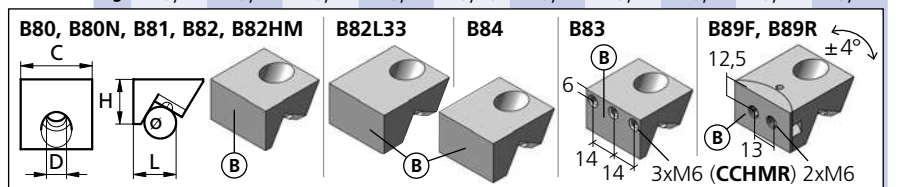

* = weicher Stahl / soft steel

HM = Hartmetallbeschichtet / Carbide coated

Separat bestellen / Order separately

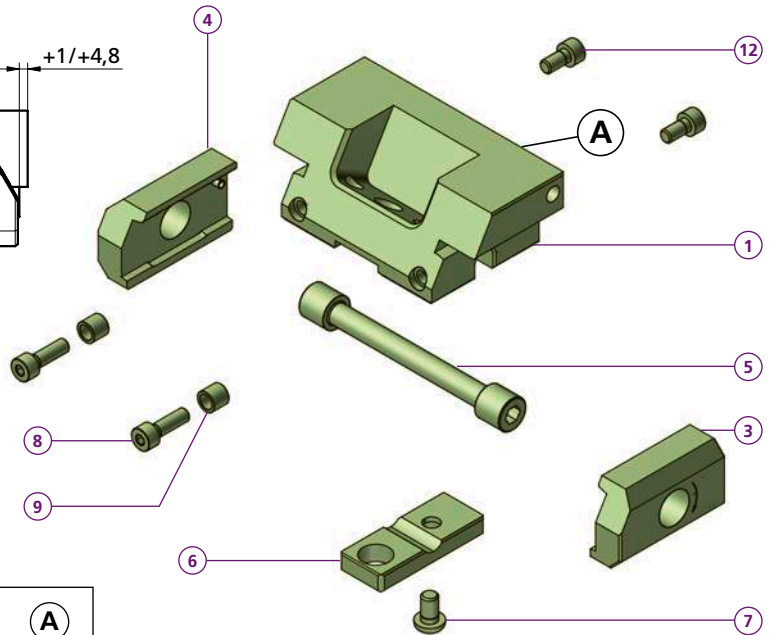
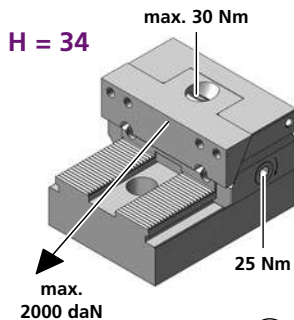
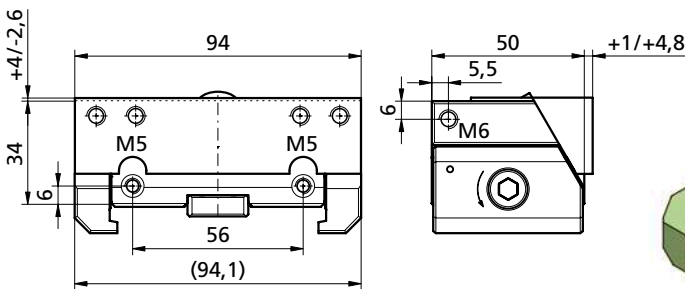
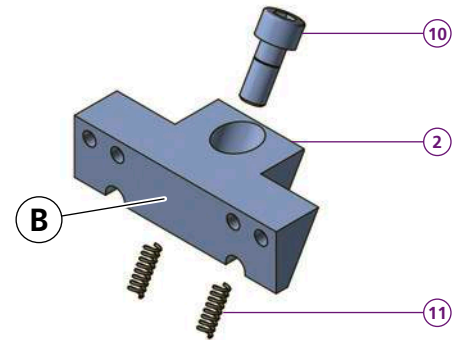
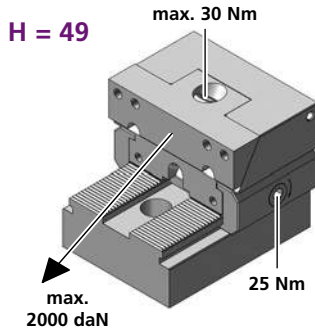
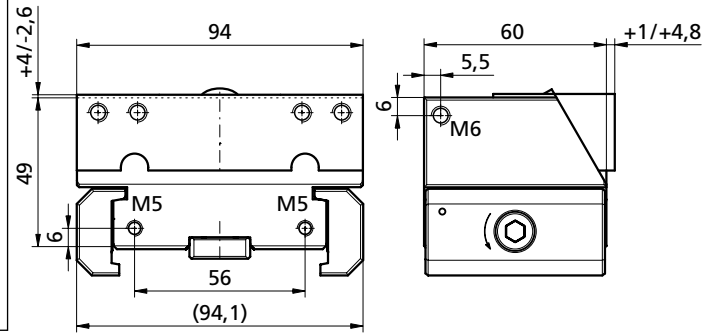
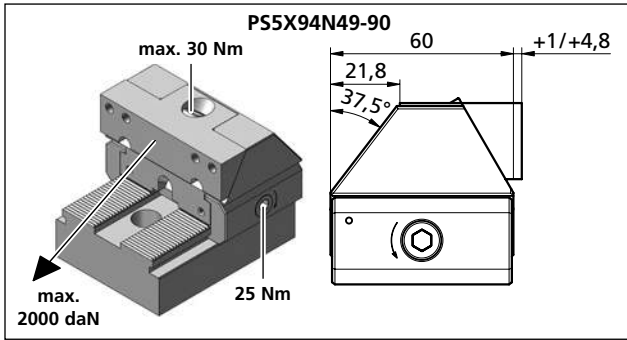

PS1F94N34-90		PS1F94N49-90	
1	1x TF140478	1	1x TF140480
2	1x _____	2	1x _____
3	1x PCSP50RF	3	1x PCSP60R
4	1x PCSP50LF	4	1x PCSP60L
5	1x PCS14	8	2x M5X14ISO4762
6	1x PCGU2049	9	2x PCD005
7	1x M6X8ISO7380		
8	2x M5X16ISO4762		
9	2x PCD008		
10	1x M10X25ISO4762		
11	2x FED0618		
12	2x M5X10ISO4762		
H	= 34	H	= 49
kg	~1,0	kg	~2,0

Bestellbeispiel / Ordering example:
1x PS1F94N34-90 & 1x B91

	B90	B91	B92	B93	B94
C	94	94	94	94	94
H	25	25	25	25	25
L	23	23	23	23	40
D	11	11	11	11	11
e	15	15	15	15	15
i	HV700 x0,2mm	HV700 x0,2mm	*	HV700 x0,2mm	*
kg	~0,33	~0,33	~0,33	~0,33	~0,64

Separat bestellen / Order separately

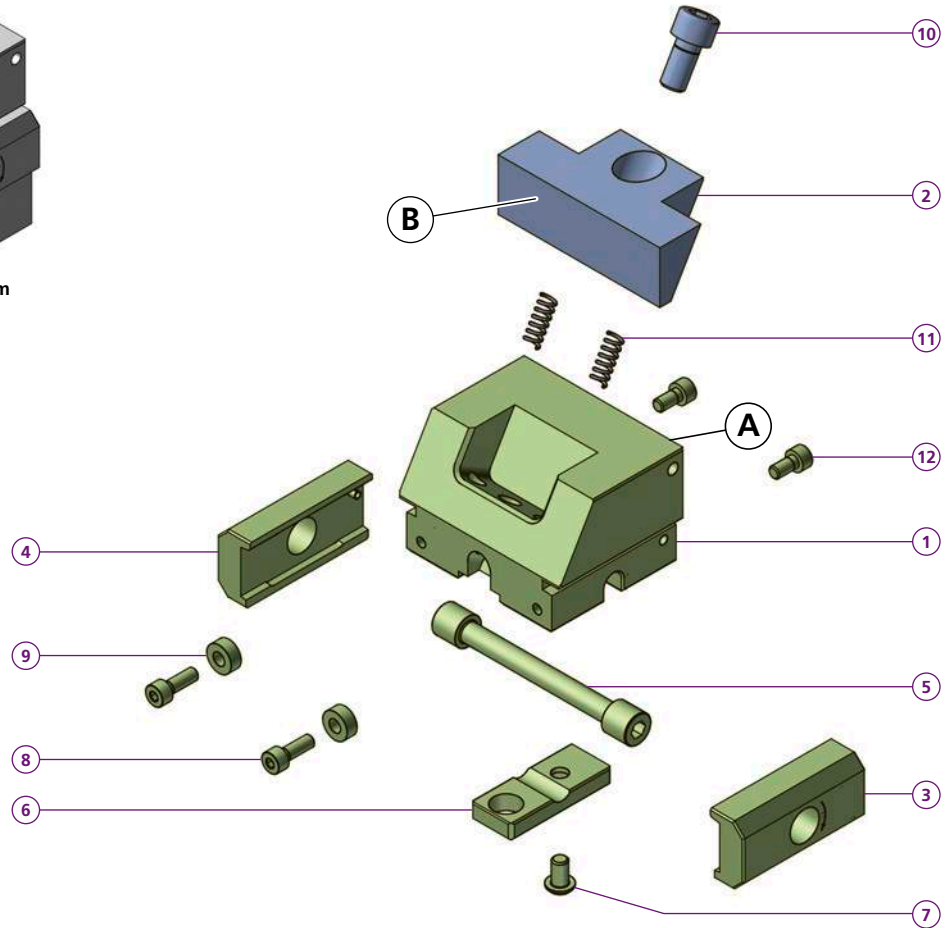
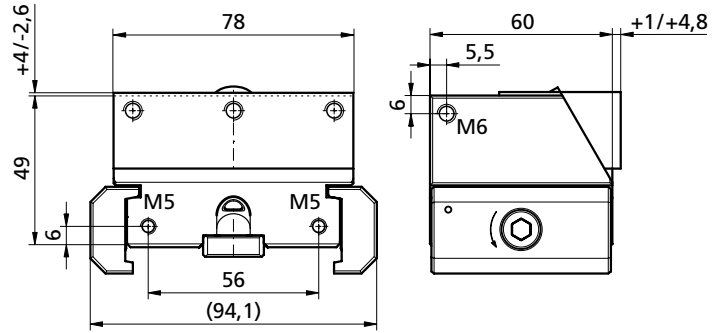
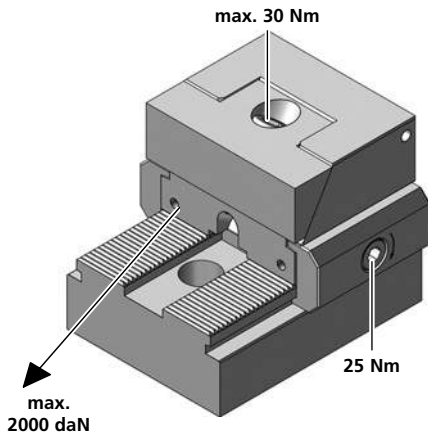

PS1F78N49-90	
1	1x TH160490
PS1R78N49-90	
1	1x TH160490
2	1x
3	1x PCSP60R
4	1x PCSP60L
5	1x PCS14
6	1x PCGU2049
7	1x M6X8ISO7380
8	2x M5X14ISO4762
9	2x PCD005
10	1x M10X25ISO4762
11	2x FED0618
12	2x M5X10ISO4762
kg	~1,8

Bestellbeispiel / Ordering example:
1x PS1F78N49-90 & 1x B90F78

	B90F78	B90W78	B90R78
C	78	78	78
H	25	25	25
L	23	28	23
D	11	11	11
e	15	15	15
i	HV700	*	HV700
	x0,2mm		x0,2mm
kg	~0,3	~0,37	~0,3

B90F78, B90W78	

* = weicher Stahl / soft steel

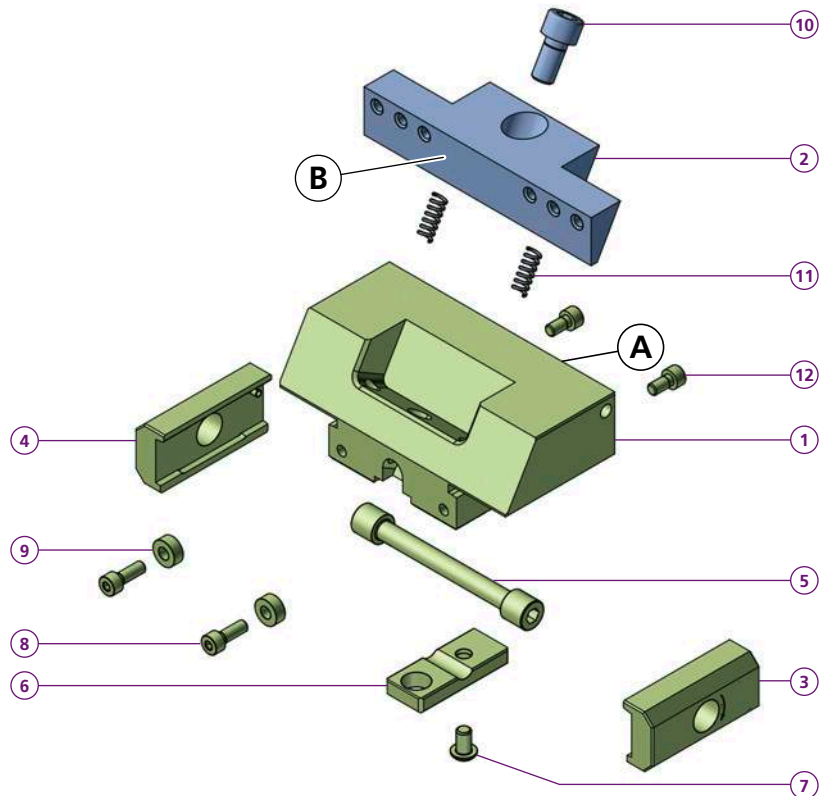
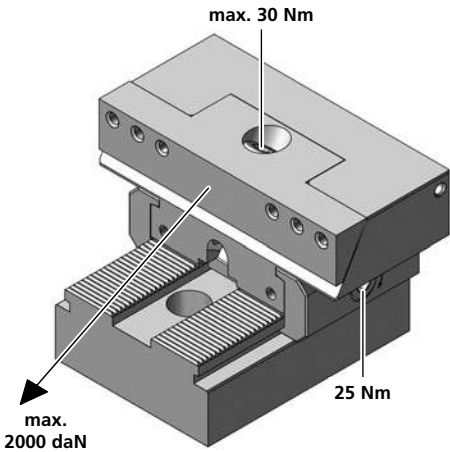
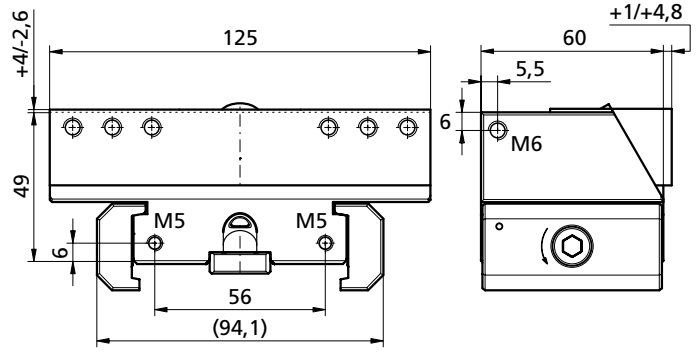
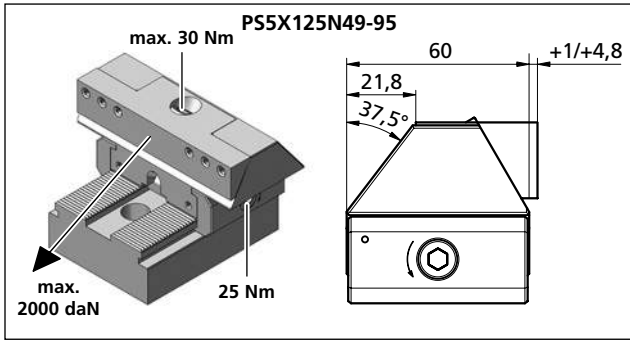

37,5°	PS5X125N49-95
1	1x TF140485
9	2x PCD005
8	2x M5X14ISO4762
kg	~2,0
	PS1F125N49-95
1	1x TF140483
	PS1R125N49-95
1	1x TF140484
2	1x —
3	1x PCSP60R
4	1x PCSP60L
5	1x PCS14
6	1x PCGU2049
7	1x M6X8ISO7380
8	2x M5X14ISO4762
9	2x PCD005
10	1x M10X25ISO4762
11	2x FED0618
12	2x M5X10ISO4762
kg	~2,3

Bestellbeispiel / Ordering example: 1x PS5X125N49-95 & 1x B95

	B95	B96	B97	B98	B99
C	125	125	125	125	125
H	25	25	25	25	25
L	23	23	23	30	23
D	11	11	11	11	11
ø	15	15	15	15	15
i	HV700	HV700	*	*	HV700
	x0,2mm	x0,2mm			x0,2mm
kg	~0,46	~0,45	~0,46	~0,63	~0,45

B95, B96, B97, B99		B98	
6xM6 (CCHMR)		110	
		84	
		58	
		6	

Separat bestellen / Order separately

PS2G94N44-13

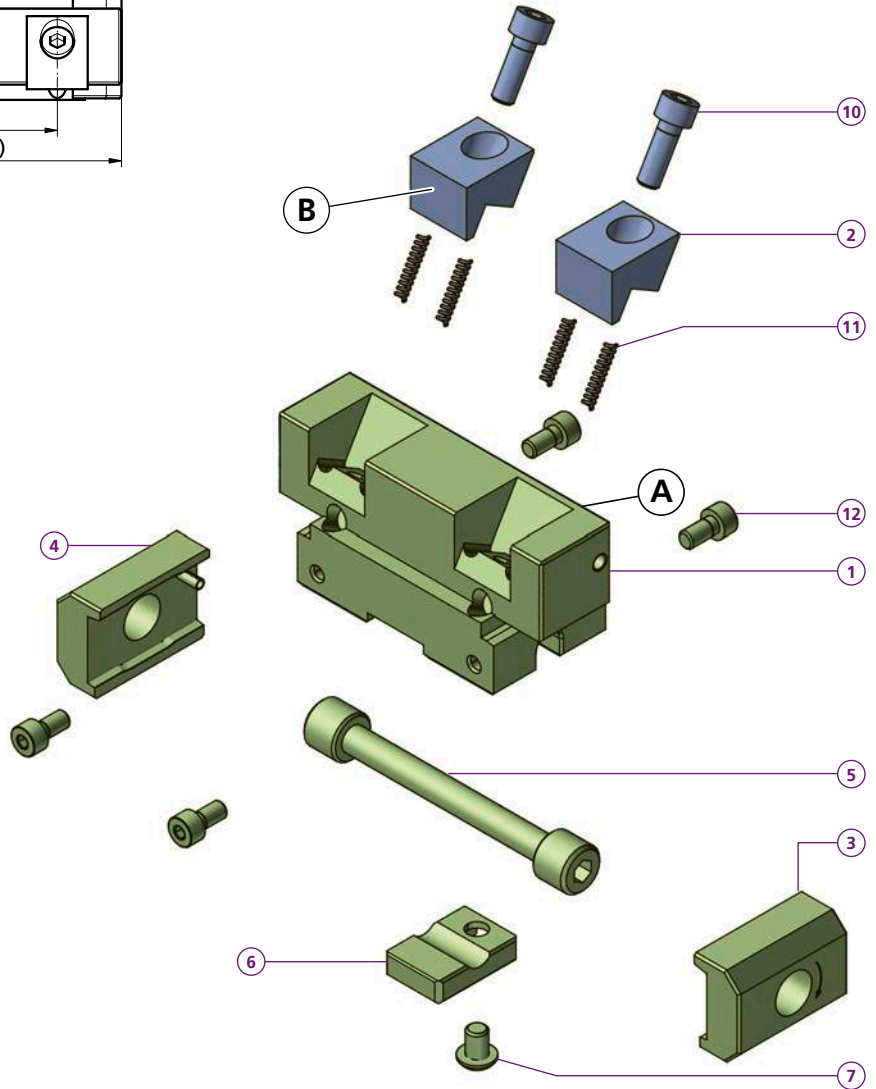
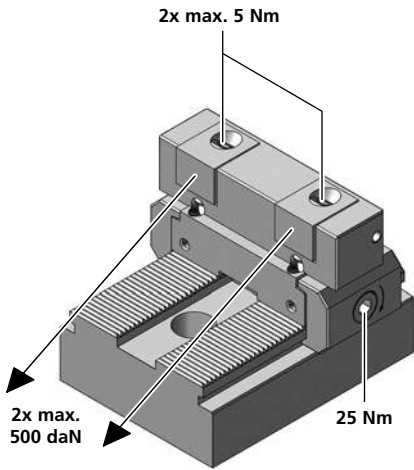
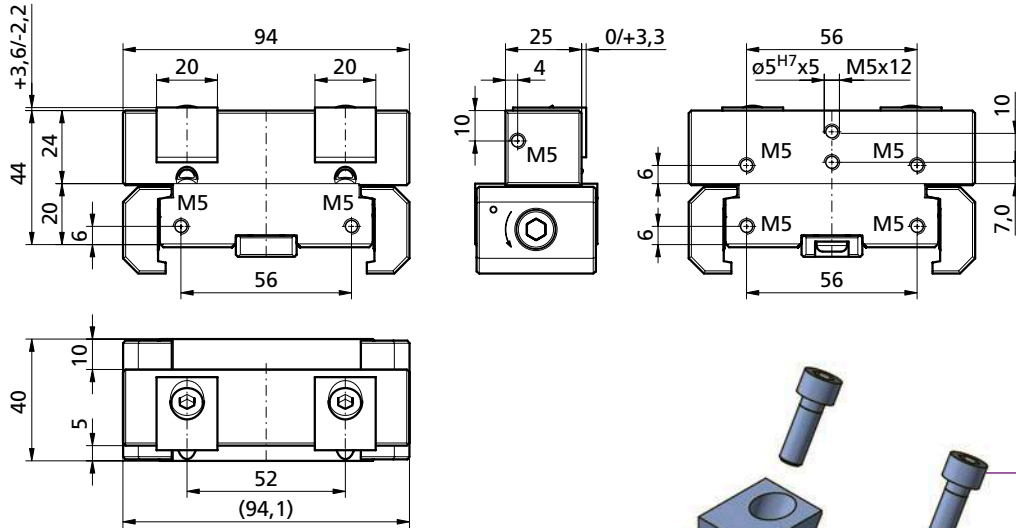

PS2G94N44-13	
1	1x TF140486
2	2x
3	1x PCSP40R
4	1x PCSP40L
5	1x PCS14
6	1x PCGU2030
7	1x M6X8ISO7380
10	2x M6X16ISO4762
11	4x FED0318
12	4x M5X10ISO4762
kg	~1,0

	B13	B14	B15	B16
C	20	20	20	20
H	16	16	16	16
L	13,8	13,8	13,8	19
D	6,5	6,5	6,5	6,5
ø	10	10	10	10
i	HV700	HV700	*	*
	x0,2mm	x0,2mm		
kg	~0,05	~0,05	~0,05	~0,06

Bestellbeispiel / Ordering example: 1x PS2G94N44-13 & 2x B14

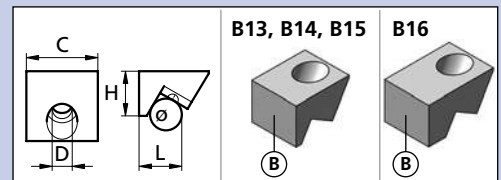

* = weicher Stahl / soft steel

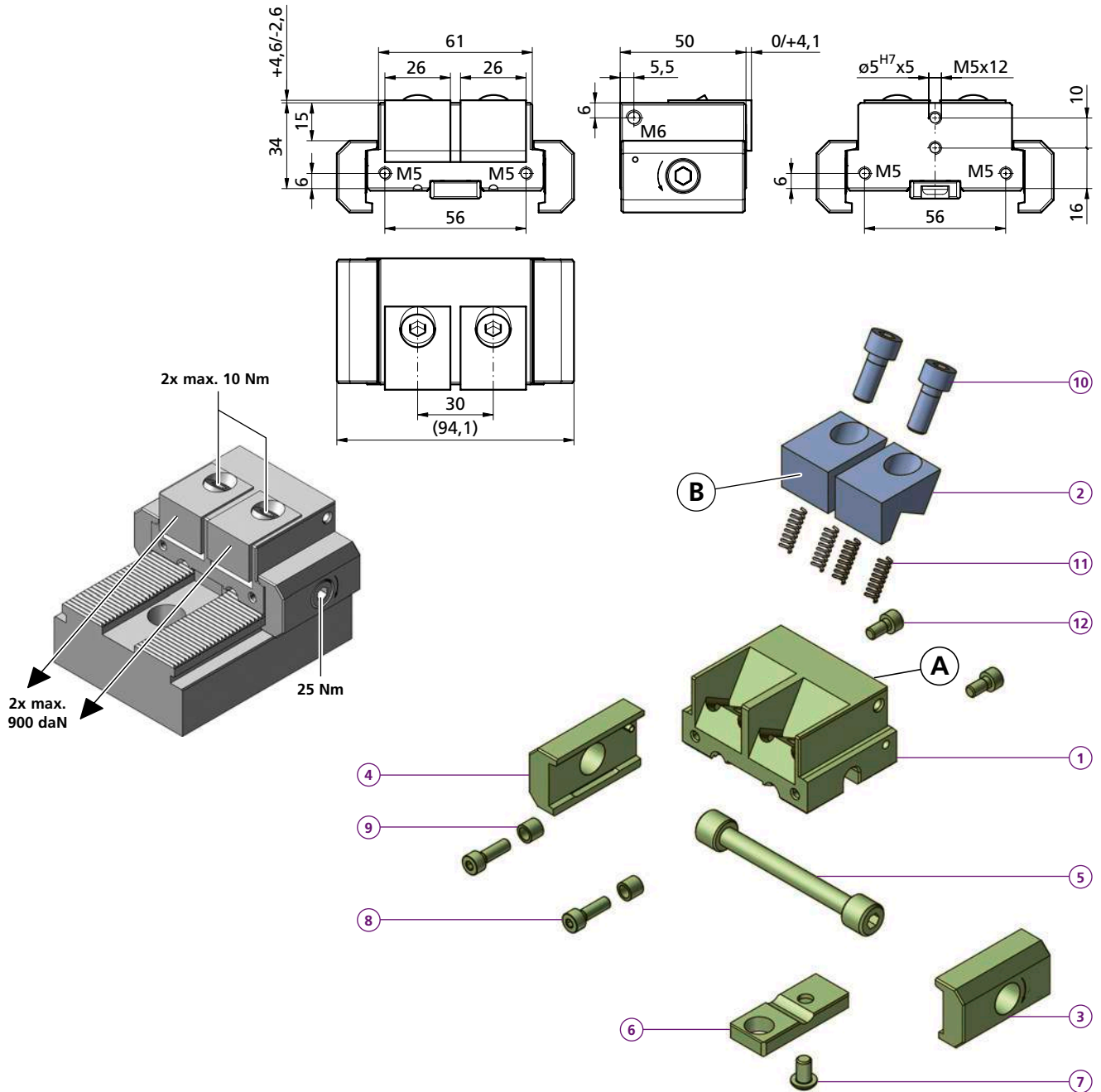

A	PS2F61N34-45
1	1x TF140487
A	PS2R61N34-45
1	1x TF140488
2	2x
3	1x PCSP50R
4	1x PCSP50L
5	1x PCS14
6	1x PCGU2049
7	1x M6X8ISO7380
8	2x M5X16ISO4762
9	2x PCD008
10	2x M8X20ISO4762
11	4x FED0618
12	2x M5X10ISO4762
kg	~1,0

Bestellbeispiel / Ordering example: 1x PS2R61N34-45 & 2x B47HM

	B45	B46	B47	B47HM
C	26	26	26	26
H	20	20	20	20
L	19	19	19,1	19,1
D	9	9	9	9
e	12	12	12	12
i	HV700	HV700	*	HM
	x0,2mm	x0,2mm		
kg	~0,1	~0,1	~0,1	~0,1

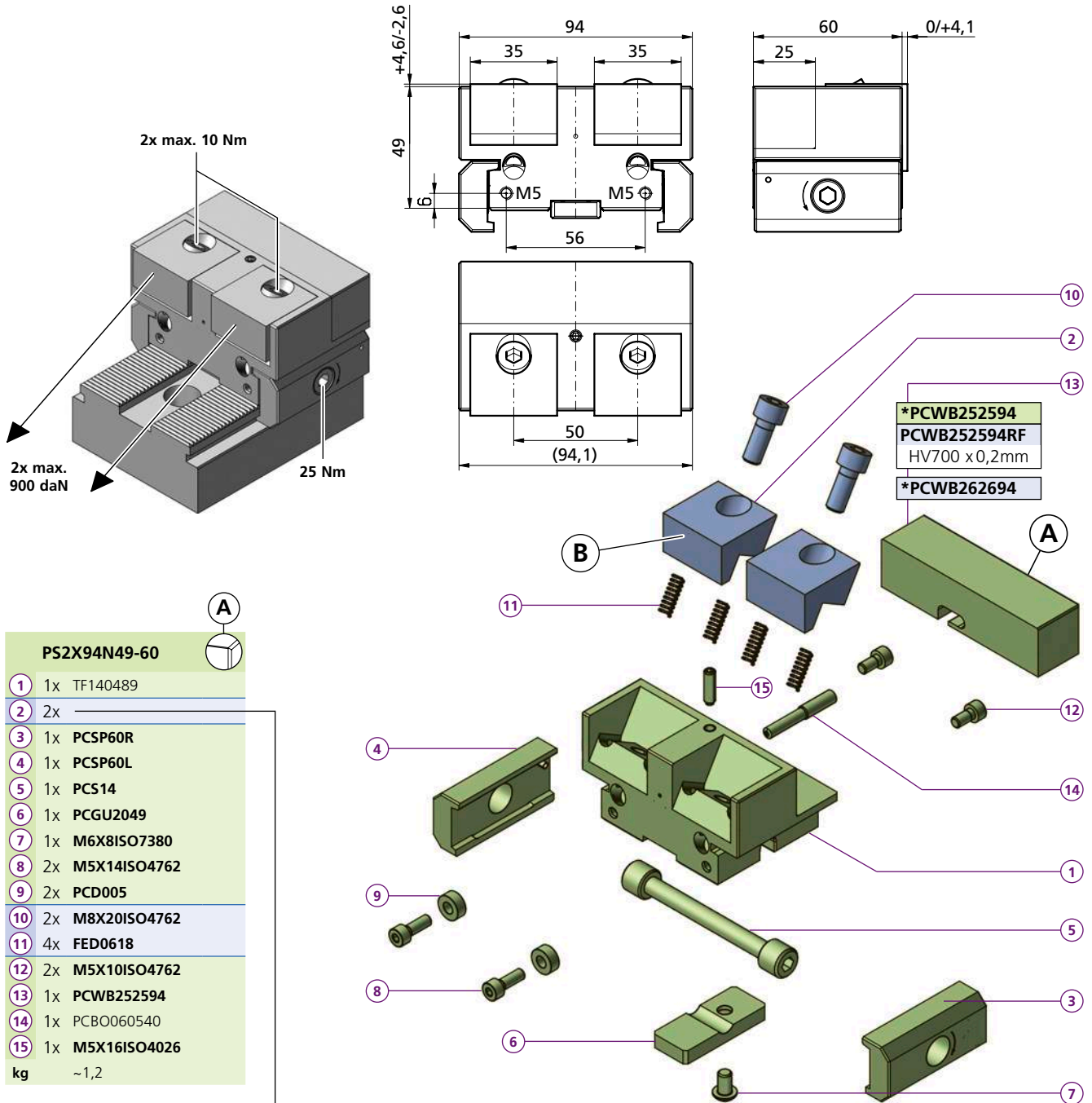

PS2X94N49-60

1	1x	TF140489
2	2x	
3	1x	PCSP60R
4	1x	PCSP60L
5	1x	PCS14
6	1x	PCGU2049
7	1x	M6X8ISO7380
8	2x	M5X14ISO4762
9	2x	PCD005
10	2x	M8X20ISO4762
11	4x	FED0618
12	2x	M5X10ISO4762
13	1x	PCWB252594
14	1x	PCBO060540
15	1x	M5X16ISO4026
kg		~1,2

Bestellbeispiel / Ordering example: 1x PS2X94N49-60 & 2x B58

	B58	B60	B61	B62	B62HM	B65	B66	B67	B68	B69	B77	B79F	B79R
C	35	35	35	35	35	35	35	35	35	35	35	35	35
H	20	20	20	20	20	20	20	20	20	25	20	20	20
L	26	19	19	19	19	19	19	24	26	22	22	25	25
D	9	9	9	9	9	9	9	9	9	9	9	9	9
o	12	12	12	12	12	12	12	12	12	12	12	12	12
i	ALU	56HRC	56HRC	*	HM	HV700 x0,2mm	HV700 x0,2mm	HV700 x0,2mm	*	*	56HRC	HV700 x0,2mm	HV700 x0,2mm
kg	~0,07	~0,12	~0,12	~0,12	~0,12	~0,12	~0,12	~0,14	~0,15	~0,15	~0,12	~0,18	~0,18

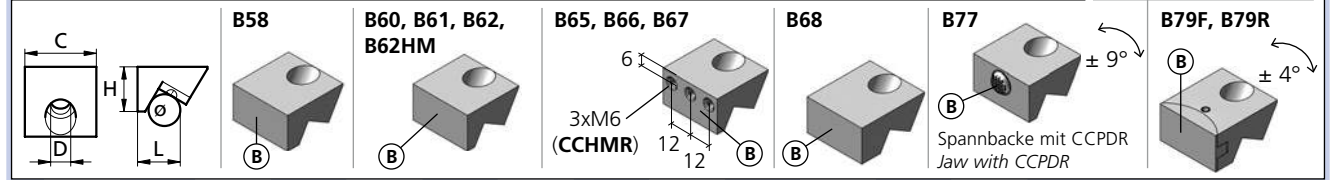
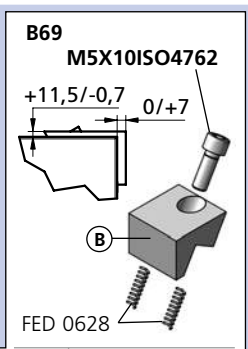

* = weicher Stahl / soft steel HM = Hartmetallbeschichtet / Carbide coated ALU = ENAW-7022

Separat bestellen / Order separately

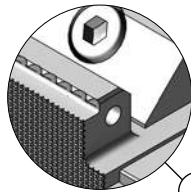
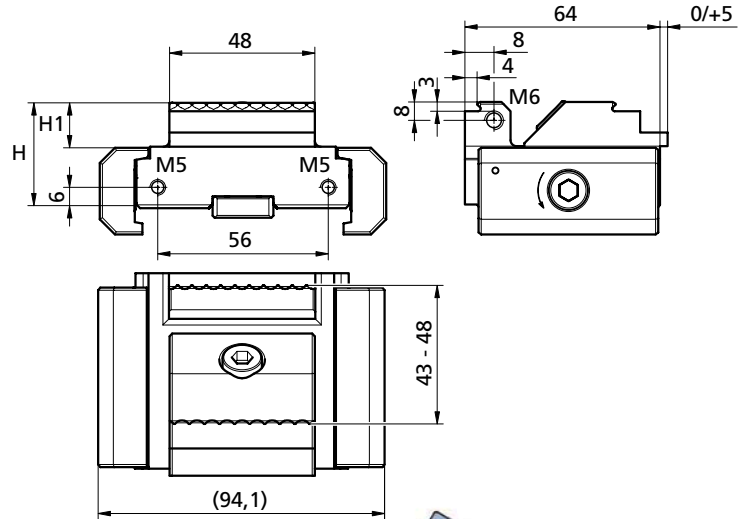
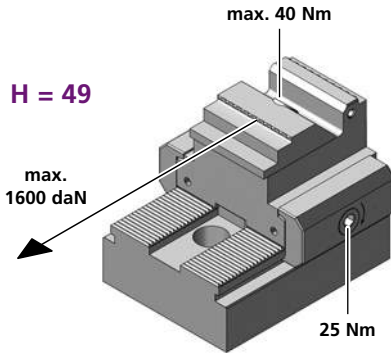
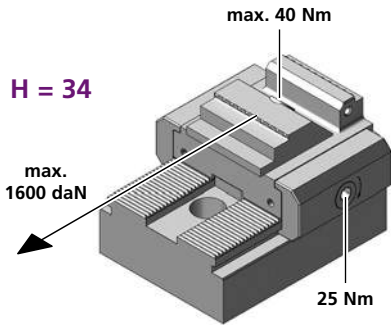

PS1P48L34-105

- 1 1x TW100098-01
- 2 1x
- 3 1x PCSP60R
- 4 1x PCSP60L
- 5 1x PCS14
- 6 1x PCGU2059
- 7 1x M6X8ISO7380
- 8 2x M5X14ISO4762
- 9 2x PCD005
- 10 1x M8X28ISO4762
- 11 1x PCUSR16
- 12 2x M5X10ISO4762
- 13 1x PCKMR45M8
- 14 2x D=6 DIN 5401
- H = 34
- H1 = 15
- kg ~1,0

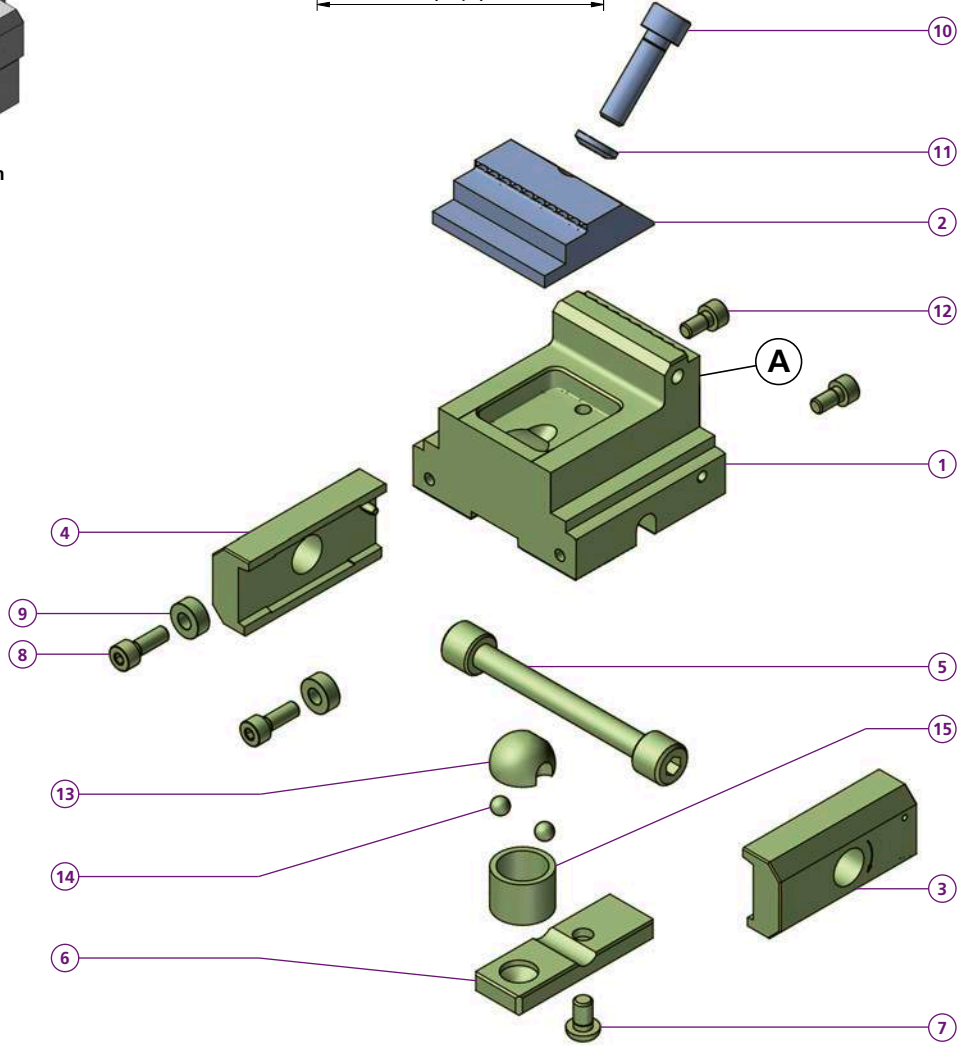

p. 84, 85

PS1PF48L34-105

- 1 1x TK140780
- H = 49
- H1 = 30
- kg ~1,0

PS1P48L49-105

- 1 1x TK120011
- 15 1x PCD20L15
- H = 49
- H1 = 30
- kg ~1,4

PS1PF48L49-105

- 1 1x TK140781
- 15 1x PCD20L15
- H = 49
- H1 = 30
- kg ~1,4

Bestellbeispiel / Ordering example:
1x PS1P48L34-105 & 1x B115

Drehmoment Torque		Spannkraft Workholding force		
Nm	(lb-ft)	~daN	~(lb)	~t
10	7,4	= 400	880	0,4
20	14,8	= 800	1'760	0,8
30	22,2	= 1'200	2'650	1,2
40	29,6	= 1'600	3'530	1,6

PS1P94L34-105

PS1P694L34-105

PS1P94L49-105

PS1PF94L49-105

PS1PF94L34-105

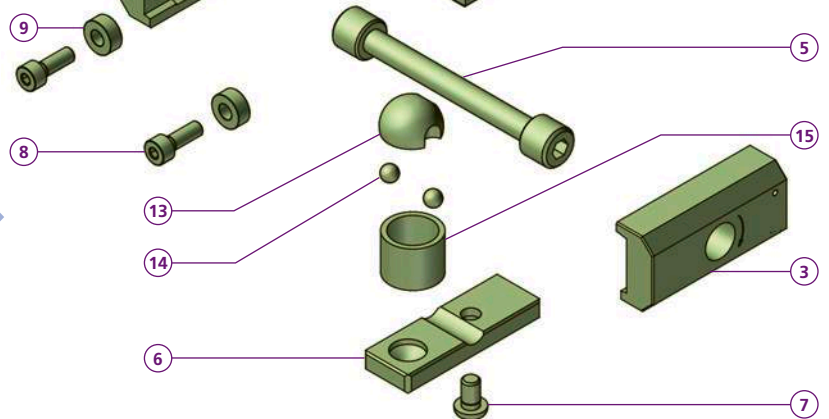
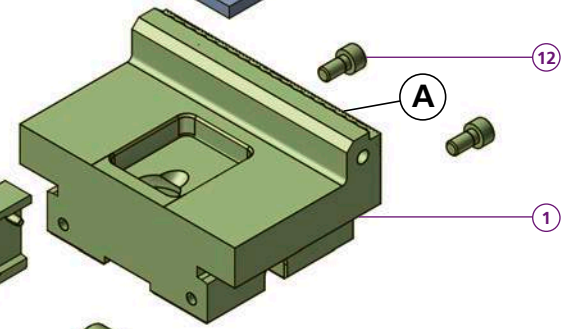
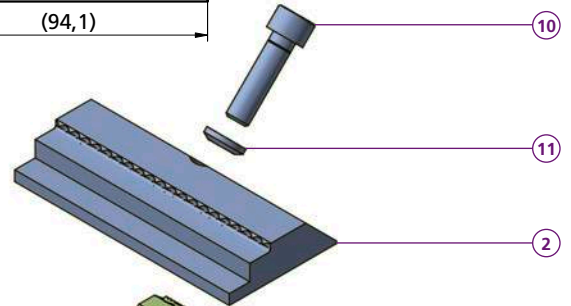
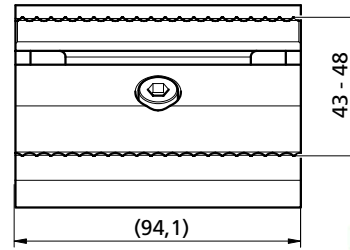
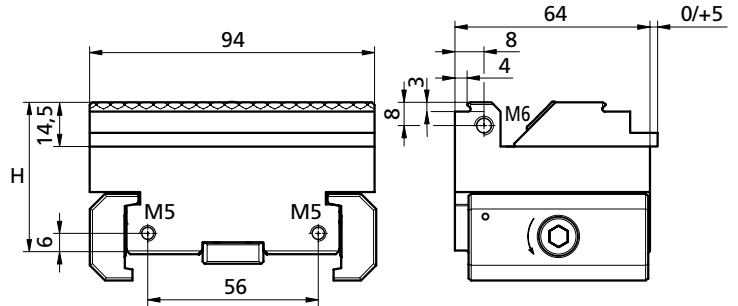
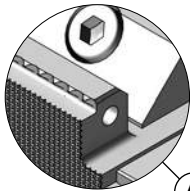
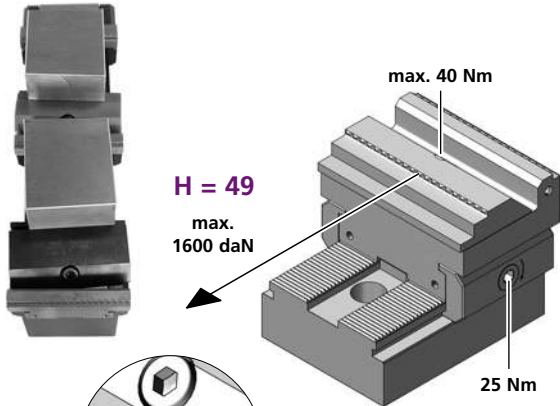
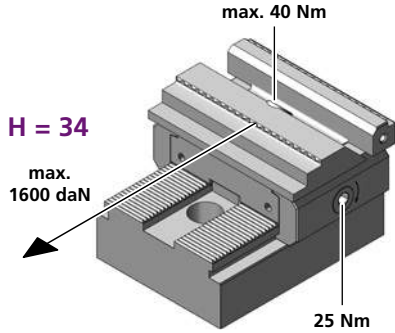

PS1P94L34-105

- 1 1x TW100100-01
 - 2 1x
 - 3 1x PCSP60R
 - 4 1x PCSP60L
 - 5 1x PCS14
 - 6 1x PCGU2059
 - 7 1x M6X8ISO7380
 - 8 2x M5X14ISO4762
 - 9 2x PCD005
 - 10 1x M8X28ISO4762
 - 11 1x PCUSR16
 - 12 2x M5X10ISO4762
 - 13 1x PCKMR45M8
 - 14 2x D=6 DIN 5401
- H = 34
kg ~1,1

p. 84, 85

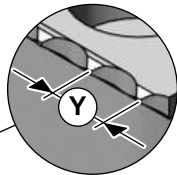

PS1P694L34-105

- 1 1x TW100100-02
 - Y 6,0 mm
- kg ~1,1

PS1PF94L34-105

- 1 1x TK140782
- H = 49
kg ~1,1

PS1P94L49-105

- 1 1x TK120857
 - 15 1x PCD20L15
- H = 49
kg ~1,8

PS1PF94L49-105

- 1 1x TK140783
 - 15 1x PCD20L15
- H = 49
kg ~1,8

Bestellbeispiel / Ordering example:
1x PS1P94L34-105 & 1x B120

Drehmoment Torque		Spannkraft Workholding force		
Nm	(lb-ft)	~daN	~(lb)	~t
10	7,4	= 400	880	0,4
20	14,8	= 800	1'760	0,8
30	22,2	= 1'200	2'650	1,2
40	29,6	= 1'600	3'530	1,6

PS1PV48L34-105
PS1R/F48L34-105

Linear
powerCLAMP

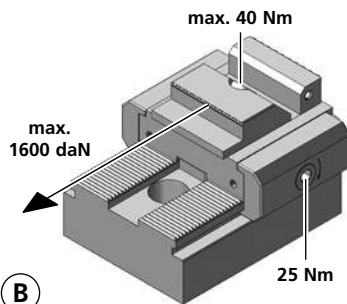
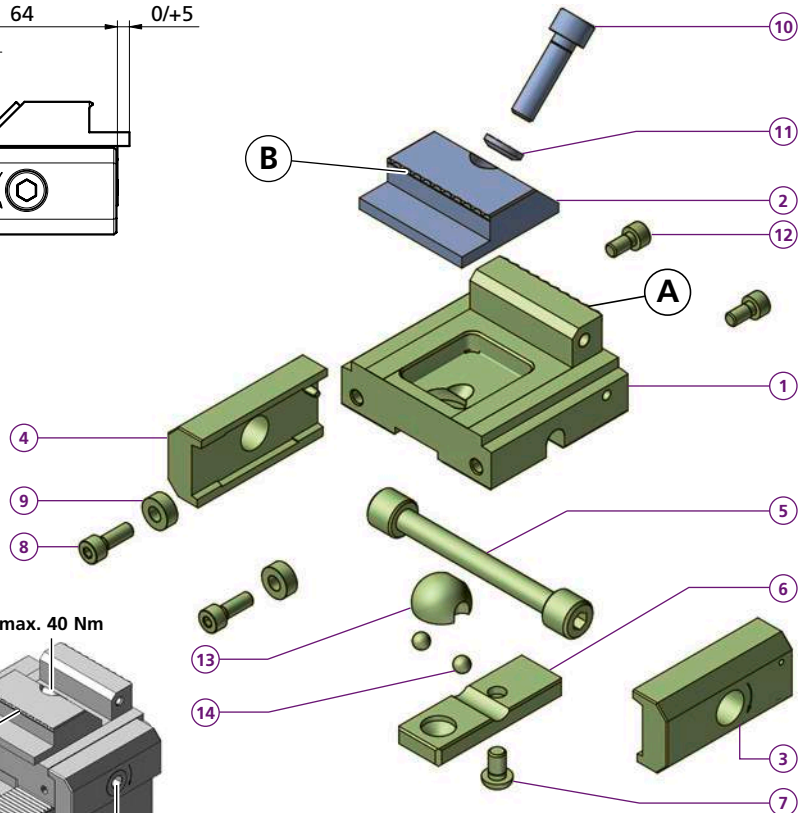
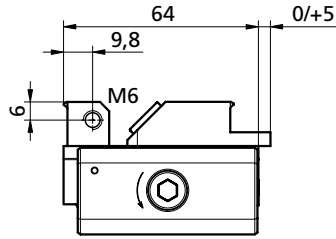
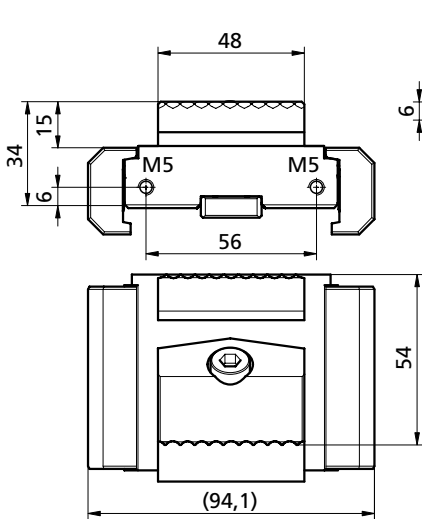

PS1PV48L34-105

1	1x	TK140762
2	1x	
3	1x	PCSP60R
4	1x	PCSP60L
5	1x	PCS14
6	1x	PCGU2059
7	1x	M6X8ISO7380
8	2x	M5X14ISO4762
9	2x	PCD005
10	1x	M8X28ISO4762
11	1x	PCUSR16
12	2x	M5X10ISO4762
13	1x	PCKMR45M8
14	2x	D=6 DIN 5401
kg		~1,0

B123P

C	48
H	14,5
L	47
i	56HRC
kg	~0,21

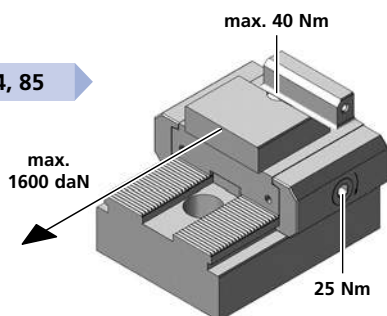
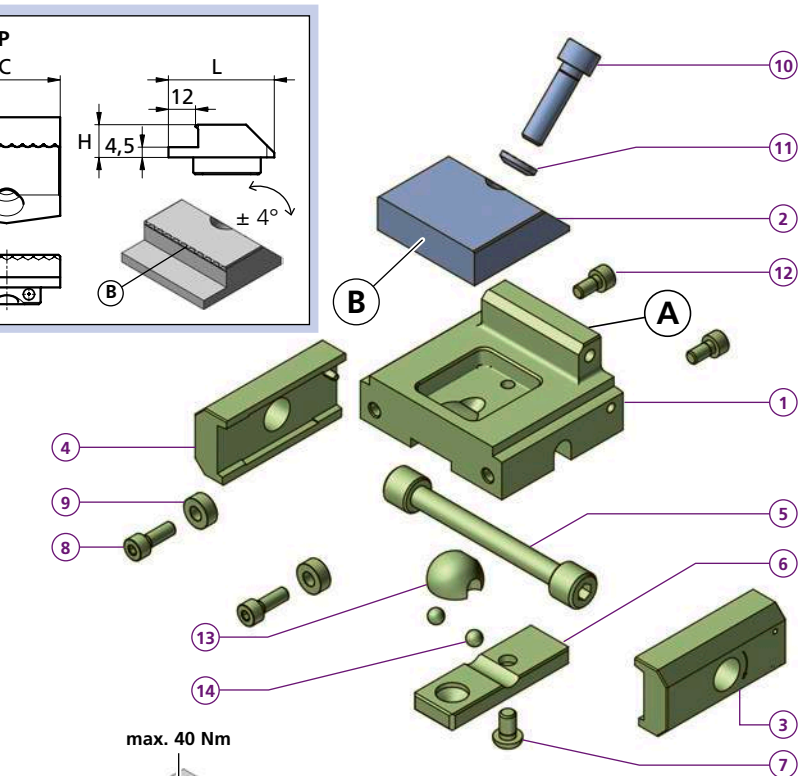

PS1R48L34-105

PS1F48L34-105

1	1x	TF140573
2	1x	
3	1x	PCSP60R
4	1x	PCSP60L
5	1x	PCS14
6	1x	PCGU2059
7	1x	M6X8ISO7380
8	2x	M5X14ISO4762
9	2x	PCD005
10	1x	M8X30ISO4762
11	1x	PCUSR14
12	2x	M5X10ISO4762
13	1x	PCKMR45M8
14	2x	D=6 DIN 5401
kg		~1,0

p. 84, 85

Bestellbeispiel / Ordering example:
1x PS1R48L34-105 & 1x B123P

Drehmoment Torque		Spannkraft Workholding force		
Nm	(lb-ft)	~daN	~(lb)	~t
10	7,4	= 400	880	0,4
20	14,8	= 800	1'760	0,8
30	22,2	= 1'200	2'650	1,2
40	29,6	= 1'600	3'530	1,6

Separat bestellen / Order separately

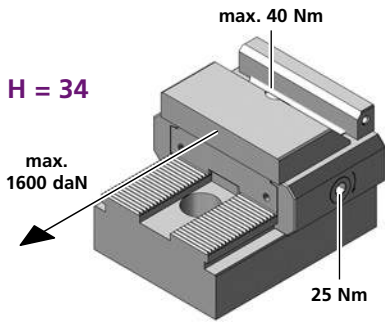

H = 34

max. 1600 daN

max. 40 Nm

25 Nm

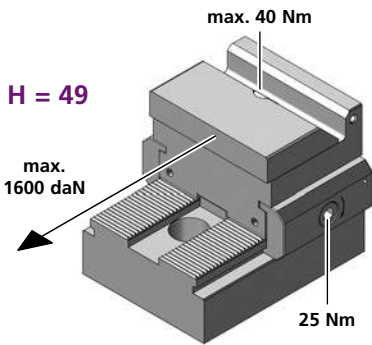

H = 49

max. 1600 daN

max. 40 Nm

25 Nm

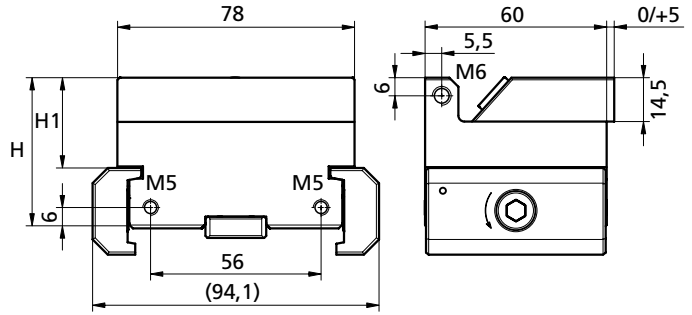

- PS1R78L34-105**
- 1 1x TF140575
- PS1F78L34-105**
- 1 1x TF140574
 - 2 1x
 - 3 1x PCSP60R
 - 4 1x PCSP60L
 - 5 1x PCS14
 - 6 1x PCGU2059
 - 7 1x M6X8ISO7380
 - 8 2x M5X14ISO4762
 - 9 2x PCD005
 - 10 1x M8X30ISO4762
 - 11 1x PCUSR14
 - 12 2x M5X10ISO4762
 - 13 1x PCKMR45M8
 - 14 2x D=6 DIN 5401
- H = 34
H1 = 15
kg ~1,0

p. 84, 85

- PS1R78L49-105**
- 1 1x TK110399
 - 15 2x PCD20L15
- PS1F78L49-105**
- 1 1x TK110400
 - 15 2x PCD20L15
- H = 49
H1 = 30
kg ~1,5

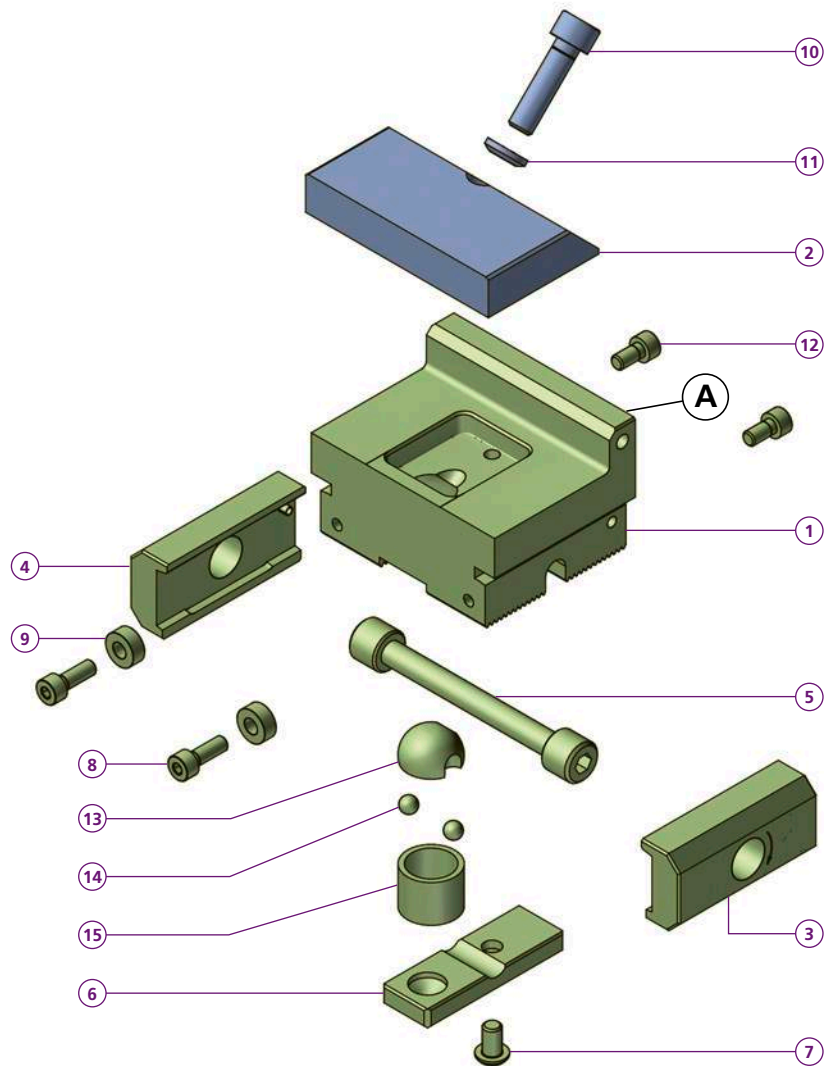

Bestellbeispiel / Ordering example:
1x PS1R48L34-105 & 1x B105

Drehmoment Torque		Spannkraft Workholding force		
Nm	(lb-ft)	~daN	~(lb)	~t
10	7,4	= 400	880	0,4
20	14,8	= 800	1'760	0,8
30	22,2	= 1'200	2'650	1,2
40	29,6	= 1'600	3'530	1,6

PS1PV94L34-105
PS1PV94L49-105

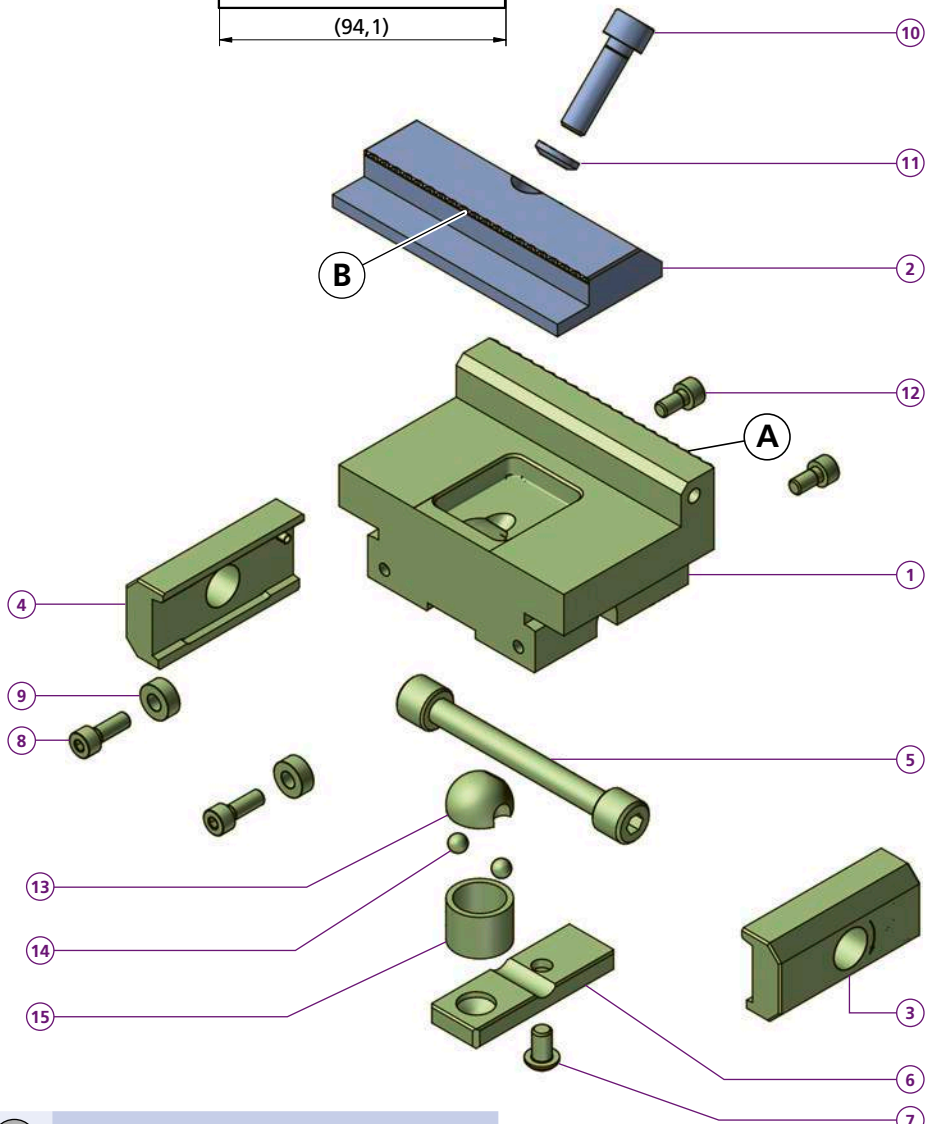
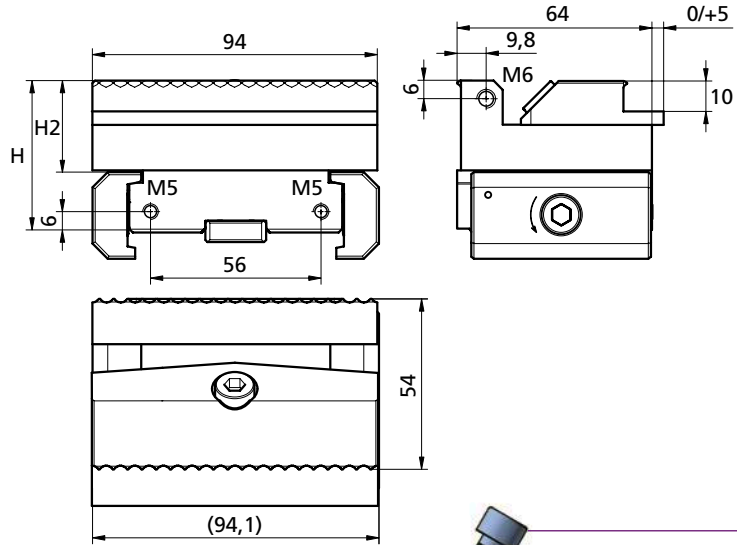
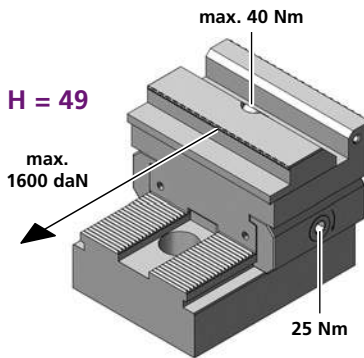
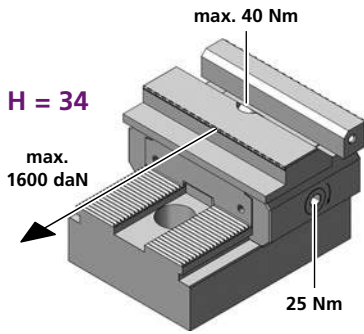

PS1PV94L34-105	
1	1x TK120230
2	1x
3	1x PCSP60R
4	1x PCSP60L
5	1x PCS14
6	1x PCGU2059
7	1x M6X8ISO7380
8	2x M5X14ISO4762
9	2x PCD005
10	1x M8X28ISO4762
11	1x PCUSR16
12	2x M5X10ISO4762
13	1x PCKMR45M8
14	2x D=6 DIN 5401
H	= 34
H1	= 15
kg	~1,1

PS1PV94L49-105	
1	1x TK110250
15	1x PCD20L15
H	= 49
H1	= 30
kg	~1,8

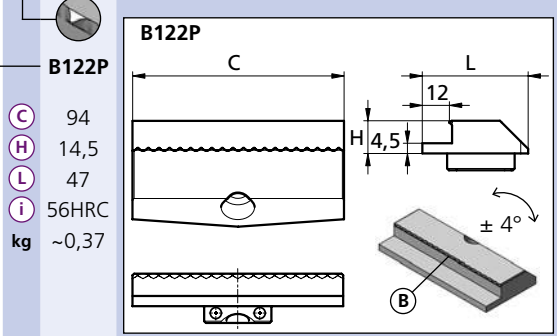

Bestellbeispiel / Ordering example:
1x PS1PV94L49-105 & 1x B122P

Drehmoment Torque		Spannkraft Workholding force		
Nm	(lb-ft)	~daN	~(lb)	~t
10	7,4	= 400	880	0,4
20	14,8	= 800	1'760	0,8
30	22,2	= 1'200	2'650	1,2
40	29,6	= 1'600	3'530	1,6

Separat bestellen / Order separately

PS1R/F48L49-105
PS5X48L49-105

Linear 5axes
powerCLAMP

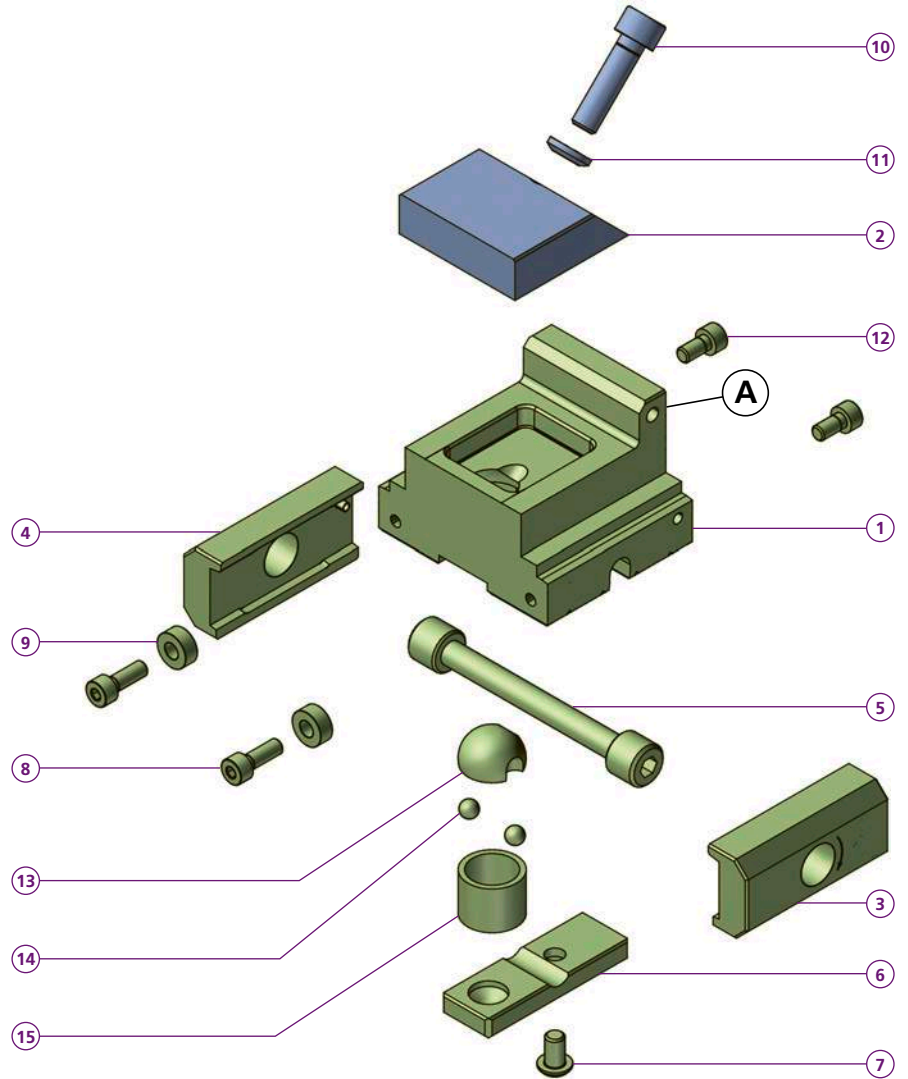
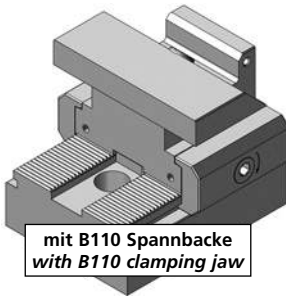
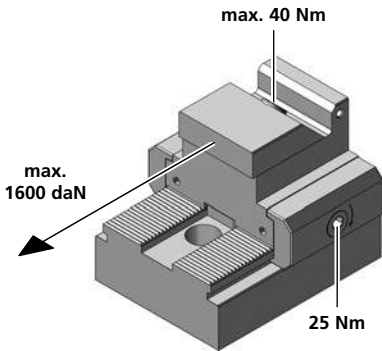
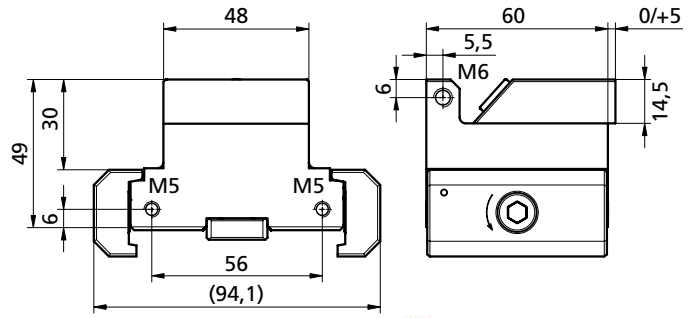
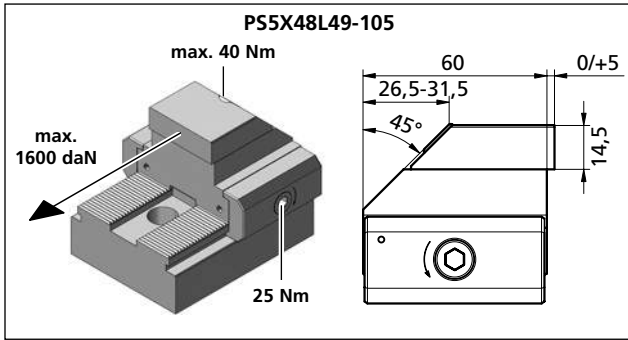

PS5X48L49-105
1x TF190651
2x PCD005
2x M5X14ISO4762
kg ~1,2
PS1F48L49-105
1x TF140673
PS1R48L49-105
1x TF140672
2x M8X30ISO4762
1x PCUSR14
2x M5X10ISO4762
1x PCKMR45M8
2x D=6 DIN 5401
1x PCD20L15
kg ~1,3

p. 84, 85



Bestellbeispiel / Ordering example:
1x PS1F48L49-105 & 1x B105

Drehmoment Torque	Spannkraft Workholding force		
	Nm (lb-ft)	~daN	~(lb) ~t
10	7,4 =	400	880 0,4
20	14,8 =	800	1'760 0,8
30	22,2 =	1'200	2'650 1,2
40	29,6 =	1'600	3'530 1,6

Separat bestellen / Order separately

PS5X48L34-105

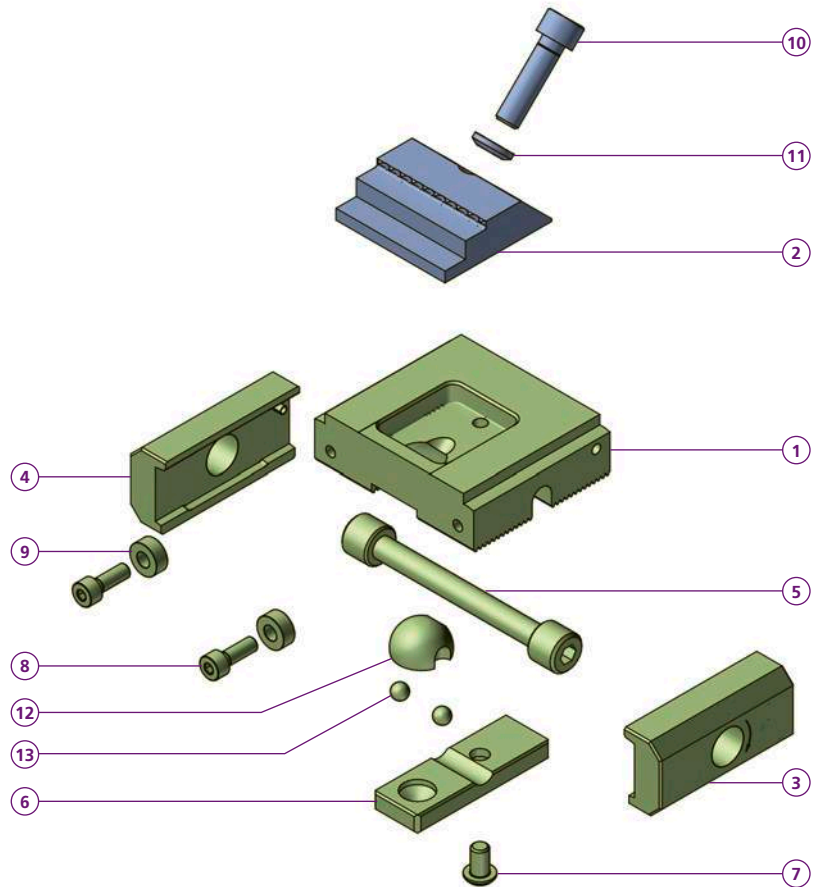
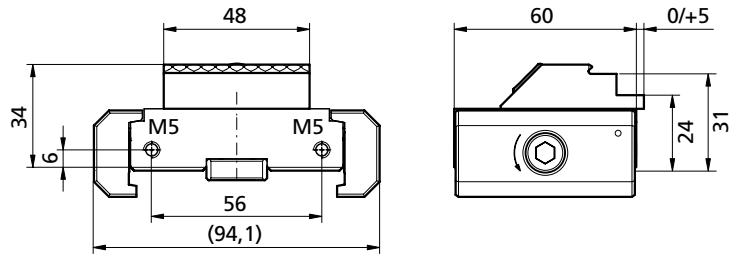
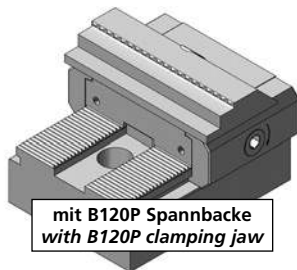
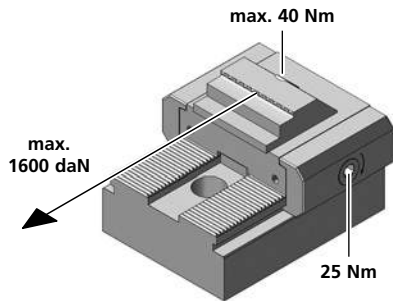

PS5X48L34-105	
1	1x T00365
2	1x
3	1x PCSP60R
4	1x PCSP60L
5	1x PCS14
6	1x PCGU2059
7	1x M6X8ISO7380
8	2x M5X14ISO4762
9	2x PCD005
10	1x M8X28ISO4762
11	1x PCUSR16
12	1x PCKMR45M8
13	2x D=6 DIN 5401
kg	~0,9

p. 84, 85

Bestellbeispiel / Ordering example:
1x PS5X48L34-105 & 1x B105

Drehmoment Torque	Spannkraft Workholding force		
	Nm (lb-ft)	~daN	~(lb) ~t
10	7,4 =	400	880 0,4
20	14,8 =	800	1'760 0,8
30	22,2 =	1'200	2'650 1,2
40	29,6 =	1'600	3'530 1,6

Separat bestellen / Order separately

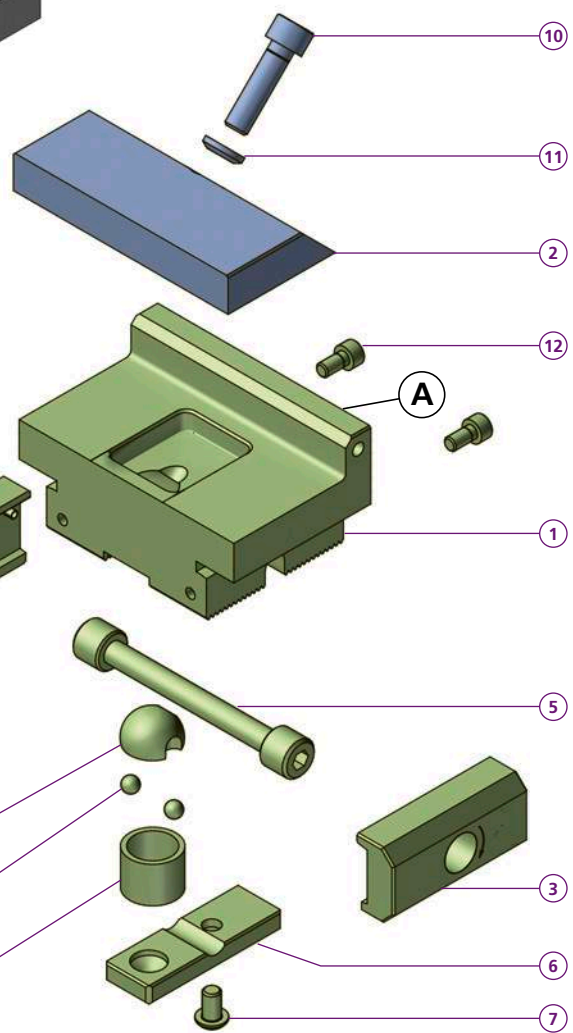
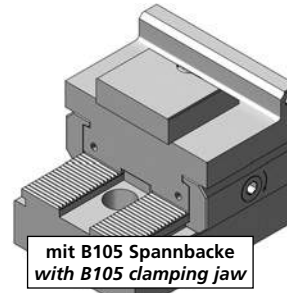
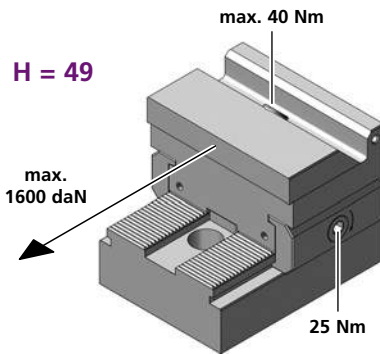
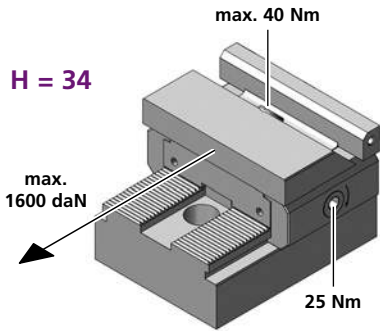
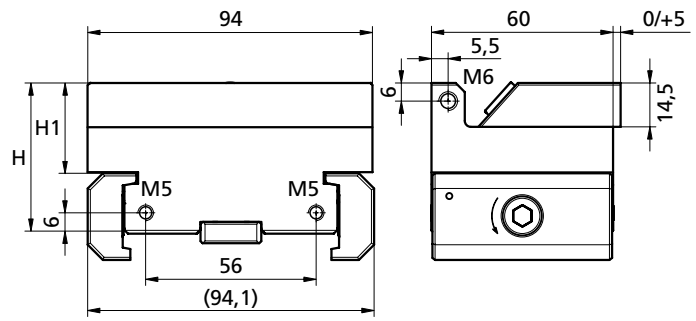
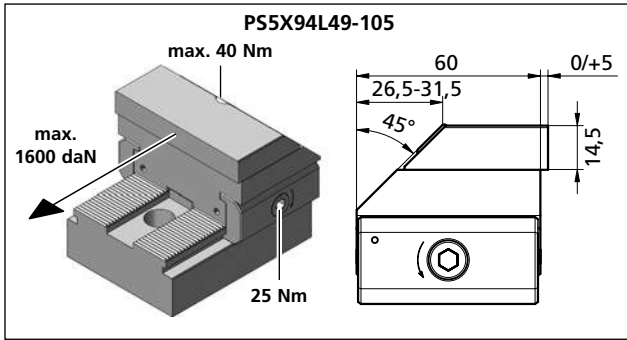

	PS5X94L49-105
1	1x TW100186
15	2x PCD20L15
9	2x PCD005
8	2x M5X14ISO4762
kg	~1,5
	PS1F94L34-105
1	1x TH130785
	PS1R94L34-105
1	1x TH130786
2	1x p. 84, 85
3	1x PCSP60R
4	1x PCSP60L
5	1x PCS14
6	1x PCGU2059
7	1x M6X8ISO7380
8	2x M5X14ISO4762
9	2x PCD005
10	1x M8X30ISO4762
11	1x PCUSR14
12	2x M5X10ISO4762
13	1x PCKMR45M8
14	2x D=6 DIN 5401
H	= 34
H1	= 15
kg	~1,0

	PS1F94L49-105
1	1x TF140674
15	2x PCD20L15
	PS1R94L49-105
1	1x TF140675
15	2x PCD20L15
H	= 49
H1	= 30
kg	~1,7

Bestellbeispiel / Ordering example:
1x PS1R94L49-105 & 1x B105

Drehmoment Torque	Spannkraft Workholding force		
	Nm (lb-ft)	~daN	~(lb) ~t
10	7,4 = 400	880	0,4
20	14,8 = 800	1'760	0,8
30	22,2 = 1'200	2'650	1,2
40	29,6 = 1'600	3'530	1,6

Separat bestellen / Order separately

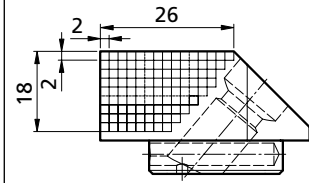

Zum Erstellen Ihrer individuellen Formbacke: *If a dedicated jaw is being machined:*
 Schnittzeichnung zum Ermitteln der maximalen Bearbeitungsprofiltiefe
Sectional drawing to determine the maximum machining depth

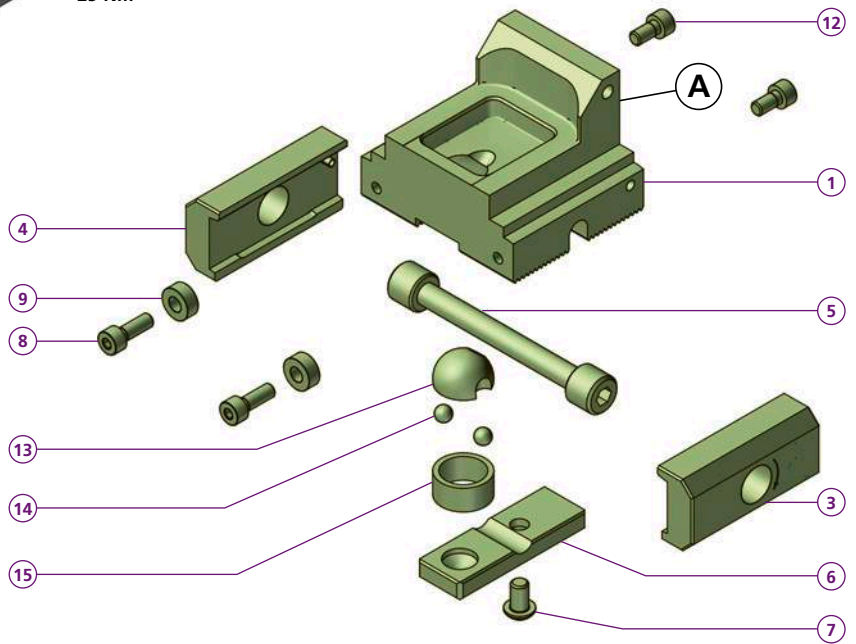
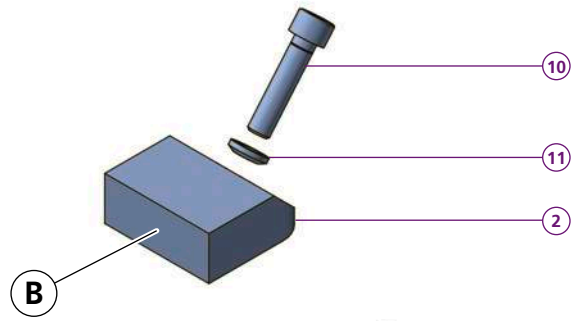
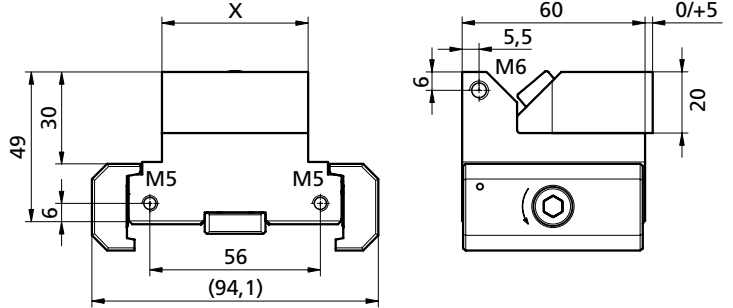
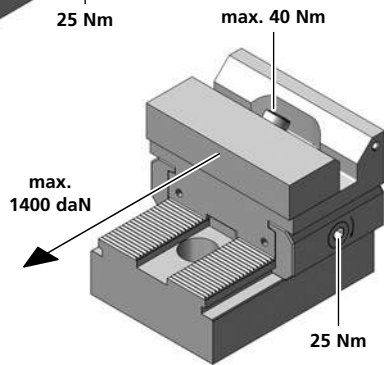
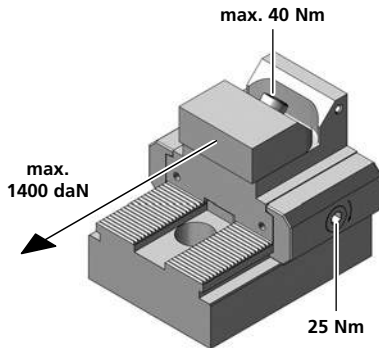

PS1R48L49-105H20	
1	1x TW100161-01
2	1x
3	1x PCSP60R
4	1x PCSP60L
5	1x PCS14
6	1x PCGU2059
7	1x M6X8ISO7380
8	2x M5X14ISO4762
9	2x PCD005
10	1x M8X35ISO4762
11	1x PCUSR14
12	2x M5X10ISO4762
13	1x PCKMR45M8
14	2x D=6 DIN 5401
15	1x PCD20L095
X	= 48
kg	~1,2
PS1R94L49-105H20	
1	1x TW100161-07
X	= 94
kg	~1,5

Bestellbeispiel / Ordering example: 1x PS1R48L49-105H20 & 1x B107H20

	B105H20	B106H20	B107H20	B110H20	B111H20	B112H20
C	48	48	48	94	94	94
H	20	20	20	20	20	20
L	47	47	47	47	47	47
i	HV700 x0,2mm	HV700 x0,2mm	*	HV700 x0,2mm	HV700 x0,2mm	*
kg	~0,38	~0,38	~0,38	~0,57	~0,56	~0,56

Separat bestellen / Order separately

PS1R125L49-105H20

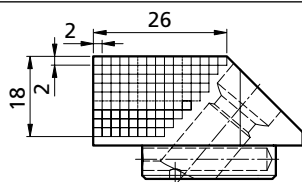

Zum Erstellen Ihrer individuellen Formbacke: *If a dedicated jaw is being machined:*
 Schnittzeichnung zum Ermitteln der maximalen Bearbeitungsprofiltiefe
 Sectional drawing to determine the maximum machining depth

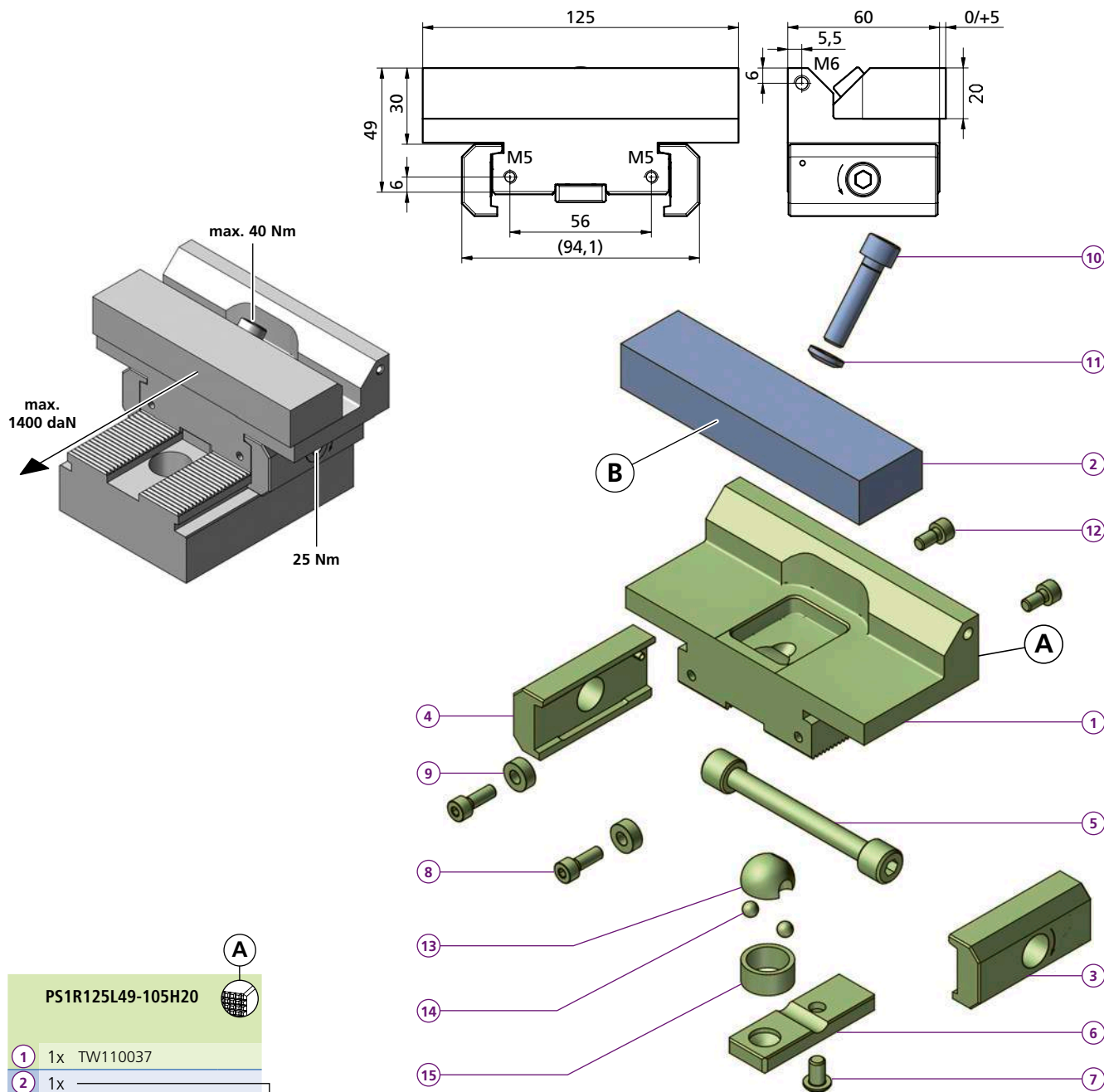

PS1R125L49-105H20	
1	1x TW110037
2	1x
3	1x PCSP60R
4	1x PCSP60L
5	1x PCS14
6	1x PCGU2059
7	1x M6X8ISO7380
8	2x M5X14ISO4762
9	2x PCD005
10	1x M8X35ISO4762
11	1x PCUSR14
12	2x M5X10ISO4762
13	1x PCKMR45M8
14	2x D=6 DIN 5401
15	1x PCD20L095
kg	~1,7

Bestellbeispiel / Ordering example: 1x PS1R125L49-105H20 & 1x B132H20P

	B130H20P	B131H20P	B132H20P
C	125	125	125
H	20	20	20
L	47	47	47
i	HV700	HV700	*
kg	~0,71	~0,71	~0,71

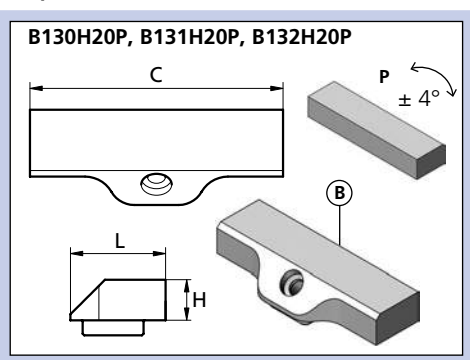

* = weicher Stahl / soft steel

Separat bestellen / Order separately

Linear- Spannbacken ... Linear clamping jaws ...



powerCLAMP

zum Einsatz in unterschiedlichen Spannsituationen
for use in different clamping situations

Art. Nr.				kg
B110	HV700 x 0,2mm			~0,49
B110P	HV700 x 0,2mm	$\pm 4^\circ$		~0,49



mit Prägeeinsätzen
with direct-stamping inserts

Art. Nr.			kg
B110P-PRGM8	HV700 x 0,2mm		~0,46

Art. Nr.			kg
B111	HV700 x 0,2mm		~0,48
B111P	HV700 x 0,2mm	$\pm 4^\circ$	~0,48

B112	weicher Stahl soft steel (1.2312)			~0,49
B112P	weicher Stahl soft steel (1.2312)	$\pm 4^\circ$		~0,49
B112HG	Hochgenau High-precision			~0,49
B112E	Einsatzstahl (1.5752) Case hardening steel			~0,49
B112EP	Einsatzstahl (1.5752) Case hardening steel	$\pm 4^\circ$		~0,47

B113	HV700 x 0,2mm			~0,39
B113P	HV700 x 0,2mm	$\pm 4^\circ$		~0,39

B117P	57HRC	$\pm 4^\circ$		~0,46
--------------	-------	---------------	--	-------

B120	57HRC			~0,4
-------------	-------	--	--	------

B120P	57HRC	$\pm 4^\circ$		~0,4
--------------	-------	---------------	--	------

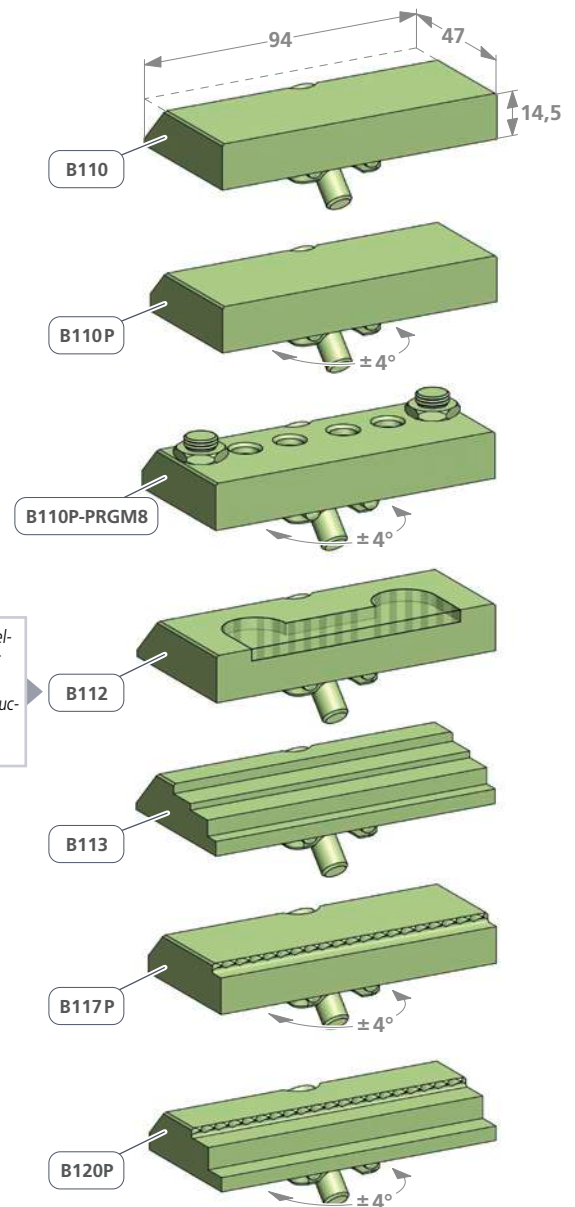

Modulhöhen / Module heights 34 / 49 mm

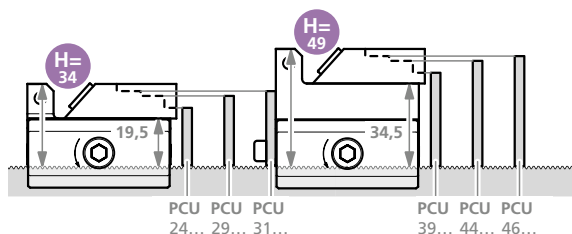

Beim Einsatz einer Stufenbacke, ist die richtige Modulspannhöhe 34 mm / 49 mm zu berücksichtigen. Die Werkstücke auf der Anschlagseite werden mit den passenden Parallelunterlagen abgestützt.

When using a step jaw is applied, the correct module clamping height 34 mm / 49 mm must be taken into account. The workpieces on the end module are supported with the appropriate steel parallel.

Eingesetzte Stufenbacken / Inserted stepped jaws (B113)

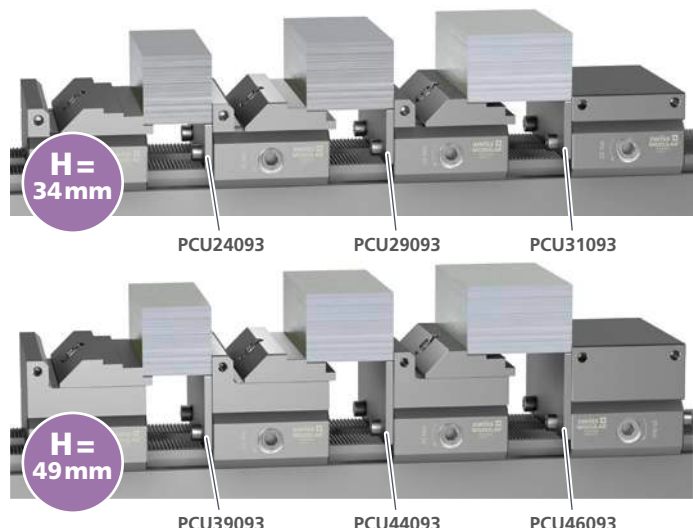

Linear- Spannbacken ... Linear clamping jaws ...



powerCLAMP

zum Einsatz in unterschiedlichen Spannsituationen
for use in different clamping situations

Art.Nr.				kg
B140	HV700 x 0,2mm			~0,41
B140P	HV700 x 0,2mm	$\pm 4^\circ$		~0,41
B141	HV700 x 0,2mm			~0,41
B141P	HV700 x 0,2mm	$\pm 4^\circ$		~0,41
B105	HV700 x 0,2mm			~0,27
B105P	HV700 x 0,2mm	$\pm 4^\circ$		~0,27
B105-15	HV700 x 0,2mm			~0,27
B106	HV700 x 0,2mm			~0,27
B106P	HV700 x 0,2mm	$\pm 4^\circ$		~0,27
B107	weicher Stahl soft steel (1.2312)			~0,27
B107P	weicher Stahl soft steel (1.2312)	$\pm 4^\circ$		~0,27
B108	HV700 x 0,2mm			~0,22
B108P	HV700 x 0,2mm	$\pm 4^\circ$		~0,22
B115	57HRC			~0,21
B115P	57HRC	$\pm 4^\circ$		~0,21
B116P	57HRC	$\pm 4^\circ$		~0,25

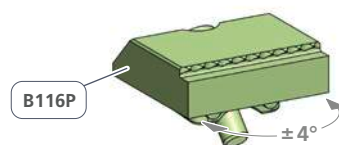
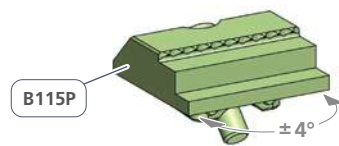
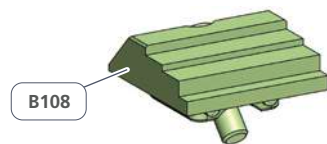
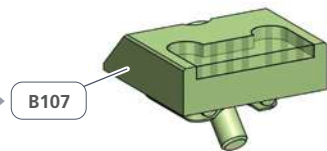
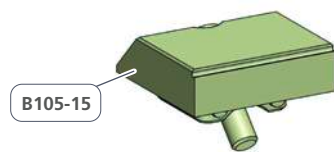
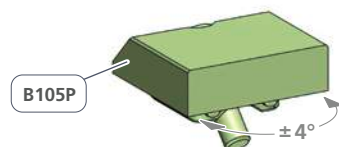
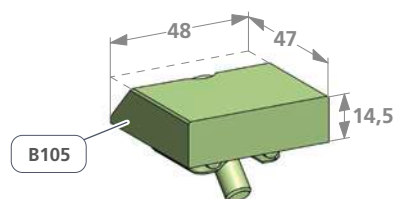
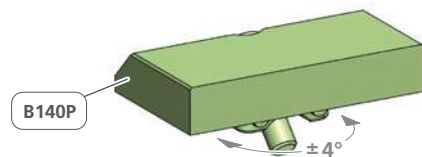
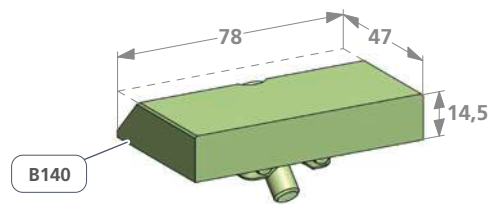

Weich, zur Herstellung individueller Formbacke.
Soft, for the production of individual moulding jaw.

Für Prägebacken / For stamping jaws

PF-SET Kräftehaltung mit Nachfederung
Spring loaded mechanism to maintain clamping force

Bei allen Prägebacken kann die Kräftehaltung mit den nachfedernden Tellerfedern eingesetzt werden um ein Freiwigeln des Werkstücks zu verhindern.

On every spring loaded stamping jaw, the force retention with the disc springs can be used to prevent the workpiece from wiggling free.



Die Tellerfedern werden gegenläufig montiert.

The disc springs are mounted in opposite directions.



Detailvermessung der Stufenbacken / Detailed dimensioning of the stepped jaws

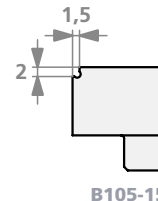
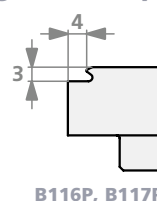
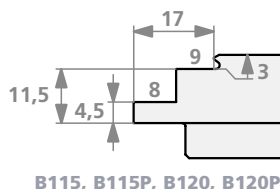
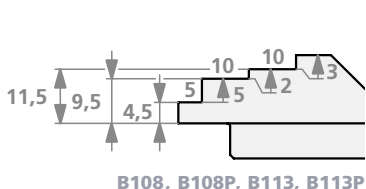

Anschlagmodule ... End module ...

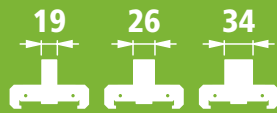

5axes powerCLAMP

für die horizontale und vertikale Bearbeitung
for horizontal and vertical machining

Art. Nr.	kg	X
PAND19-49	~1,2	19
PAND26-49	~2,2	26
PAND34-49	~2,3	34

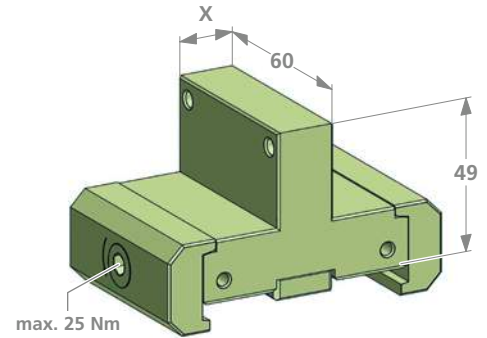

Schmale Anschlagmodule und Werkstücke
in der Mehrfachspannung.

Slim stop modules and workpieces in
multiple clamping.

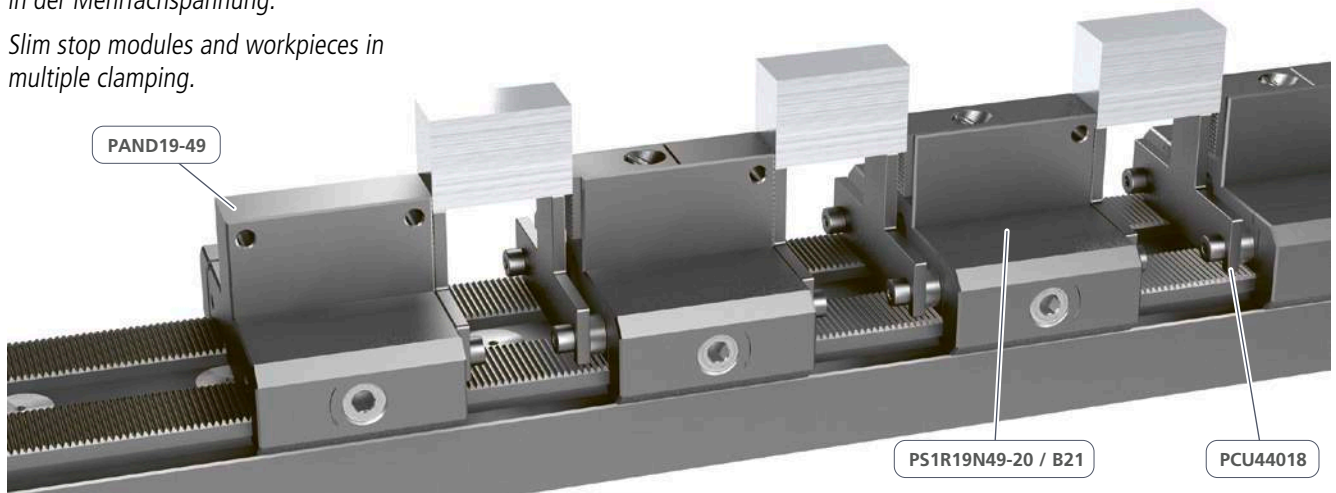

für 5-Achs Bearbeitung
for 5-axis machining

Art. Nr.	kg	X
PA5X19-49F	~1,1	19
PA5X19-49R	~1,1	19
PA5X26-49F	~1,2	26
PA5X26-49R	~1,2	26
PA5X34-49F	~1,2	34
PA5X34-49R	~1,2	34

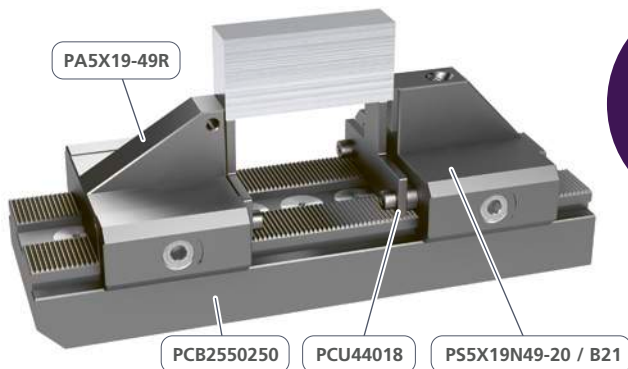
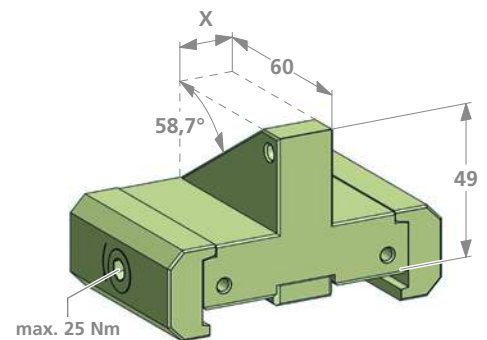

Module
einsetzbar auf
Zentrischspannern
oder Basisschienen.
Modules
can be used on self
centrig vises or
base rails.



Anschlagmodule ...
End module ...

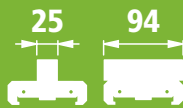

powerCLAMP

für die horizontale und vertikale Bearbeitung
for horizontal and vertical machining

Art. Nr.	kg
PAND25-44	~1,1

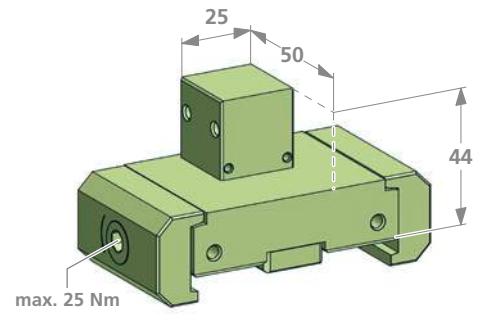

Schlankes und kurzes Anschlagmodul für Kleinteil-Serien (Mehrfachspannung).

Slim and short end module for small part series (Multiple workholding).

Art. Nr.	kg
PAND94-44	~1,3

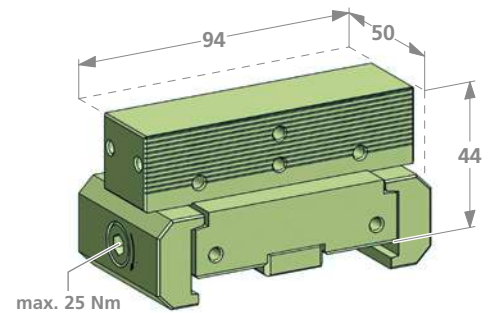

Die Anschlagfläche enthält 2 Passbohrungen. Mit MS50 Passschrauben kann mittig ein Seitenanschlag präzise platziert werden.

The stop surface contains 2 fitting holes. A side stop can be placed precisely in the centre with MS50 fitting screws.

Anschlagmodul mit Doppelspannfunktion. Verdoppelt die Anzahl Spannbereiche auf gleichbleibendem Raum.

End module with double clamping function. Doubles the number of clamping areas in the same amount of working space.

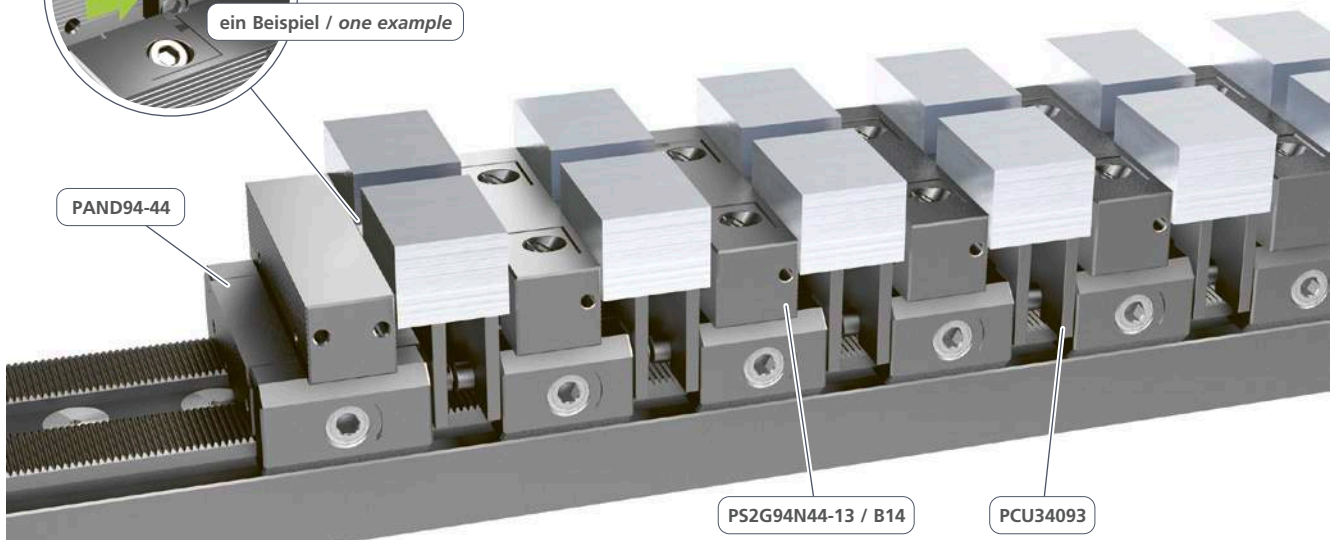

Anschlagmodule ... End module ...

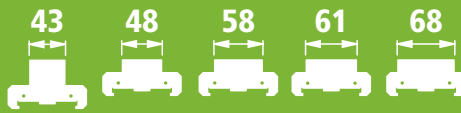

5axes powerCLAMP

für die horizontale und vertikale Bearbeitung
for horizontal and vertical machining

Art. Nr.		kg	X	H
PAND43-49		~1,6	43	49
PAND48-34		~1,3	48	34
PAND48-49		~1,6	48	49
PAND48-75		~2,2	48	75
PAND58-34		~1,4	58	34
PAND58-49		~1,8	58	49
PAND61-34		~1,4	61	34
PAND68-34		~2,3	68	34

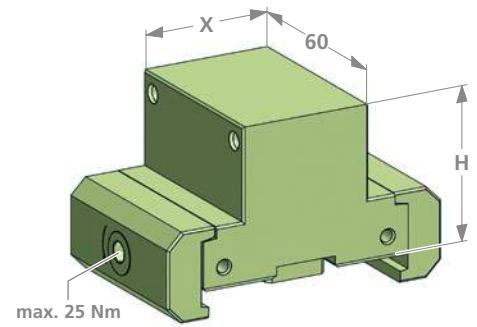

43 mm bis 68 mm breite Anschlagmodule für die Einzel- und Mehrfachspannung.
43 mm to 68 mm wide end modules for single and multiple clamping.

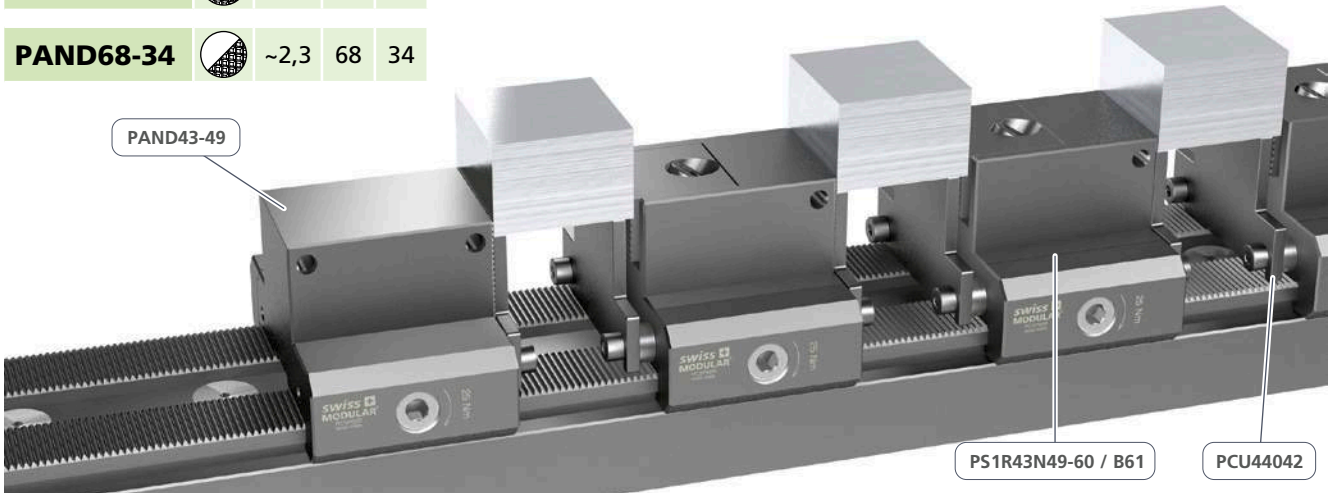

für 5-Achs Bearbeitung
for 5-axis machining

Art. Nr.		kg	X
PA5X43-49F		~1,3	43
PA5X43-49R		~1,3	43
PA5X48-49F		~1,4	48
PA5X48-49R		~1,4	48



Module einsetzbar auf Zentrischspannern oder Basisschienen.
Modules can be used on self centrig vises or base rails.

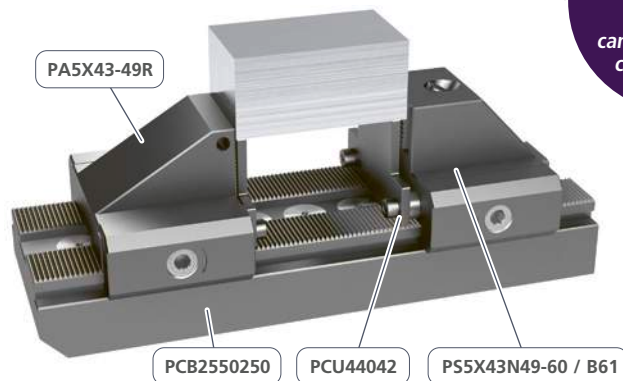
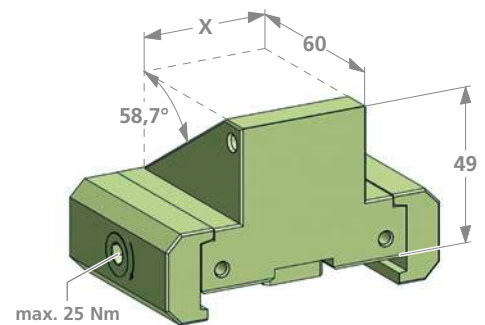

Anschlagmodule ... End module ...



5axes powerCLAMP

für die horizontale und vertikale Bearbeitung
for horizontal and vertical machining

Art. Nr.	kg	X	H
PAND78-34	~1,5	78	34
PAND78-49	~2,1	78	49
PAND94-34	~2,3	94	34
PAND94-49	~2,7	94	49
PAND125-49	~2,7	125	49

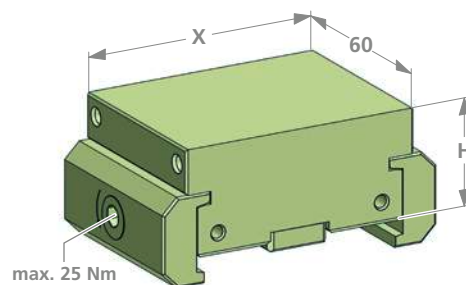

78 mm bis 125 mm breite Anschlagmodule
für die Einzel- und Mehrfachspannung.

78 mm to 125 mm wide end modules for
single and multiple clamping.

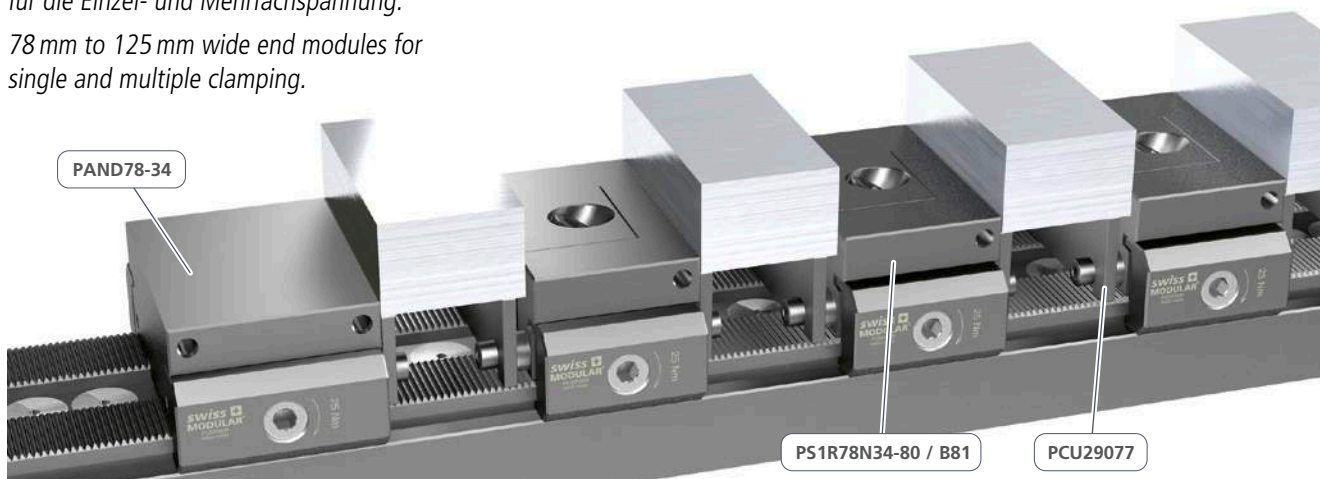

für 5-Achs Bearbeitung
for 5-axis machining

Art. Nr.	kg	X
PA5X94-49F	~1,8	94
PA5X94-49R	~1,8	94
PA5X125-49F	~2,0	125
PA5X125-49R	~2,0	125

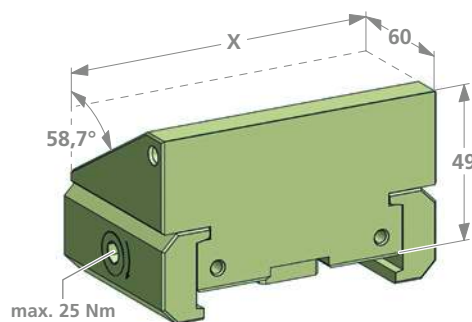

Module
einsetzbar auf
Zentrischspannern
oder Basisschienen.
Modules
can be used on self
centrig vises or
base rails.

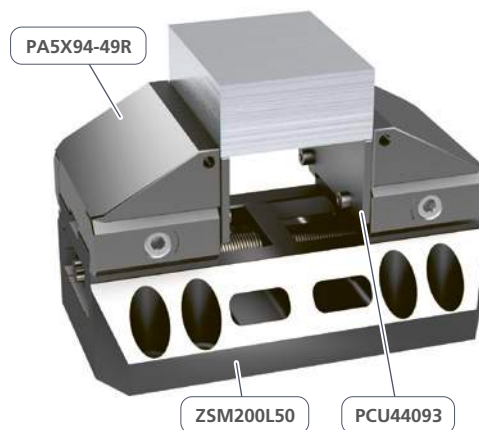
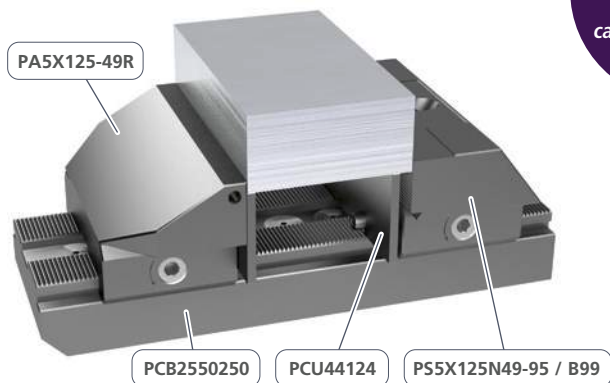

PAND48-34PRG/F-A1

PAND48-49PRG/F-A1

PAND94-34PRG/F-A1

PAND94-49PRG/F-A1

PAND125-49PRG-A1



5axes

powerCLAMP

PAND48-34PRG-A1

1x TH120684

PAND48-34PRF-A1

1x TK140239
 3x PCSP60R
 4x PCSP60L
 5x PCS14
 6x PCGU2049
 7x M6X8ISO7380
 12x M5X10ISO4762

X = 48
 H = 34
 H1 = 15
 kg ~1,1

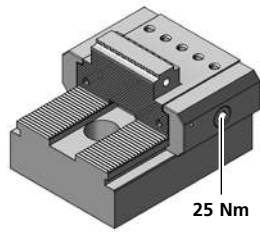

25 Nm

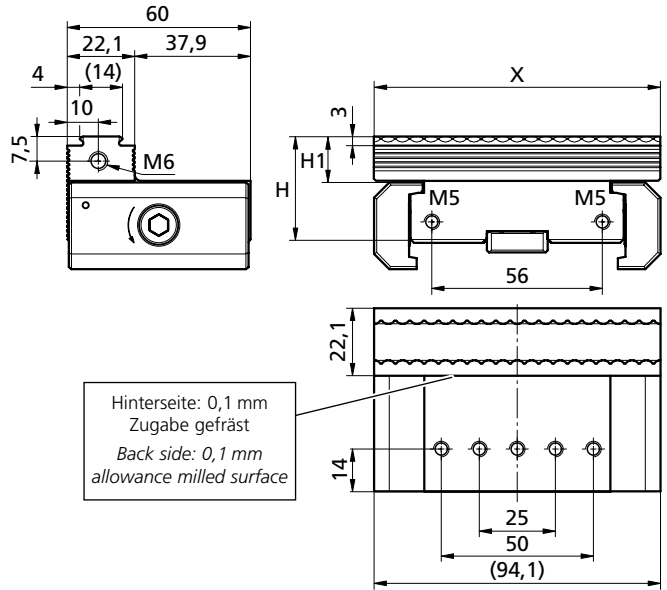

PAND48-49PRG-A1

1x TH120685

PAND48-49PRF-A1

1x TK140597

X = 48
 H = 49
 H1 = 30
 kg ~1,3

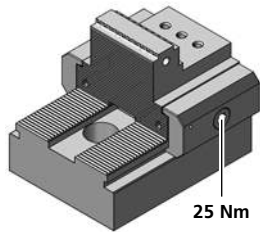

25 Nm

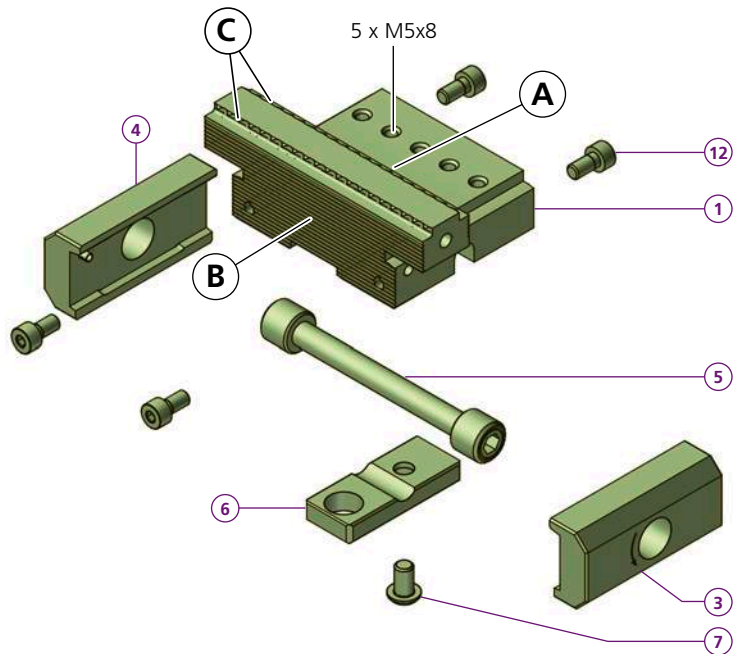

PAND94-34PRG-A1

1x TH120686

PAND94-34PRF-A1

1x TH140185

X = 94
 H = 34
 H1 = 15
 kg ~1,2

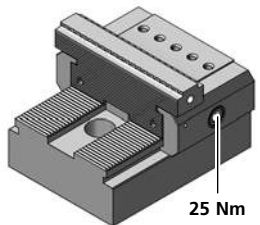

25 Nm

PAND94-49PRG-A1

1x TH120687

PAND94-49PRF-A1

1x TH130754

X = 94
 H = 49
 H1 = 30
 kg ~1,6

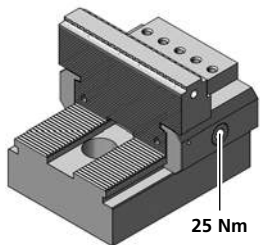

25 Nm

PAND125-49PRG-A1

1x TB160295

X = 125
 H = 49
 H1 = 30
 kg ~1,7

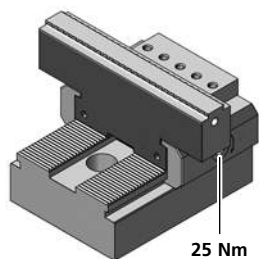

25 Nm

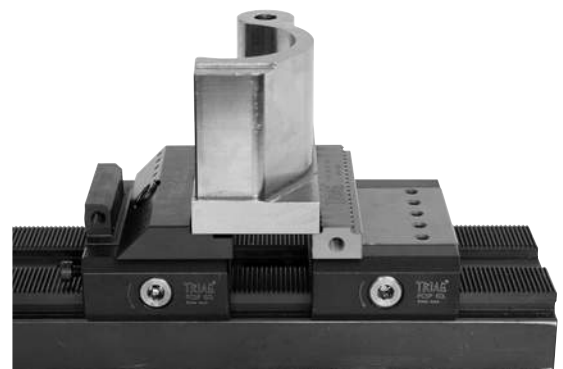

Bestellbeispiel / Ordering example: PAND94-34PRG-A1



X = 125

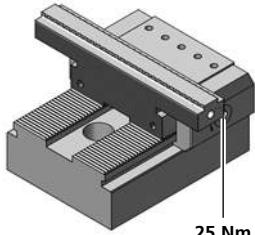

25 Nm

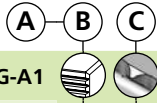

PAND125-34PRG-A1

- ① 1x TB180899
- X = 125
- kg ~1,2

PAND150-34PRG-A1

- ① 1x TB160145
- ③ 1x PCSP50R
- ④ 1x PCSP50L
- ⑤ 1x PCS14
- ⑥ 1x PCGU2049
- ⑦ 1x M6X8ISO7380
- ⑫ 4x M5X10ISO4762
- X = 150
- kg ~1,2

X = 150

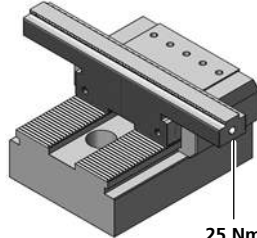

25 Nm

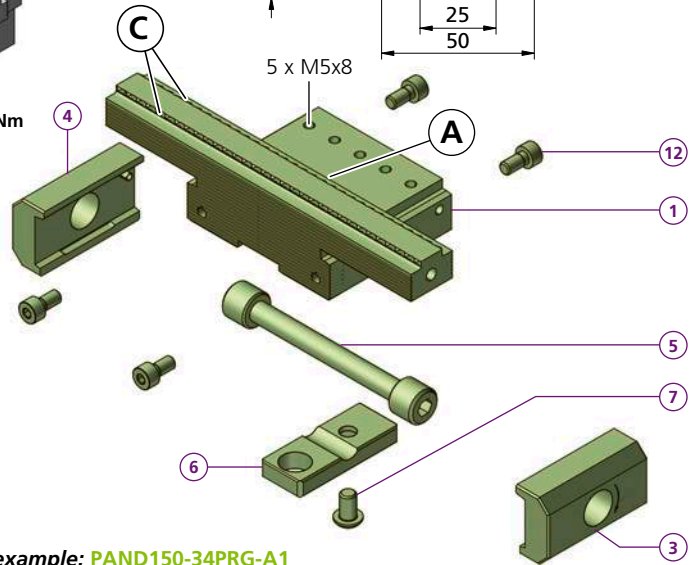
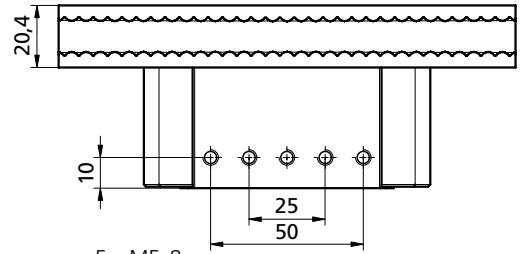
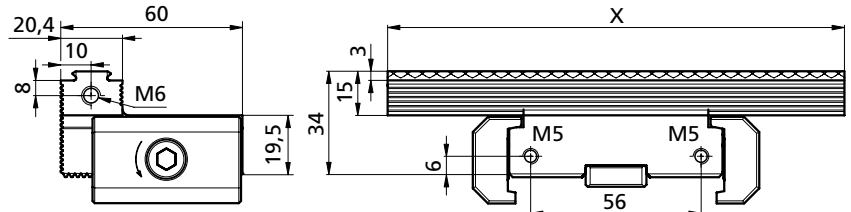

Bestellbeispiel / Ordering example: PAND150-34PRG-A1

H = 34

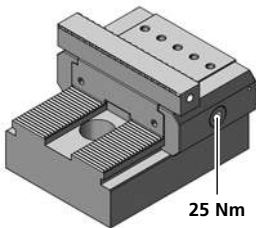

25 Nm



PAND94-34PRGV

- ① 1x TH171180
- ③ 1x PCSP60R
- ④ 1x PCSP60L
- ⑤ 1x PCS14
- ⑥ 1x PCGU2049
- ⑦ 1x M6X8ISO7380
- ⑫ 4x M5X10ISO4762
- H = 34
- H1 = 15
- A = 17,5
- kg ~1,2

PAND94-49PRGV

- ① 1x TH171179
- H = 49
- H1 = 30
- A = 17
- kg ~1,6

H = 49

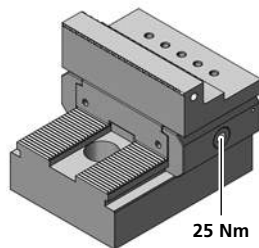

25 Nm

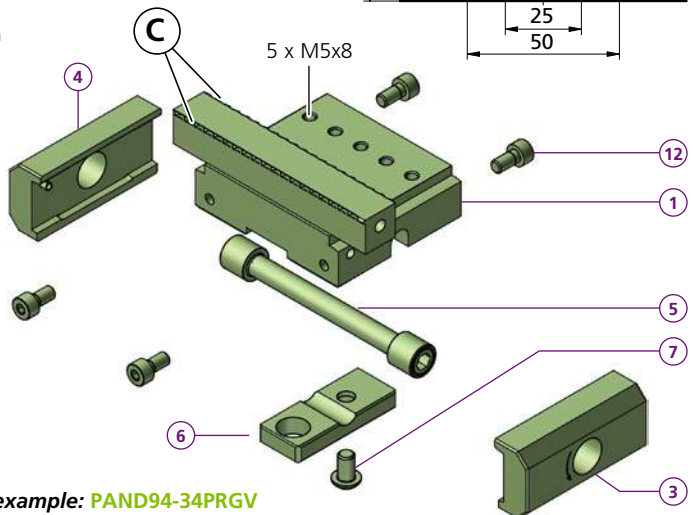
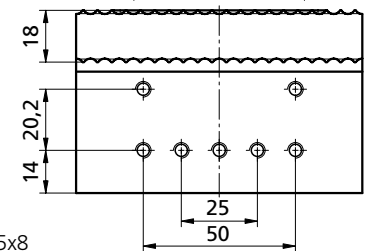
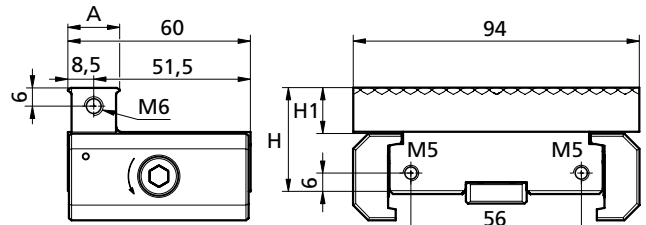





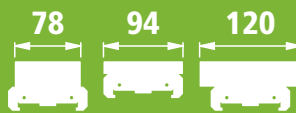

Bestellbeispiel / Ordering example: PAND94-34PRGV

Anschlagmodule zum Prägen ... End modules for stamping ...



**5axes
powerCLAMP**

für die horizontale und vertikale Bearbeitung
for horizontal and vertical machining

Art. Nr.		kg	Z	H
PAND78-34UPRG	 	~1,2	60	34
PAND78-49UPRG	 	~1,5	60	49
PAND78-34X50UPRG	 	~1,0	50	34

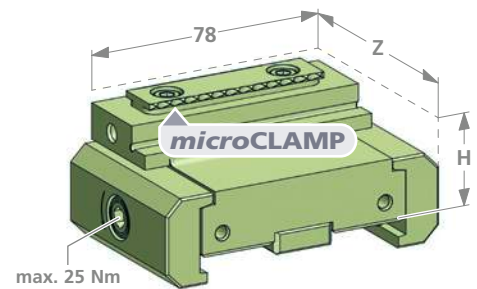

Art. Nr.		kg
PAND120-49UPRG	 	~1,8

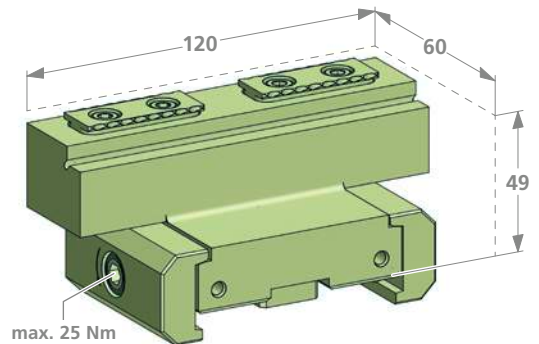

Art. Nr.		kg
PANF94-34PRGM8	 	~1,5

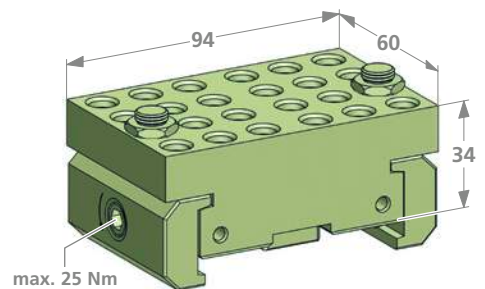

Module einsetzbar auf Zentrischspannern oder Basisschienen.

Modules can be used on self centrig vises or base rails.

Der Einsatz dieser Spannmodule erweitert die Spannmöglichkeiten für runde und unförmige Werkstücke erheblich.

The use of these clamping modules expands the clamping possibilities for round and bulky workpieces considerably.

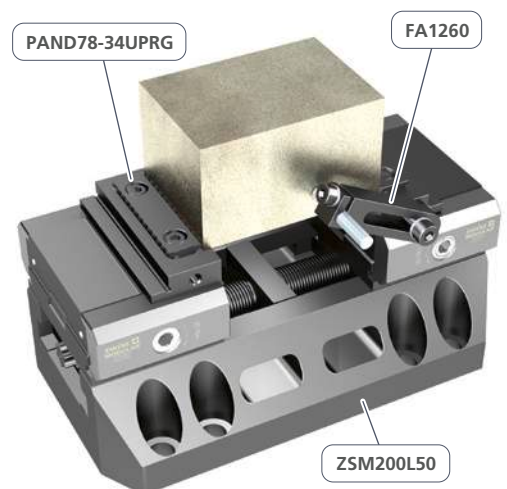
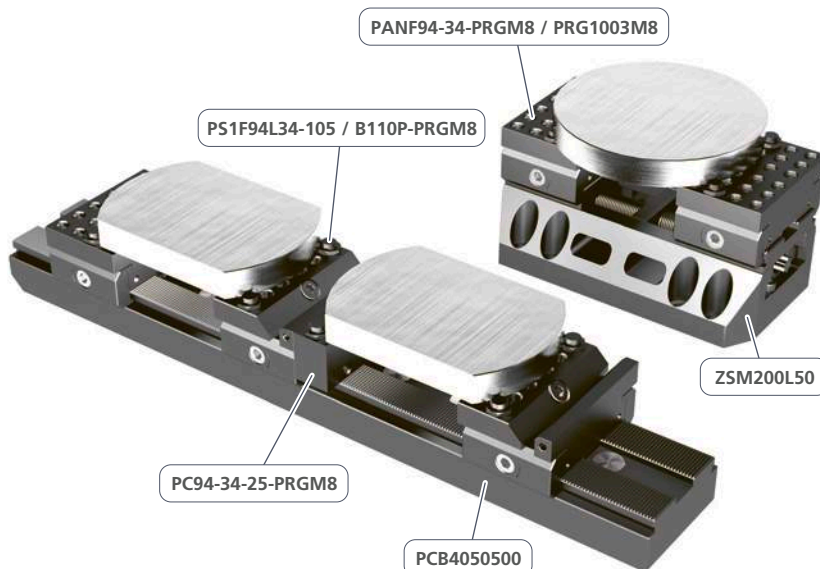

Bei knapp gespannten Werkstücken sind direkt-Prägebacken die ideale Wahl zum spannen.

For tight clamped workpieces, direct stamping jaws are the ideal choice for clamping.

Rohlingsmodule
Blank module

PT-F80-30X60
PT-F80-30X60NS
PT-F80-30X30NS

PT-F61-25X60
PT-F61-25X50
PT-F61-25X30

5axes
powerCLAMP

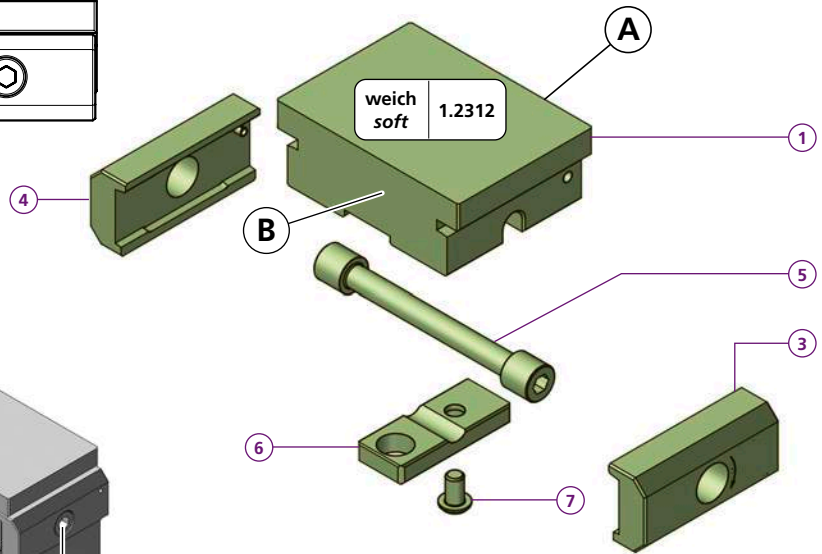
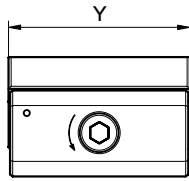
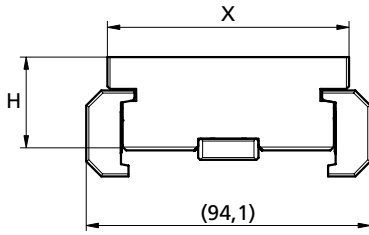

PT-F80-30X60

- 1 1x TF140637
- 3 1x PCSP60R
- 4 1x PCSP60L
- 5 1x PCS14
- 6 1x PCGU2049
- 7 1x M6X8ISO7380

X = 80
H = 30
Y = 60
kg ~1,4

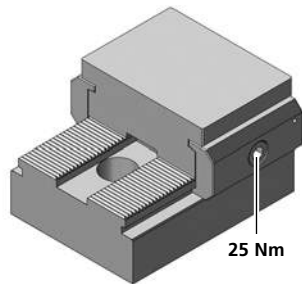

PT-F80-30X60NS

NS = Rohlingsmodul freie Positionierung ohne Verzahnung
Carrier module without positioning serration for free positioning

- 1 1x TF140635
- 3 1x PCSP60R
- 4 1x PCSP60L
- 5 1x PCS14
- 6 1x PCGU2049
- 7 1x M6X8ISO7380

X = 80
H = 30
Y = 60
kg ~1,4

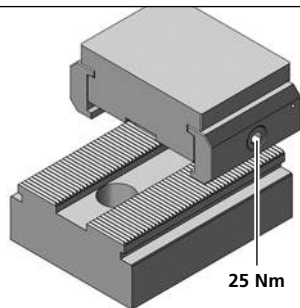

PT-F80-30X30NS

NS = Rohlingsmodul freie Positionierung ohne Verzahnung
Carrier module without positioning serration for free positioning

- 1 1x TF140749
- 3 1x PCSP30R
- 4 1x PCSP30L
- 5 1x PCS14
- 6 1x PCGU2030
- 7 1x M6X8ISO7380

X = 80
H = 30
Y = 30
kg ~0,7

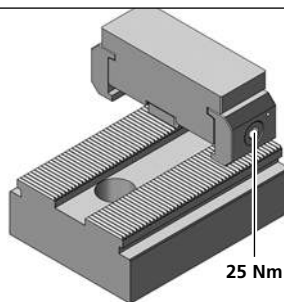

PT-F61-25X60

- 1 1x TF140638
- 3 1x PCSP60R
- 4 1x PCSP60L
- 5 1x PCS14
- 6 1x PCGU2049
- 7 1x M6X8ISO7380

X = 61
H = 25
Y = 60
kg ~1,1

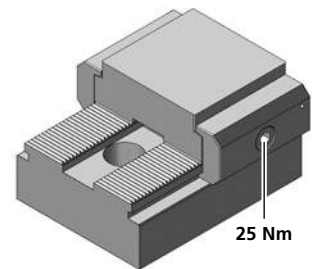

PT-F61-25X50

- 1 1x TF140750
- 3 1x PCSP50R
- 4 1x PCSP50L
- 5 1x PCS14
- 6 1x PCGU2049
- 7 1x M6X8ISO7380

X = 61
H = 25
Y = 50
kg ~1,0

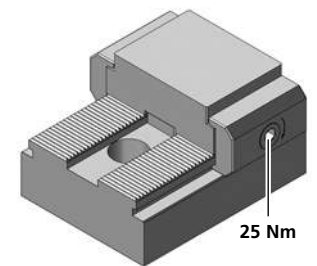

PT-F61-25X30

- 1 1x TF140636
- 3 1x PCSP30R
- 4 1x PCSP30L
- 5 1x PCS14
- 6 1x PCGU2049
- 7 1x M6X8ISO7380

X = 61
H = 25
Y = 30
kg ~0,6

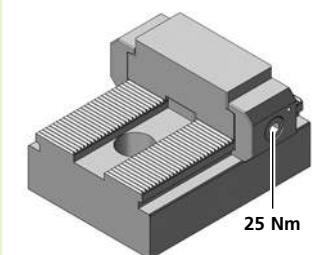

Bestellbeispiel / Ordering example: **PT-F80-30X60**

PR94-49SET

PR94-39-50SET

Rohlingsmodule
Blank module

PR125-49SETALU
PT-F132-34RDSET

PR150-49SET
PR125-49SET

5axes
powerCLAMP

A B C

- PR94-49SET**
- 1 1x PR94-49
 - 3 1x PCSP50R
 - 4 1x PCSP50L
 - 5 1x PCS14
 - 6 1x PCGU2049
 - 7 1x M6X8ISO7380
- X = 94
H = 49
Y = 60,4
kg ~2,3

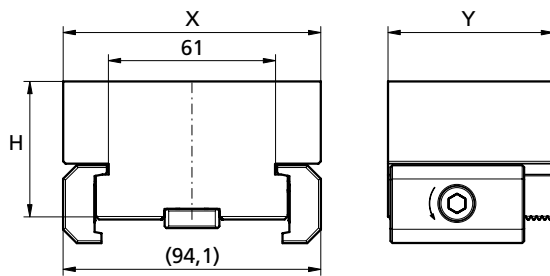
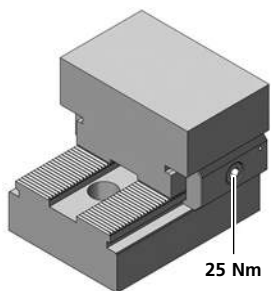

- PR94-39-50SET**
- 1 1x PR94-39-50
- X = 94
H = 39
Y = 50,4
kg ~1,6

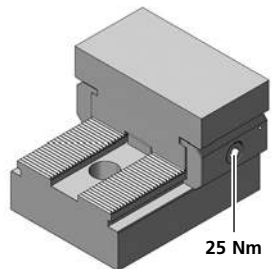

- PR125-49SET**
- 1 1x PR125-49
- X = 125
H = 49
Y = 60,4
kg ~2,7

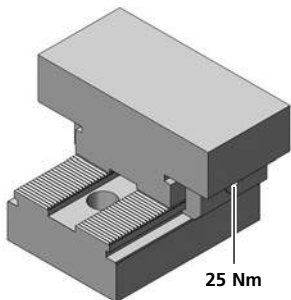

- PR125-49SETALU**
- 1 1x *PR125-49ALU
- X = 125
H = 49
Y = 60,4
kg ~0,83

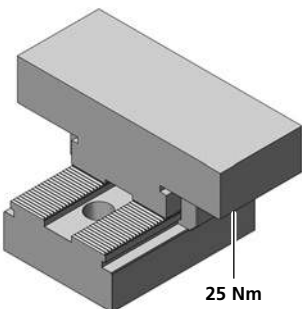

- PR150-49SET**
- 1 1x PR150-49
- X = 150
H = 49
Y = 60,4
kg ~3,1

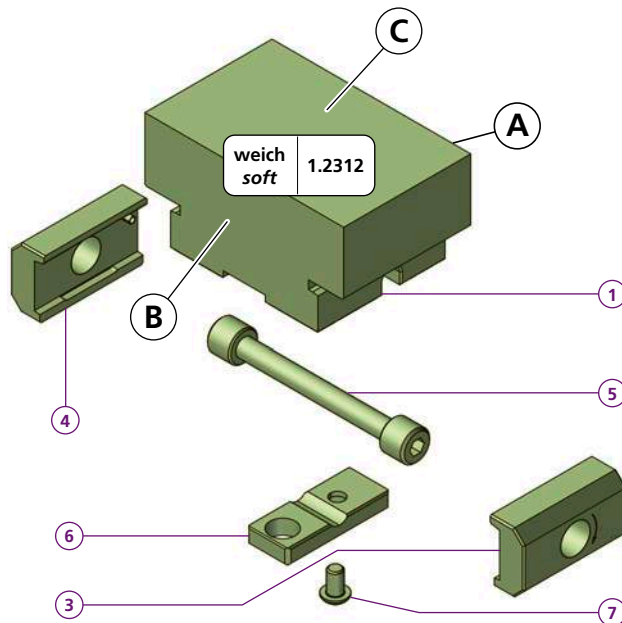

* ALU = ENAW-7022 Bestellbeispiel / Ordering example: PR94-49SET

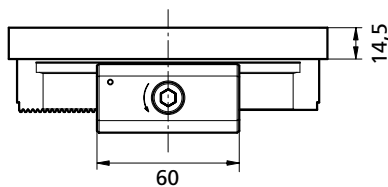
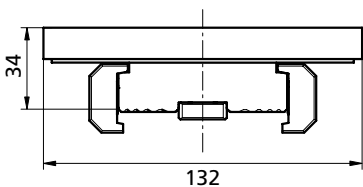

- PT-F132-34RDSET**
- 1 1x PT-F132-34RD
 - 3 1x PCSP60R
 - 4 1x PCSP60L
 - 5 1x PCS14
 - 6 1x PCGU2059
 - 7 1x M6X8ISO7380
- kg ~3,1

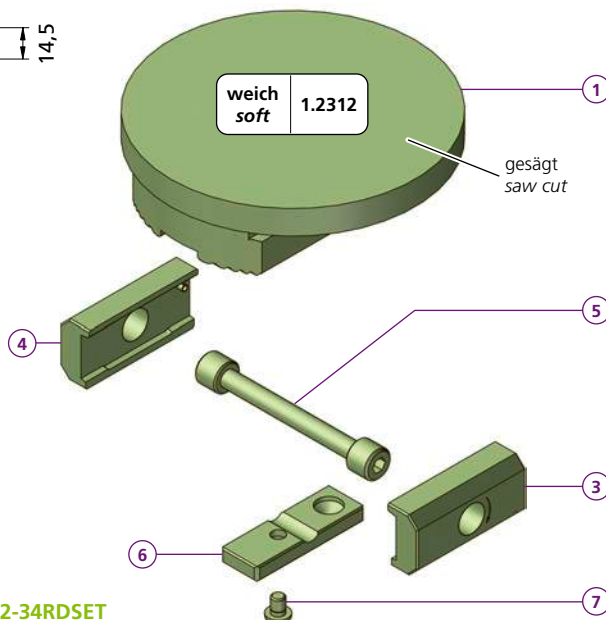
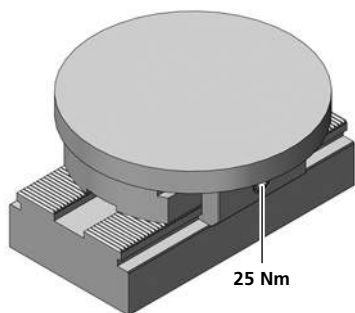

Bestellbeispiel / Ordering example: PT-F132-34RDSET

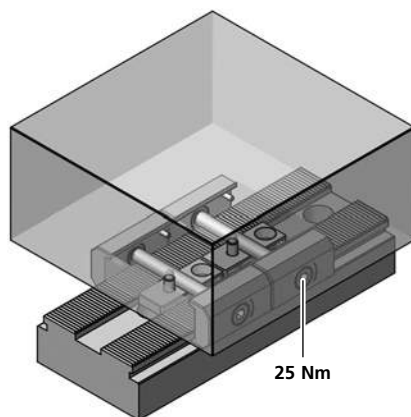
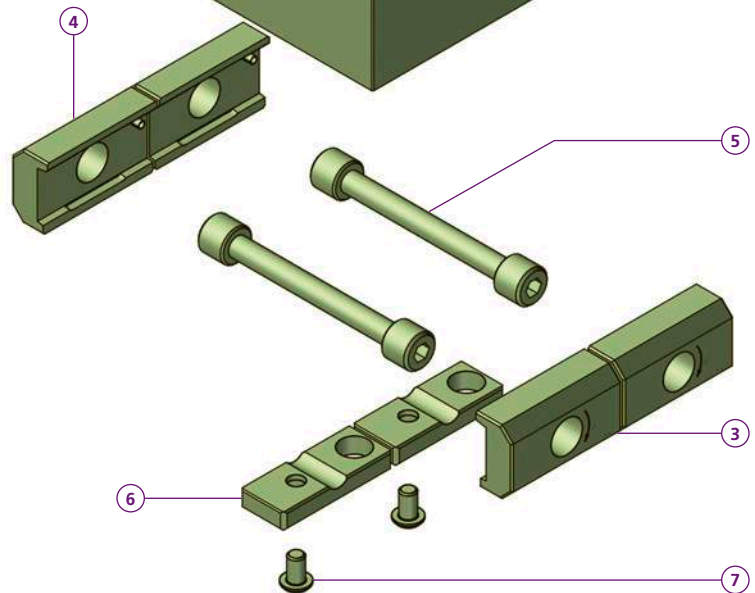
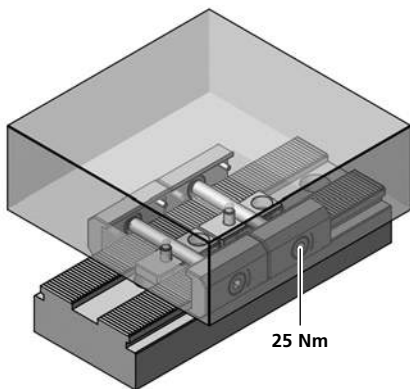
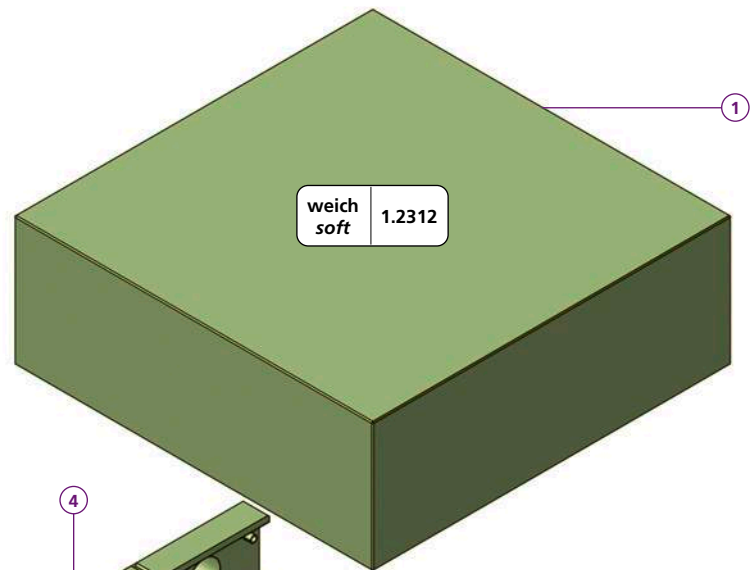
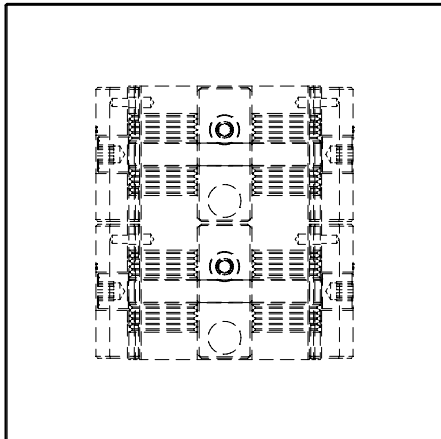
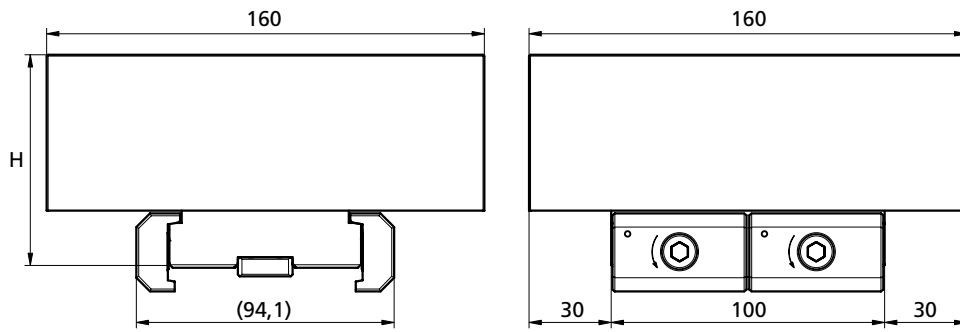

PTX160-57S	
1	1x TH130539
3	2x PCSP50R
4	2x PCSP50L
5	2x PCS14
6	2x PCGU2049
7	2x M6X8ISO7380
H	= 57
kg	~9

PTX160-77S	
1	1x TH130723
H	= 77
kg	~13

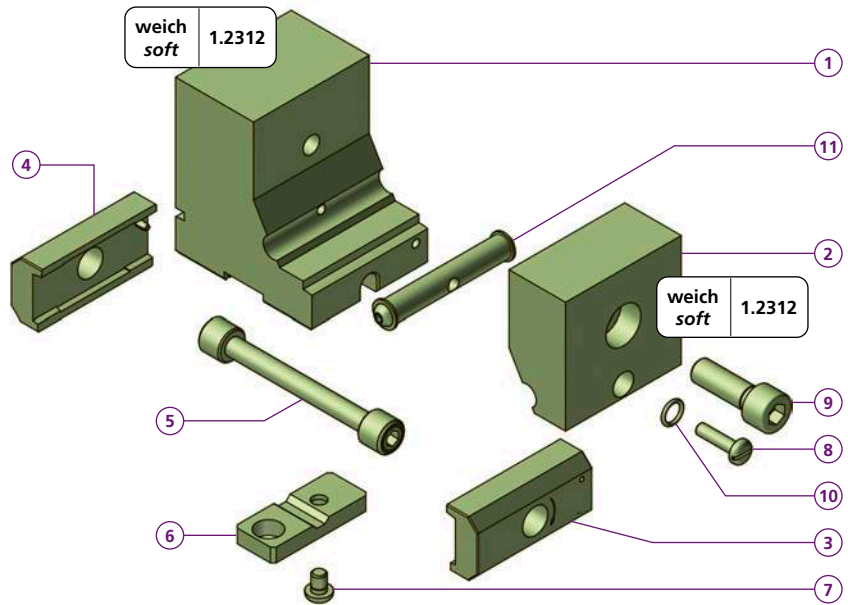
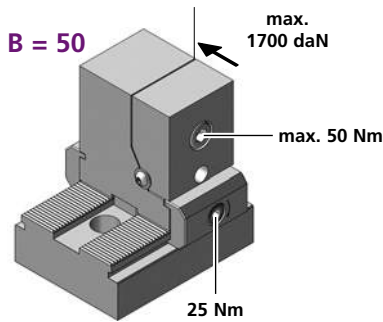
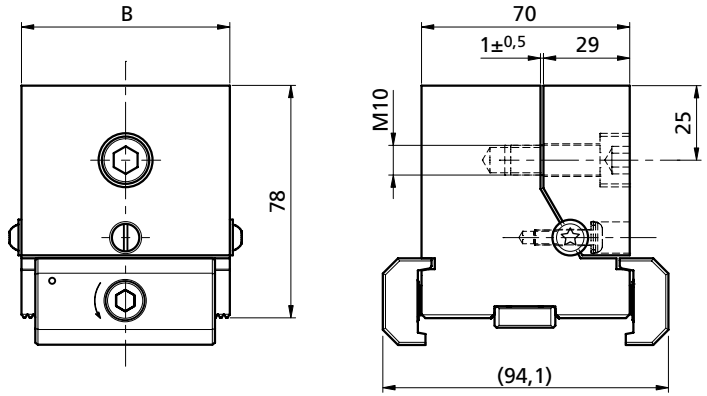
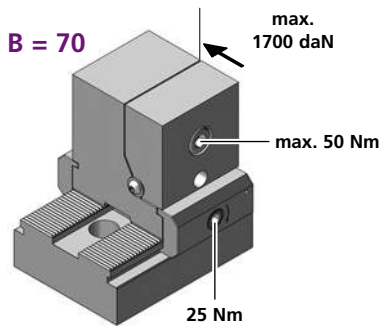

PS1X70L78ST

- ① 1x PRS7078AST
- ② 1x PRS7078SST
- ③ 1x PCSP60R
- ④ 1x PCSP60L
- ⑤ 1x PCS14
- ⑥ 1x PCGU2049
- ⑦ 1x M6X8ISO7380
- ⑧ 1x M5X20BN1362
- ⑨ 1x M10X30ISO4762
- ⑩ 1x OR Ø 8x1,5
- ⑪ 1x PRS7078G
- B = 70
- kg ~3,2

PS1X50L78ST

- ① 1x PRS5078AST
- ② 1x PRS5078SST
- ③ 1x PCSP50R
- ④ 1x PCSP50L
- ⑪ 1x PRS5078G
- B = 50
- kg ~2,3

PRS70L78ST

- ① 1x PRS7078AST
- ② 1x PRS7078SST
- ⑪ 1x PRS7078G
- B = 70
- kg ~2,8

PRS50L78ST

- ① 1x PRS5078AST
- ② 1x PRS5078SST
- ⑪ 1x PRS5078G
- B = 50
- kg ~2,0



Drehmoment Torque		Spannkraft Workholding force		
Nm	(lb-ft)	~daN	~(lb)	~t
10	7,4	= 400	880	0,4
20	14,8	= 800	1'760	0,8
30	22,2	= 1'200	2'650	1,2
40	29,6	= 1'600	3'530	1,6

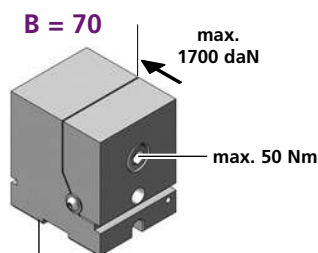

PRS = Rohlingsmodul ohne Spannpratzen
Blank module side clamp



Spannbacken Rohling auf Kundenwunsch angepasst
Jaw blank machined to customer specification

Bestellbeispiel / Ordering example: **PS1X70L78ST**



Anschlagmodul für runde Werkstücke
Endmodule for round workpieces

Art. Nr.		Ø	X	kg
PAND30-34RV12-35		12 – 35	30	~1,1
PAND61-34RV35-80		35 – 80	61	~1,26

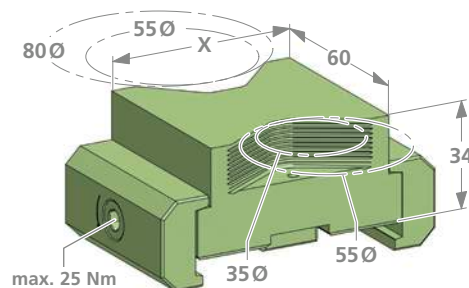
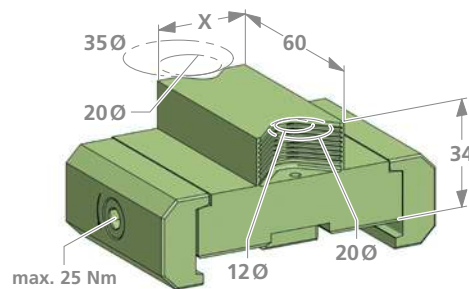

Runde Werkstücke, die einen Durchmesserbereich von 12 – 80 mm abdecken, können auf vielfältige Art gespannt werden.

Round workpieces covering a diameter range from 12 - 80 mm can be clamped in a variety of ways.

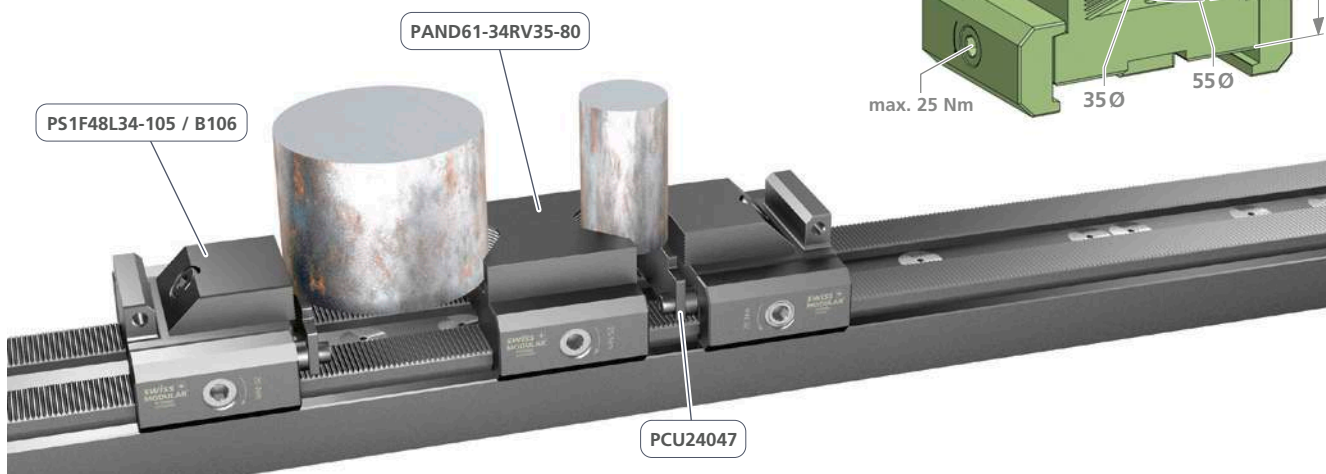

Module einsetzbar auf Zentrischspannern oder Basisschienen.
Modules can be used on self centrig vises or base rails.

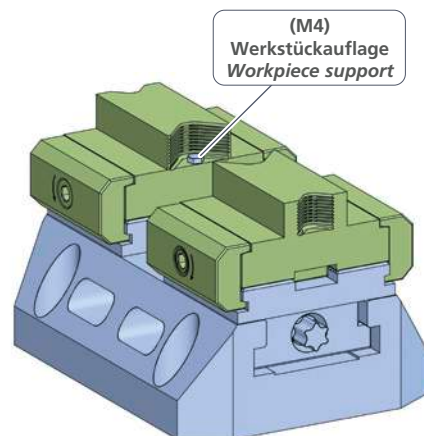

Drehmoment Torque		Spannkraft Workholding force		
Nm	(lb-ft)	~daN	~(lb)	~t
10	7,4	= 200	440	0,2
20	14,8	= 500	1'102	0,5
30	22,2	= 1'000	2'204	1,0
40	29,6	= 1'300	2'866	1,3
50	37,0	= 1'600	3'527	1,6

NUSS3/8"TX30E14

WICHTIG!
Bitte separat bestellen
IMPORTANT!
Please order separately



Dreibackenfutter
Three jaw chuck

PS3X80L75BSET
PS3X100L82BSET
PS3X125L87BSET

5axes
powerCLAMP

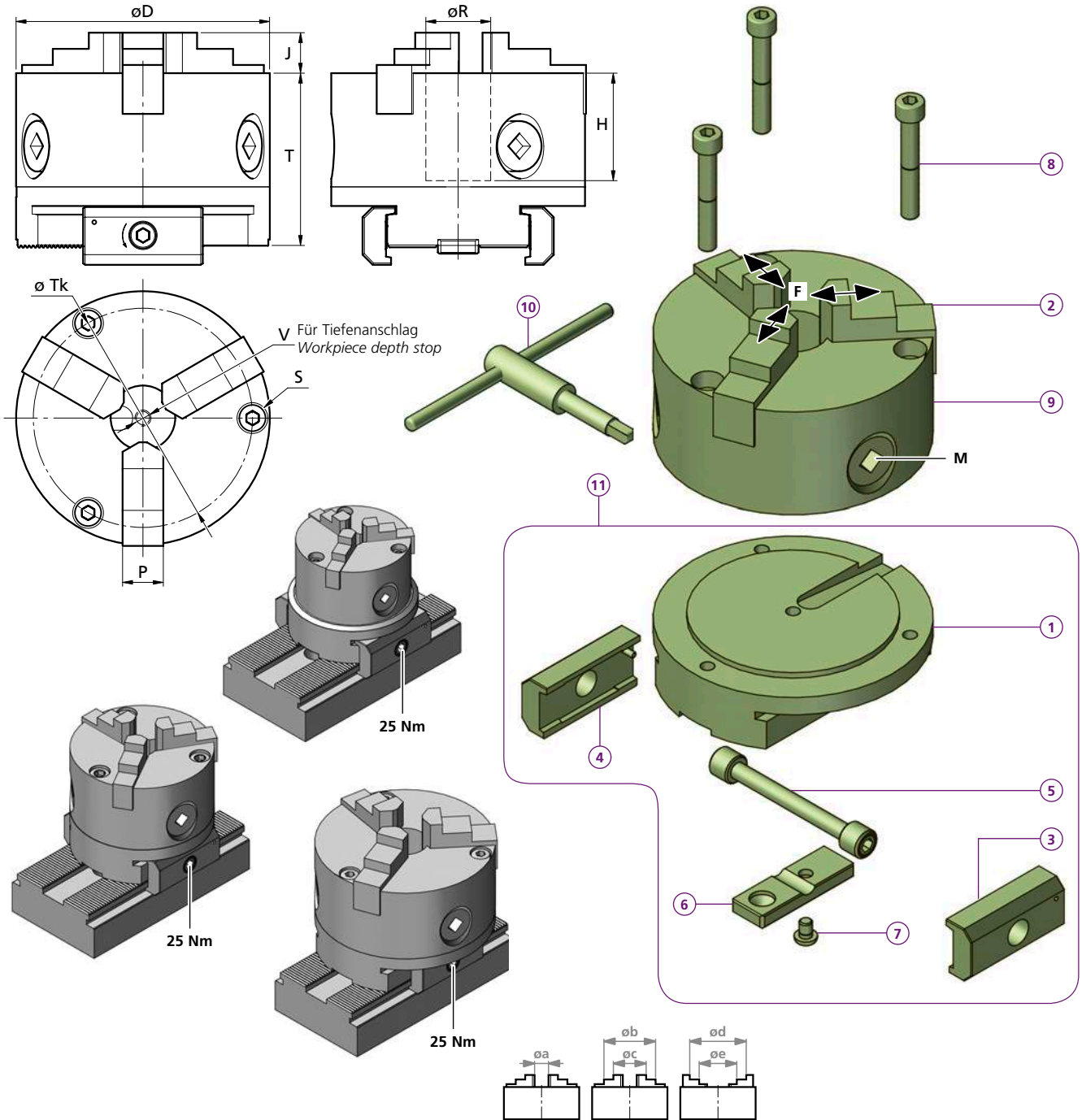

	D	J	T	R	H	P	V	a mm	b mm	c mm	d mm	e mm	M (max.)	F (max.)	ø Tk	S
PS3X80L75BSET	80	13	75	15	42,5	10	M6	3...27	48...73	23...48	52...76	27...51	28 Nm	1300 daN	67	M6
PS3X100L82BSET	100	17	82	20	49,5	14	M8	3...39	58...94	24...60	64...100	30...66	38 Nm	1600 daN	83	M8
PS3X125L87BSET	125	19	87	32	55	16	M8	3...49	70...116	30...75	83...125	38...84	55 Nm	2600 daN	108	M8

- PS3X80L75BSET**
- 1 1x TW090013_01
 - 2 2x 3 Stk. / pcs
 - 3 1x PCSP60R
 - 4 1x PCSP60L
 - 5 1x PCS14
 - 6 1x PCGU2059
 - 7 1x M6X8ISO7380
 - 8 3x M6X45ISO4762
 - 9 1x 243809.0083220
 - 10 1x 243864.0080000
 - 11 PTX80-30
- kg ~2,8

- PS3X100L82BSET**
- 1 1x TW090012_01
 - 2 2x 3 Stk. / pcs
 - 8 3x M8X50ISO4762
 - 9 1x 243809.0103220
 - 10 1x 243864.0100000
 - 11 PTX100-30
- kg ~4,3

- PS3X125L87BSET**
- 1 1x TW080027_01
 - 2 2x 3 Stk. / pcs
 - 8 3x M8X55ISO4762
 - 9 1x 243809.0123220
 - 10 1x 243864.0120000
 - 11 PTX125-29
- kg ~6,3

Ø 80
100
125

243849.0083200	243850.0083200	*243834.0083300 *243834.0103300 *243834.0123300
243849.0103200	243850.0103200	
243849.0123200	243850.0123200	

3x
Ø 3 - 49

3x
Ø 38 - 125

3x
*Weich
Soft
16MnCr5

Bestellbeispiel / Ordering example: **PS3X125L87BSET**

Separat bestellen / Order separately

Spannzangenmodule Collet modules

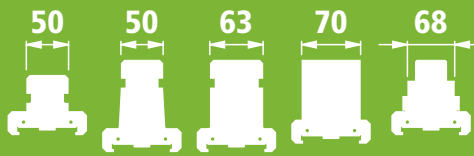

**5axes
powerCLAMP**

für die horizontale und vertikale Bearbeitung
for horizontal and vertical machining

Art. Nr.	kg	Ø	Y	H
PS1X50N62-ER32	~1,3	2-22	60	62
PS1X50N100-ER32	~2,2	2-22	60	100
PS1X63N100-ER40	~2,3	3-29	80	100

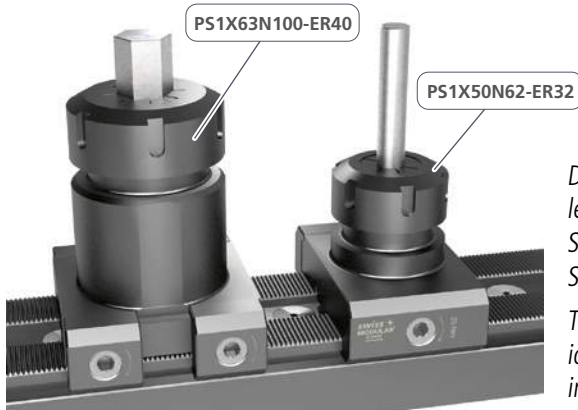
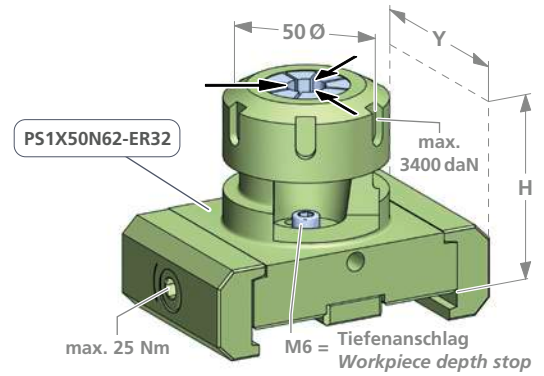

Diese Spannzangenmodule ermöglichen das ideale Spannen und Bearbeiten von Stangenmaterial.

These collet modules enable ideal clamping and machining of bar material.

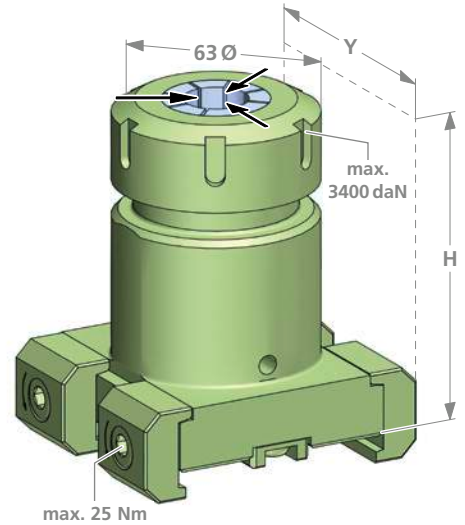

Art. Nr.	kg	Ø
PS1X50N70H-ER32-NS	~2,98	2-22

Die seitlichen Spannpratzen können um 90° gedreht werden, dadurch kann das Spannzangenmodul auch quer zur Schiene platziert werden.

The side clamps can be turned by 90°, the module can therefore be placed crosswise to the rail.



**NS = freie Positionierung ohne Verzahnung
free positioning without interlocking**

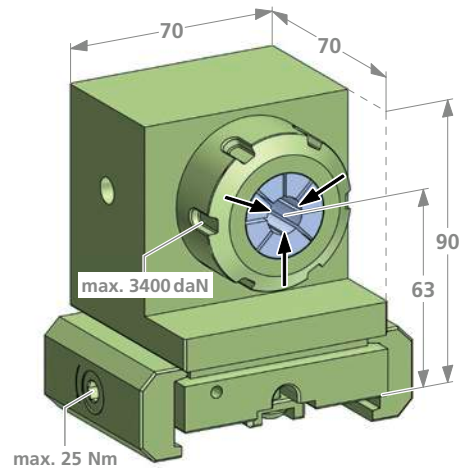

Art. Nr.	kg	Ø	M
PS1X68N80-W20	~1,8	0,5-20	M37,6x3

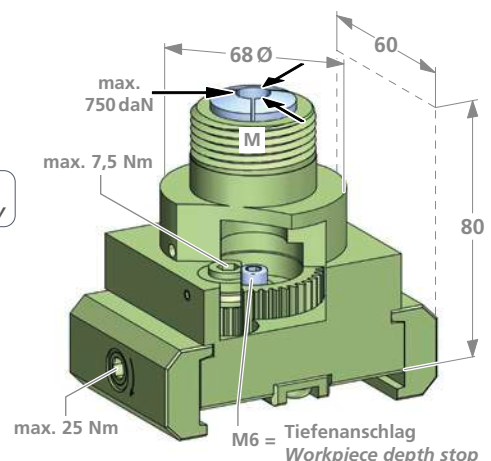
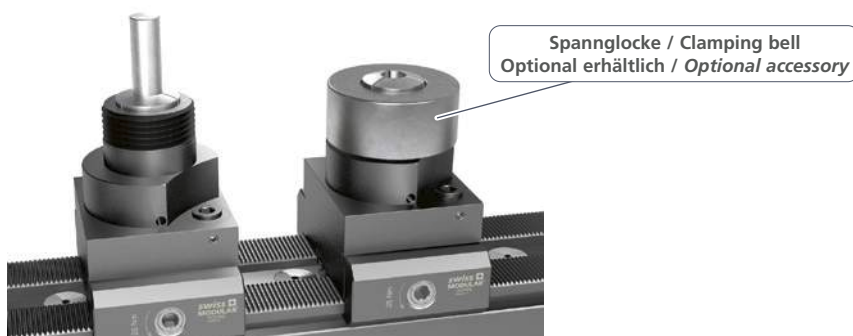

PS1F-KLD1
PS1F-KLD1NS

powerCLAMP

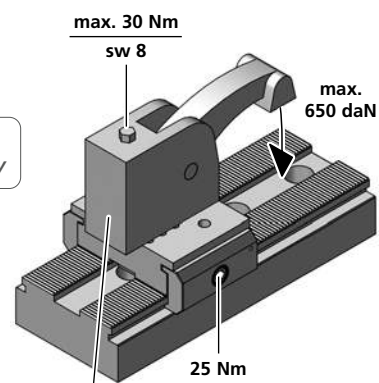
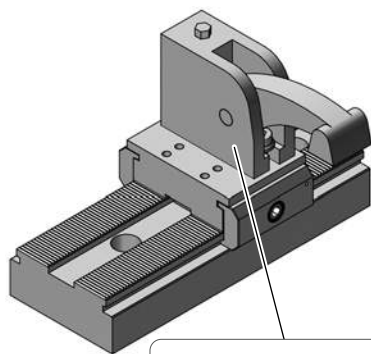
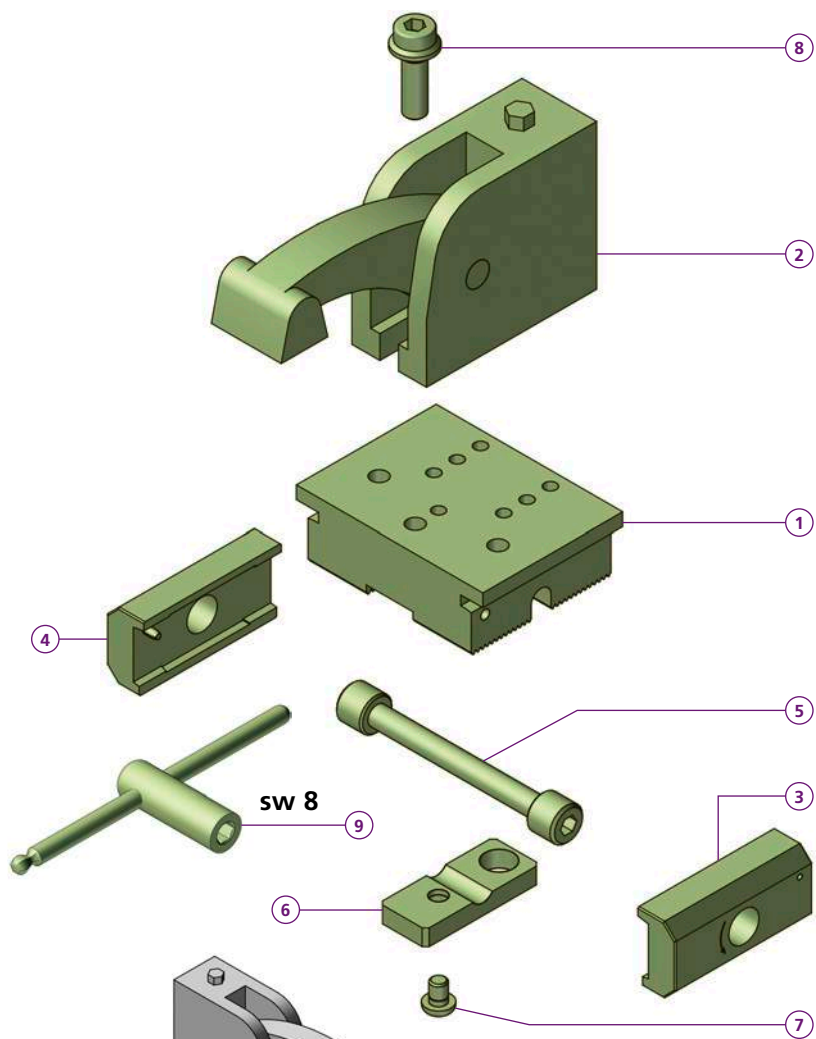
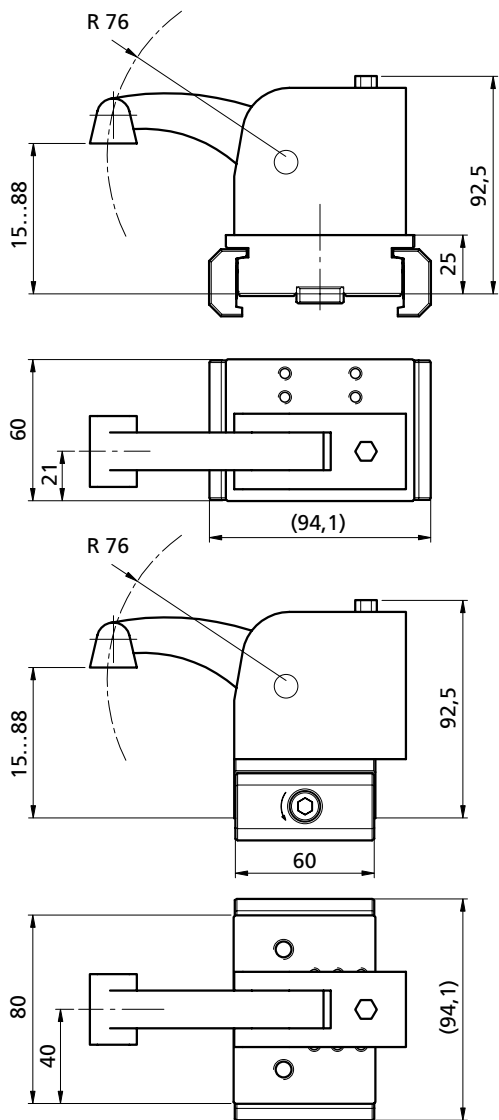

NS = Trägermodul freie Positionierung ohne Verzahnung
Carrier module without positioning serration for free positioning

PS1F-KLD1	
1	1x PCTMV1F
2	1x 07-020
3	1x PCSP60R
4	1x PCSP60L
5	1x PCS14
6	1x PCGU2049
7	1x M6X8ISO7380
8	1x M8x25 TW080012-02
9	1x 07-180
kg	~2,1
PS1F-KLD1NS	
2	1x PCTMV1FNS
kg	~2,1

Bestellbeispiel / Ordering example: **PS1F-KLD1NS**

Plattenspanner / Plate clamping modul PS1F20L35BV1
Trägermodul für Micro Zentrischspanner PS1F20L35BV1NS
Support module for micro self centering vise PTX-MCZ40L30 powerCLAMP

PS1F20L35BV1

- ① 1x PCTMV1F
- ② 1x MV1F20L35BV1
- ③ 1x PCSP60R
- ④ 1x PCSP60L
- ⑤ 1x PCS14
- ⑥ 1x PCGU2049
- ⑦ 1x M6X8ISO7380

kg ~1,4

PS1F20L35BV1NS

- ① 1x PCTMV1FNS

kg ~1,4

NS = Trägermodul freie Positionierung ohne Verzahnung
Carrier module without positioning serration for free positioning

microCLAMP p. 177

max. 920 daN max. 15 Nm

25 Nm

PTX-MCZ40L30

- ① 1x ZB200681
- ② 1x TB200682
- ③ 1x PCSP60R
- ④ 1x PCSP60L
- ⑤ 1x PCS14
- ⑥ 1x PCGU2049
- ⑦ 1x TN100008

kg ~0,94

triCENTRO p. 116

Nach Ihren Bedürfnissen können die Micro Zentrischspanner ausgewählt werden.
The micro self centering vise can be selected according to your needs.

25 Nm

Bestellbeispiel / Ordering example: **PS1F20L35BV1**

Magnetspannplatte

Magnetic chuck

PS1X150L60-250MAG11

powerCLAMP

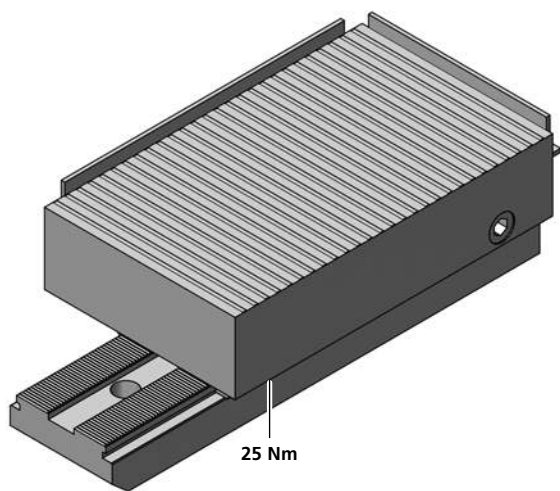
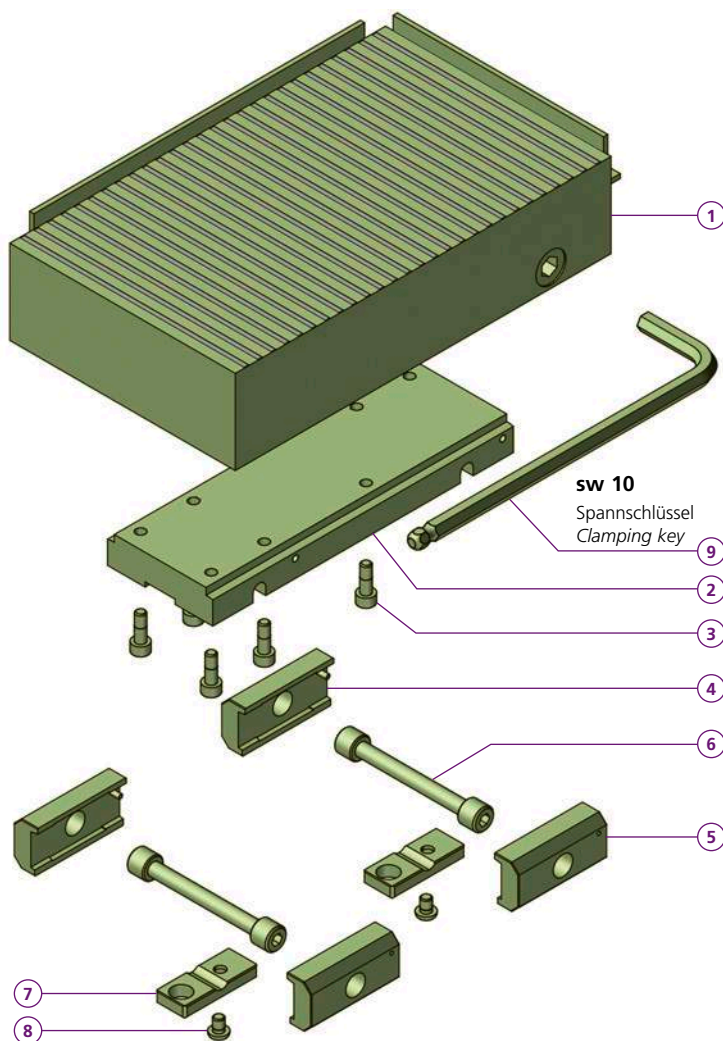
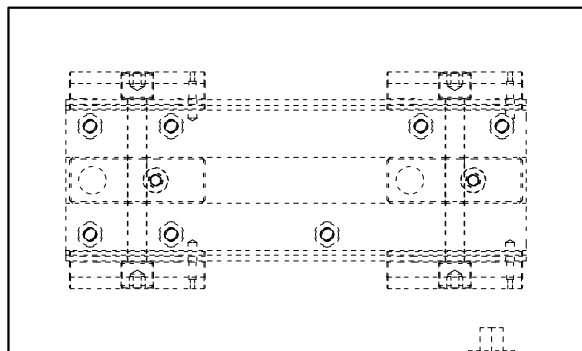
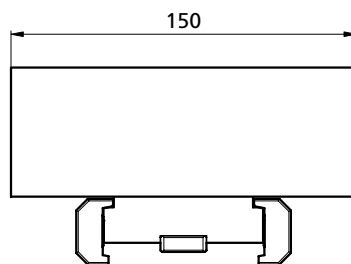
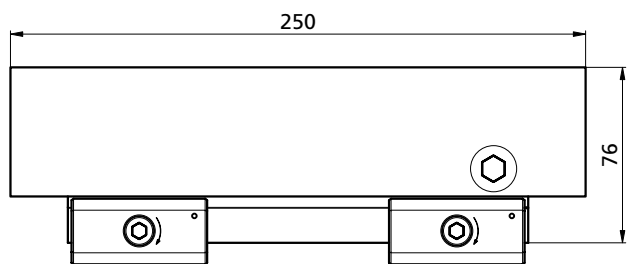

PS1X150L60-250MAG11

- ① 1x XNeomill 250x150
- ② 1x TL110010-01
- ③ 7x MS60
- ④ 2x PCSP60L
- ⑤ 2x PCSP60R
- ⑥ 2x PCS14
- ⑦ 2x PCGU2049
- ⑧ 2x M6X8ISO7380
- ⑨ 1x ISL10 DIN 911L

kg ~19,5

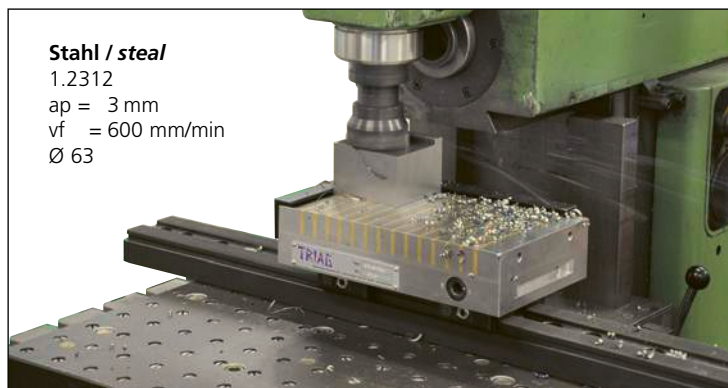

Stahl / steel
 1.2312
 ap = 3 mm
 vf = 600 mm/min
 Ø 63

max. Haltekraft / max. holding force = 120 N/cm²

- Werkstücke ab 26 mm Länge und 6 mm Stärke werden optimal gespannt
- Workpieces from 26 mm length and 6mm thickness will be optimally hold

Bestellbeispiel / Ordering example: **PS1X150L60-250MAG11**

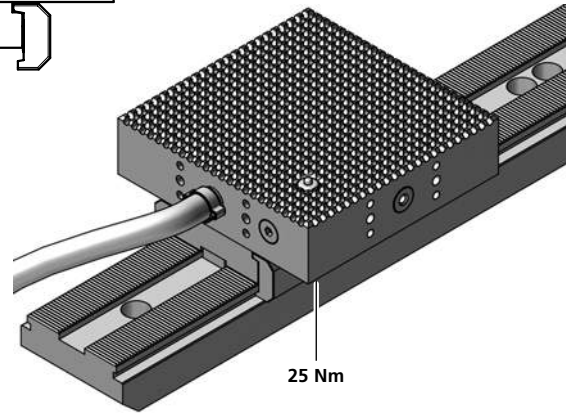
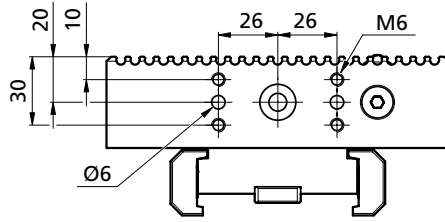
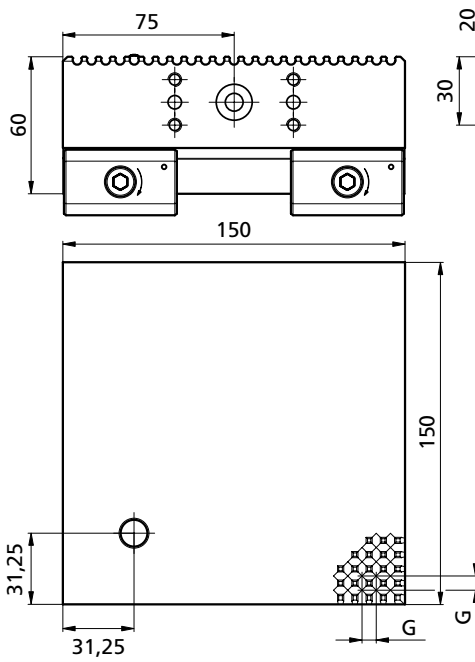

trivaCLAMP p. 318

Mehr Informationen siehe Vacuum
For more information check the vacuum workholding

Bestellbeispiel / Ordering example: PS1X150L60-VAC

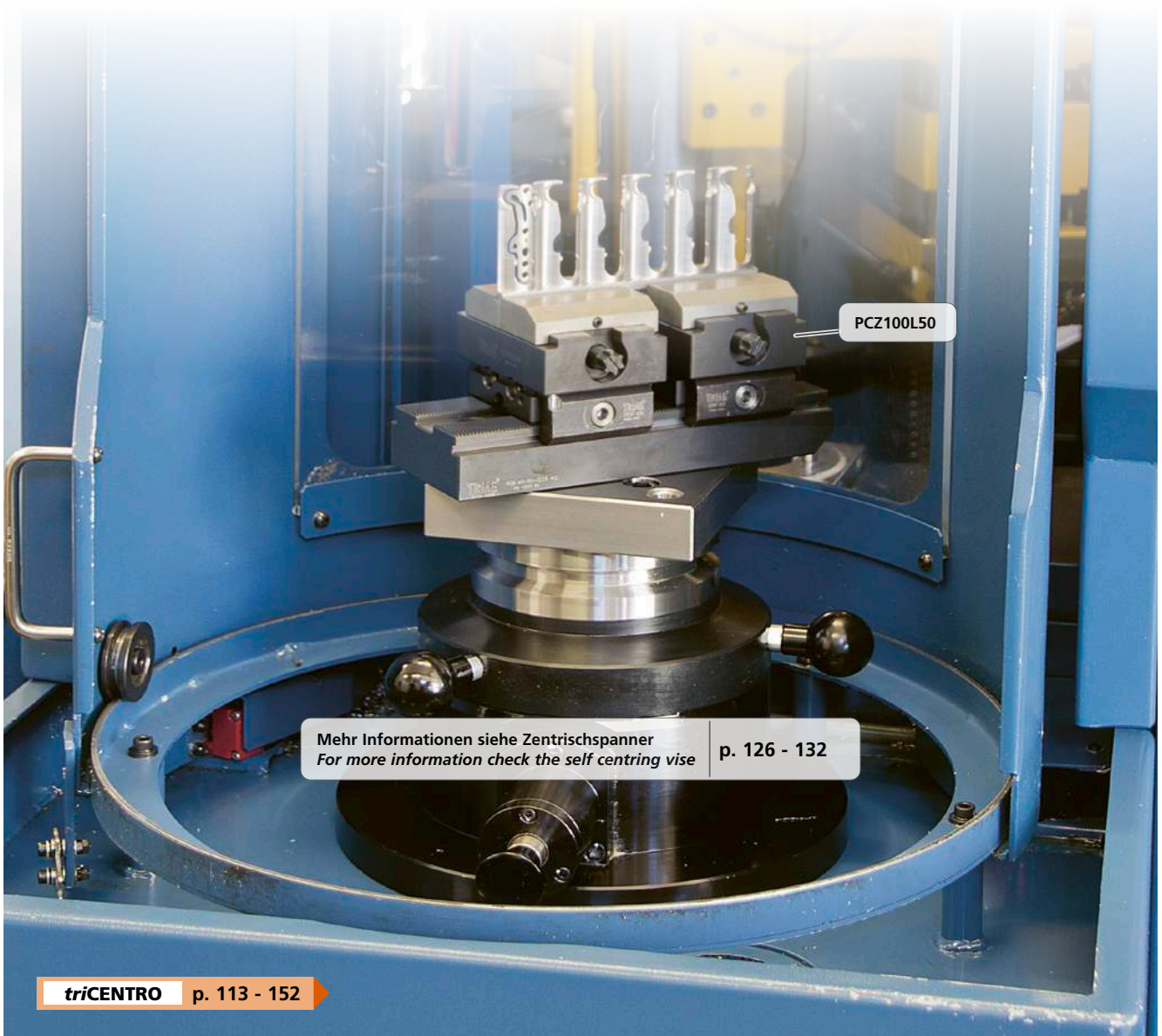

PCZ100L50

Mehr Informationen siehe Zentrischspanner
For more information check the self centring vise p. 126 - 132

triCENTRO p. 113 - 152

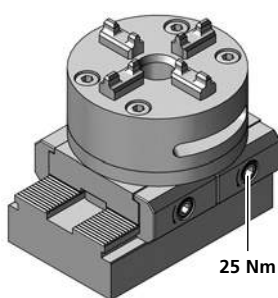
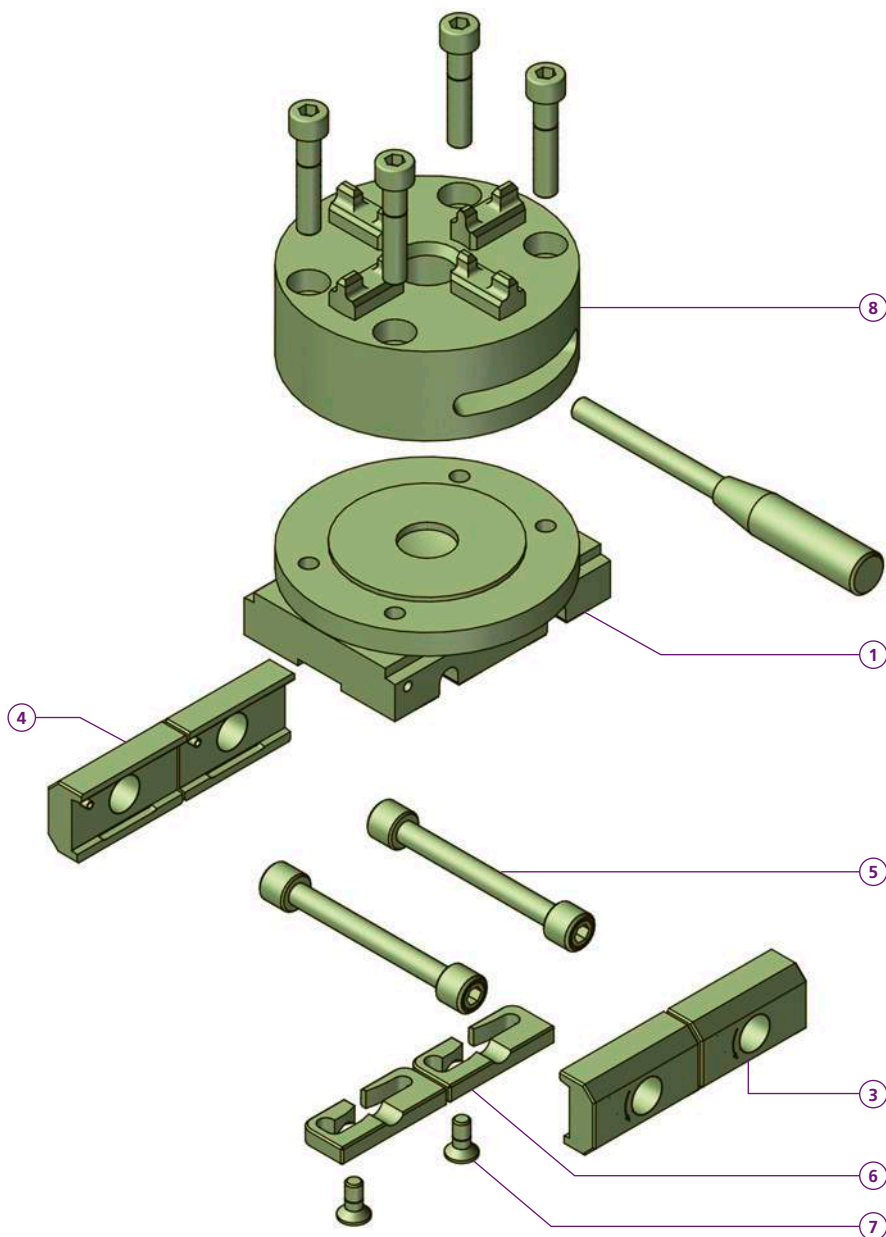
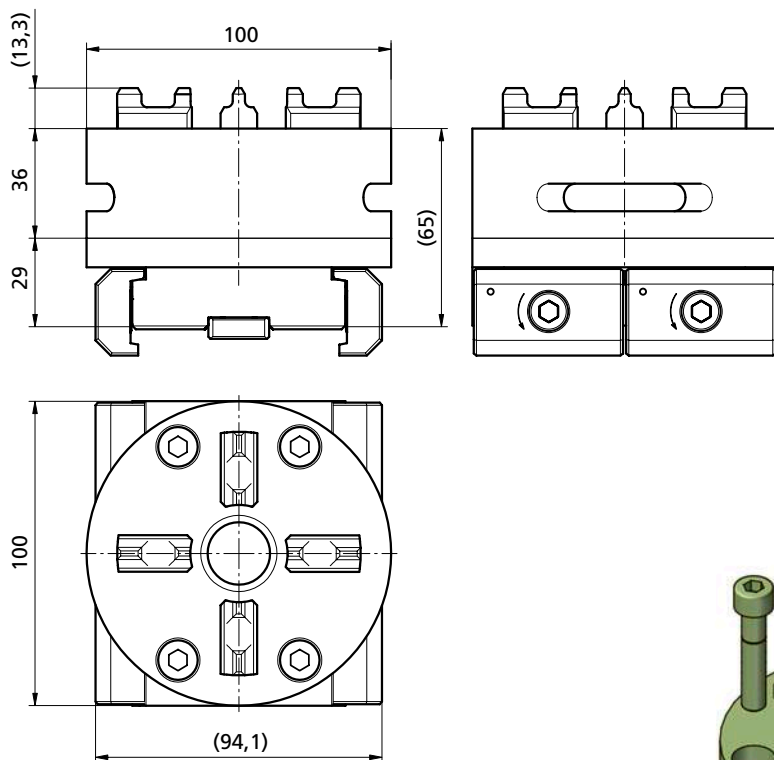

PS1X100-65ER-036345

- 1 1x PTX100-29
 - 3 2x PCSP50L
 - 4 2x PCSP50R
 - 5 2x PCS14
 - 6 2x PCGU2049F
 - 7 2x M6X14ISO10642
 - 8 1x ER-036345
- kg ~4,0

Bestellbeispiel / Ordering example: PS1X100-65ER-036345

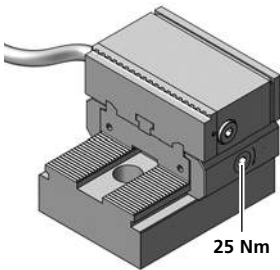
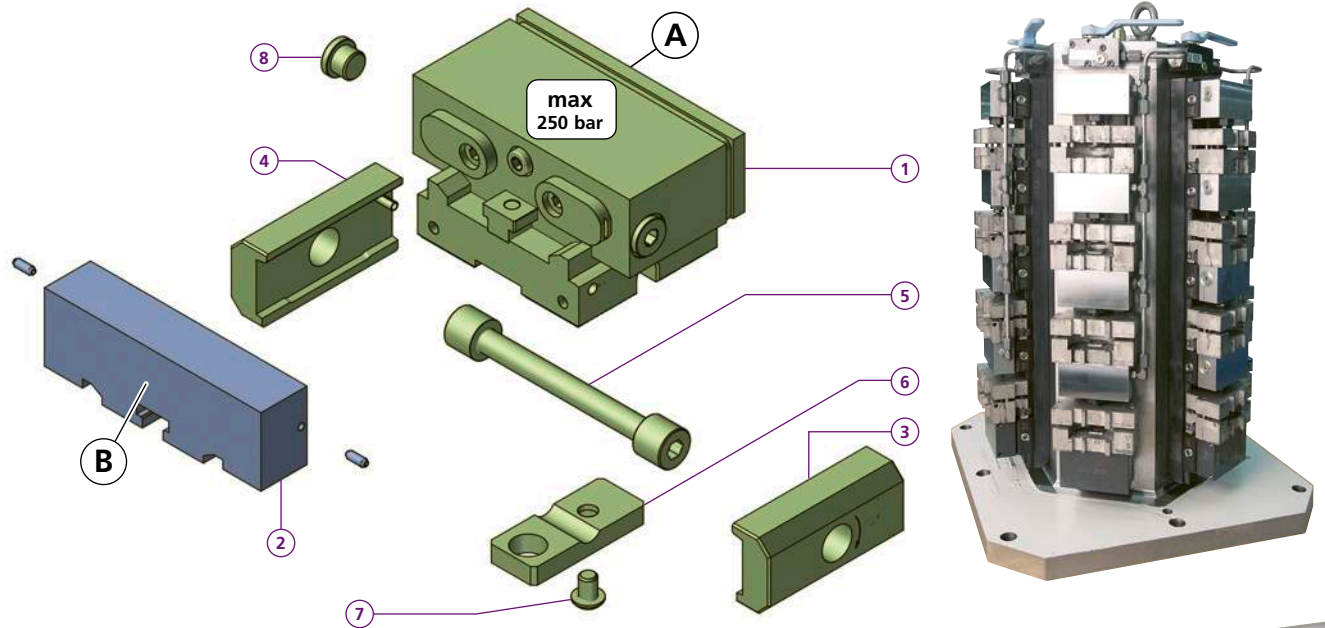
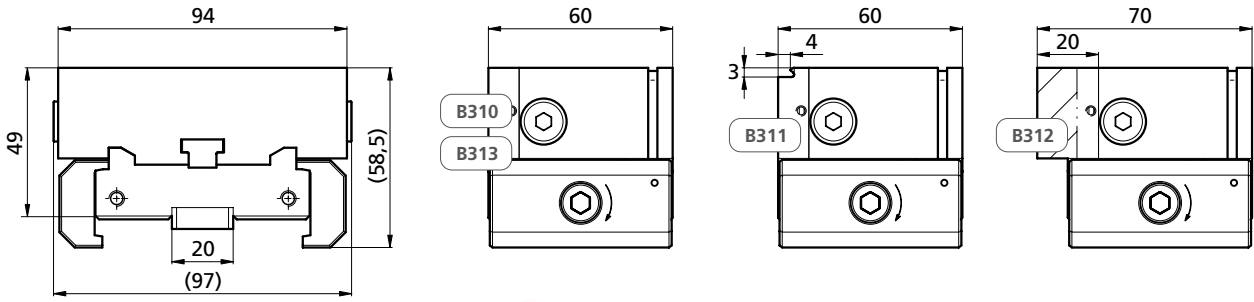

Ölvolumen / Oil volume			
Spannen / Clamping			
8 cm ³			
5 mm Hub / Stroke			
bar	~daN	~(lb)	~t
100	= 960	2116	0,96
150	= 1'440	3175	1,44
200	= 1'920	4233	1,92
250	= 2'400	5291	2,4

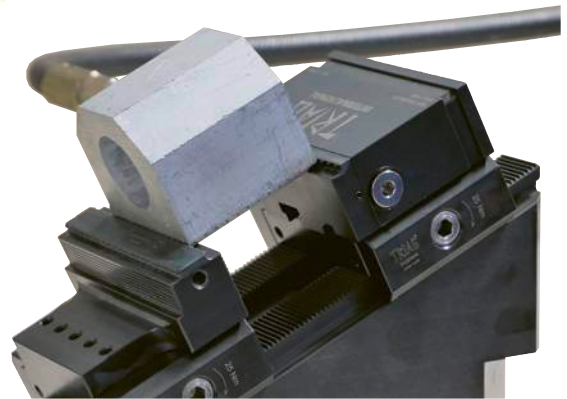

Bestellbeispiel / Ordering example: PSH1X94L49-310 & 1 x B310

	B310	B311	B312	B313
C	94	94	94	94
H	31,5	31,5	31,5	31,5
L	10	10	20	10
i	HV700 x0,2mm	57HRC	*	HV700 x0,2mm
kg	~0,18	~0,17	~0,39	~0,17

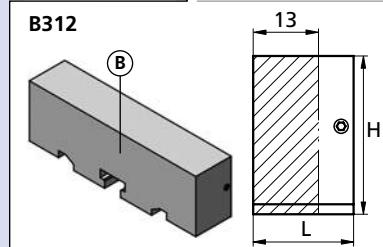
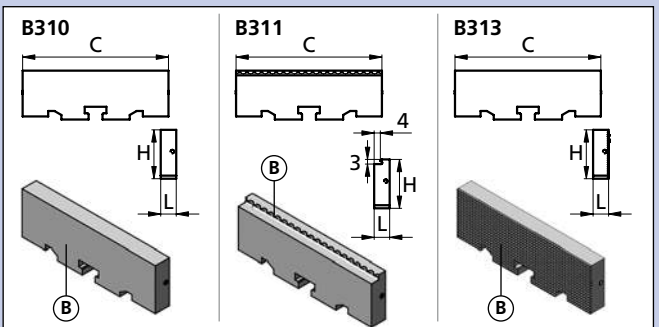

Zum Erstellen Ihrer individuellen Formbacke:

Schnittzeichnung zum Ermitteln der maximalen Bearbeitungsprofiltiefe

If a dedicated jaw is being machined:
Sectional drawing to determine the maximum machining depth

PSH1X94L49-310

- 1 1x ZF191349
 - 2 1x _____
 - 3 1x PCSP60R
 - 4 1x PCSP60L
 - 5 1x PCS14
 - 6 1x PCGU2049
 - 7 1x M6X815O7380
 - 8 2x TN100014
- kg ~1,94

* = weich / soft (1.7225 Vergütungsstahl / Tempering steel)

für Hartmetalldruckstücke
 for carbide grippers

Art. Nr.	kg	Y	X
PC4349	~0,21	43	49
PC4834	~0,17	48	34
PC12549	~0,46	125	49

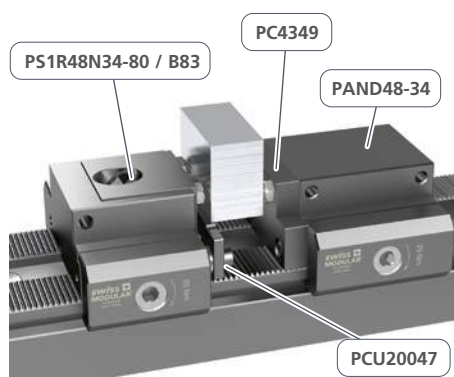
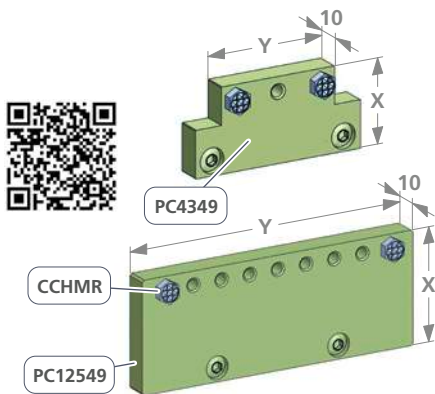

für Hartmetalldruckstücke und Fräsanschlag
 for carbide grippers and milling buffer

Art. Nr.	kg	X
PC4834RF	~0,34	34
PC4849RF	~0,44	49
PC9434RF	~0,43	34
PC9449RF	~0,63	49

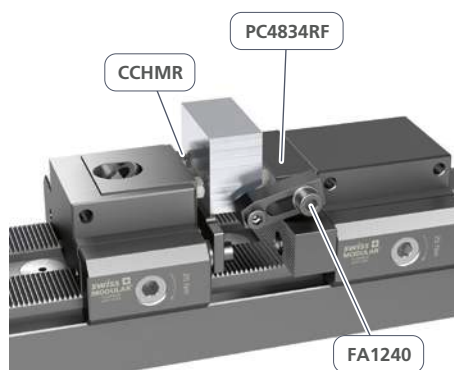
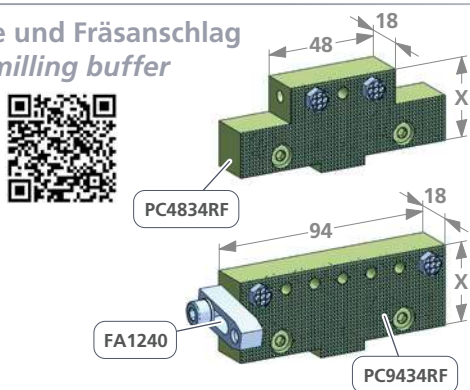

mit pendelnden Kugeldruckstücken
 with swinging ball thrust grippers

Art. Nr.	kg
PC9460	~0,45
PC9460R	~0,45

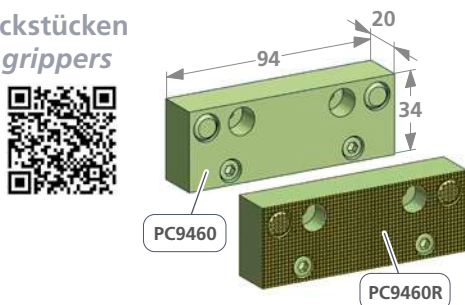

mit Prägeeinsätzen
 with embossed inserts

Art. Nr.	kg
PC9434-25PRGM8	~0,64

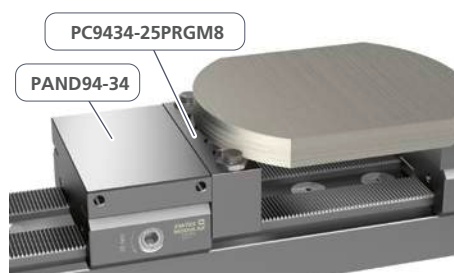
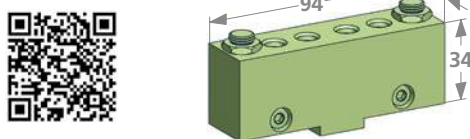

mit direkt-Prägezähnen und Spannstufen
 with direct stamping teeth and clamping steps

Art. Nr.	kg	H
PC48-34PRG	~0,18	34
PC48-49PRG	~0,24	49
PC94-34PRG	~0,25	34
PC94-49PRG	~0,48	49
PC4834-15	~0,19	34
PC4849-15	~0,24	49

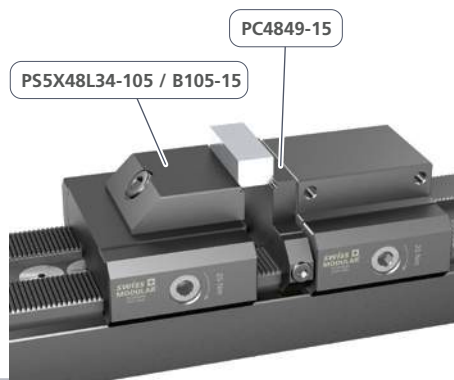
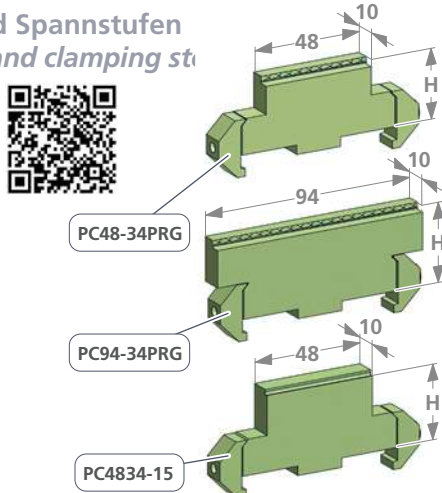

mit Druckstiften
with pressure pins

Art. Nr.	kg	Y	X
PC4349DS	~0,22	43	49
PC4834DS	~0,17	48	34
PC4849DS	~0,23	48	49
PC9434DS	~0,27	94	34
PC9449DS	~0,38	94	49
PC12549DS	~0,49	125	49



Druckstift
Pressure pin
DSE0402-60°

weitere Druckstücke
more gripping pens
p. 337

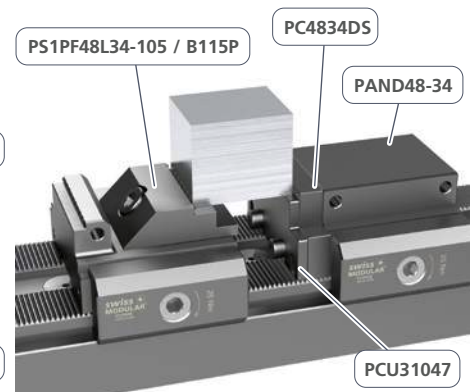
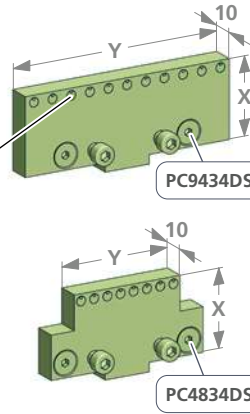

aus weichem Stahl, zur Herstellung Ihrer individuellen Backe
made of soft steel, for the production of your individual clamping jaw

Art. Nr.	kg	Z	Y	X
PC943425W weicher Stahl (1.0570)	~0,64	94	25	34
PC943430W weicher Stahl (1.0570)	~0,77	94	30	34
PC944930W weicher Stahl (1.0570)	~1,10	94	30	49
PC1254930W weicher Stahl (1.0570)	~1,46	125	30	49

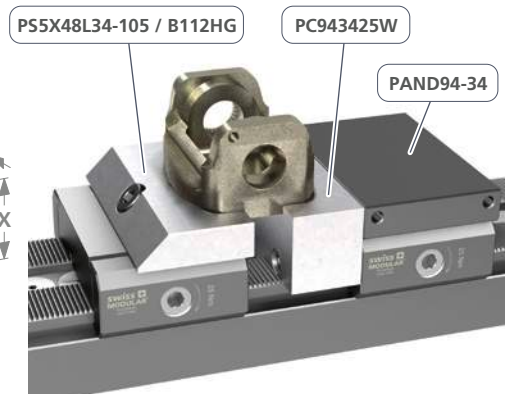
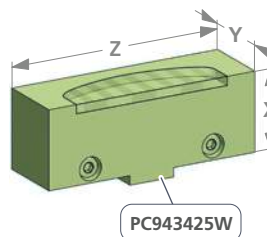

in Prismaform
in prism form

Art. Nr.	kg	Y	X
PC9434V90-2	~0,58	28	34
PC9449V90-2	~0,58	28	49
PC9434V120	~0,62	35	34
PC9449V120	~0,89	35	49

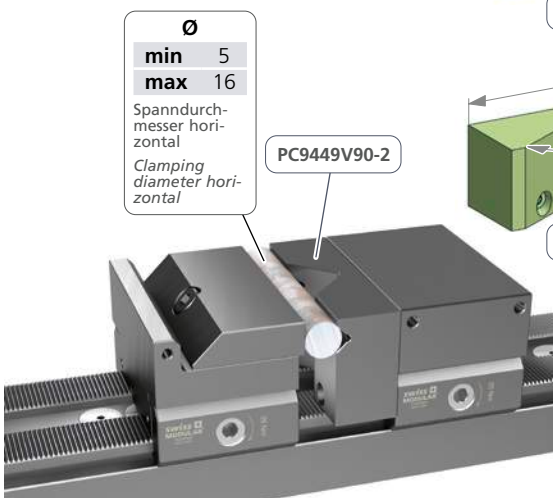
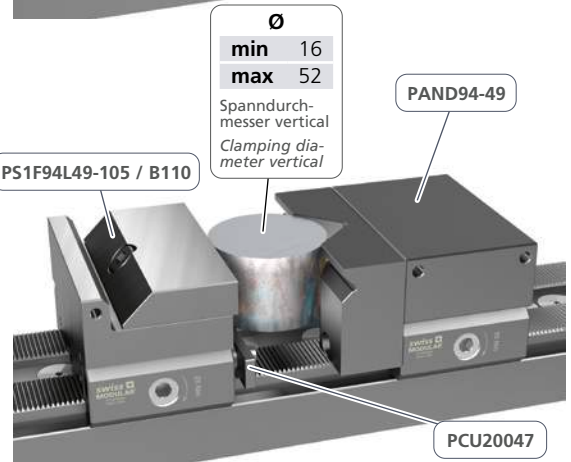
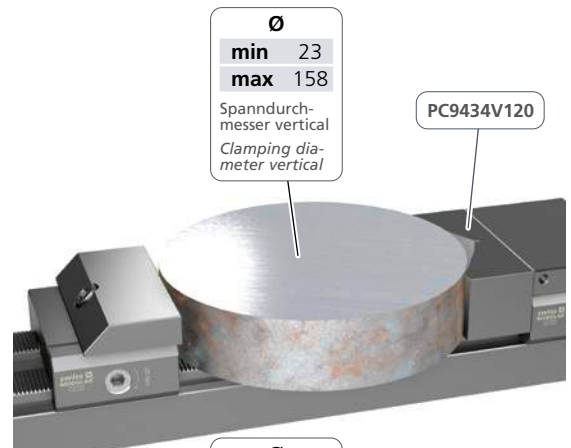
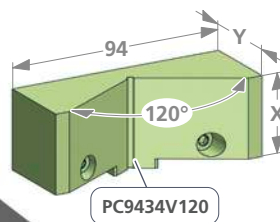
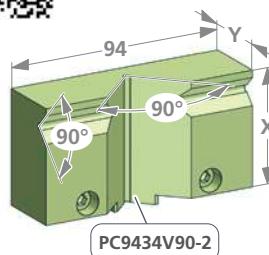

Von Niederzug zu Linear!
From pull down jaws to linear stroke!

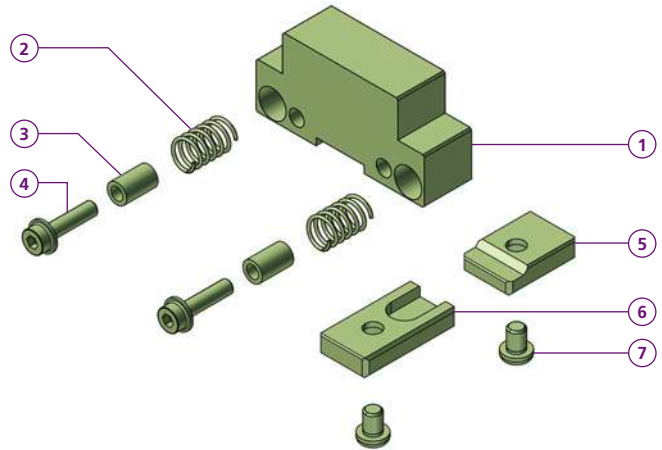
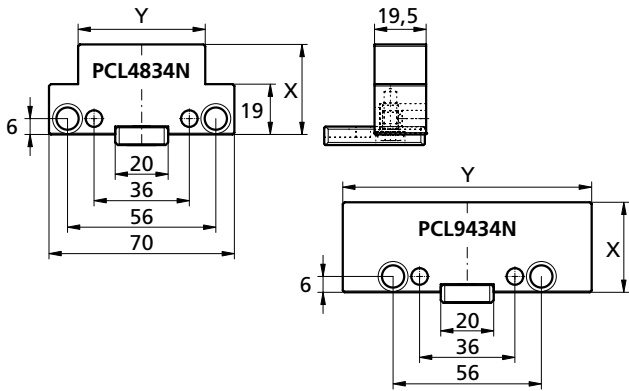

- PCL4349N**
- 1 1x TF140697
 - 2 2x FED10175
 - 3 2x PCD0813
 - 4 2x M5X20BN1392
 - 5 1x PCGU2028
 - 6 1x PCGU2030LB
 - 7 2x M6X8ISO7380
- X = 49
Y = 43
kg ~0,43

Spannhub
Clamping stroke
0/+3,8

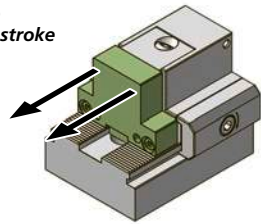

- PCL9449N**
- 1 1x TF140700
- X = 49
Y = 94
kg ~0,74

Spannhub
Clamping stroke
0/+3,8

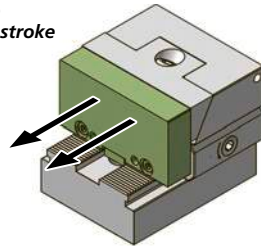

- PCL12549N**
- 1 1x T00317
- X = 49
Y = 125
kg ~0,97

Spannhub
Clamping stroke
0/+4,8

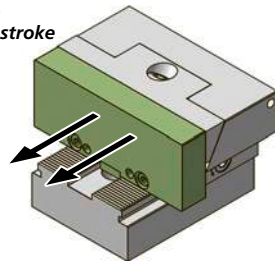

- PCL4834N**
- 1 1x TF140698
 - 2 2x FED10175
 - 3 2x PCD0813
 - 4 2x M5X20BN1392
 - 5 1x PCGU2028
 - 6 1x PCGU2030LB
 - 7 2x M6X8ISO7380
 - 8 1x M10X22ISO4762
- X = 34
Y = 48
kg ~0,35

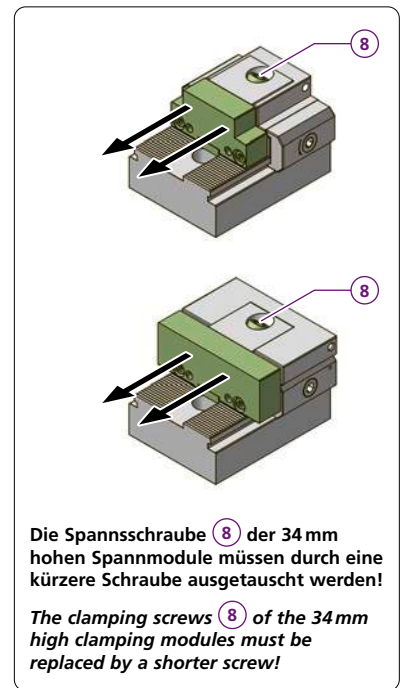

Die Spannschraube (8) der 34 mm hohen Spannmodule müssen durch eine kürzere Schraube ausgetauscht werden!
The clamping screws (8) of the 34 mm high clamping modules must be replaced by a shorter screw!

- PCL9434N**
- 1 1x TF140699
- X = 34
Y = 94
kg ~0,52

Bestellbeispiel / Ordering example: **PCL4834N**

Montagehilfe und Ersatzteile für Linearbacken
Assembling tool for linear jaws and spare parts

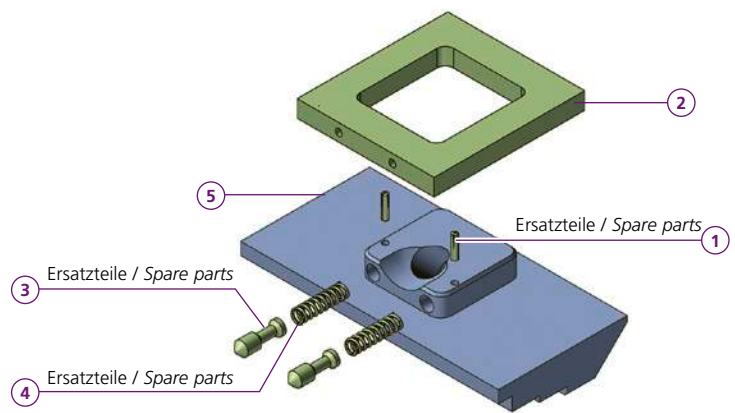
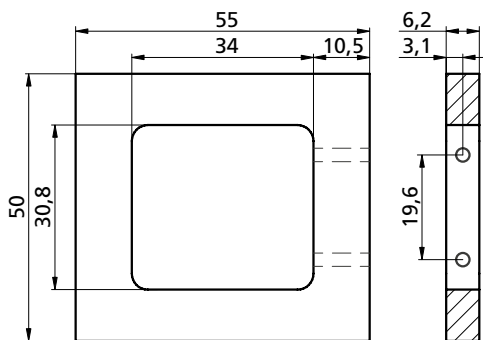

- BL-SET**
- 1 2x TN100823
 - 2 1x TK160609
 - 3 2x PCRB0516
 - 4 2x TN100614
 - 5 1x —————
- kg ~0,08

p. 84, 85

Alle Linearbacken
All linear jaws

Version mit Stiften / Version with pins
ab August / as of August 2018

Montageanleitung siehe Video
Assembly instructions see video

Version mit Kugeln / Version with balls
vor August / before August 2018



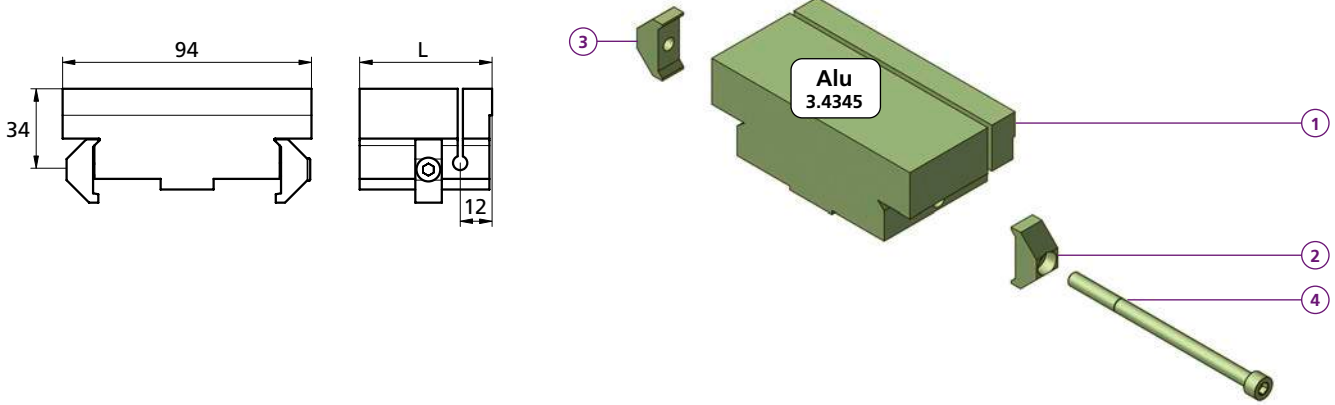

- PCFX30**
- ① 1x TF140702
 - ② 1x PCSP10B
 - ③ 1x PCSP10G
 - ④ 1x M5X85ISO4762
- L = 30
kg ~0,27
-
- PCFX35**
- ① 1x TF140703
- L = 35
kg ~0,31

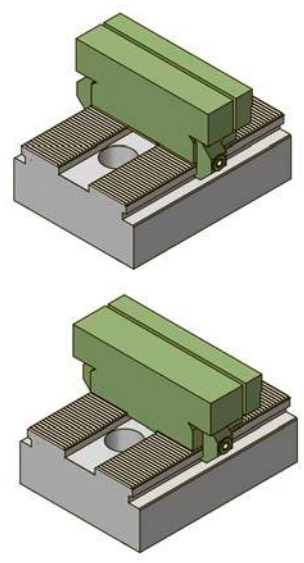

- PCFX50**
- ① 1x TF140704
 - ② 1x PCSP10B
 - ③ 1x PCSP10G
 - ④ 1x M5X85ISO4762
- L = 50
kg ~0,45
-
- PCFX70**
- ① 1x TF140705
- L = 70
kg ~0,62

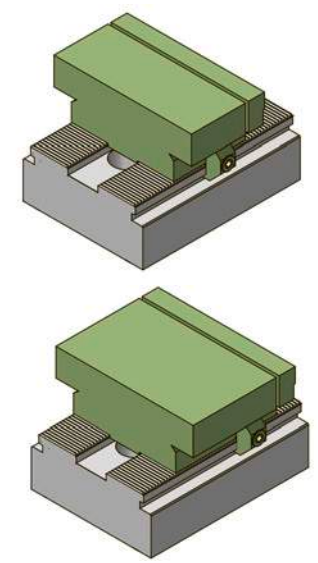

Auf Anfrage in Stahl erhältlich
On request also in steel

Bestellbeispiel / Ordering example: **PCFX30**

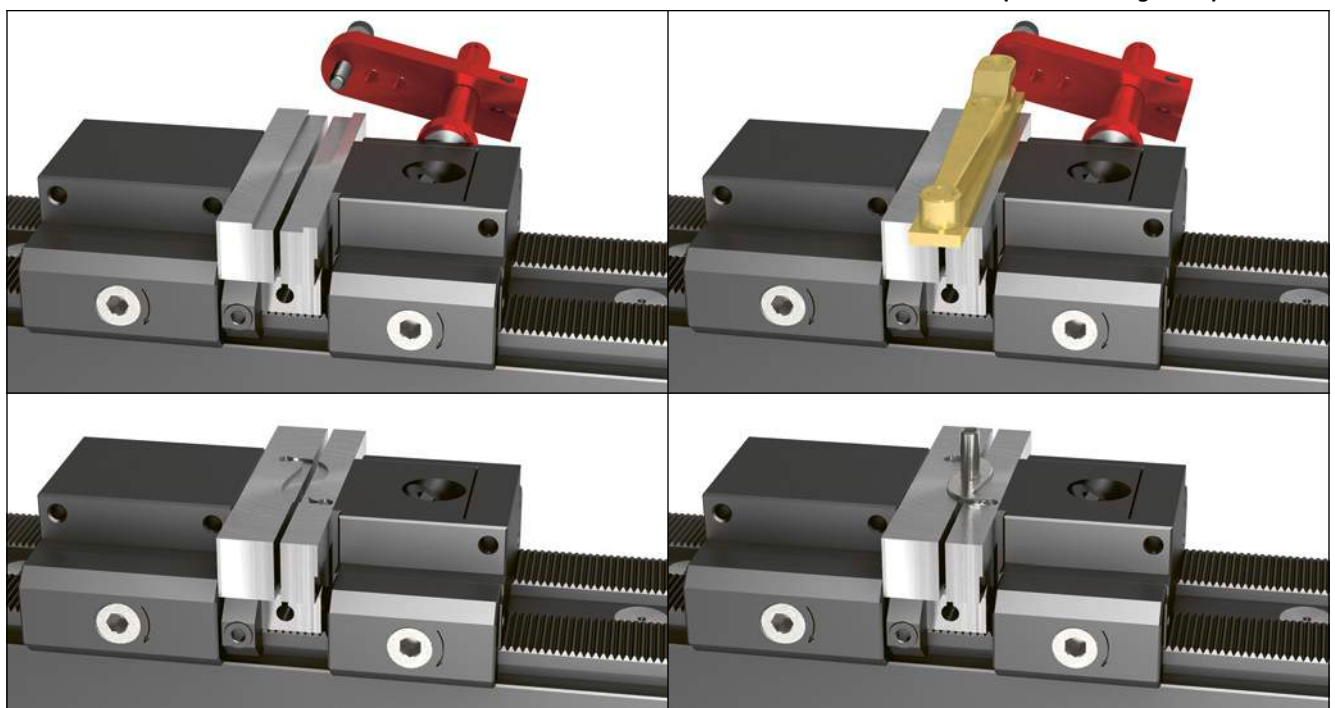

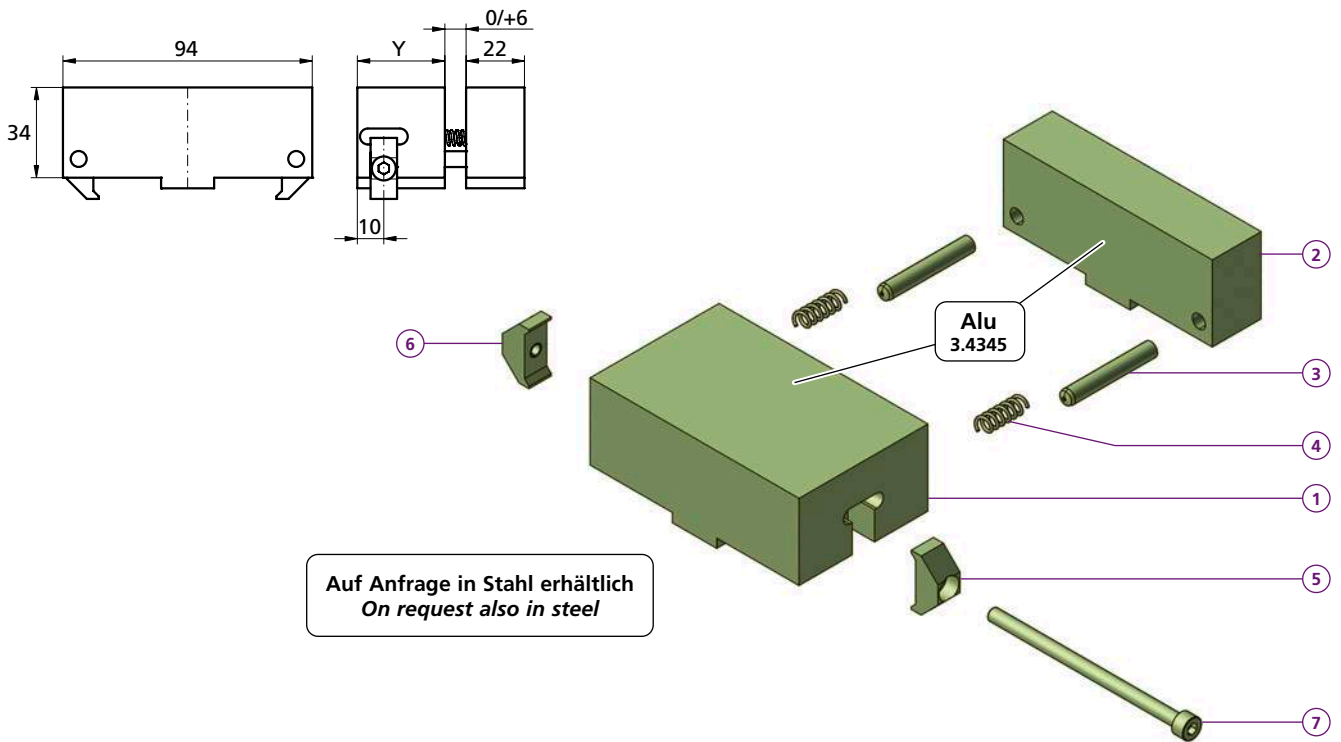

Auf Anfrage in Stahl erhältlich
On request also in steel

PCFM3322

- ① 1x PCFM33
- ② 1x PCFF22
- ③ 2x CCBO0801
- ④ 2x FED0618
- ⑤ 1x PCSP10B
- ⑥ 1x PCSP10G
- ⑦ 1x M5X85ISO4762

Y = 33
kg ~0,52

PCFM5822

- ① 1x PCFM58

Y = 58
kg ~0,75

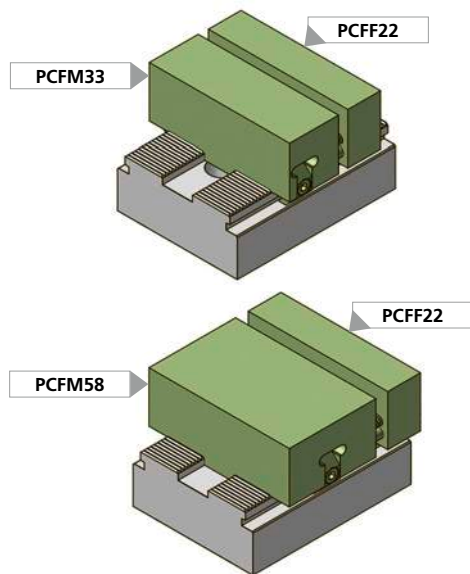

PCSP10SET kg ~0,04

- ① 1x PCSP10G
- ② 1x PCSP10B
- ③ 1x M5X85ISO4762

Bestellbeispiel / Ordering example: **PCFM3322**

Anschlagbacke flach
Jaw flat stop

	B	H	kg
PCUD34093TG	93	34	~0,11
PCUD49093TG	93	49	~0,14

Unterlagen gehärtet und geschliffen
Parallels hardened and ground

Type		B	H	kg
I	PCUD14093	93	14	~0,05
I	PCUD20093	93	20	~0,06
I	PCUD24093	93	24	~0,08
I	PCUD29093	93	29	~0,09
II	PCUD31093	93	31	~0,10
I	PCUD34093	93	34	~0,11
I	PCUD39093	93	39	~0,12
I	PCUD44093	93	44	~0,14
II	PCUD46093	93	46	~0,14
I	PCUD47093	93	37	~0,15

Niederzugbacken für die Anschlagseite
Pull-down jaws for the solid reference fase

Art. Nr.	kg	H	Z
PC9434NVB	~0,24	49,8 – 49	10,21 – 10
PC9449NVB	~0,35	34,8 – 34	10,21 – 10

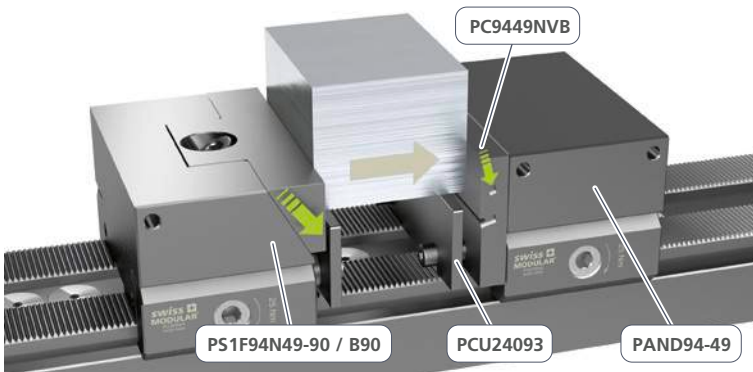
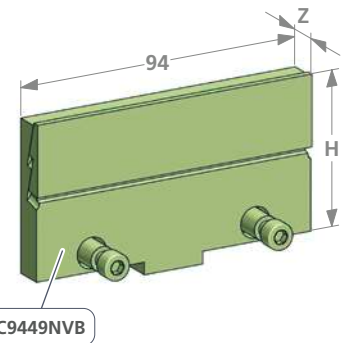

Die Niederzugbacke dient um einen zusätzlichen Niederzug-Klemmdruck auf der Anschlagseite zu erhalten.

The pull-down jaw is used to obtain an additional pull-down clamping pressure on the end module side.

Magnetische Parallelunterlagen
Magnetic steel parallels

Art. Nr.	kg	H
PCUM1409308	~0,09	14
PCUM2009308	~0,13	20
PCUM2409308	~0,15	24
PCUM2909308	~0,18	29
PCUM3109308	~0,20	31
PCUM3409308	~0,21	34
PCUM3909308	~0,24	39
PCUM4409308	~0,27	44
PCUM4609308	~0,28	46

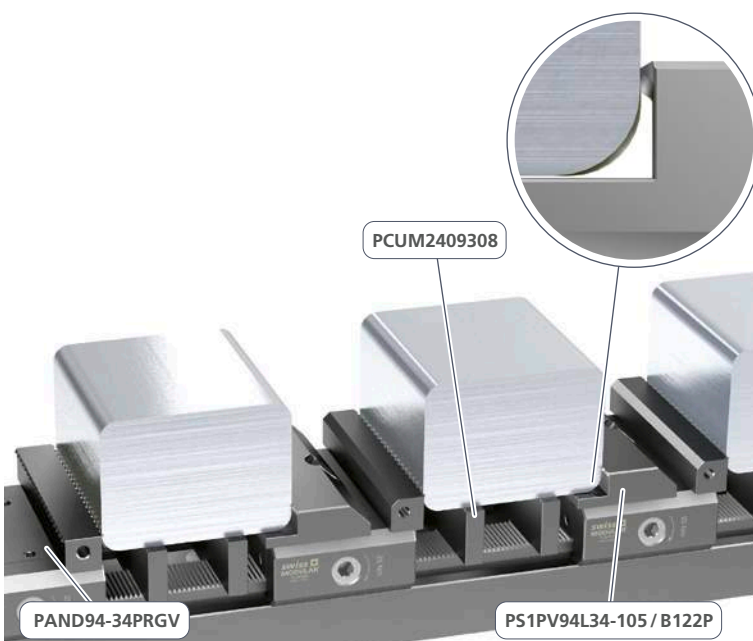
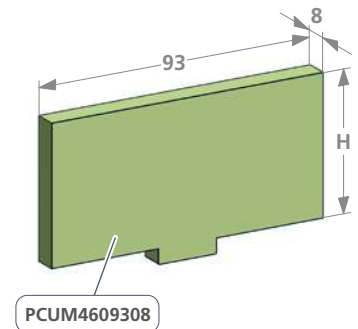

Mit diesen magnetischen Parallelunterlagen ist die Positionierung auf der Basisschiene frei wählbar. Bei Werkstücken mit grösseren Rundungen sind die Spannbacken B122P / B123P zusammen mit den Anschlagmodulen PAND94-34PRGV / PAND94-49PRGV bestens geeignet.

With these magnetic steel parallels, the positioning on the base rail is freely selectable. For workpieces with larger curves, the clamping jaws B122P / B123P together with the end modules PAND94-34PRGV / PAND94-49PRGV are best suited.



triCENTRO

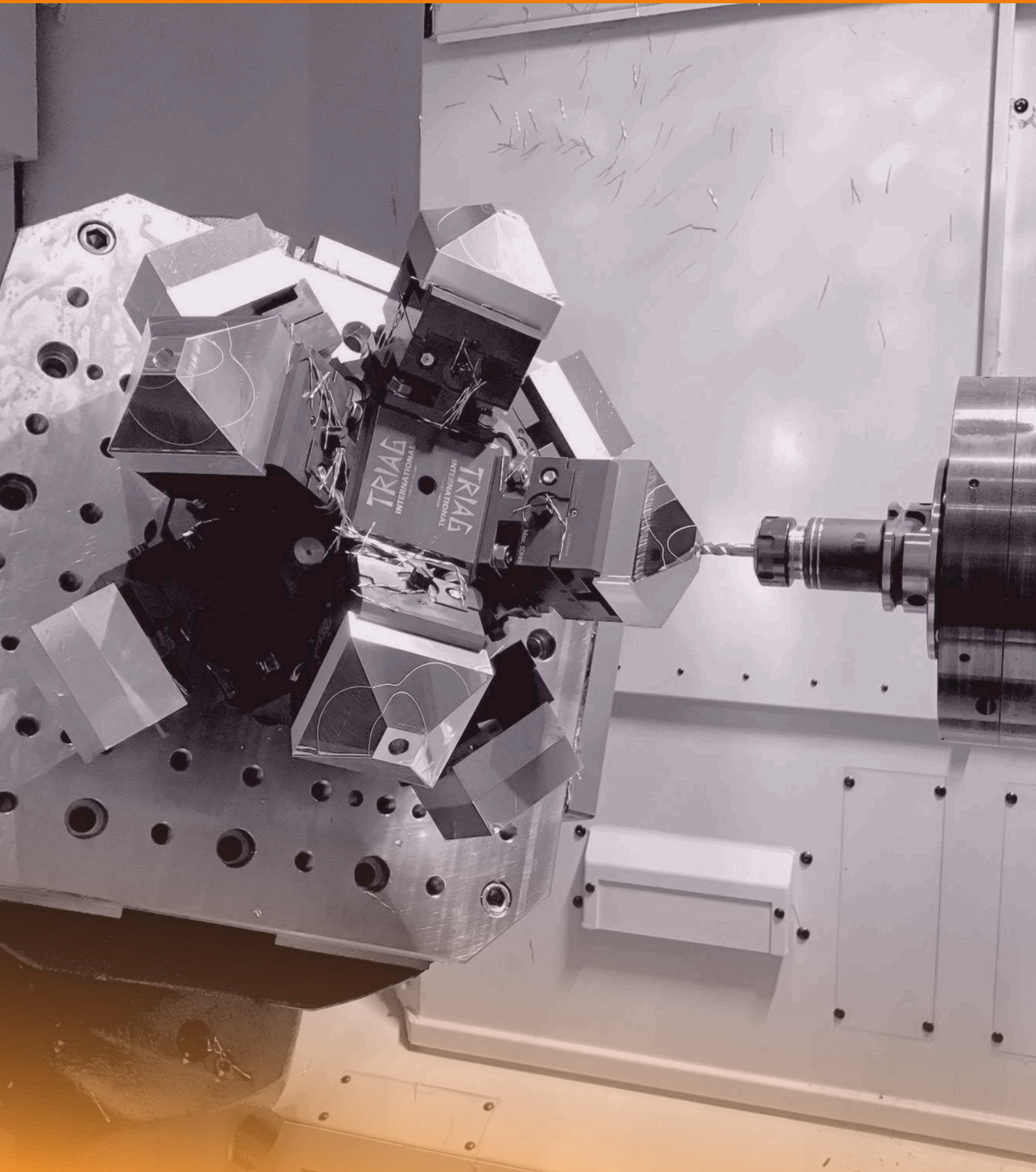



Einleitung und Anwendungsbeispiele | *Introduction and examples of application* 115

Micro - Zentrierspanner | *Micro - self centering vise* 116 - 117

5-Achs Pyramidenlösungen
5-axis pyramid solutions 35° 118

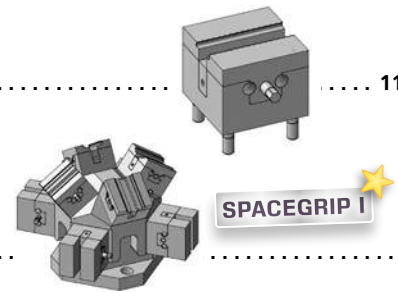

5-Achs Pyramidenlösungen
5-axis pyramid solutions 45° 119

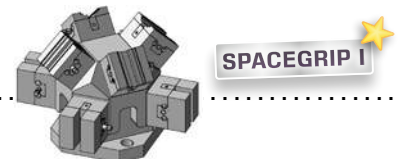

5-Achs Pyramidenlösungen
5-axis pyramid solutions 20° 122



Kompakter Zentrischspanner | *Compact self centering vise* 123 - 124

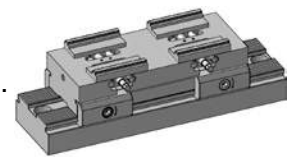

Mini Zentrierspanner | *Mini - self centering vise* 126 - 129

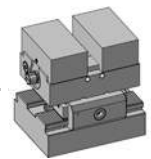

Zentrischspanner mit Anschlagbrücke
Self centering vise with center stop 130 - 131



Mini Zentrischspanner / Spannvielfalt der Backen | *Mini - self centering vise / Clamping variety of jaws* 132

5-Achs Pyramidenlösungen
5-axis pyramid solutions 45° / 90° 133

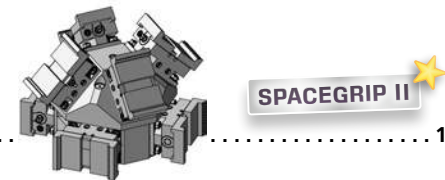

5-Achs Pyramidenlösungen
5-axis pyramid solutions 45° 136





Zentrischspanner X M Q Serien
Self centering vises X M Q series 137 - 149

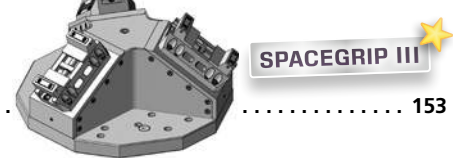

5-Achs Pyramidenlösungen
5-axis pyramid solutions 35°-3 153 - 154

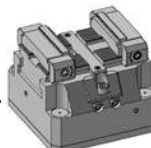

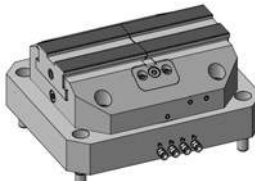
ZSP Micro - Zentrischspanner ZSP Micro - self centering vise	 156
ZSP125 Mini - Pneumatischer Zentrischspanner (einfacher Kolben) ZSP125 Mini - Pneumatic self centering vise (single piston)	 157
ZSP125 Mini - Pneumatischer Zentrischspanner (Doppelkolben) ZSP125 Mini - Pneumatic self centering vise (Double piston)	 158
ZSP Grande - Pneumatischer Zentrierspanner ZSP Grande - Pneumatic self centering vise	 160 - 161

Triag International AG bietet ein breites Sortiment an Zentrischspannern an. Neben den Zentrischspannern, die auf die Schienensysteme Power Clamp das Nullpunktsystem oppSystem passen, sind auch Ausführungen für Lochraster erhältlich.

Mit unseren modularen Zentrischspannblöcken bieten wir eine optimale Lösung für die Mehrfachspannung in Ihrer 5-Achs Fräsmaschine an. Für alle Zentrischspanner sind verschiedene Aufsatz- und Prägebacken erhältlich.

Triag International AG offers a wide range of self centering vices. In addition to the self centering vice that fit into the rail systems Power Clamp the zero point system oppSystem, mechanical self centering vice are also available.

With our modular self centric vice blocks we offer an optimal solution for multiple workholding in your 5-axis milling machine. Different jaws and stamping jaws are available for all self centering vices.

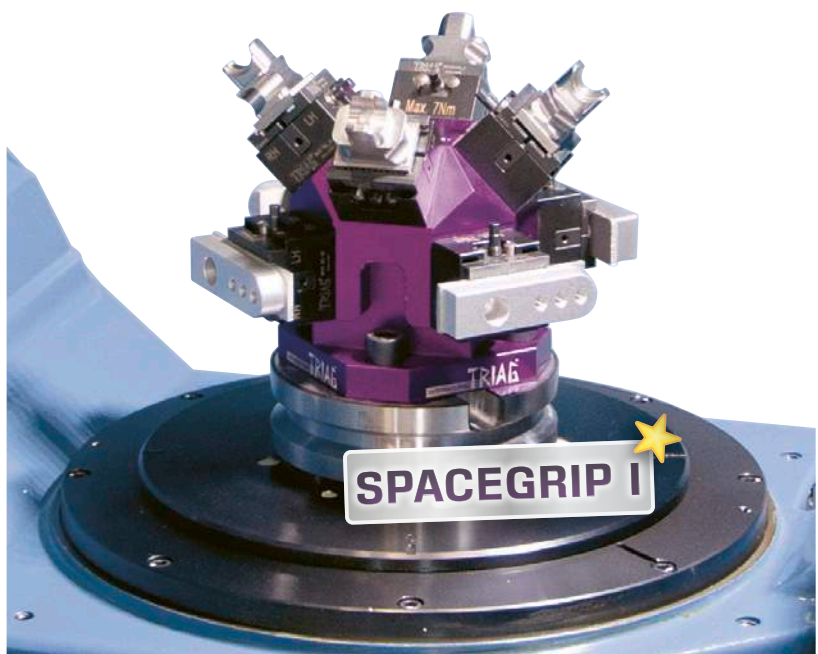
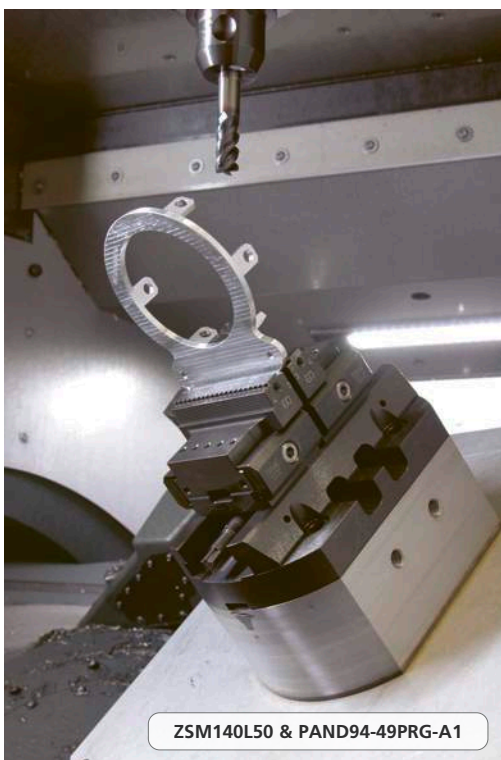

Für den Vorrichtungsbau
For dedicated fixtures

Art. Nr.			A mm	kg
MCZ40L30PRG13			3 – 13	~0,34
MCZ40L30PRG22			12 – 22	~0,33
MCZ40L30PRG31			21 – 31	~0,32
MCZ40L30W6			weicher Stahl soft steel (1.7225)	variabel ~0,33
MCZ40L30W10			weicher Stahl soft steel (1.7225)	variabel ~0,37
MCZ40L30W20			weicher Stahl soft steel (1.7225)	variabel ~0,47
MCZ40L30W30			weicher Stahl soft steel (1.7225)	variabel ~0,57

NUSS 1/4" 4.5MM

WICHTIG!
Bitte separat bestellen
IMPORTANT!
Please order separately

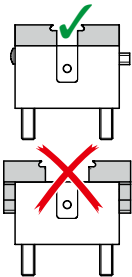

ACHTUNG / CAUTION

Die Angaben der Spannbereiche bei den verschiedenen Backen sind unbedingt zu beachten und einzuhalten! Bei unsachgemäßer Anwendung übernimmt TRIAG International keine Haftung.

The details of the clamping ranges for the different jaws must be strictly followed! In case of improper use, TRIAG International assumes no liability.

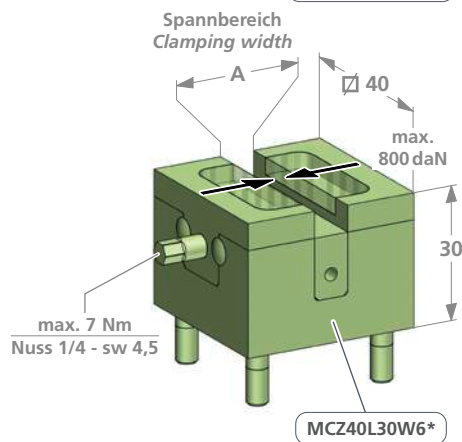
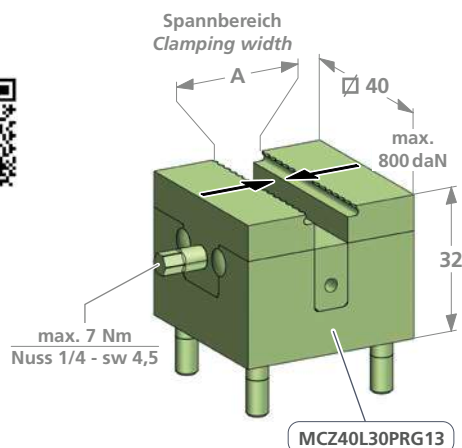

z.B. Fräsanschlag / f.e. Milling buffer

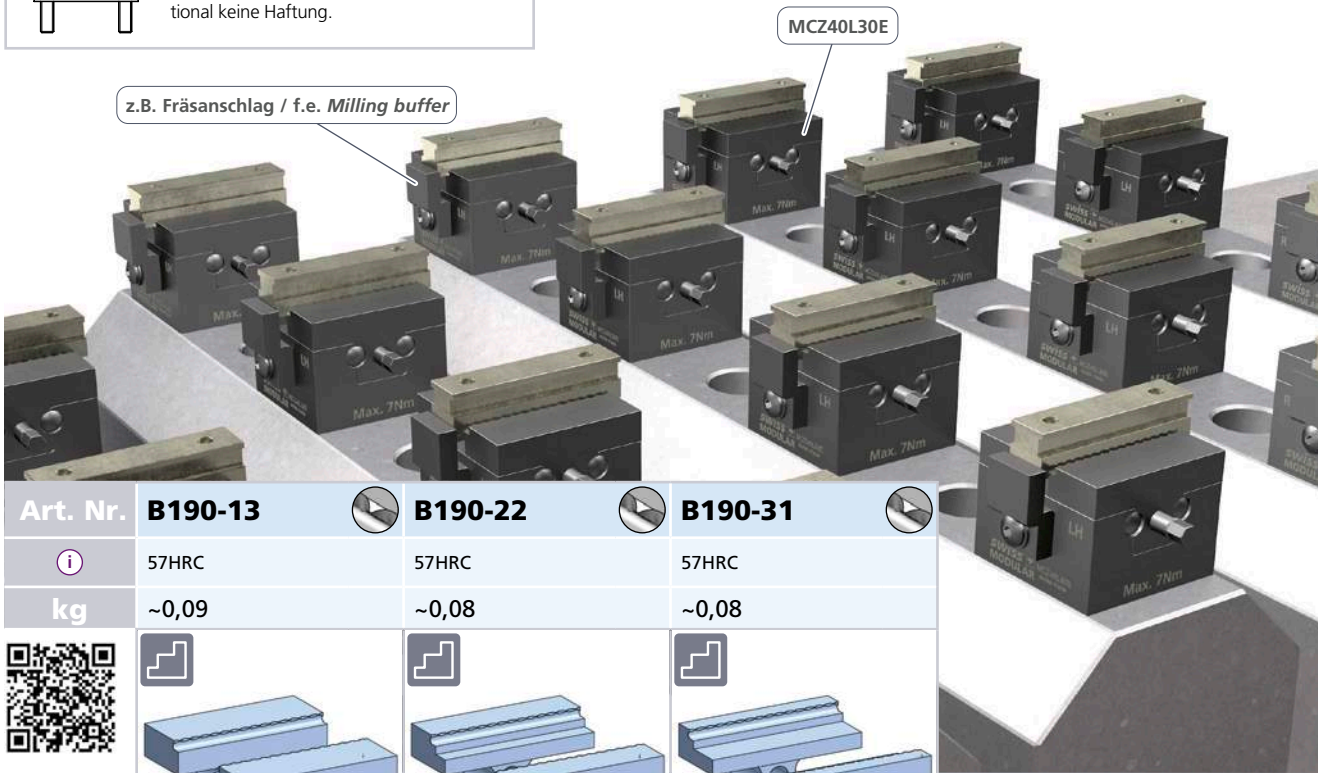

Art. Nr.	B190-13	B190-22	B190-31

Für den Vorrichtungsbau / Mit einstellbarem Mittellager
For dedicated fixtures / With adjustable center position

Art. Nr.	Backen Jaws	A mm	kg	QR
MCZ40L30E	B190-13	3 – 13	~0,24	
	B190-22	12 – 22		
	B190-31	21 – 31		
	B190W6-40	variabel		
	B190W10-40	variabel		
	B190W20-40	variabel		
	B190W30-40	variabel		

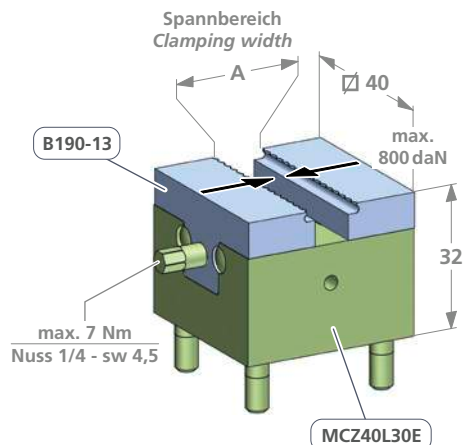

Das Zentrum kann durch das Mittellager um +/- 0,5 mm
verstellt werden. Eine schwimmende
Werkstückspannung ist auch möglich.

Lieferzustand:

Zentriert mit einer Toleranz von +/- 0,03 mm

The center can be adjusted by +/- 0,5 mm through the center
support. A floating fixture is also possible.

Delivery condition:

Centered with a tolerance of +/- 0,03 mm

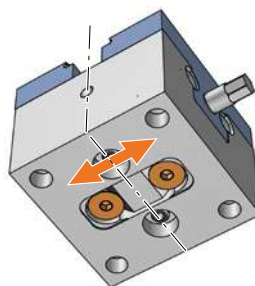

**Bedienungsanleitung
Operating instruction**



Ohne einstellbares Mittellager
Without adjustable center position

Art. Nr.	Backen Jaws	A mm	kg	QR
MCZ40L30	B190-13	3 – 13	~0,24	
	B190-22	12 – 22		
	B190-31	21 – 31		
	B190W6-40	variabel		
	B190W10-40	variabel		
	B190W20-40	variabel		
	B190W30-40	variabel		

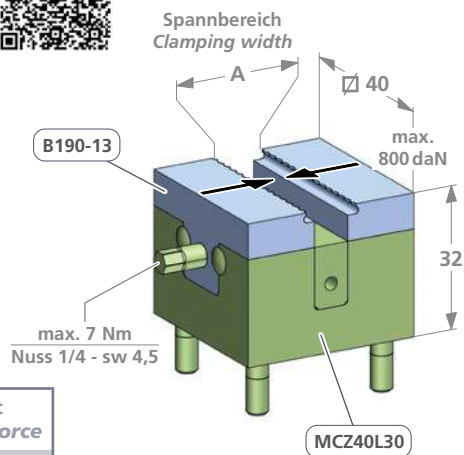

Drehmoment Torque		Spannkraft Workholding force		
Nm	(lb-ft)	~daN	~(lb)	~t
4	3	= 457	1'007	0,46
5	3,7	= 571	1'259	0,57
6	4,4	= 686	1'512	0,69
7	5,2	= 800	1'764	0,8

B190W6-40	B190W10-40	B190W20-40	B190W30-40
weicher Stahl soft steel (1.7225)	weicher Stahl soft steel (1.7225)	weicher Stahl soft steel (1.7225)	weicher Stahl soft steel (1.7225)
~0,08	~0,012	~0,22	~0,32

Weich, zur Herstellung individueller Formbacke. / Soft, for the production of individual moulding jaw.



**SEPARAT BESTELLEN
ORDER SEPARATELY**

spaceGRIP I

Die spaceGRIP Baureihe wurde speziell für die effizientere Nutzung von 5-Achsen Maschinen entwickelt. Dabei zeichnen sich alle drei Baureihen der spaceGRIP Serie mit unterschiedlichen Merkmalen aus.

Sehr kompakte Bauweise zur Aufnahme von 4 oder 8 Micro Zentrischspannmodulen. Für die Rohteilebearbeitung gibt es drei Bausätze Prägebacken (3–13 mm, 12–22 mm und 21–31 mm).

Für die zweite Spannung gibt es vier Sätze unterschiedlicher Backenrohlinge für die Einarbeitung einer Kontur. Die Spannkraft liegt bei 7 Nm 0,8t 800 daN.

spaceGRIP I

The spaceGRIP series was specially developed to improve the out puts of 5-axis machines. All three types of the spaceGRIP series have different features.

Very compact design to hold 4 or 8 micro self centering clamping modules. There are three assembly kits of stamping jaws (3–13 mm, 12–22 mm and 21–31 mm) for raw part machining.

For the second clamping, there are four sets of different jaw blanks to integrate any shapes. The clamping force is at 7 Nm 0.8t 800 daN.

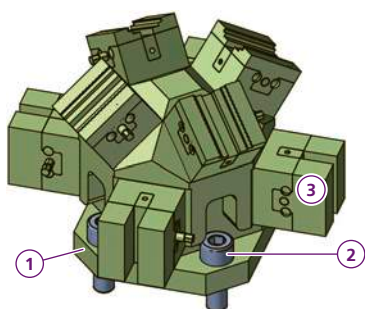
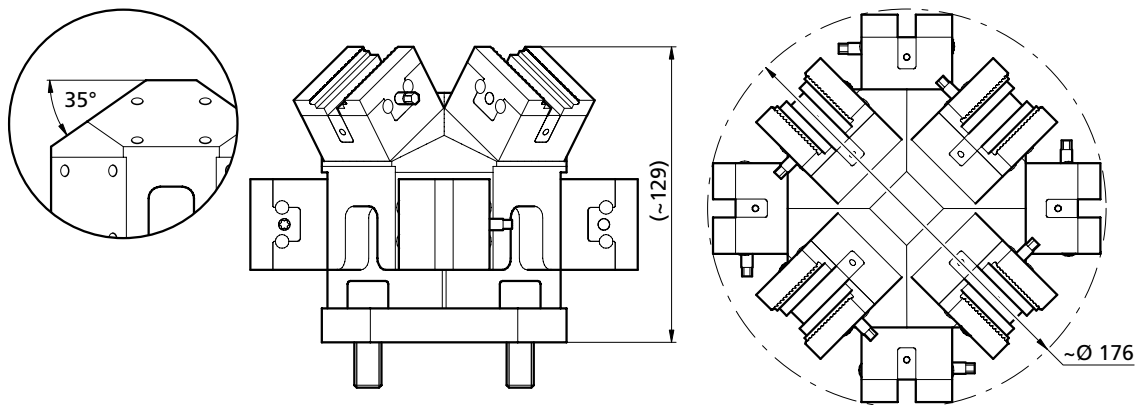

	UB5AXMCZ4035SET8
1	1x TB170676
2	4x M12X35ISO4762
3	8x Ihre Wahl / Your choice
kg	~5,1



Detailzeichnung zu dieser Schnittstelle
Detail drawing to interface

p. 116 - 117

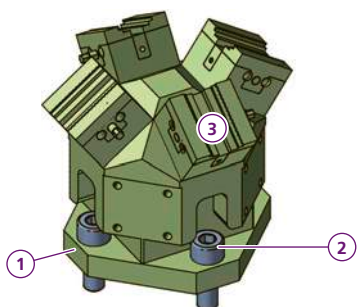

	UB5AXMCZ4035SET4
1	1x TB170676
2	4x M12X35ISO4762
3	4x Ihre Wahl / Your choice
kg	~3,2



Detailzeichnung zu dieser Schnittstelle
Detail drawing to interface

p. 116 - 117

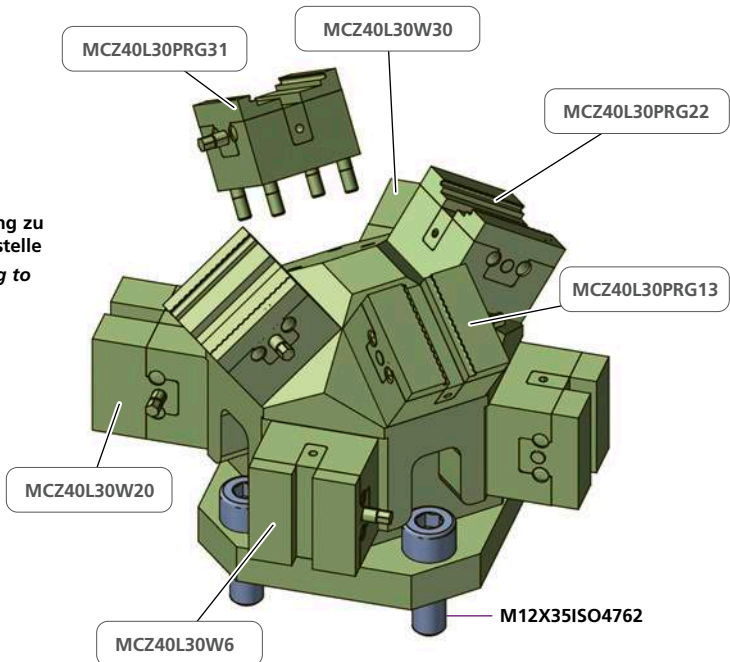

NUSS 1/4" 4.5MM

WICHTIG!
Bitte separat bestellen
IMPORTANT!
Please order separately



Bestellbeispiel / Ordering example:
2 x UB5AXMCZ40-35SET8 & 8 x MCZ40L30W10 &
8 x MCZ40L30PRG22 & 1 x Nuss 1/4 - sw 4,5

Separat bestellen / Order separately

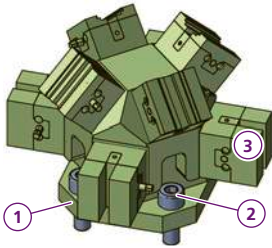

- UB5AXMCZ40-45SET8**
- 1x TK140867
 - 4x M12X35ISO4762
 - 8x Ihre Wahl/ Your choice
- kg ~5,2



Detailzeichnung zu dieser Schnittstelle
Detail drawing to interface

p. 116 - 117

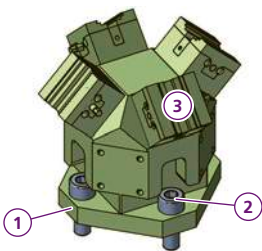
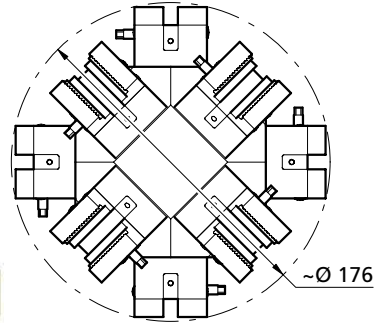
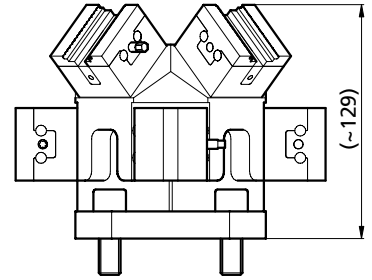
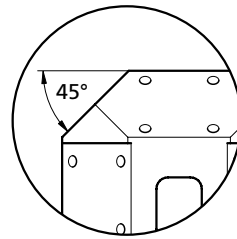

- UB5AXMCZ4045SET4**
- 1x TK140867
 - 4x M12X35ISO4762
 - 4x Ihre Wahl/ Your choice
- kg ~4,2



Detailzeichnung zu dieser Schnittstelle
Detail drawing to interface

p. 116 - 117

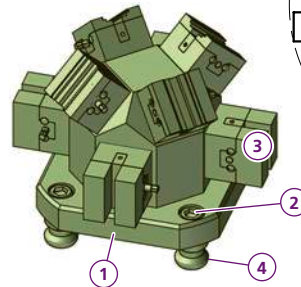

- UB5AXMCZ4045SET8-OPBM**
- 1x TK160869
 - 4x M12X20ISO4762
 - 8x Ihre Wahl/ Your choice
 - 4x OPBM18M12
- kg ~6,2



Detailzeichnung zu dieser Schnittstelle
Detail drawing to interface

p. 116 - 117

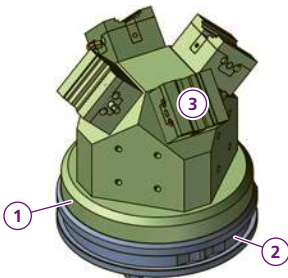

- UB5AXMCZ4045SET4-ER**
- 1x TB161062
 - 1x ER-129663 EROWA ITS-Palette
 - 4x Ihre Wahl/ Your choice
- kg ~4,1



Detailzeichnung zu dieser Schnittstelle
Detail drawing to interface

p. 116 - 117

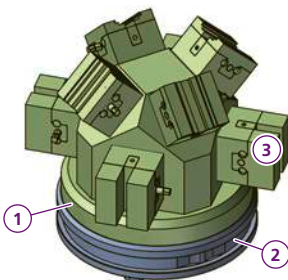

- UB5AXMCZ40-45SET8-ER**
- 1x TB161062
 - 1x ER-129663 EROWA ITS-Palette
 - 8x Ihre Wahl/ Your choice
- kg ~6,1



Detailzeichnung zu dieser Schnittstelle
Detail drawing to interface

p. 116 - 117

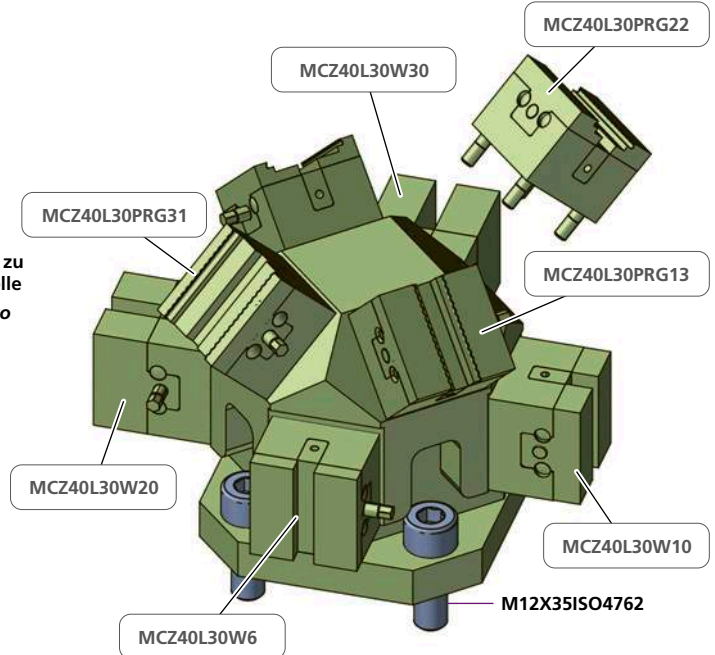

NUSS 1/4" 4.5MM

WICHTIG!
Bitte separat bestellen
IMPORTANT!
Please order separately



Bestellbeispiel / Ordering example:
2 x UB5AXMCZ40-45SET8 & 8 x MCZ40L30W20 &
8 x MCZ40L30PRG22 & 1 x Nuss 1/4 - sw 4,5

Separat bestellen / Order separately

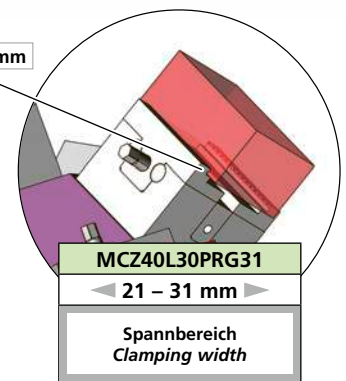
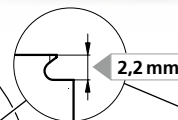
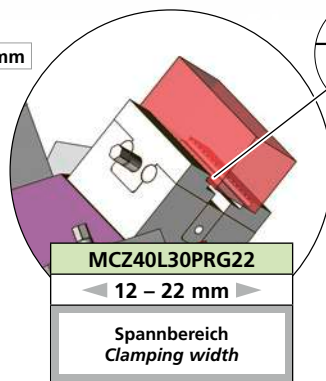
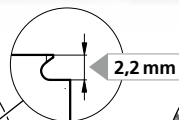
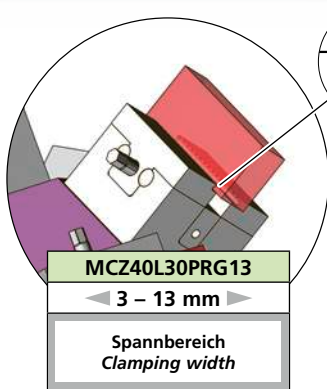

p. 116 Micro Zentrischspanner / Micro - self centering vise

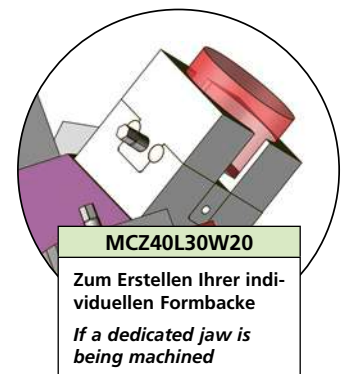

p. 116 Micro Zentrischspanner / Micro - self centering vise

Anwendungsbilder
Pictures of application to

MICRO

Zentrischspanner
self centering vise

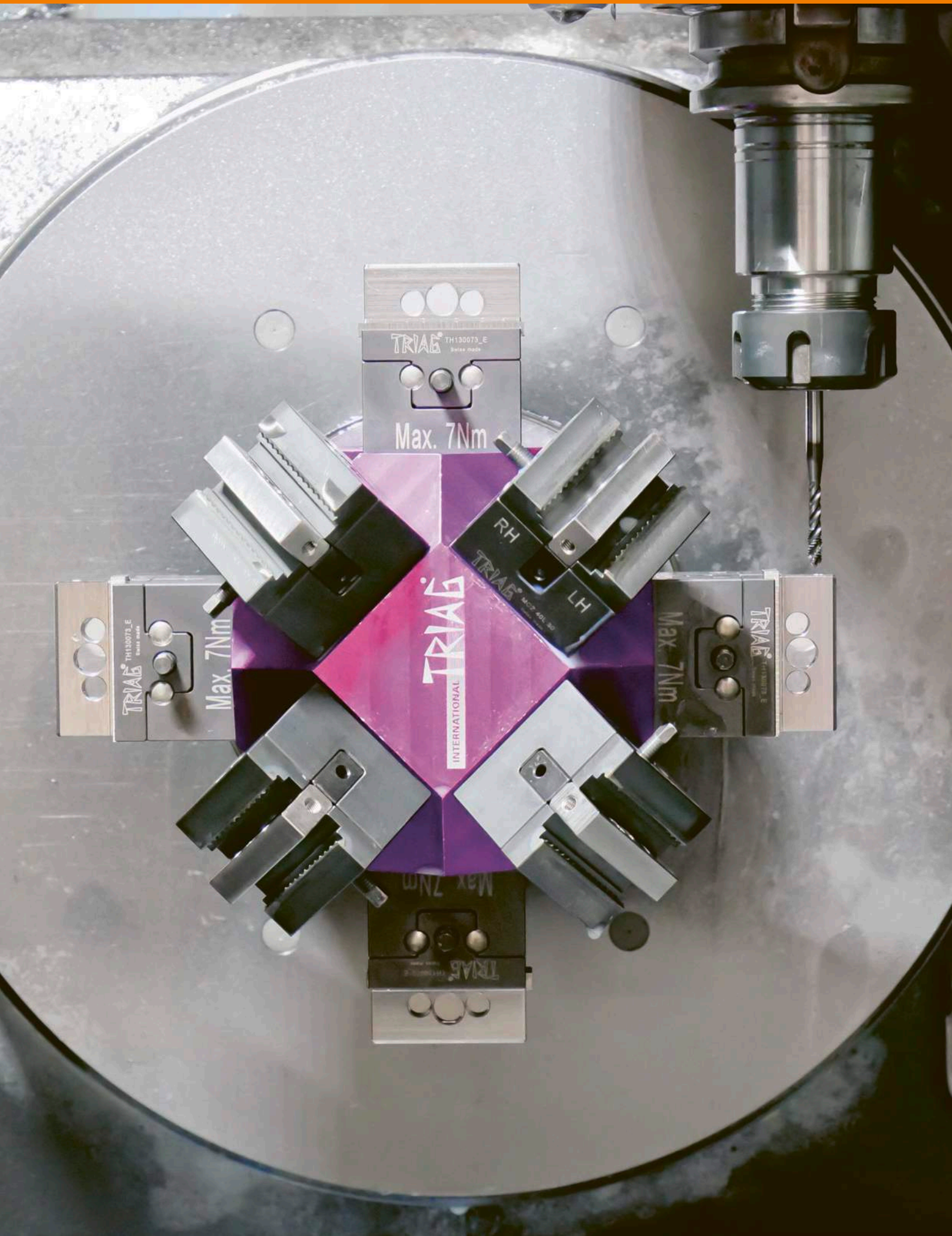

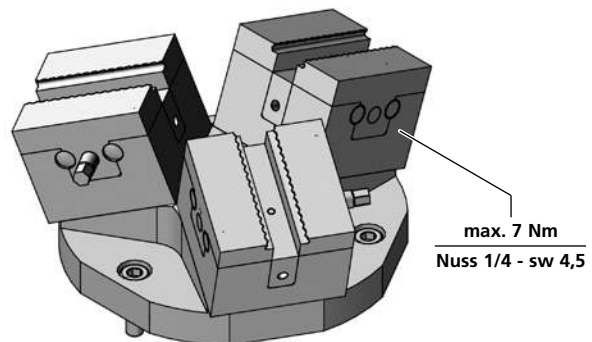
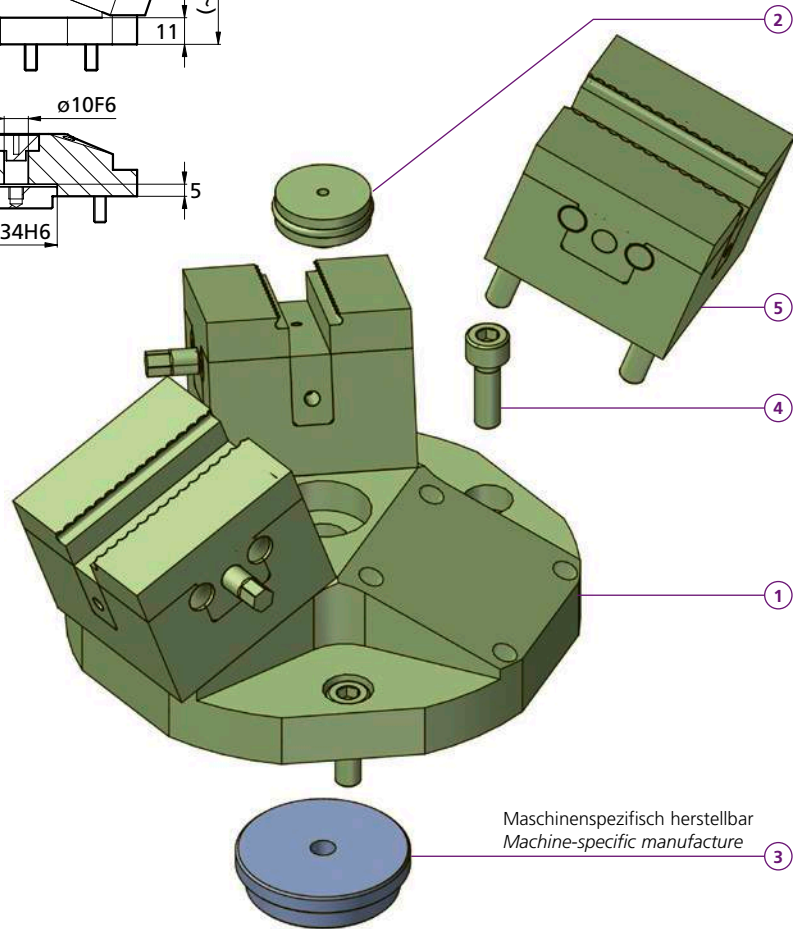
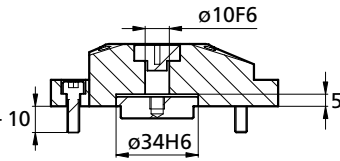
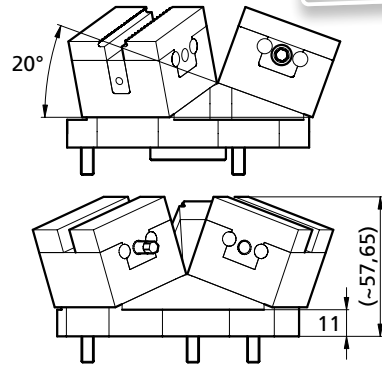
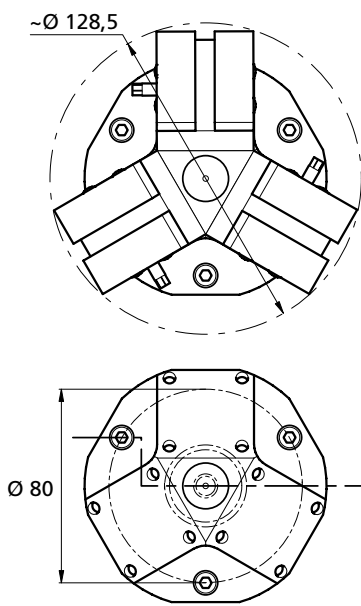

20° UB5AXSET18-3

- 1 1x TH170934
- 2 1x PCPF16L6
- 3 1x TH171176
- 4 3x M5X16ISO4762
- 5 3x Ihre Wahl / Your choice

p. 116 - 117

kg ~1,45

Drehmoment und Spannkraft siehe Seite
Torque and clamping force see page

117

NUSS 1/4" 4.5MM

WICHTIG!
Bitte separat bestellen
IMPORTANT!
Please order separately



Bestellbeispiel / Ordering example : 1 x UB5AXSET18-3 & 1x TH171176 & 3x M5x16

Kompakter Zentrischspanner Compact self centering vise

triCENTRO

Art. Nr.	Backen Jaws	A mm	B mm	kg
PCZ80L40PRG62	B210-26	32 – 62	6 – 35	~1,71
	B210W11-60	variabel	variabel	
	B210W20-60	variabel	variabel	

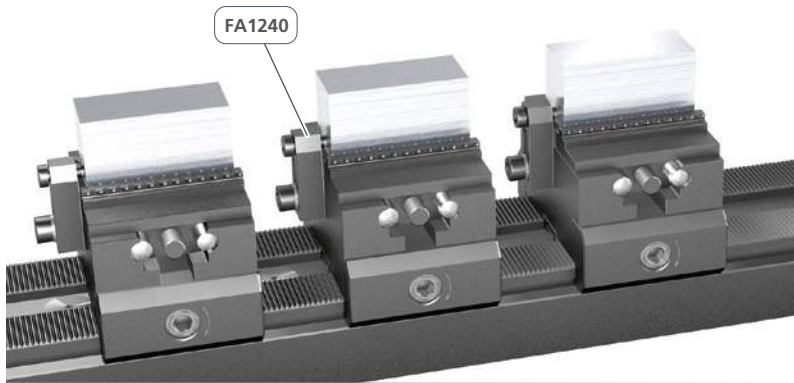
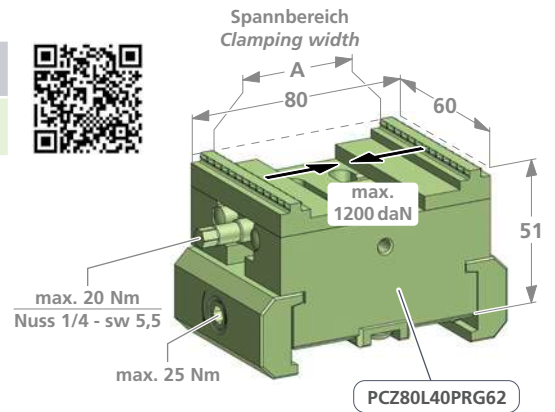

Drehmoment Torque		Spannkraft Workholding force		
Nm	(lb-ft)	~daN	~(lb)	~t
5	3,7	= 410	900	0,41
10	7,4	= 830	1'830	0,83
15	11,0	= 1'250	2'760	1,25
20	14,8	= 1'200	2'645	1,20

Für den Vorrichtungsbau
For dedicated fixtures

Art. Nr.	Backen Jaws	A mm	B mm	kg
MCZ80L32PRG62	B210-26	32 – 62	6 – 35	~1,39
	B210W11-60	variabel	variabel	
	B210W20-60	variabel	variabel	

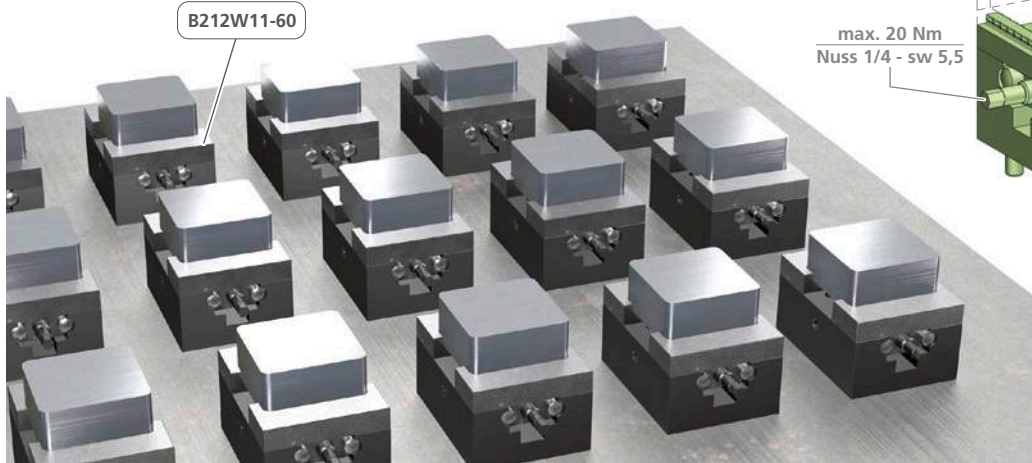
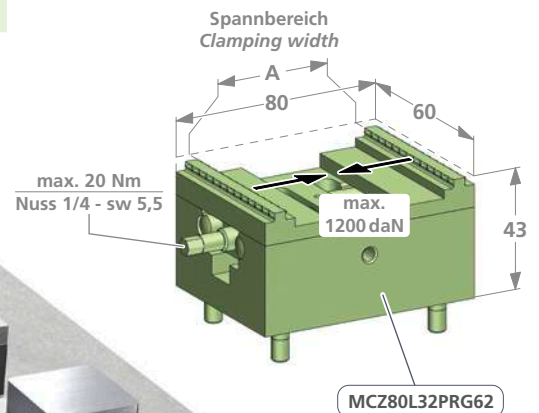

Linear- Spannbacke / Linear clamping jaw →

Art. Nr.	B210-62	B212W11-60	B212W20-60
i	57HRC	Vergütungsstahl Tempering steel (1.7225)	Vergütungsstahl Tempering steel (1.7225)
kg	~0,31	~0,31	~0,52
QR			
Image			

Weich, zur Herstellung individueller Formbacke. / Soft, for the production of individual moulding jaw.

NUSS 1/4" 5.5MM

WICHTIG!
Bitte separat bestellen
IMPORTANT!
Please order separately



**SEPARAT BESTELLEN
ORDER SEPARATELY**

Kompakter doppelter Zentrischspanner Compact double self centering vise

triCENTRO

Art. Nr.	Backen Jaws	A mm	B mm	kg
PC2Z80L40PRG62	B210-26	32 – 62	6 – 35	~4,7
	B210W11-60	variabel	variabel	
	B210W20-60	variabel	variabel	

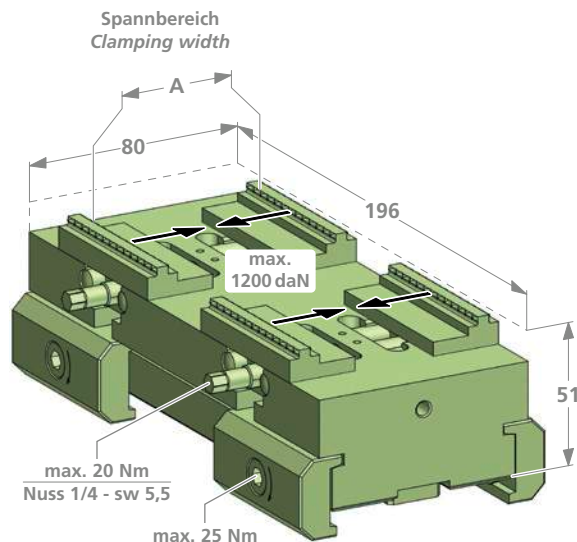

Drehmoment Torque		Spannkraft Workholding force		
Nm	(lb-ft)	~daN	~(lb)	~t
5	3,7	= 410	900	0,41
10	7,4	= 830	1'830	0,83
15	11,0	= 1'250	2'760	1,25
20	14,8	= 1'650	2'640	1,65

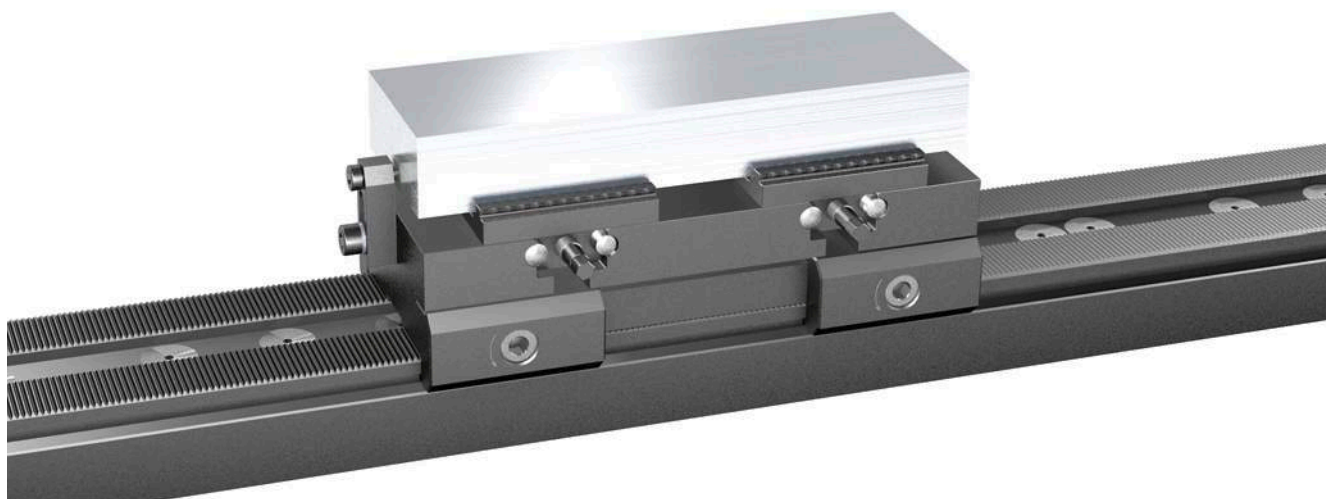

Linear- Spannbacke / Linear clamping jaw →

Art. Nr.	B210-62	B212W11-60	B212W20-60
i	57HRC	Vergütungsstahl Tempering steel (1.7225)	Vergütungsstahl Tempering steel (1.7225)
kg	~0,31	~0,31	~0,52

Weich, zur Herstellung individueller Formbacke. / Soft, for the production of individual moulding jaw.

NUSS 1/4" 5.5MM

WICHTIG!
Bitte separat bestellen
IMPORTANT!
Please order separately





Zwei Mini - Zentrischspanner mit Direktprägebacken halten verschieden lange Titanbleche. Um die verschiedenen Längen zu adaptieren, können die Spanner in 2 mm schritten seitlich versetzt werden.

Two mini - self centering vises with direct stamping jaws holding titanium sheets in different length. To adapt the different length's the vises can be moved side words in 2 mm steps.

Sondervorrichtung für Velo-Pedale mit dem schnellwechsel Nullpunkt-System OPP
Dedicated fixture for high end bicycle pedals with quick change system OPP

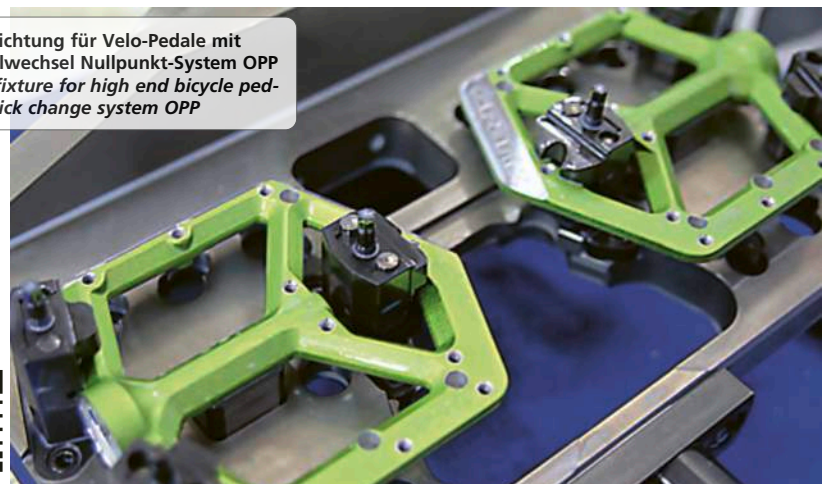

siehe Video
see video



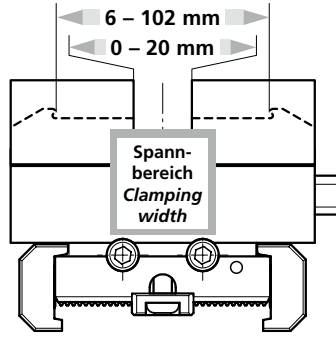
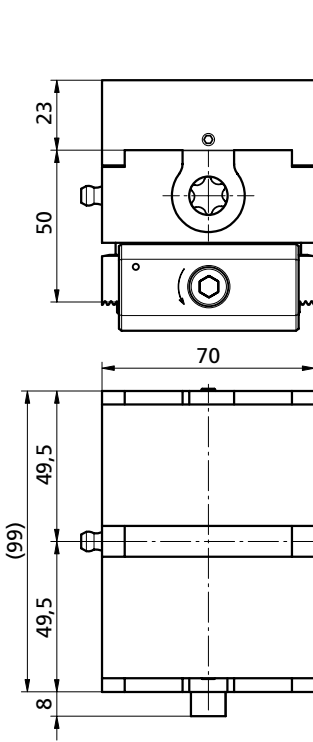

Drehmoment Torque		Spannkraft Workholding force		
Nm	(lb-ft)	~daN	~(lb)	~t
10	7,4	= 200	440	0,2
20	14,8	= 500	1'102	0,5
30	22,2	= 1'000	2'204	1,0
40	29,6	= 1'300	2'866	1,3
50	37,0	= 1'600	3'527	1,6

Innenspannung-Set / Inner clamping set

Mit diesem Set ist es möglich das Werkstück von innen zu spannen. *With this set it is possible to clamp the workpiece from the inside.*

ACHTUNG / CAUTION

Folgende Spannbacken sind dazu nicht geeignet.

The following clamping jaws are not suitable for this purpose.

B175-102, B175-121, B173-102

PCZS2439-ID-SET

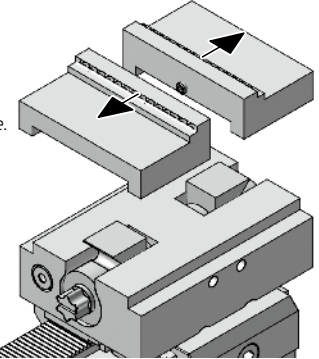

Nullpunkt des Zentrischspanners neu einstellen
How to readjust the zero point adjustment

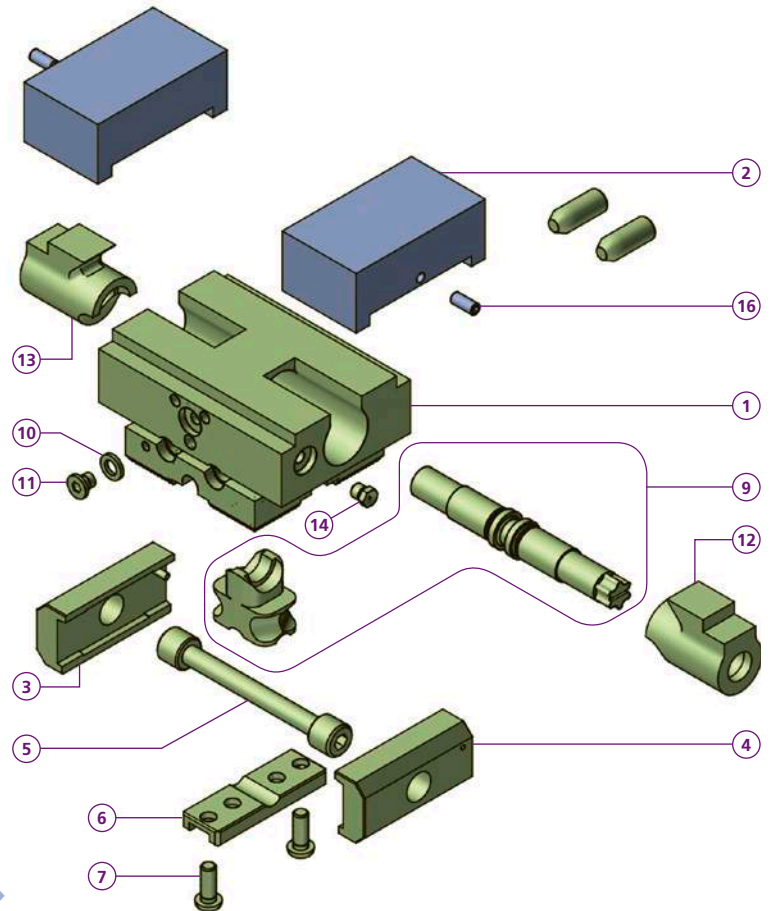
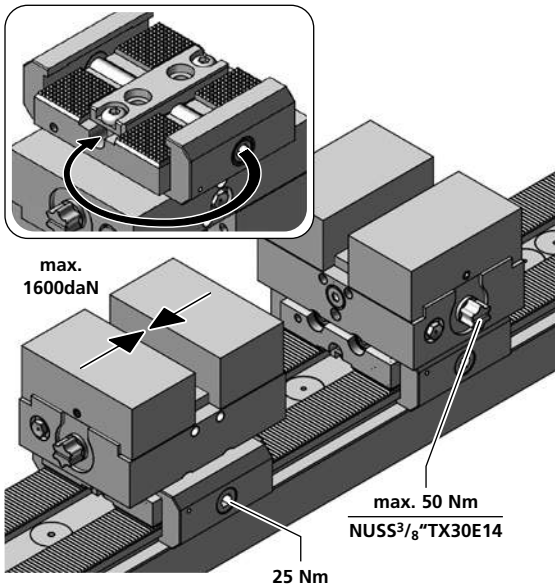

PCZ100L50	
1	1x PCZ100L50M
2	2x —
3	1x PCSP60L
4	1x PCSP60R
5	1x PCS14
6	1x PCGUW20
7	2x M6X16ISO7380
9	1x PCS14M107SET
10	1x BN726 ISO 7092 M6
11	1x BN1206 M6x6
12	1x PCZS2439L
13	1x PCZS2439R
14	1x PCZSNP
15	4x PCZJ1025
16	2x TN100140
kg	~2,5

p. 128 - 129

NUSS3/8"TX30E14

WICHTIG!
Bitte separat bestellen
IMPORTANT!
Please order separately



Bestellbeispiel / Ordering example:
3 x PCZ100L50 & 6 x B170 & 1 x NUSS3/8"TX30E14

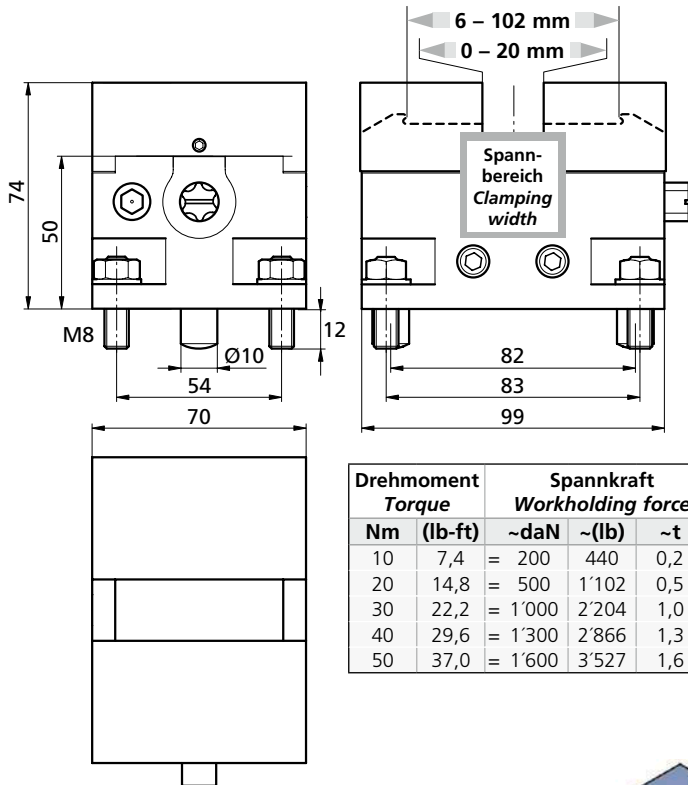

Drehmoment Torque		Spannkraft Workholding force		
Nm	(lb-ft)	~daN	~(lb)	~t
10	7,4	= 200	440	0,2
20	14,8	= 500	1'102	0,5
30	22,2	= 1'000	2'204	1,0
40	29,6	= 1'300	2'866	1,3
50	37,0	= 1'600	3'527	1,6

Innenspannung-Set / Inner clamping set

Mit diesem Set ist es möglich das Werkstück von innen zu spannen. *With this set it is possible to clamp the workpiece from the inside.*

ACHTUNG / CAUTION

Folgende Spannbacken sind dazu nicht geeignet.

The following clamping jaws are not suitable for this purpose.

B175-102, B175-121, B173-102

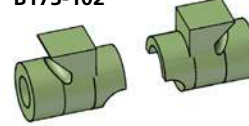

PCZS2439-ID-SET

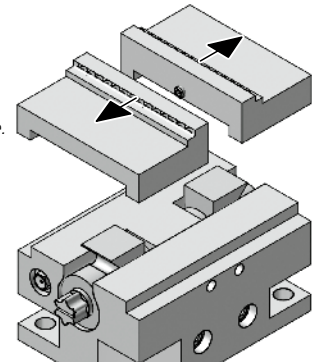

Nullpunkt des Zentrischspanners neu einstellen
How to readjust the zero point adjustment

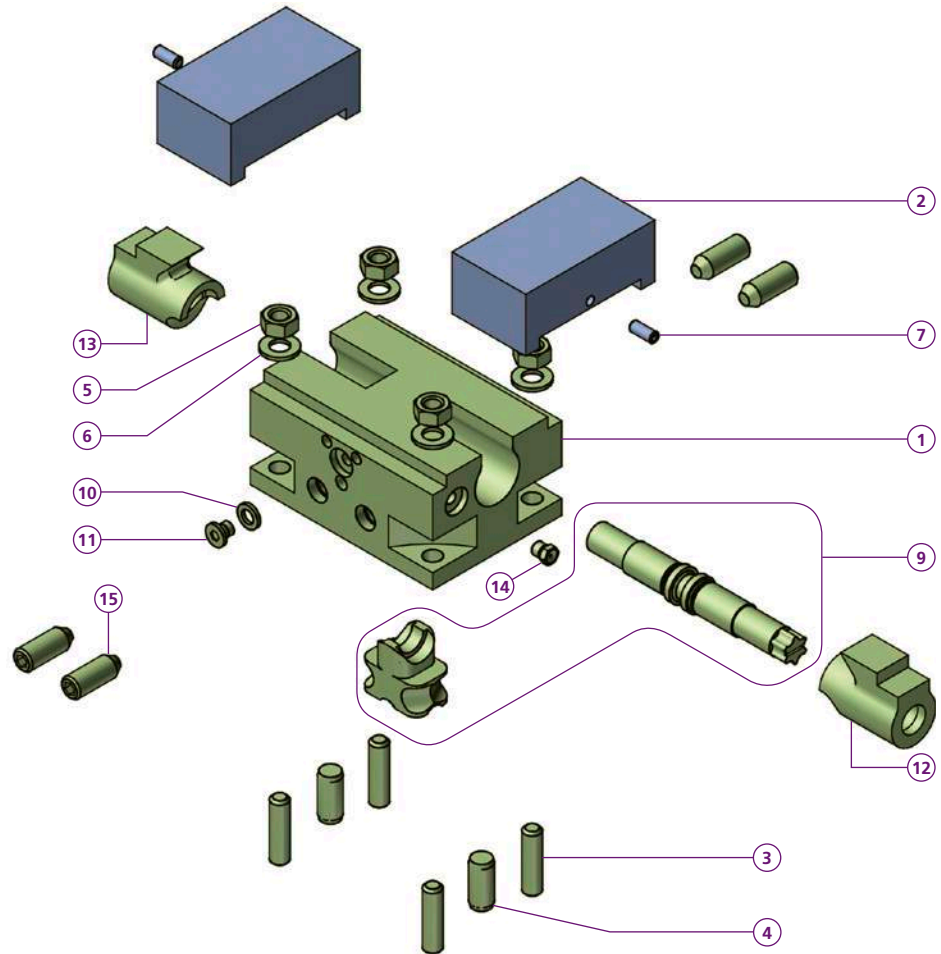
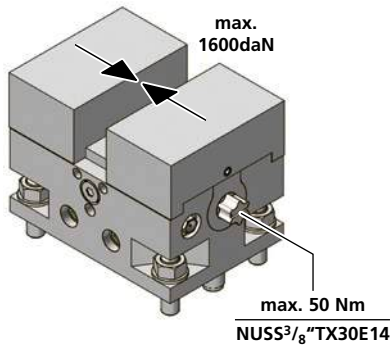

MCZ100L50	
1	1x MCZ100L50M
2	2x —
3	2x 10m6x22 ISO 8734
4	4x M8X30DIN913
5	4x M8 DIN 934
6	4x 8,4 DIN 125 A
7	2x TN100140
9	1x PCS14M107SET
10	1x BN726 ISO 7092 M6
11	1x BN1206 M6x6
12	1x PCZS2439L
13	1x PCZS2439R
14	1x PCZSNP
15	4x PCZJ1025
kg	~2,6

p. 128 - 129

NUSS3/8"TX30E14

WICHTIG!
Bitte separat bestellen
IMPORTANT!
Please order separately

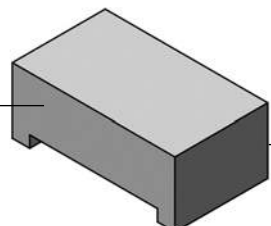
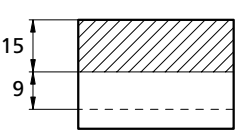
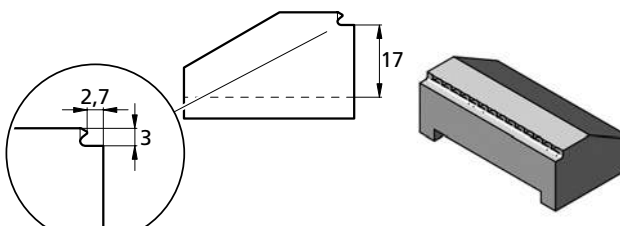
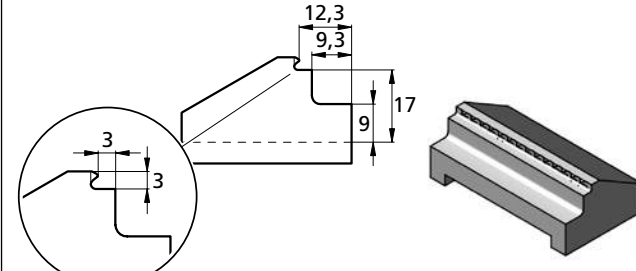
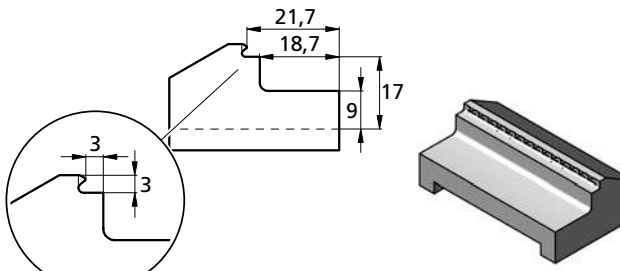
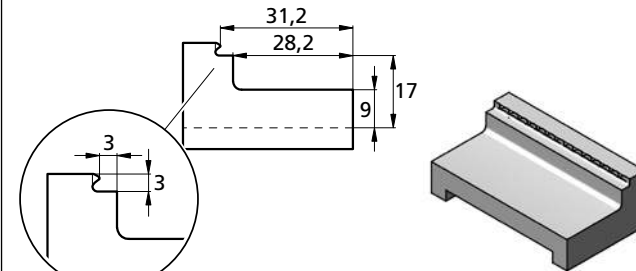
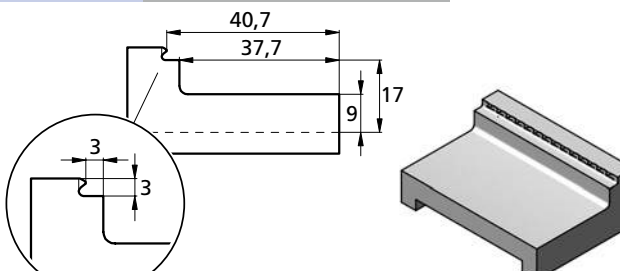
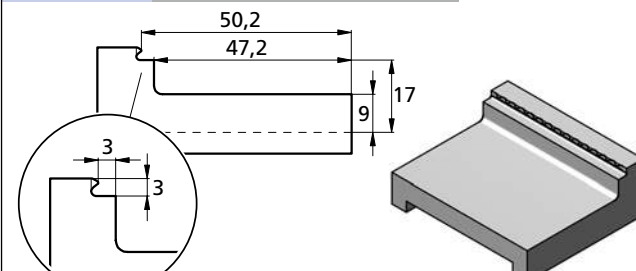

Bestellbeispiel / Ordering example:
3 x MCZ100L50 & 6 x B170 & 1 x NUSS3/8"TX30E14

<p>B170, B172 Spannereich / Clamping width ◀ 0 – 20 mm ▶</p>  <p>B170 HV700 x 0,2 mm</p> <p>B172</p> <p>weich soft 1.7225</p>	<p>Zum Erstellen Ihrer individuellen Formbacke: Schnittzeichnung zum Ermitteln der maximalen Bearbeitungs- profiltiefe</p> <p><i>If a dedicated jaw is being machined:</i> Sectional drawing to determine the maximum machining depth</p>  <p>für / for B170, B172</p>
<p>B175-26 Spannereich / Clamping width ◀ 6 – 26 mm ▶</p>  <p>2,7 3 17</p>	<p>B175-45 Spannereich / Clamping width ◀ 25 – 45 mm ▶</p>  <p>12,3 9,3 9 17</p>
<p>B175-64 Spannereich / Clamping width ◀ 44 – 64 mm ▶</p>  <p>21,7 18,7 9 17</p>	<p>B175-83 Spannereich / Clamping width ◀ 63 – 83 mm ▶</p>  <p>31,2 28,2 9 17</p>
<p>B175-102 Spannereich / Clamping width ◀ 82 – 102 mm ▶</p>  <p>40,7 37,7 9 17</p>	<p>B175-121 Spannereich / Clamping width ◀ 101 – 121 mm ▶</p>  <p>50,2 47,2 9 17</p>

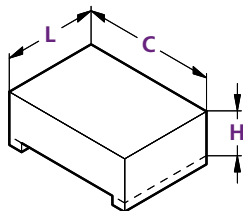

	B170	B172	B175-26	B175-45	B175-64	B175-83	B175-102	B175-121	B175SET
B									
C	70	70	70	70	70	70	70	70	2x B175-26
H	24	24	20	20	20	20	20	20	2x B175-45
L	40	40	40	40	40	40	50	60	2x B175-64
i	HV700 x0,2mm	*	57HRC	57HRC	57HRC	57HRC	57HRC	57HRC	2x B175-83
kg	~0,5	~0,5	~0,34	~0,29	~0,28	~0,25	~0,31	~0,37	2x B175-102



* = weich / soft (1.7225 Vergütungsstahl / Tempering steel)

<p>B173-26 Spannereich / Clamping width ◀ 6 – 26 mm ▶</p>	<p>B173-45 Spannereich / Clamping width ◀ 25 – 45 mm ▶</p>
<p>B173-64 Spannereich / Clamping width ◀ 44 – 64 mm ▶</p>	<p>B173-83 Spannereich / Clamping width ◀ 63 – 83 mm ▶</p>
<p>B173-102 Spannereich / Clamping width ◀ 82 – 102 mm ▶</p>	<p>B176-80 Spannereich / Clamping width ◀ 8 – 80 mm ▶</p> <p>2x Inklusive /Included PRG1003M8</p>
<p>ZK160798M5</p> <p>Extra Zubehör: Schraube zum schnellen Wechseln der Backen</p> <p>Additional accessories: Screw for quick change of jaws</p>	<p>PRG1003M8</p> <p>Bohrbild Hole pattern</p>

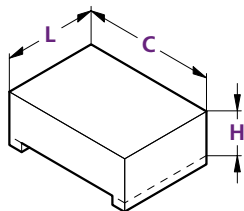

Bestellbeispiel / Ordering example: 2 x B173-26

B	B173-26	B173-45	B173-64	B173-83	B173-102	B176-80	B173SET
C	70	70	70	70	70	70	2x B173-26
H	24	24	24	24	24	20	2x B173-45
L	40	40	40	40	50	40	2x B173-64
i	HV700	HV700	HV700	HV700	HV700	HV700	2x B173-83
	x0,2mm	x0,2mm	x0,2mm	x0,2mm	x0,2mm	x0,2mm	2x B173-102
kg	~0,31	~0,32	~0,32	~0,28	~0,34	~0,4	

Separat bestellen / Order separately

Doppelte Spannung – doppelt effizient
Twice the clamping – twice the efficiency

Art. Nr.	kg	Backen Jaws	A = 2 x
B172-MB	~0,3	B172	variabel

weicher Stahl
soft steel (1.7225)

B173-MB	~0,3	B173-45	10 – 17 mm
	HV700 x 0,2mm	B173-64	17 – 27 mm

B173-83 27 – 37 mm

B173-102 36 – 46 mm

B175-121 46 – 55 mm

B175-MB	~0,3	B175-45	8 – 16 mm
	57HRC	B175-64	16 – 26 mm

B175-83 25 – 35 mm

B175-102 35 – 45 mm

B175-121 45 – 54 mm

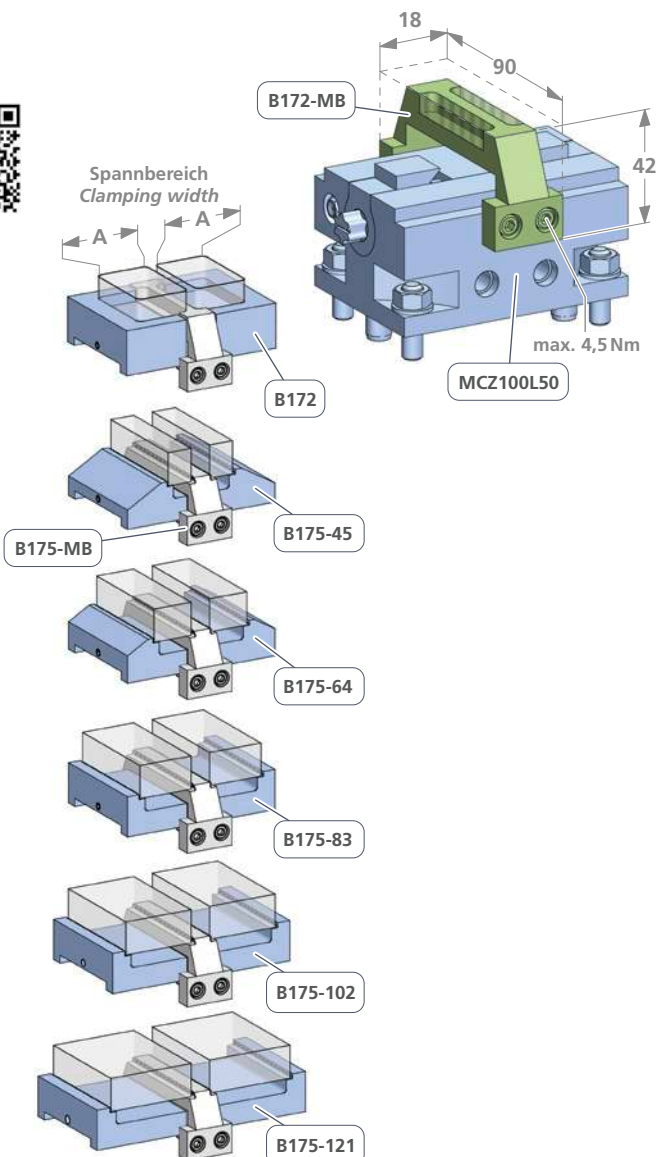

Die Anschlagbrücken **B172-MB**, **B173-MB** und **B175-MB** können in Kombination mit den Zentrischspannern PCZ100L50 / MCZ100L50 als Doppelspanner eingesetzt werden.

The **B172-MB**, **B173-MB**, and **B175-MB** stop bridges can be used as double clamps in combination with the PCZ100L50 / MCZ100L50 self centering vise.

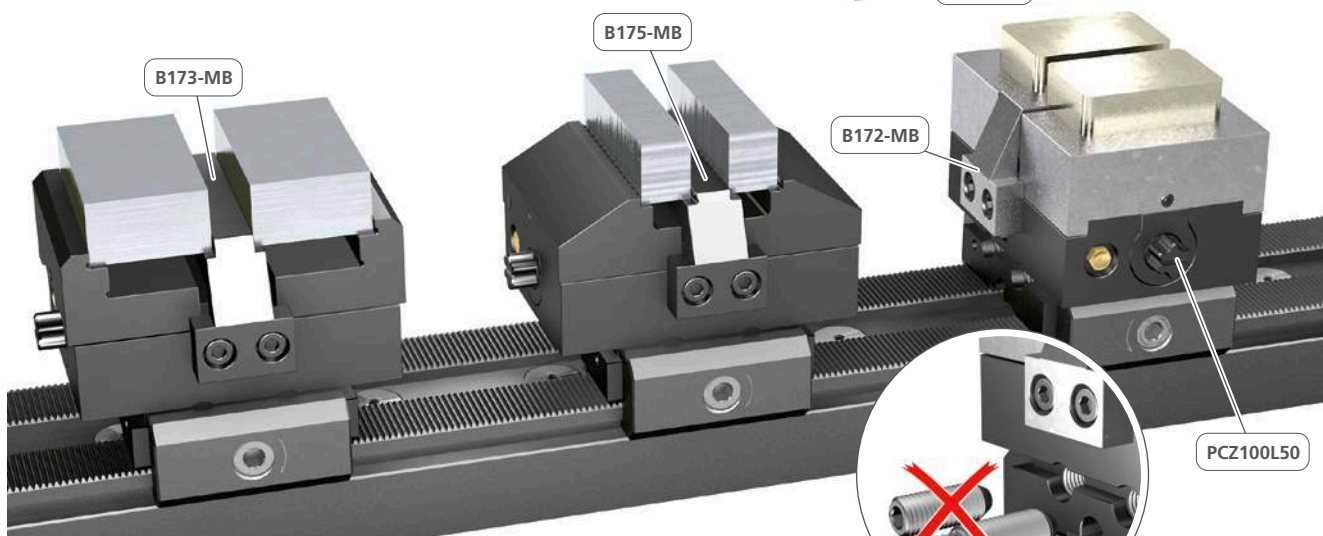

Folgende Spannbacken sind dazu nicht geeignet.

The following clamping jaws are not suitable for this purpose.

B170, **B173-26**, **B175-26**, **B176-80**

ACHTUNG / CAUTION

Beim Einsatz der Anschlagbrücke muss der Spanner schwimmend eingestellt werden, dabei werden die vier Zentrierschrauben entfernt.

When using the stop bridge, the tensioner must be adjusted to float, removing the four centring screws in the process.

Montageanleitung der Anschlagbrücke auf dem Mini-Zentrischspanner
Operating instructions for this pneumatic self centering vise



MINI

Zentrischspanner mit Anschlagbrücke
Self centering vise with center stop

triCENTRO

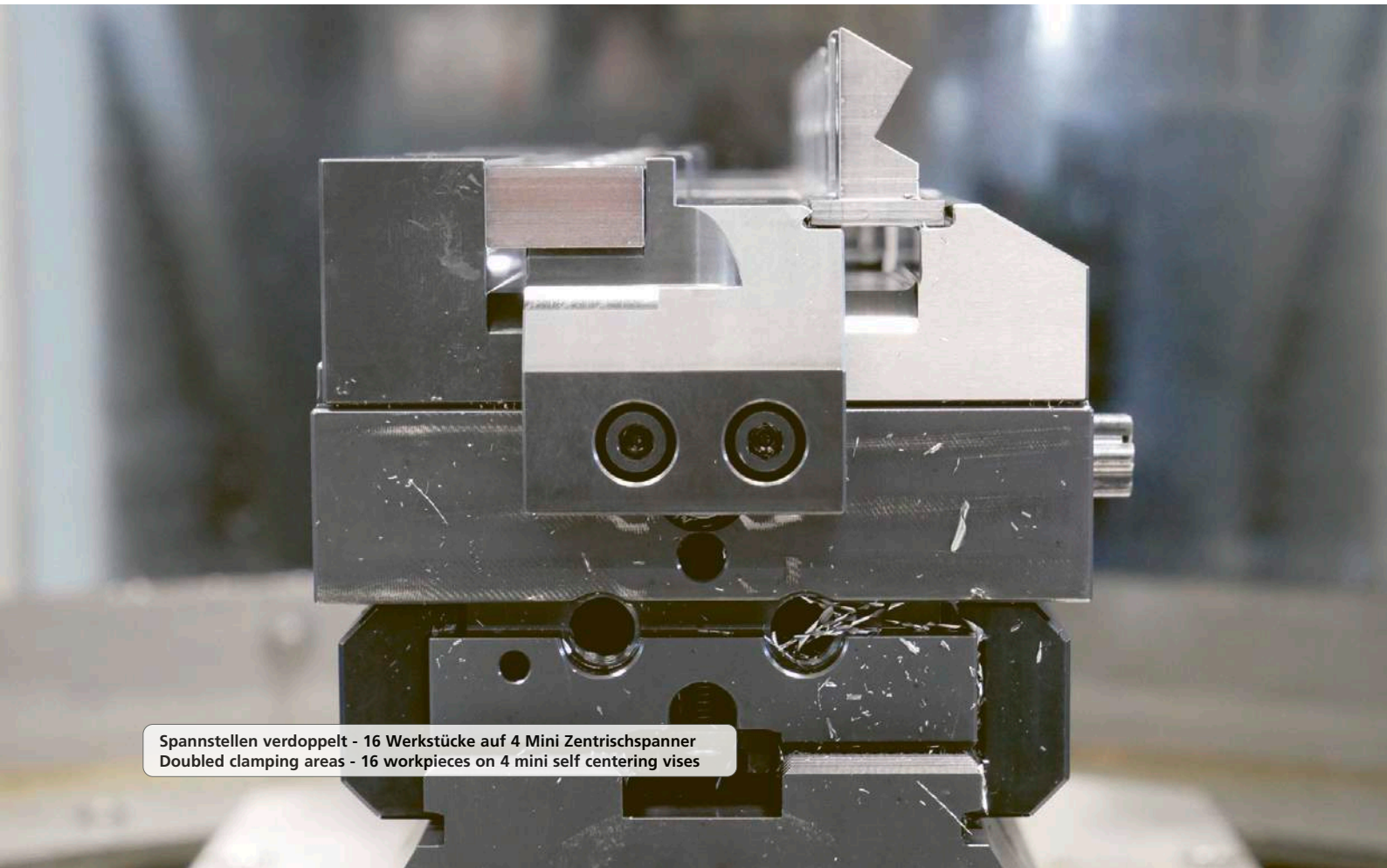
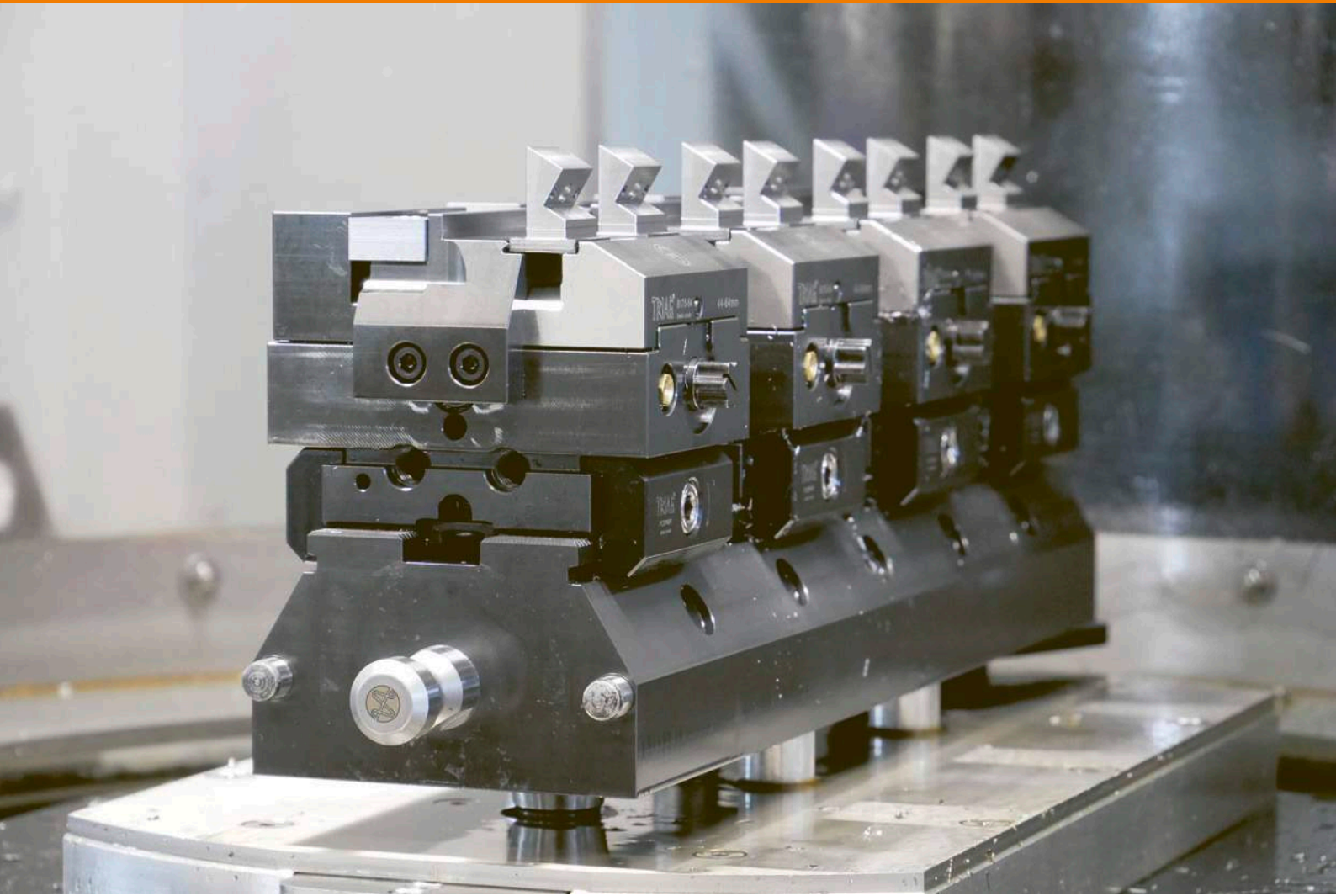

Spannstellen verdoppelt - 16 Werkstücke auf 4 Mini Zentrischspanner
Doubled clamping areas - 16 workpieces on 4 mini self centering vises

Diese Spannbacken sind für die Innenspannung geeignet.
These clamping jaws are suitable for internal clamping.

Diese Spannbacken sind für die Spannung mit der Anschlagbrücke geeignet.
These clamping jaws are suitable for clamping with the stop bridge.

PCZ100L50 MCZ100L50 p. 130 B172-MB PCZS2439-ID-SET p. 126

14 verschiedene Backenvarianten passend zu dieser Schnellwechselschnittstelle.
More than 14 different jaw modules to match this rapidly changing interface.

SPACEGRIP II

spaceGRIP II

Ein einzigartig auf Modulbauweise ausgelegtes Spannkonzzept für den Einsatz der Zentrischspanner **MCZ100L50**.

Es können 4, 8 oder gar 12 Spanner, je nach Wunsch, eingesetzt werden. Das Ganze ist so modular wie ein «Lego»-Baukasten-System. Wieder stehen Prägebacken, weiche Backen und zusätzlich Stufen- und Universalbacken zur Verfügung. Sogar das Zentrum der einzelnen Spannstöcke kann eingestellt werden.

spaceGRIP II

A unique clamping concept with modular construction design for using the self-centering vice **MCZ100L50**.

Four, eight or even twelve clamping vices can be used as needed. The whole system is modular like a «Lego» building kit. Again, stamping jaws, soft jaws and universal as well as stepped jaws are available. Even the centre of the individual vices can be adjusted.

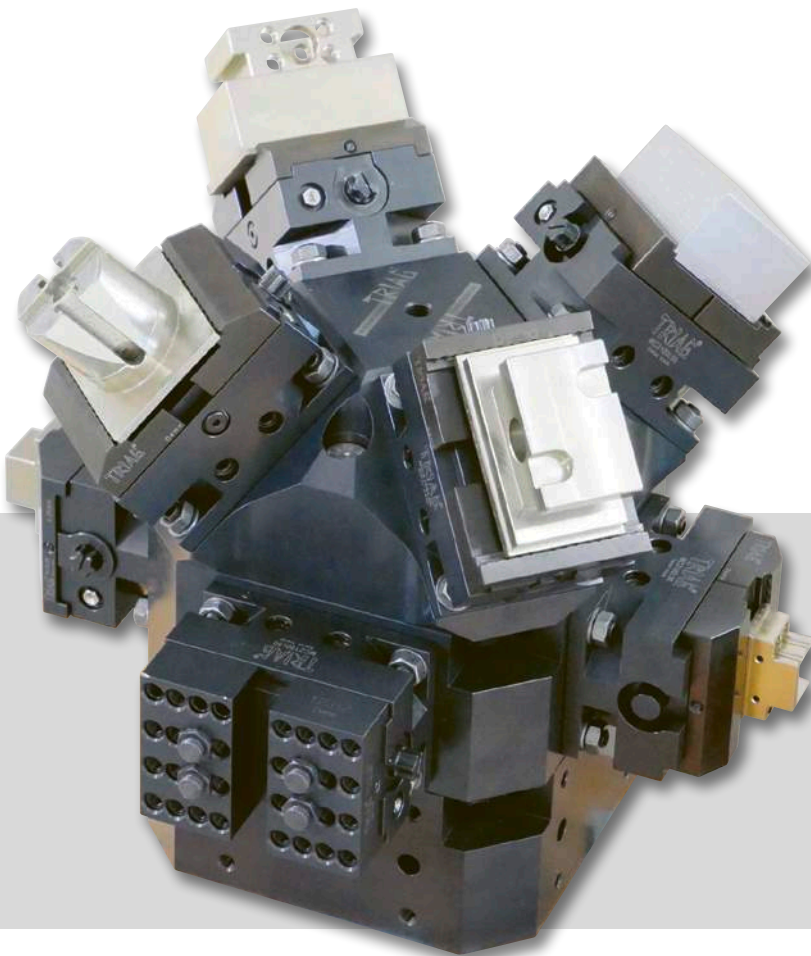

SPACEGRIP II

SPACEGRIP II

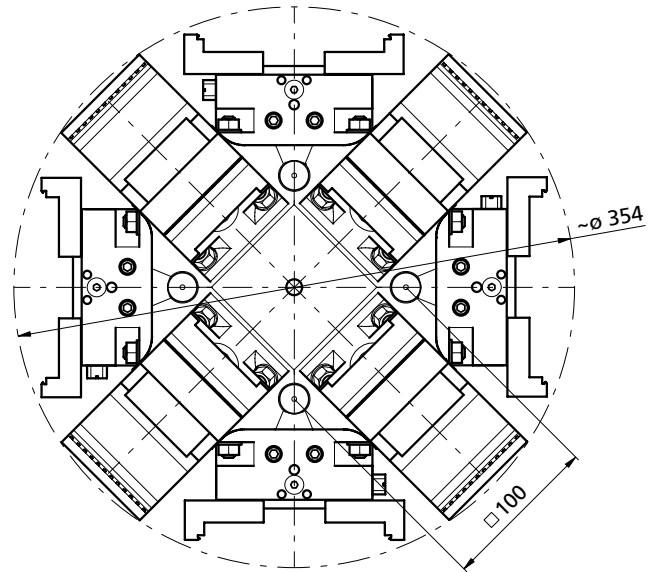
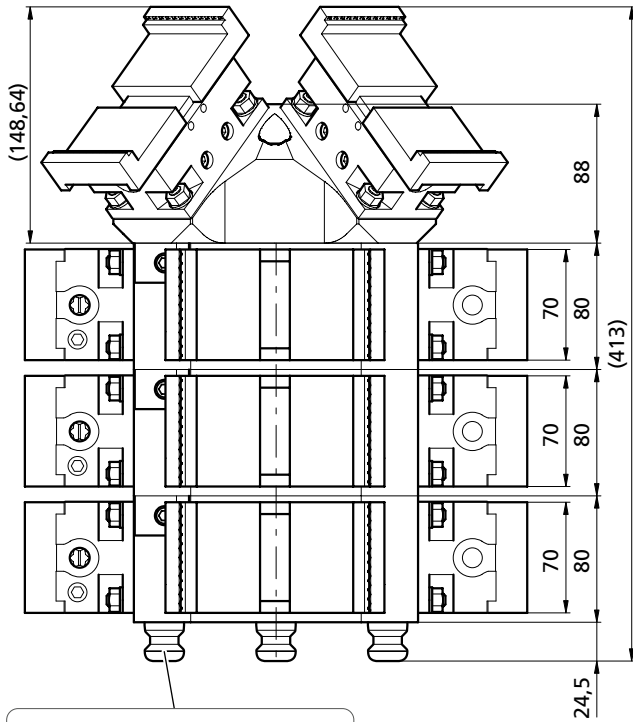

OPP-Schnittstelle Nullpunkt-System
OPP interface Zero-point system

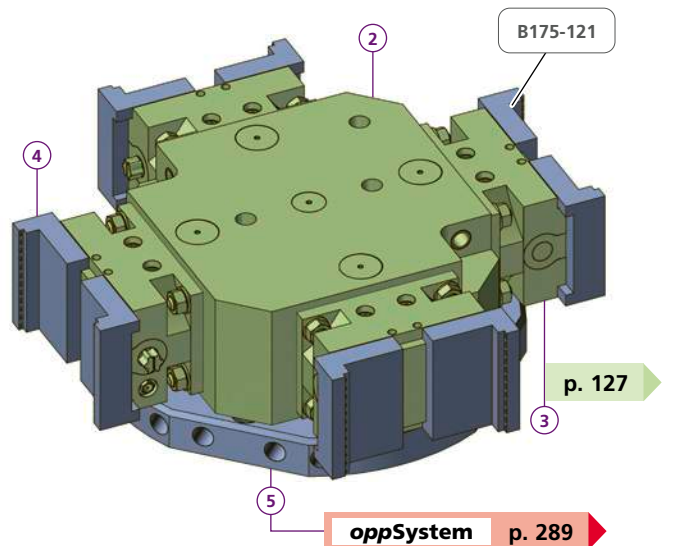
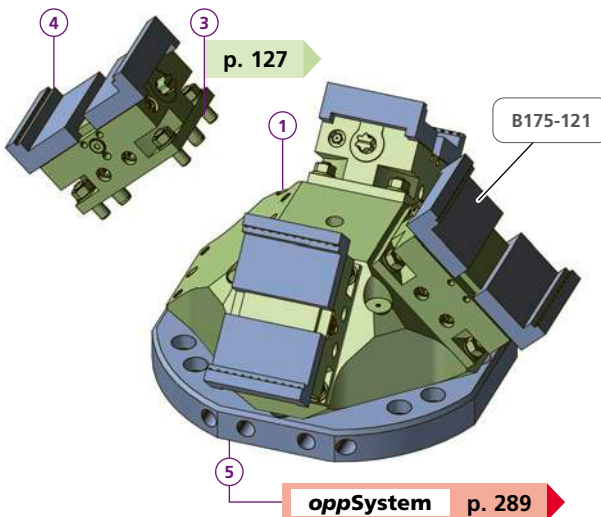

5AXMCZ100-45-4	
1	1x TS160110
3	4x MCZ100L50
4	8x p. 128 - 129
5	1x TB160379
kg	~26



Detailzeichnung zu dieser Schnittstelle
Detail drawing to interface

5AXMCZ100-90-4	
2	1x TS160111
3	4x MCZ100L50
4	8x p. 128 - 129
5	1x TB160379
kg	~28,7



Detailzeichnung zu dieser Schnittstelle
Detail drawing to interface

Separat bestellen / Order separately

Bestellbeispiel / Ordering example : 1 x 5AXMCZ100-90-4 & 8 x B175-121

SPACEGRIP II

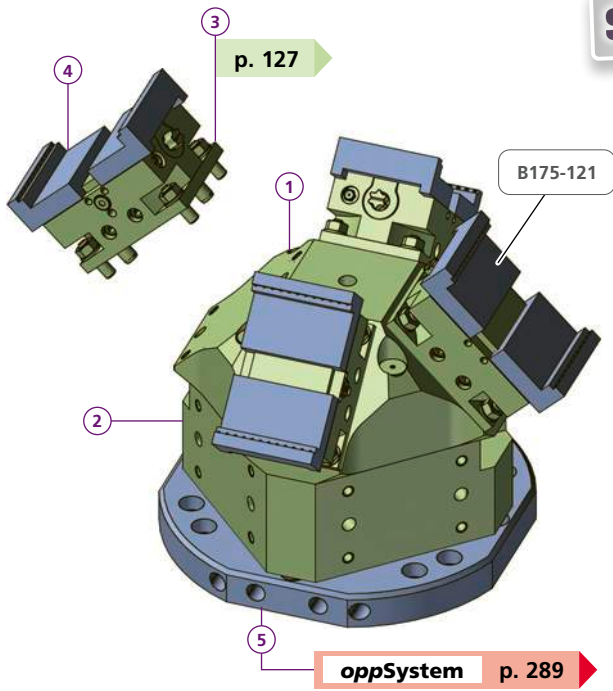

5AXMCZ100-45-4H	
1	1x TS160110
2	1x TS160111
3	4x MCZ100L50
4	8x —————
5	1x TB160379
kg	~41,2



Detailzeichnung zu dieser Schnittstelle
Detail drawing to interface

p. 128 - 129

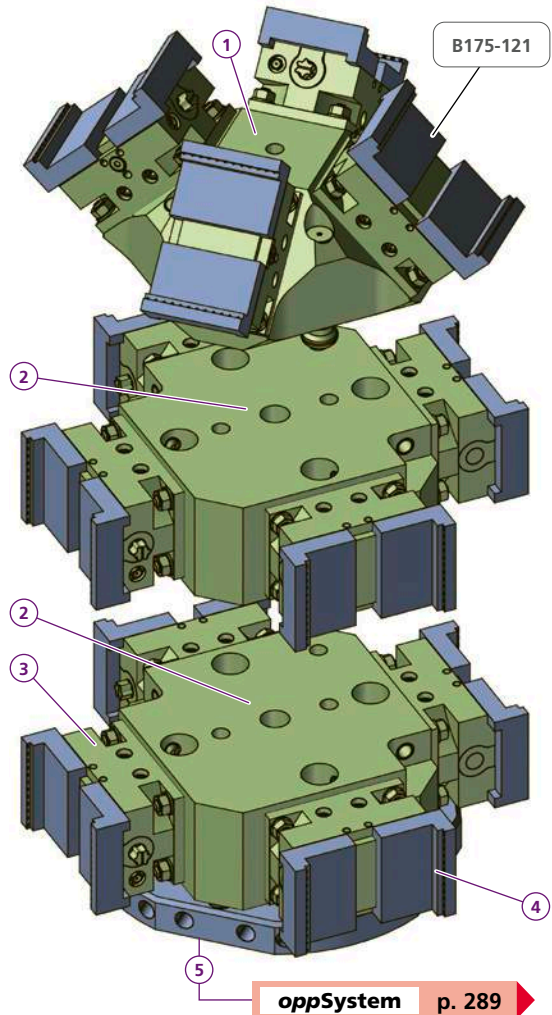

5AXMCZ100-45-12	
1	2x TS160110
2	1x TS160111
3	12x MCZ100L50
4	24x —————
5	1x TB160379
kg	~83,3



Detailzeichnung zu dieser Schnittstelle
Detail drawing to interface

p. 128 - 129

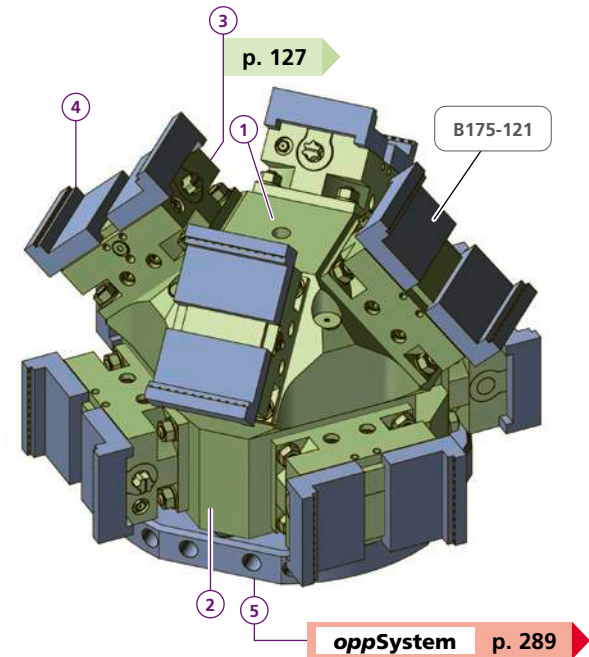

5AXMCZ100-45-8	
1	1x TS160110
2	1x TS160111
3	8x MCZ100L50
4	16x —————
5	1x TB160379
kg	~54,6



Detailzeichnung zu dieser Schnittstelle
Detail drawing to interface

p. 128 - 129

Bestellbeispiel / Ordering example: 1 x 5AXMCZ100-45-8 & 16 x B175-121

SPACEGRIP II-3 

Art. Nr.	kg
5AXMCZ100-45-3	~18
5AXMCZ100-45-3H	~35
5AXMCZ100-45-6	~43



Bei dieser Pyramidenlösung ist die Zugänglichkeit der Spindel beim Bearbeiten von Werkstücken sehr gut.

With this pyramid solution, the accessibility of the spindle is very good when machining workpieces.

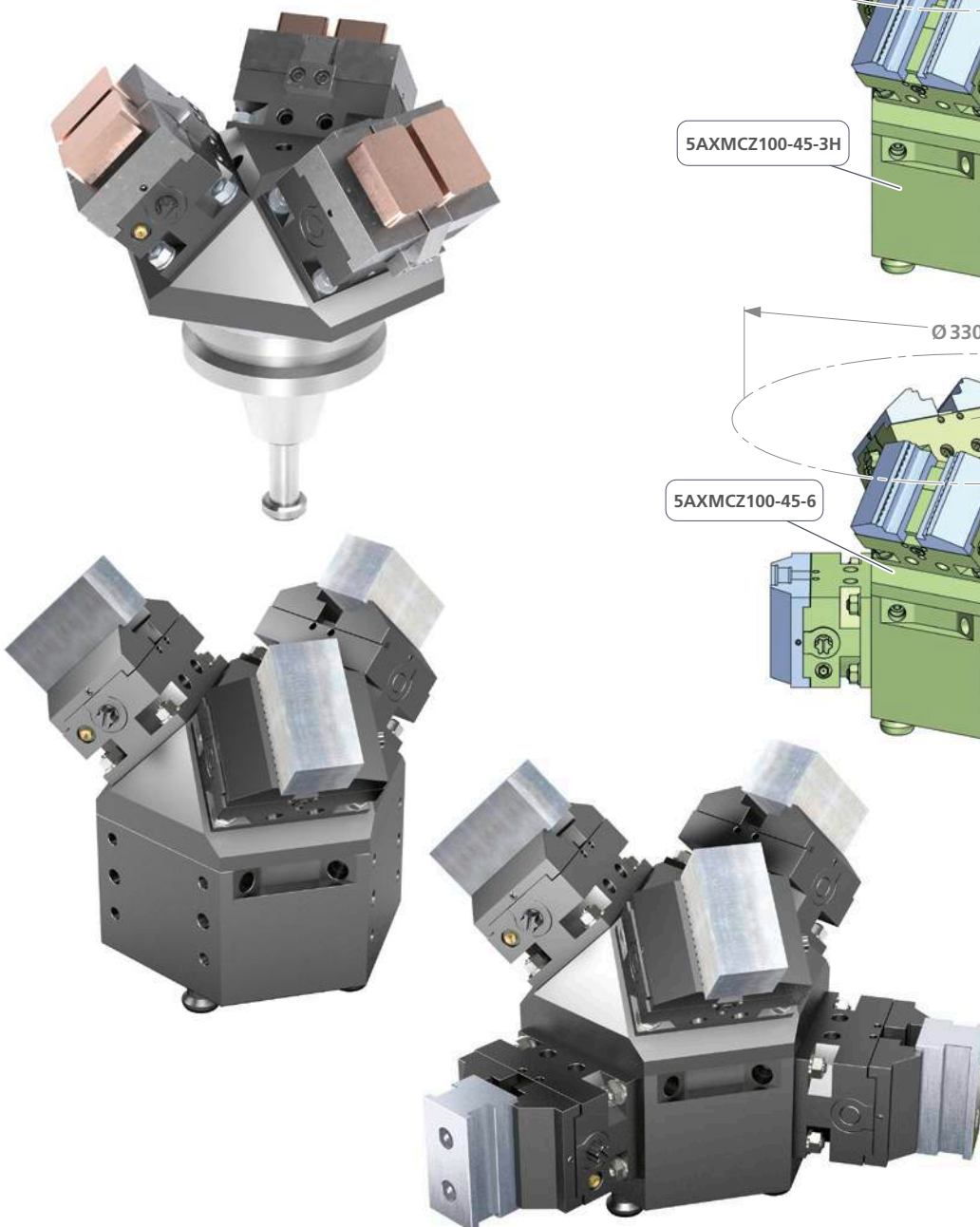
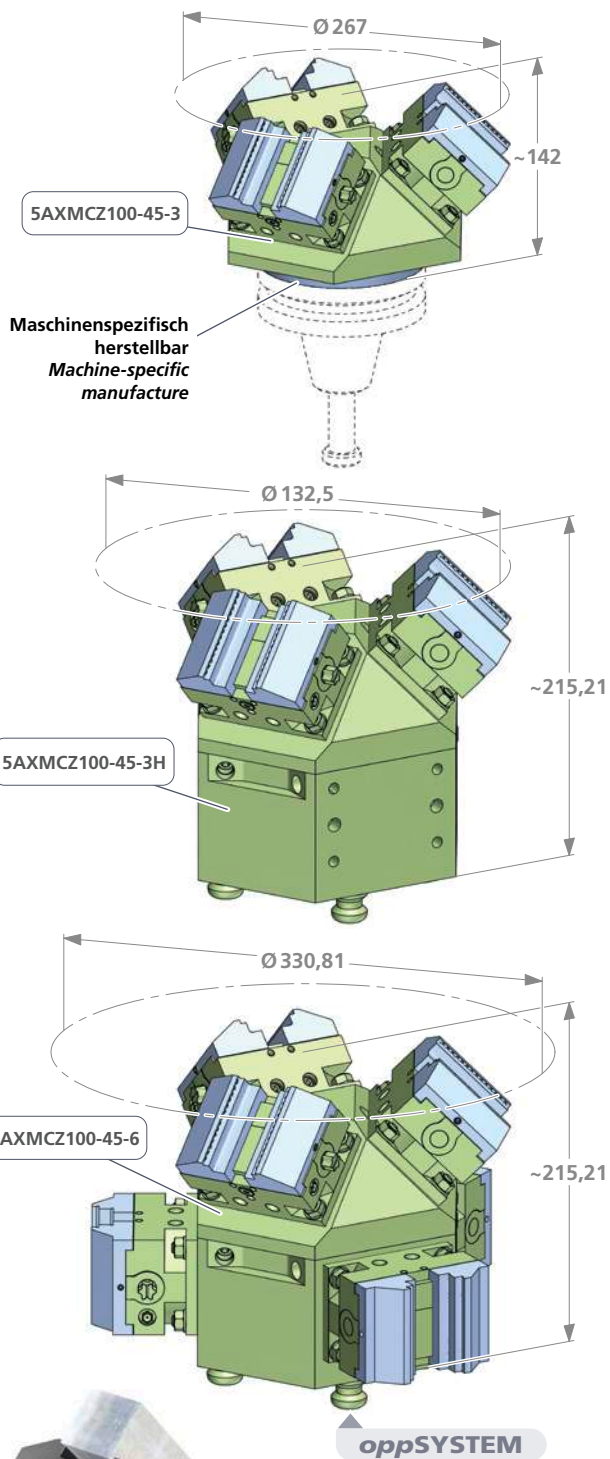

Durchgehend modular!

Clevere Zentrischspanner passen sich der Maschine, den Werkstücken und den Anforderungen an.

Throughout modular!

Clever self centering vises which adapts to the machine, the workpiece and the requirements.

X

Spannkrafterhaltung und Nachfederung

Spring loaded mechanism to maintain clamping force

M

Mehr als **64** verschiedene Backenvarianten passend zu dieser Schnellwechelschnittstelle.

More than 64 different jaw modules to match this rapidly changing interface.

Q

Schnellwechselbacken

Spannkrafterhaltung und Nachfederung

Quick-change jaws

Spring loaded mechanism to maintain clamping force

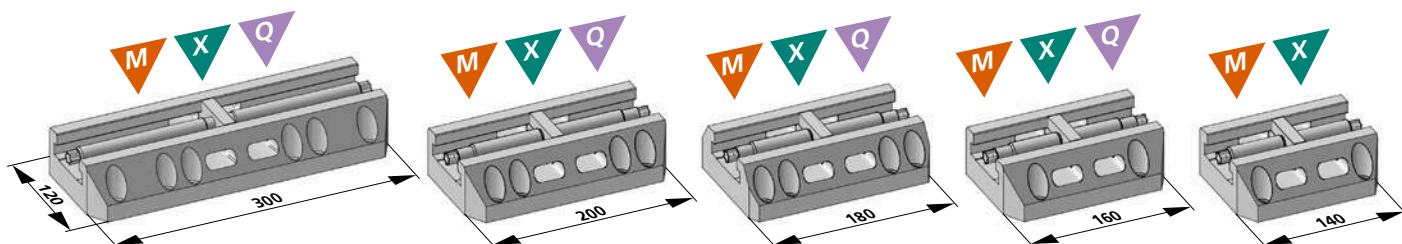
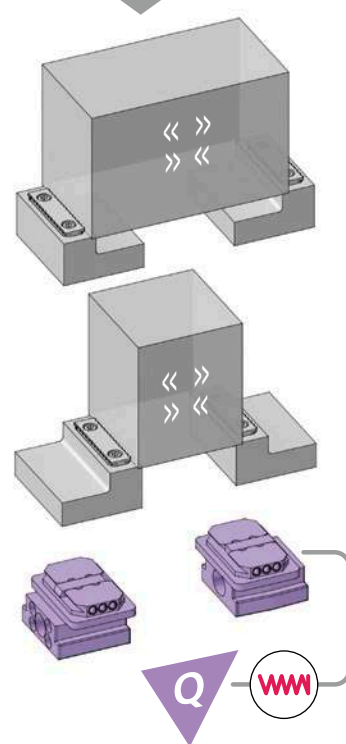
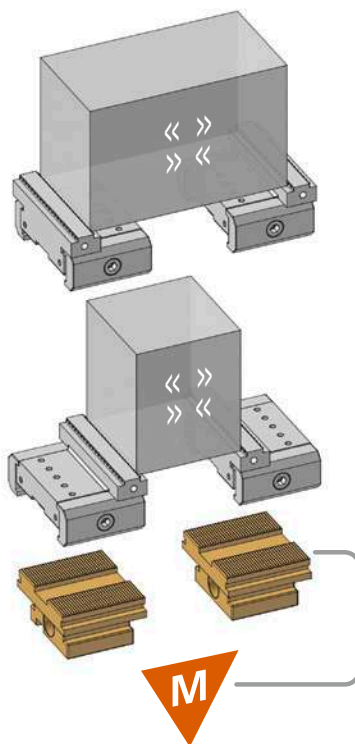
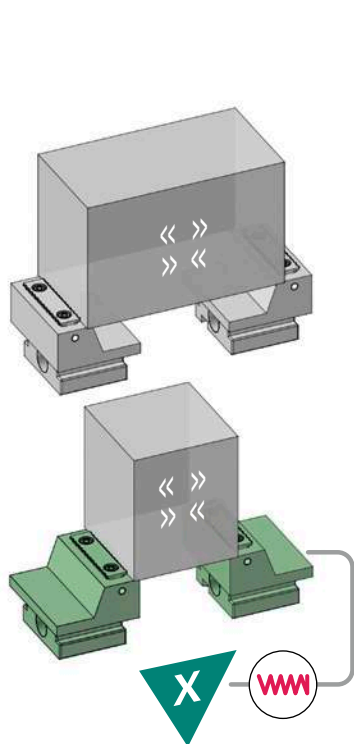

Art. Nr.	kg
ZS X 300L50UPRG	~10,65
ZS X 200L50UPRG	~8,8
ZS X 180L50UPRG	~8,1
ZS X 160L50UPRG	~7,7
ZS X 140L50UPRG	~7,1

Art. Nr.	kg
ZS M 300L50UPRG	~10,5
ZS M 200L50UPRG	~7,4
ZS M 180L50UPRG	~6,9
ZS M 160L50UPRG	~6,4
ZS M 140L50UPRG	~5,7

Art. Nr.	kg
ZS Q 300L50UPRG	~11,1
ZS Q 200L50UPRG	~8,1
ZS Q 200L50UPRG	~8,1
ZS Q 180L50UPRG	~7,5
ZS Q 160L50UPRG	~7,0

Zentrischspanner mit Spannkrafterhaltung und Direkt-Prägebacken

- ✓ für die erste Aufspannung mittels Direkt-Prägebacken ab 3 mm
- ✓ Einzigartiges integriertes Federpaket
- ✓ Beste Zugangs-Möglichkeit
- ✓ für OP10 und OP20 ausgelegt
- ✓ Bestens geeignet für 5-Achsen Maschinen mit kleinerem Tisch
- ✓ Bestens geeignet für den Einsatz auf Rundtischen

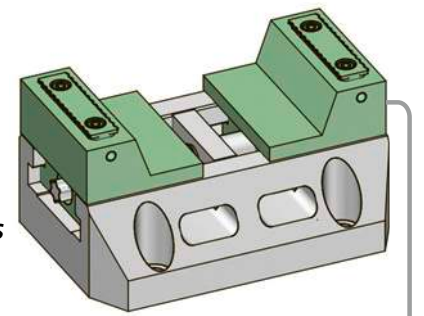

Self-centering vise with spring loaded mechanism and direct stamping jaws

- ✓ for the first clamping using direct stamping jaws from 3 mm
- ✓ Unique integrated spring package
- ✓ Best access option
- ✓ Designed for OP10 and OP20
- ✓ Ideally suited for 5-axis machines with smaller tables
- ✓ Ideally suited for use on rotary tables

Zentrischspanner für den Einsatz mit Power Clamp Modulen

- ✓ Höchste Modularität, alle Power Clamp Module können eingesetzt werden
- ✓ Schneller Backenwechsel (eine Schraube lösen und Modul nach oben abheben)
- ✓ Backen von 19 bis 150 mm
- ✓ weiche Backen
- ✓ Direktprägebacken und Bearbeitung ab 3 mm

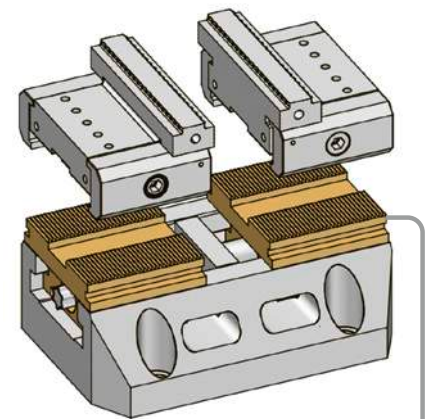

Self-centering vice for use with Power Clamp modules

- ✓ Highest modularity, all Power Clamp modules can be used
- ✓ Quick jaw change (loosen one screw and lift the module up)
- ✓ Jaws from 19 to 150 mm
- ✓ soft jaws
- ✓ Direct stamping jaws, machining from 3 mm

Zentrischspanner für den Einsatz von Schnellwechselbacken

- ✓ Schnellwechselbacken (werden per Hand auf dem Spanner eingeklinkt)
- ✓ Weiche Backen zum selbst bearbeiten
- ✓ Direktprägebacken für OP10
- ✓ Einzigartiges integriertes Federpaket
- ✓ Für Rohteile können pendelnde Schlitten (P) eingesetzt werden

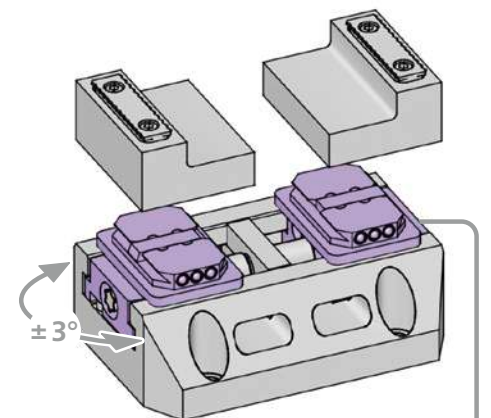

Self-centering vice for the use of quick-change jaws

- ✓ Quick-change jaws (clicked on the vise by hand)
- ✓ Soft jaws for individual machining
- ✓ Direct stamping jaws for OP10
- ✓ Unique integrated spring package
- ✓ Pendulum slides (P) can be used for unmachined parts

Drehmoment Torque		Spannkraft Workholding force			Gut zu Wissen Good to know
Nm	(lb-ft)	~daN	~(lb)	~t	
10	7,4	= 200	440	0,2	Diese Spannkräfte werden für den Dauerbetrieb empfohlen! These clamping forces are recommended for continuous operation!
20	14,8	= 500	1'102	0,5	
30	22,2	= 1'000	2'204	1,0	
40	29,6	= 1'300	2'866	1,3	
50	37,0	= 1'600	3'527	1,6	
60	44,4	= 1'800	3'968	1,8	Für kurzfristige Anwendung For short-term application
70	51,8	= 2'100	4'629	2,1	

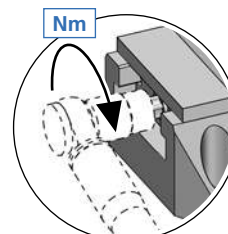

ZSM200L50 & PAND94-49PRG-A1

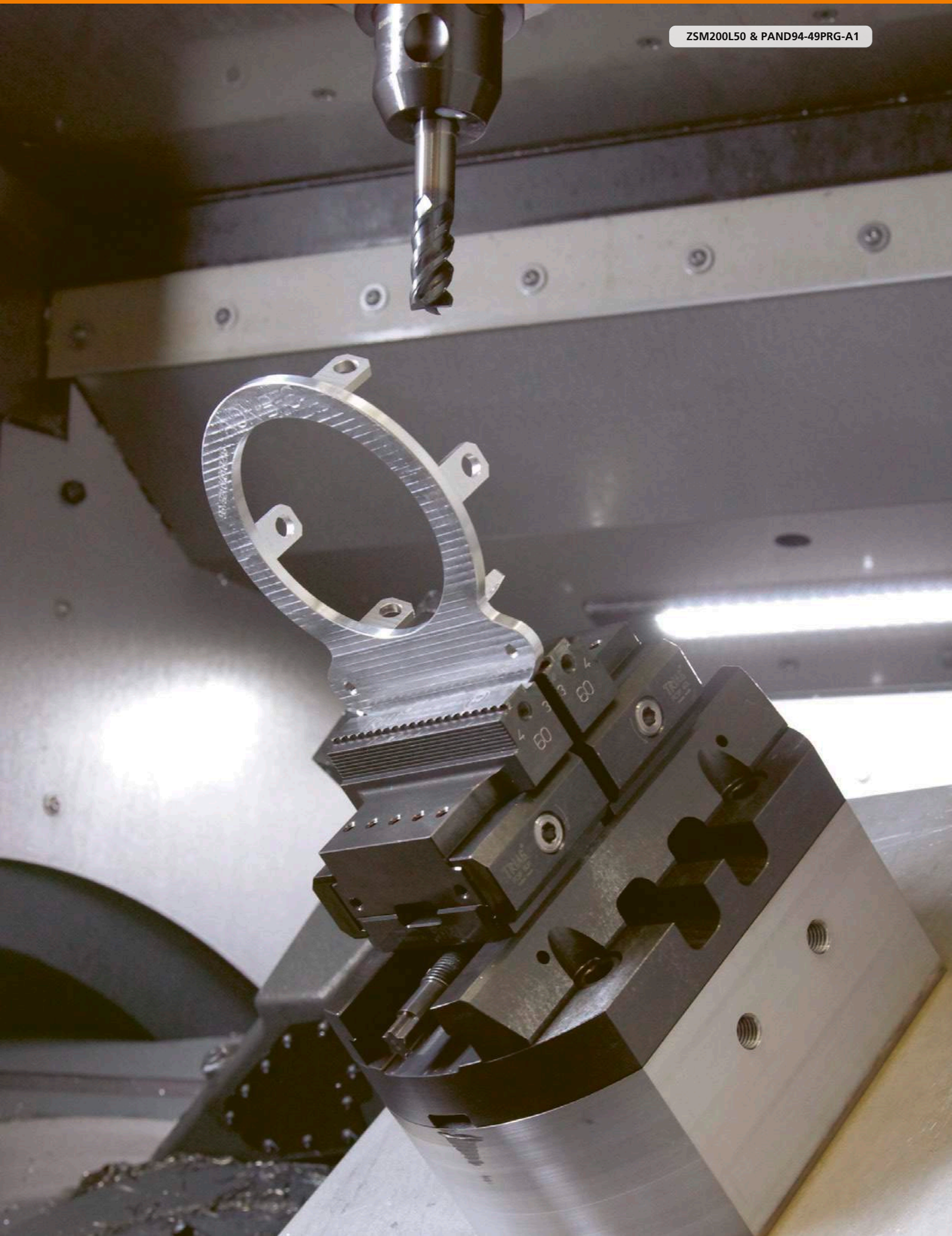

Direkt-Prägebacken

Bei knapp gespannten Werkstücken, speziell in weichen Materialien, wie Alu und Rostfrei aber auch in praktisch allen anderen Materialien, besteht das Problem, dass sich die Werkstücke freiwiegeln! Dies vor allem bei weit auskragenden Werkstücken bei der 5-Achsen Bearbeitung, selbst wenn vorgeprägt wird.

Triag International hat deshalb einen nachfedernden Zentrisch Spannstock entwickelt, welcher ein Freiwiegeln der Werkstücke mittels Nachfederung verhindert.

Bei diesem patentiertem System wird mittels Tellerfedern eine Backe des Zentrischspannstockes nachgeschoben. So wird der Spanndruck aufrechtgehalten. Die Einspanntiefe ist im Normalfall 3 mm, kann aber verstellt werden von ca. 1,8 bis 6 mm. Das Werkstück kann sich so praktisch nicht freiwiegeln.

Das heisst, man hat durchwegs die gleichen Bedingungen und das Werkstück hat während der Bearbeitung weniger Vibrationen und bewegt sich nicht. Oberfläche und Genauigkeit verbessern sich und sind konstanter.

Direct spring loaded stamping jaws

This patented self centering vise is unique, as it can be used for direct stamping the blanks. It is different to others as the teeth bite into the raw material and even under vibrations, one of the two jaws will continuously move forward. This will hold the workpiece with the same force and strength as in the beginning.

The problem in the past was that the other systems in the market were getting loose during heavy machining and accuracy was difficult to achieve.

Especially in soft materials such as alu and soft steels it has a great performance. Usually the workpiece is clamped only 3 mm but this height can be changed from 1,8 to 6 mm if necessary.

Spannkrafterhaltung und Nachfederung
Spring loaded mechanism to maintain clamping force

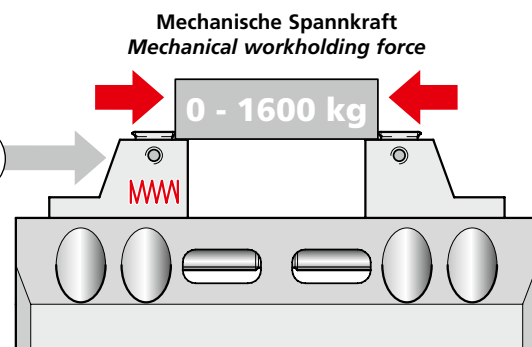

MANF58-14W25 microCLAMP p. 176

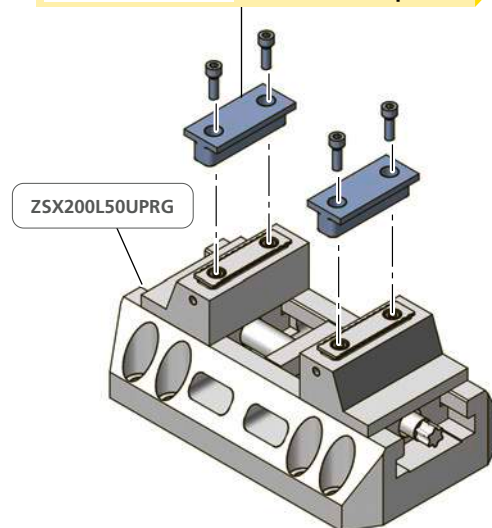

Drehmoment Torque		Spannkraft Workholding force			Gut zu Wissen Good to know
Nm	(lb-ft)	~daN	~(lb)	~t	
10	7,4	= 200	440	0,2	Diese Spannkräfte werden für den Dauerbetrieb empfohlen! These clamping forces are recommended for continuous operation!
20	14,8	= 500	1'102	0,5	
30	22,2	= 1'000	2'204	1,0	
40	29,6	= 1'300	2'866	1,3	
50	37,0	= 1'600	3'527	1,6	
60	44,4	= 1'800	3'968	1,8	Für kurzfristige Anwendung For short-term application
70	51,8	= 2'100	4'629	2,1	

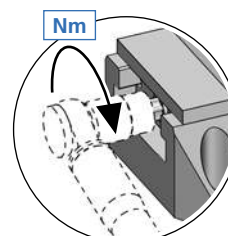

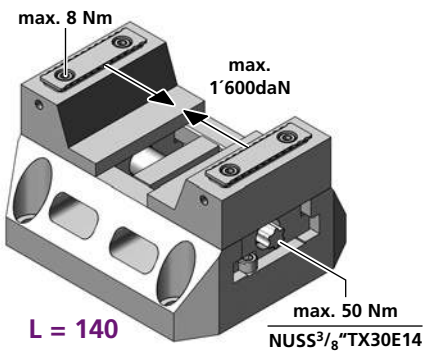
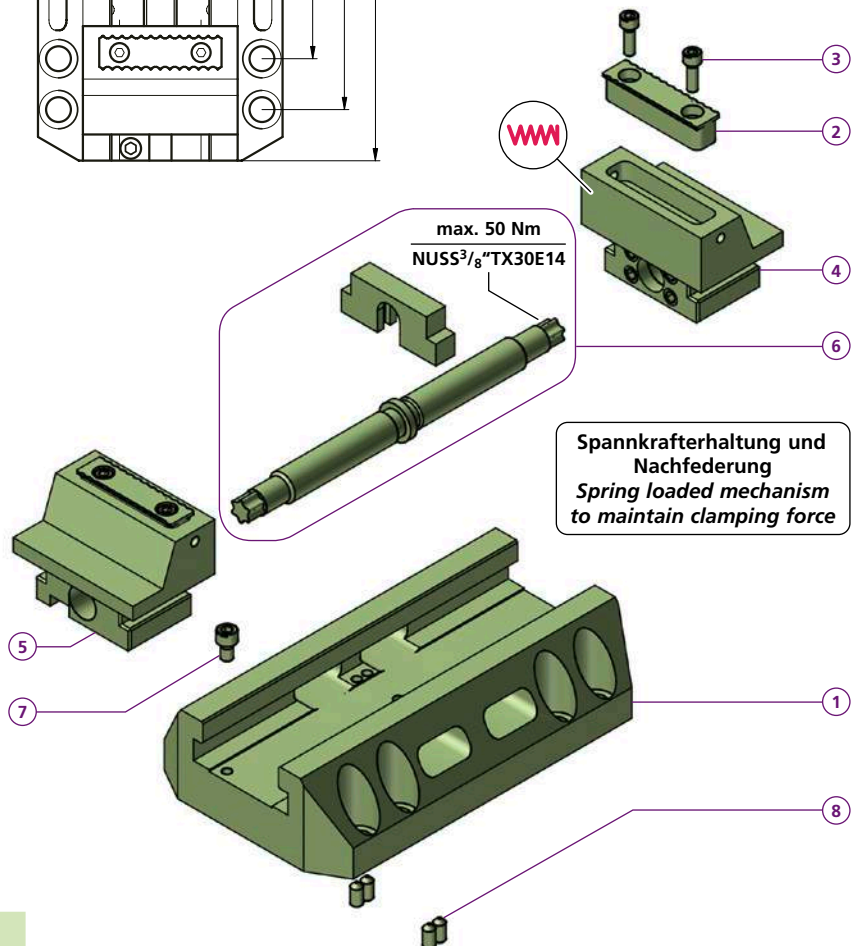
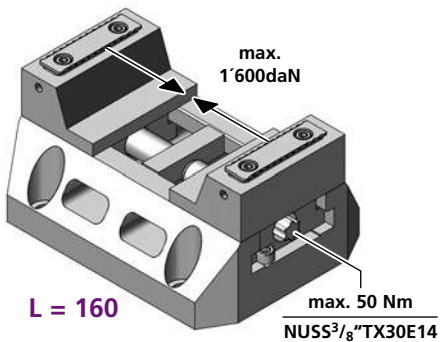
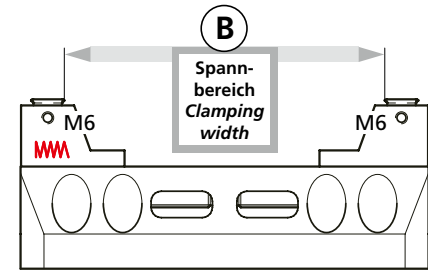
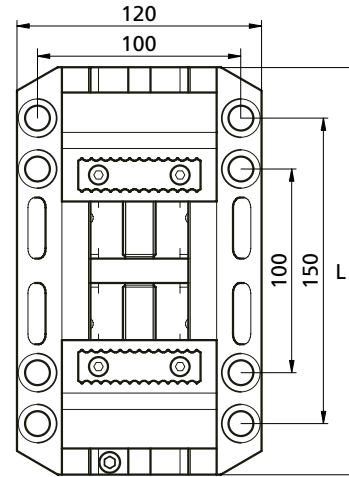
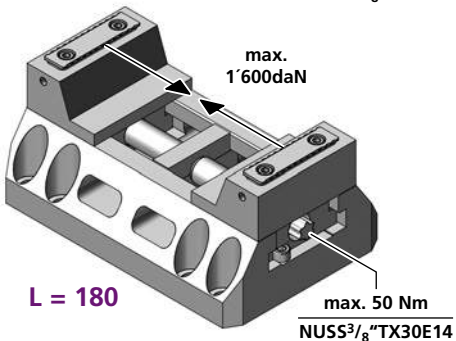
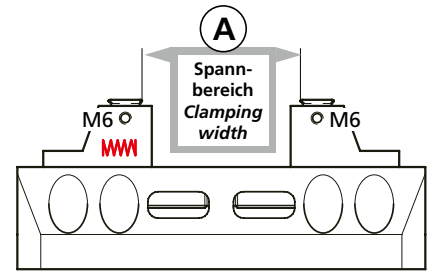
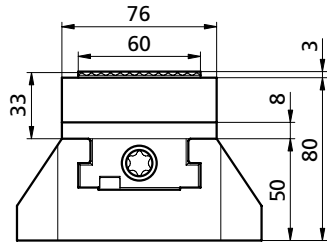
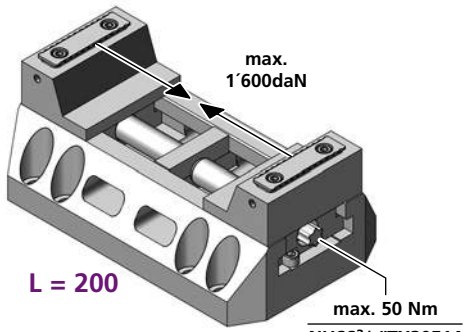

ZSX200L50UPRG	
1	1x TK150025
2	2x MAND58-14PRG
3	4x M5X16ISO4762
4	1x ZB150787
5	1x ZB150786
6	1x PCS16TR200SET
7	1x M6X10ISO4762
8	4x M6X16DIN914
L	= 200
A	10 – 124 mm
B	62 – 178 mm
kg	~8,8

ZSX180L50UPRG	
1	1x TK150523
6	1x PCS16TR180SET
L	= 180
A	10 – 104 mm
B	62 – 158 mm
kg	~8,1

ZSX160L50UPRG	
1	1x TK150522
6	1x PCS16TR160SET
L	= 160
A	10 – 84 mm
B	62 – 138 mm
kg	~7,7

ZSX140L50UPRG	
1	1x TK150521
6	1x PCS16TR140SET
L	= 140
A	10 – 64 mm
B	62 – 118 mm
kg	~7,1

Drehmoment und Spannkraft siehe Seite 140
Torque and clamping force see page 140

NUSS3/8"TX30E14

WICHTIG!
Bitte separat bestellen
IMPORTANT!
Please order separately



Bestellbeispiel / Ordering example:
3 x ZSX200L50UPRG & 1 x NUSS3/8"TX30E14

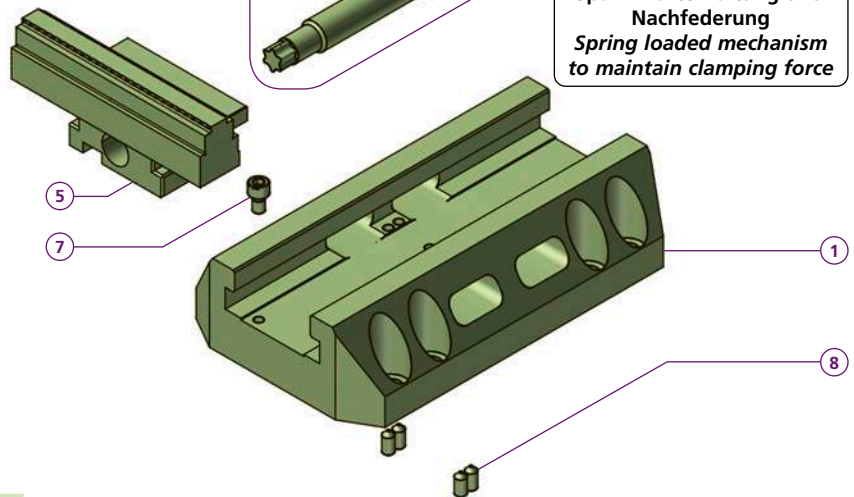
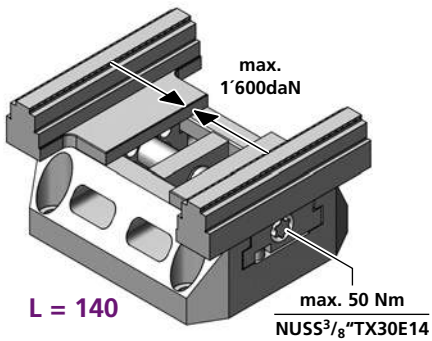
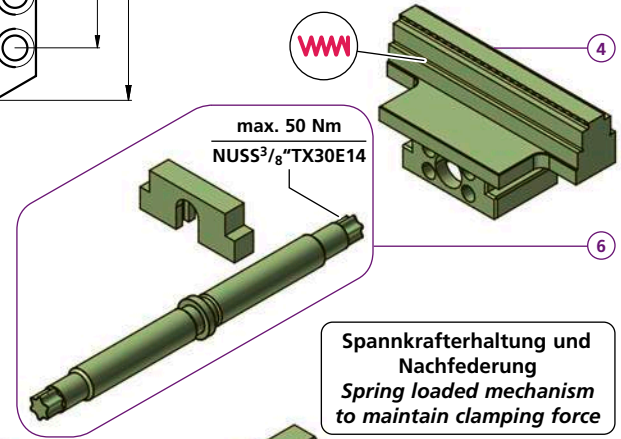
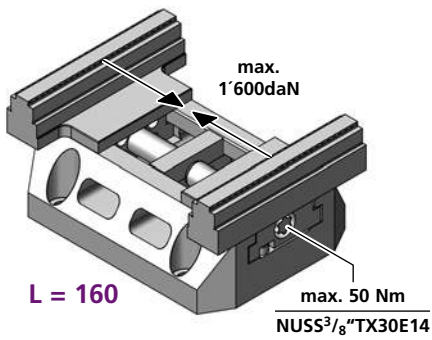
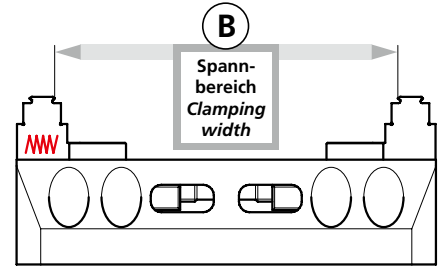
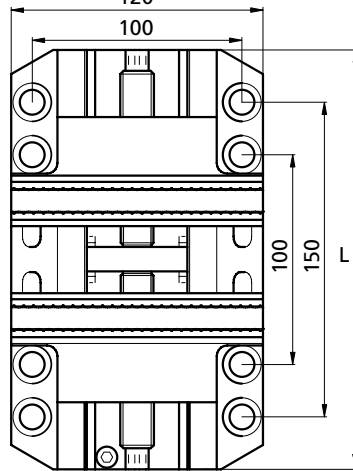
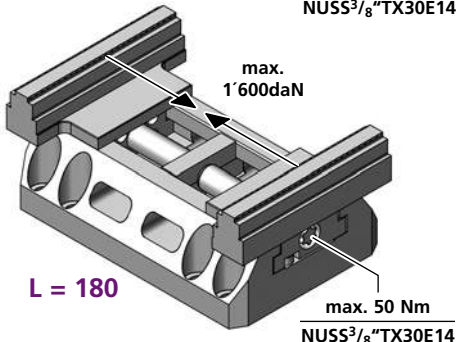
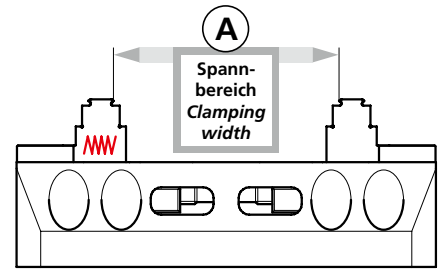
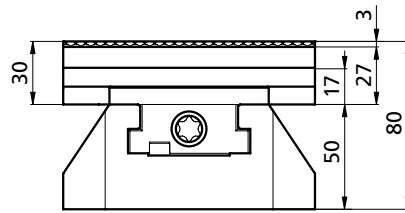
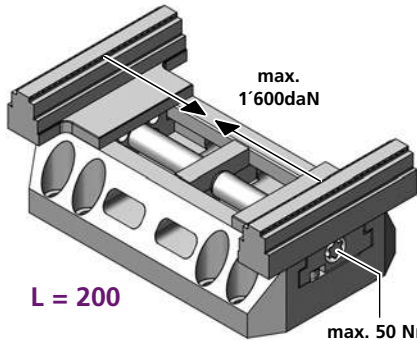

ZSX200L50PRG120	
1	1x TK150025
4	1x ZB170050
5	1x TB170051
6	1x PCS16TR200SET
7	1x M6X10ISO4762
8	4x M6X16DIN914
L	= 200
A	14 – 130 mm
B	70 – 186 mm
kg	~7,7

ZSX180L50PRG120	
1	1x TK150523
6	1x PCS16TR180SET
L	= 180
A	14 – 110 mm
B	70 – 166 mm
kg	~7,2

ZSX160L50PRG120	
1	1x TK150522
6	1x PCS16TR160SET
L	= 160
A	14 – 90 mm
B	70 – 146 mm
kg	~6,6

Drehmoment und Spannkraft siehe Seite 140
Torque and clamping force see page 140

NUSS3/8"TX30E14
WICHTIG!
Bitte separat bestellen
IMPORTANT!
Please order separately

Bestellbeispiel / Ordering example:
3 x ZSX200L50PRG120 & 1 x NUSS3/8"TX30E14

Separat bestellen / Order separately

Drehmoment Torque		Spannkraft Workholding force			Gut zu Wissen Good to know
Nm	(lb-ft)	~daN	~(lb)	~t	
10	7,4	= 200	440	0,2	Diese Spannkraften werden für den Dauerbetrieb empfohlen! <i>These clamping forces are recommended for continuous operation!</i>
20	14,8	= 500	1'102	0,5	
30	22,2	= 1'000	2'204	1,0	
40	29,6	= 1'300	2'866	1,3	
50	37,0	= 1'600	3'527	1,6	
60	44,4	= 1'800	3'968	1,8	Für kurzfristige Anwendung <i>For short-term application</i>
70	51,8	= 2'100	4'629	2,1	

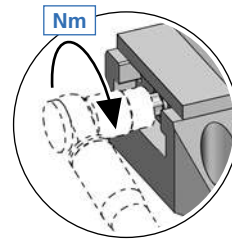

NEWS →

PowerCLAMP

Anschlagmodul mit Prägeeinsätzen
End modul with embossed inserts

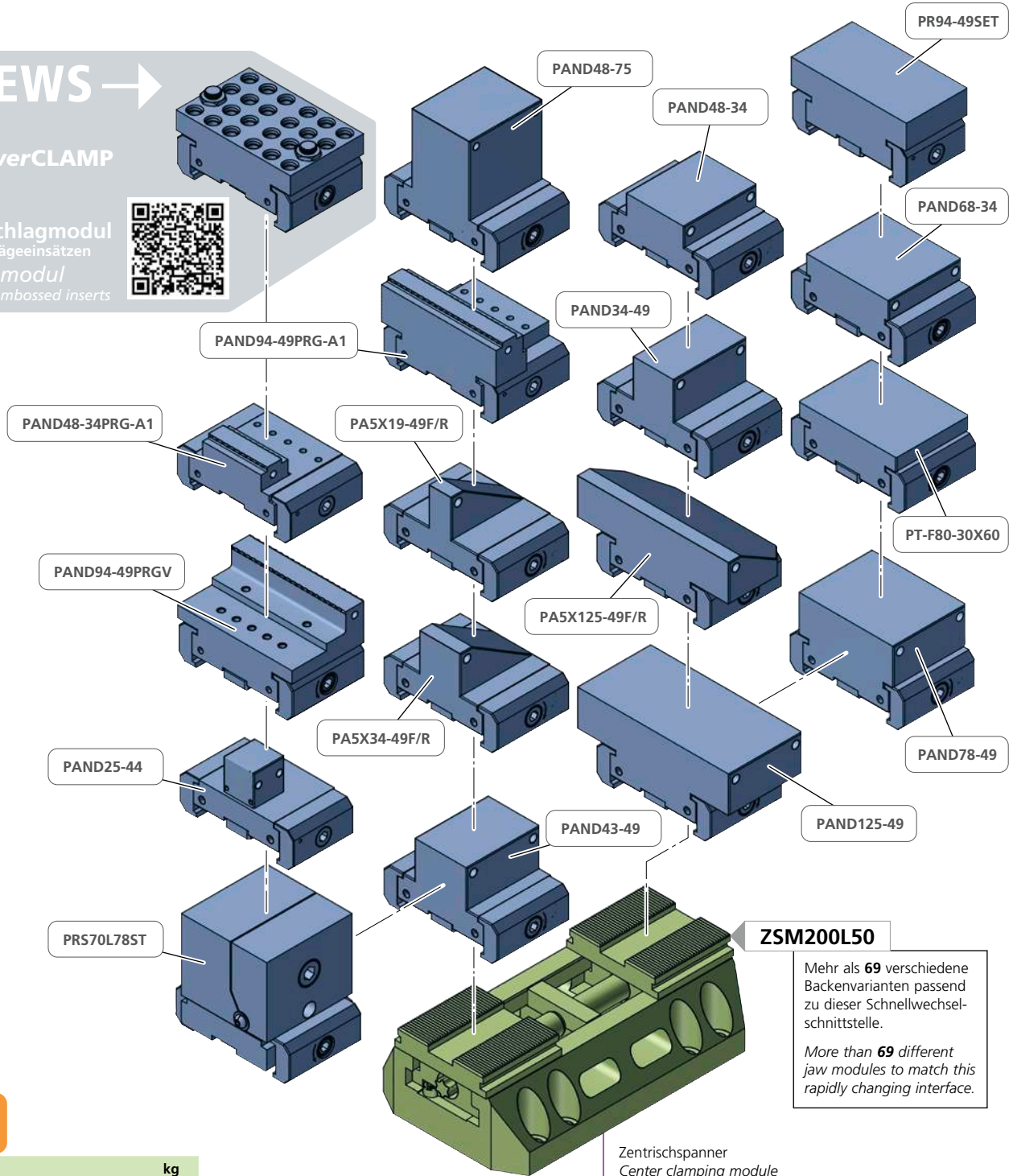

ZSM200L50

Mehr als 69 verschiedene Backenvarianten passend zu dieser Schnellwechelschnittstelle.

More than 69 different jaw modules to match this rapidly changing interface.

Zentrischspanner
Center clamping module



	kg
1 ZSM200L50	~5,6
ZSM180L50	~5,0
ZSM160L50	~4,5
ZSM140L50	~4,0
2x	

powerCLAMP p. 86 - 96

Bestellbeispiel / Ordering example: 1 x ZSM200L50 & 2 x PAND94-49PRG-A1

Zentrischspanner mit powerCLAMP Schnittstelle

Self centering vise with powerCLAMP interface

Art. Nr.	A	B	kg	L
ZSM140L50	60 – 120 mm	10 – 68 mm	~5,7	140
ZSM160L50	60 – 140 mm	10 – 88 mm	~6,4	160
ZSM180L50	60 – 160 mm	10 – 108 mm	~6,9	180
ZSM200L50	60 – 180 mm	10 – 128 mm	~7,4	200
ZSM300L50	60 – 280 mm	10 – 228 mm	~10,5	300

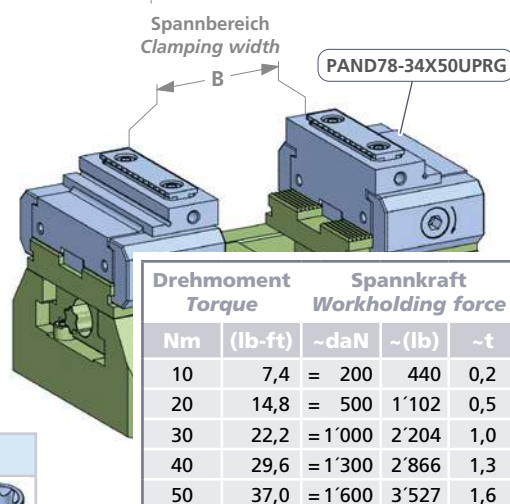
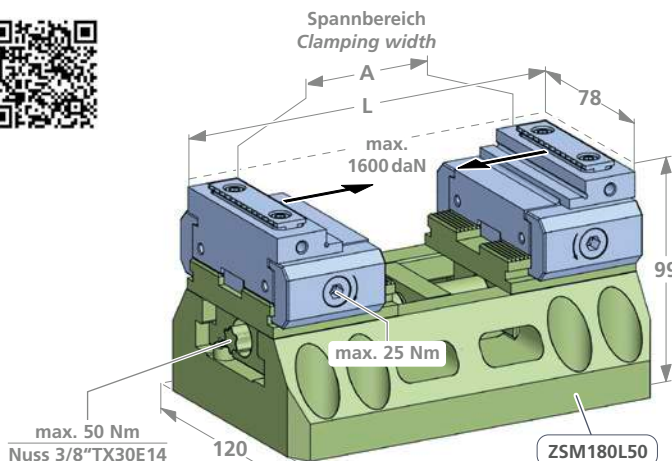
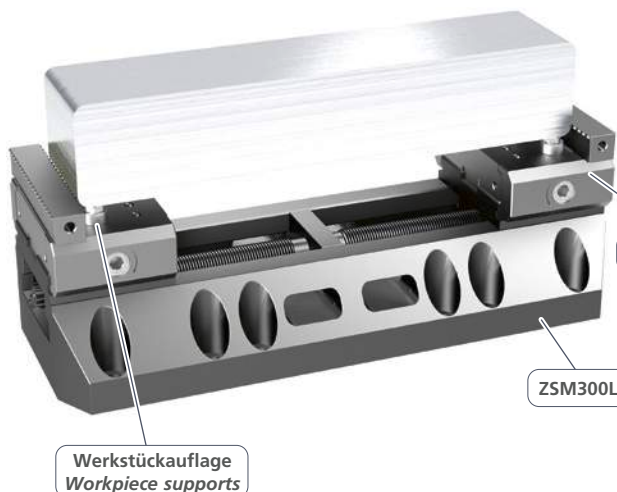

Mehr als 60 verschiedene Backenvarianten passend zu dieser Schnellwechselschnittstelle.
 More than 60 different jaw modules to match this rapidly changing interface.

NUSS3/8"TX30E14

WICHTIG!
 Bitte separat bestellen
IMPORTANT!
 Please order separately

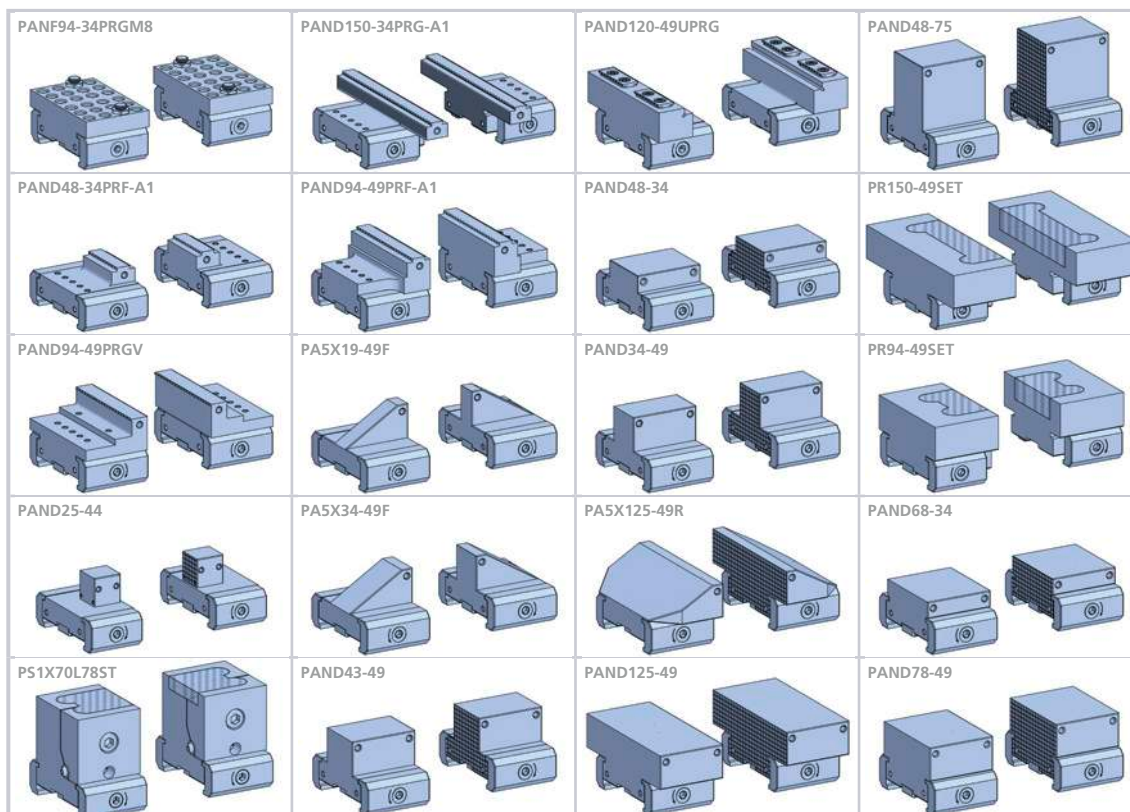

Seitlich verstellbarer Zentrischspannstock

Passend auf alle Power Clamp Basisschienen können mehrere dieser Zentrischspanner, seitlich aneinander gereiht, lange Werkstücke spannen und sind dabei flexibel in 2 mm Schritten seitlich verschiebbar.

Auch können diese für Mehrfachspannung genutzt werden und mehrere Einzelteile an fixen Punkten gespannt werden.

Einsatzgebiet für lange Profile, Stangen und Bleche aber auch Mehrfachspannung von fast allen Materialien.

Laterally adjustable centric vise

Fitting all Power Clamp basic rails, several of these self-centering vices can, arranged laterally in rows, clamp long work pieces and can hereby be flexibly shifted sideways in 2 mm steps.

They can also be used for multi clamping and several individual parts clamped at fixed points.

The field of application for long sections, rods and sheets but also multi clamping of almost all materials.

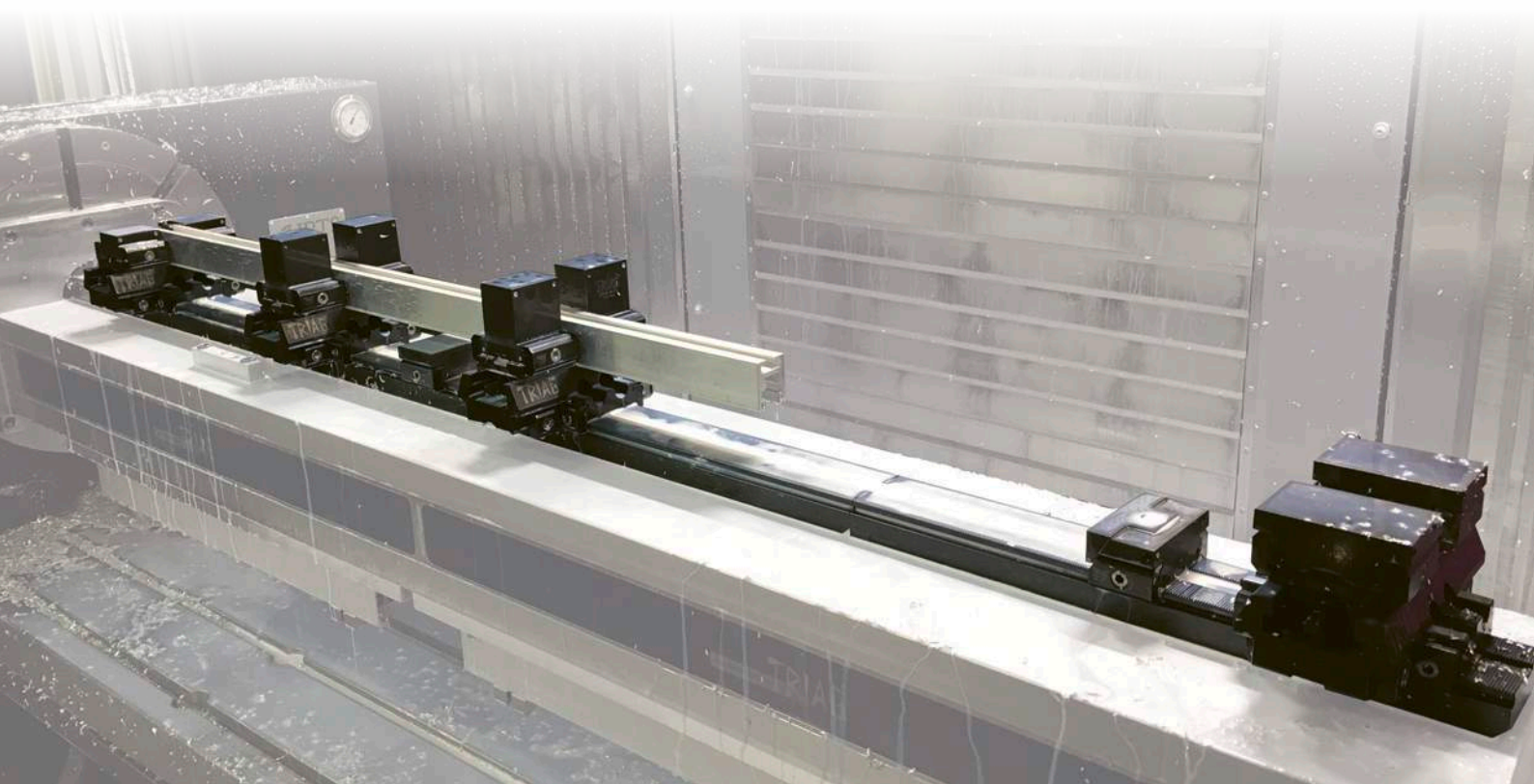
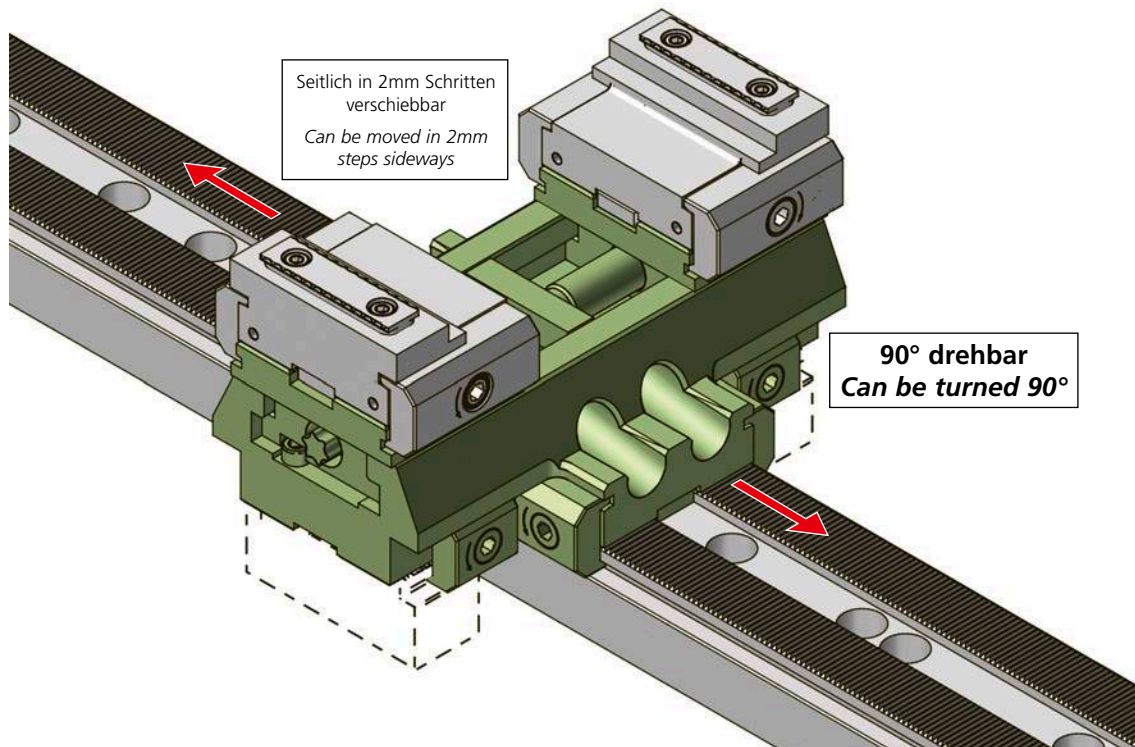

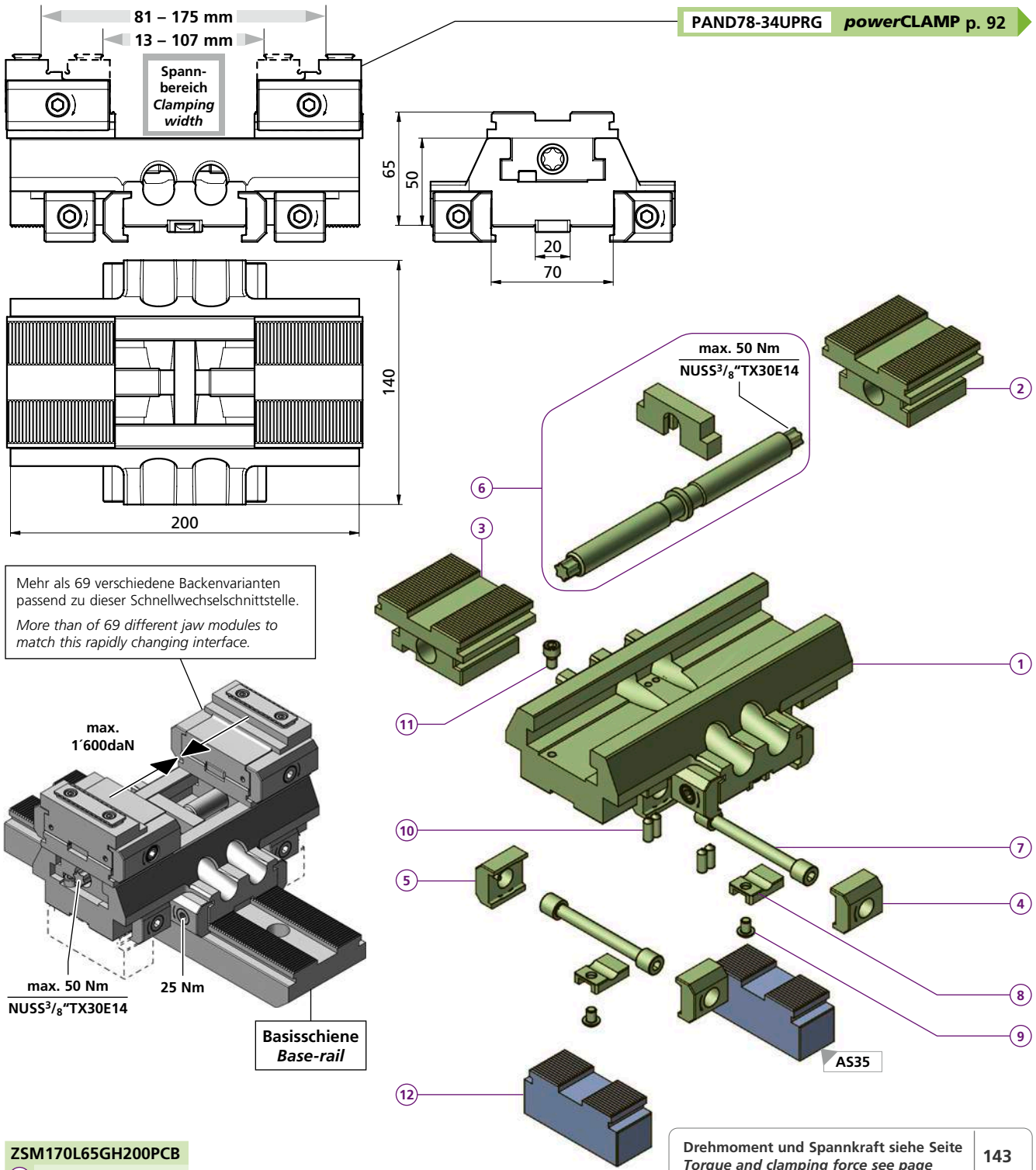

Mehr als 69 verschiedene Backenvarianten passend zu dieser Schnellwechselschnittstelle.
More than of 69 different jaw modules to match this rapidly changing interface.

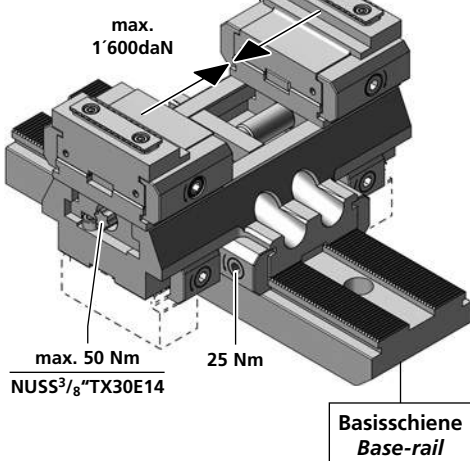

Drehmoment und Spannkraft siehe Seite 143
Torque and clamping force see page 143

- ZSM170L65GH200PCB**
- 1 1x TB140566
 - 2 1x TB150092
 - 3 1x TB150091
 - 4 4x PCSP30L
 - 5 4x PCSP30R
 - 6 1x PCS16TR200SET
 - 7 4x PCS14
 - 8 4x PCGU2030
 - 9 4x M6X8ISO7380
 - 10 4x M6X16DIN914
 - 11 1x M6X10ISO4762
 - 12 2x
- kg ~8,6

Schienehöhe / Rail height

AS35 (H = 35)	AS60 (H = 60)	AS80 (H = 80)

NUSS3/8\"TX30E14
WICHTIG!
Bitte separat bestellen
IMPORTANT!
Please order separately

Seitliche Stützen / Side support
Bei Gebrauch dieses Zentrischspanners, werden je nach Höhe der Basisschiene auf dessen sie aufgesetzt wird, zwei seitliche Stützen AS35 / AS60 / AS80 unterlegt.
When using this self centering vise, a side support AS35 / AS60 / AS80 is underlaid, depending on the height of the base rail on which it is placed.

Bestellbeispiel / Ordering example: 2 x ZSM170L65GH200PCB & 4 x AS35 & 1 x NUSS3/8\"TX30E14

Separat bestellen / Order separately

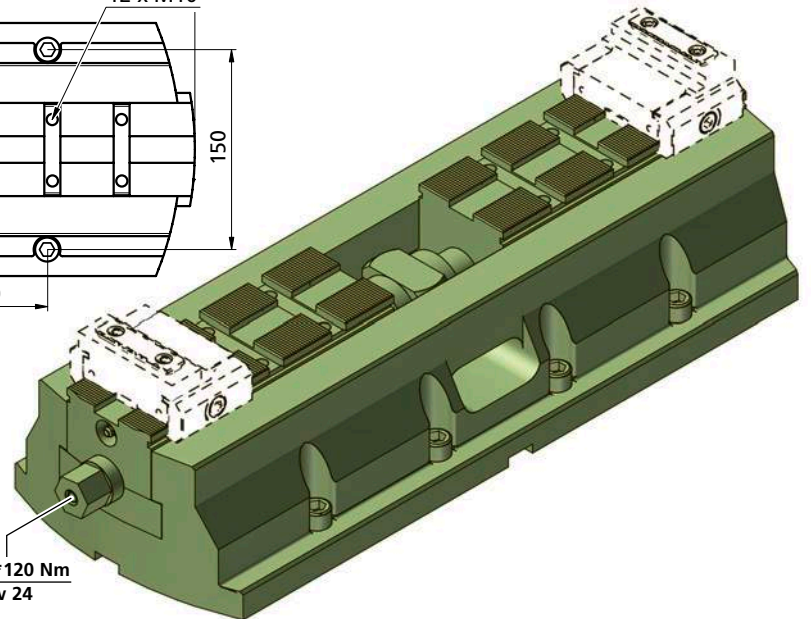
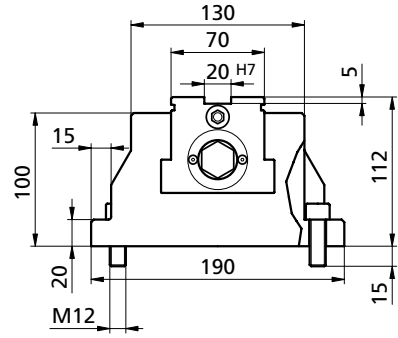
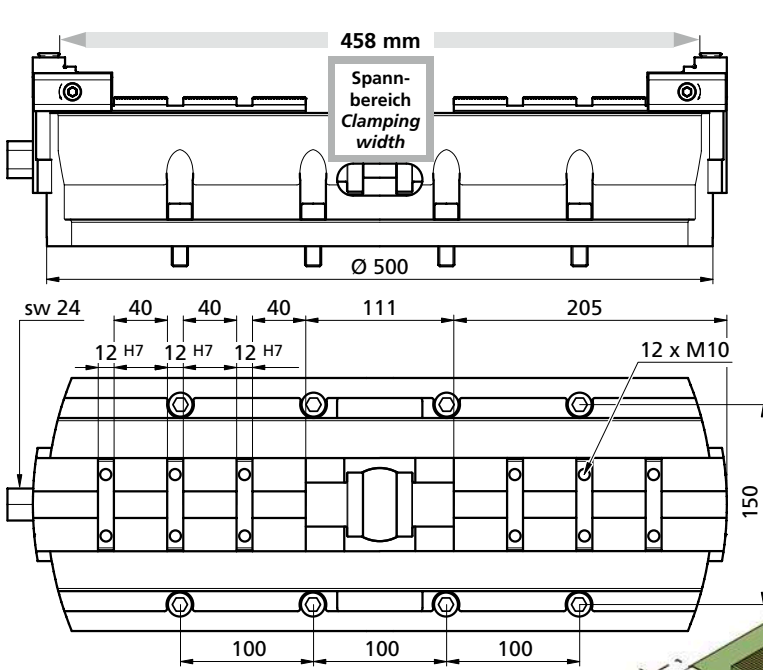

ZSMB500L112 kg = ~59
Backenhub (pro Backe)
Stroke of clamping (each jaw)
 55 mm

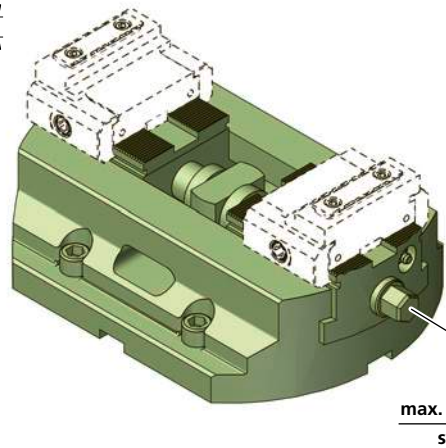
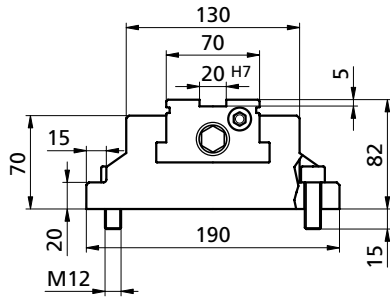
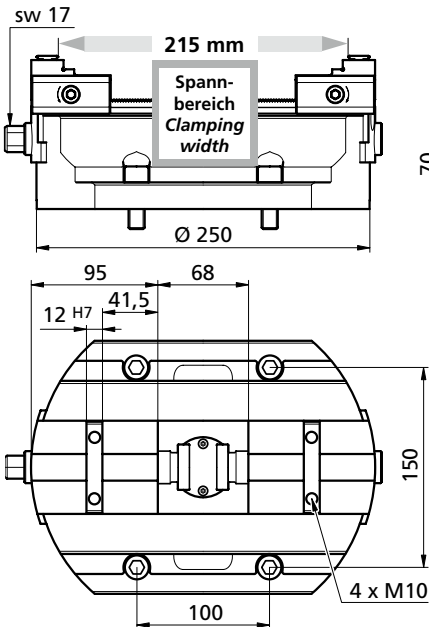

ZSMB250L82 kg = ~19
Backenhub (pro Backe)
Stroke of clamping (each jaw)
 35 mm

Drehmoment Torque		Spannkraft Workholding force			<p>Gut zu Wissen Good to know</p> <p>Diese Spannkraften werden für den Dauerbetrieb empfohlen! These clamping forces are recommended for continuous operation!</p> <p>Für kurzfristige Anwendung For short-term application</p>
Nm	(lb-ft)	~daN	~(lb)	~t	
40	29,5	= 800	1798	0,8	
60	44,26	= 1200	2697	1,2	
80	59	= 1600	3597	1,6	
100	73,75	= 2000	4496	2	
*120	88,5	= 2400	5395	2,4	

! Für längerfristige Anwendung ab 140 – 250 Nm müssen **geschraubte Backen** eingesetzt werden!
 For longer-term use from 140 – 250 Nm the **screwed jaws** must be used!

Bestellbeispiel / Ordering example : ZSMB500L112

Zentrischspanner mit Schnellwechselbacken

Self centering vise with quick-change jaws

Zentrischspanner mit Spannkrafterhaltung und Nachfederung
Self centering vise with spring loaded mechanism to maintain clamping force

Art. Nr.	www	A mm	B mm	C mm		kg
ZSQP300L50UPRG		80 – 260		8 – 188	$\pm 3^\circ$	~11,10
ZSQ200L50UPRG		80 – 160	44 – 124	8 – 88		~8,1
ZSQP200L50UPRG		80 – 160	44 – 124	8 – 88	$\pm 3^\circ$	~8,1
ZSQ180L50UPRG		80 – 140	44 – 104	8 – 68		~7,55
ZSQP180L50UPRG		80 – 140	44 – 104	8 – 68	$\pm 3^\circ$	~7,5
ZSQ160L50UPRG		80 – 120	44 – 84	8 – 48		~7,1
ZSQP160L50UPRG		80 – 120	44 – 84	8 – 48	$\pm 3^\circ$	~7,0

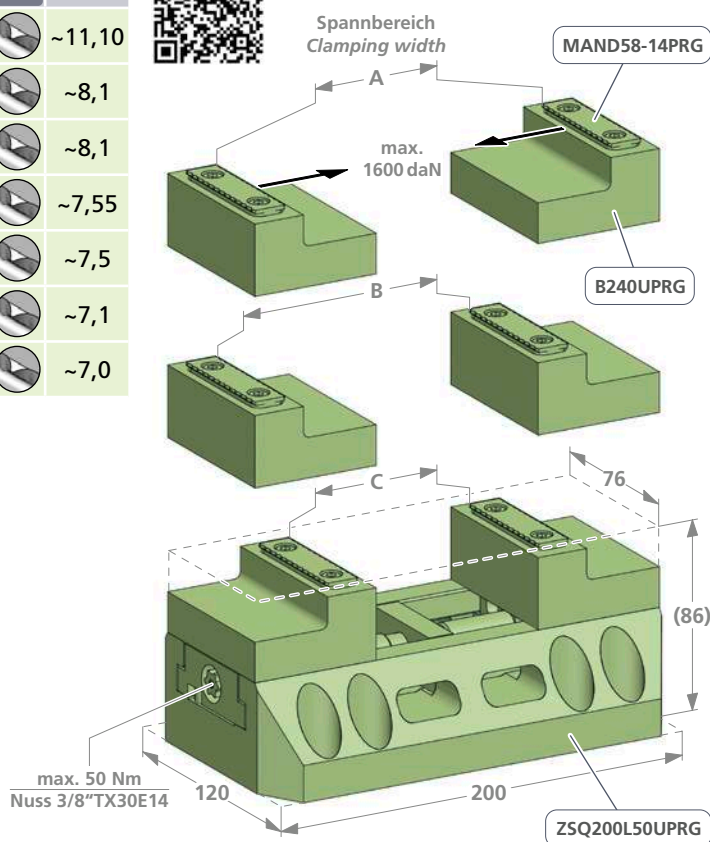

Für die Montage der Backen B240UPRG wird kein Werkzeug benötigt, diese werden per Hand auf dem Spanner eingeklinkt.

No tools are required for mounting the B240UPRG jaws, which are clipped onto the clamp by hand.

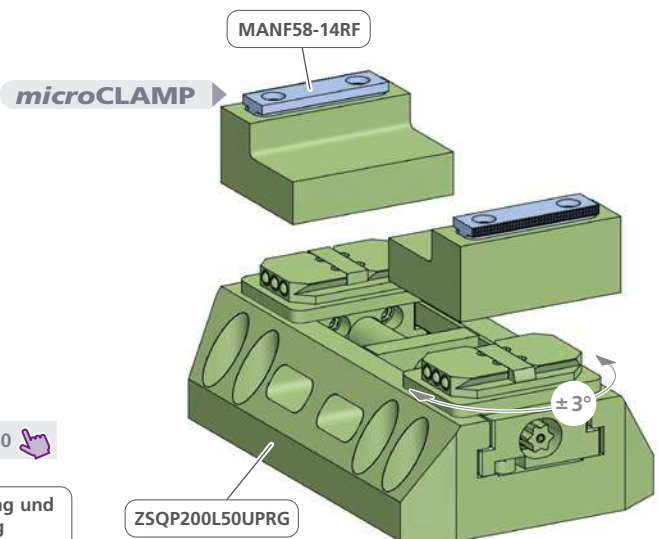

Drehmoment Torque		Spannkraft Workholding force		
Nm	(lb-ft)	~daN	~(lb)	~t
10	7,4	= 200	440	0,2
20	14,8	= 500	1'102	0,5
30	22,2	= 1'000	2'204	1,0
40	29,6	= 1'300	2'866	1,3
50	37,0	= 1'600	3'527	1,6

NUSS3/8"TX30E14

WICHTIG!
Bitte separat bestellen
IMPORTANT!
Please order separately



Zentrischspanner mit Schnellwechselbacken

Self centering vise with quick-change jaws

Typ **Q**

triCENTRO

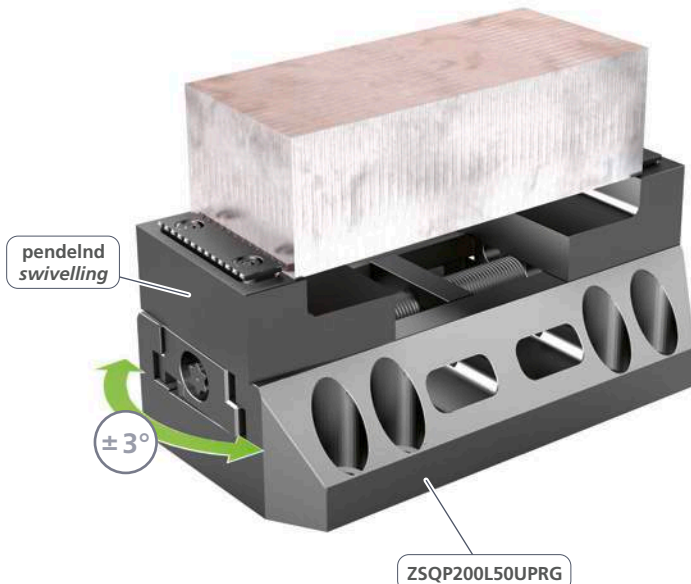

Mit diesen Zentrischspannern sind Ihre Werkstücke in festem Griff.
With these self centering vises your workpieces are in a firm grip.

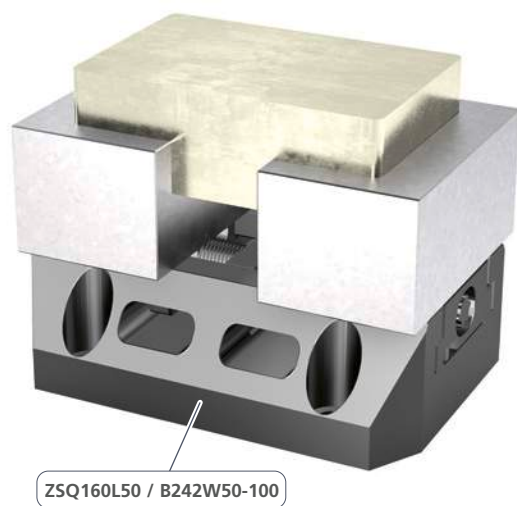

Spannbacke / Clamping jaw

Art. Nr.	B242W50-100	B240UPRG
i	Vergütungsstahl Tempering steel (1.7225)	57HRC
kg	~2	~0,52
QR		

Weich, zur Herstellung individueller Formbacken. / Soft, for the production of individual moulding jaw.

SCAN OR CLICK
 PDF
 STEP
 Formbacke Moulding jaw

SEPARAT BESTELLEN
ORDER SEPARATELY

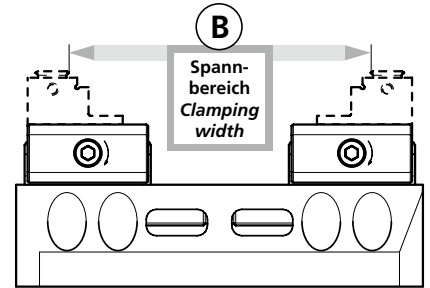
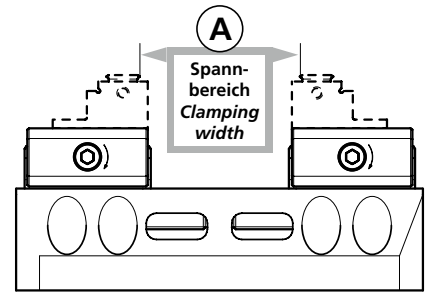
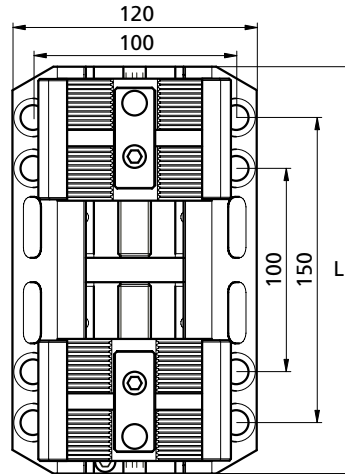
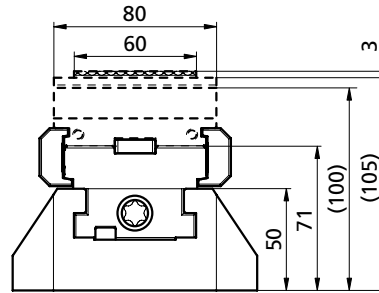
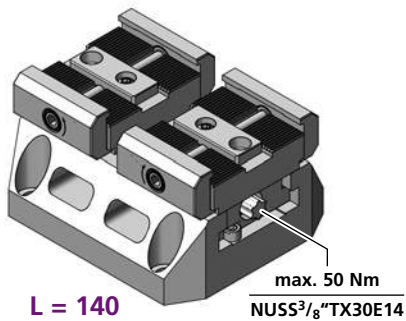
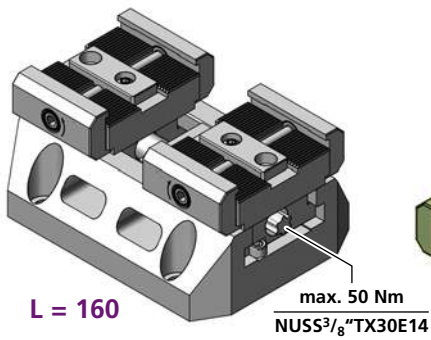
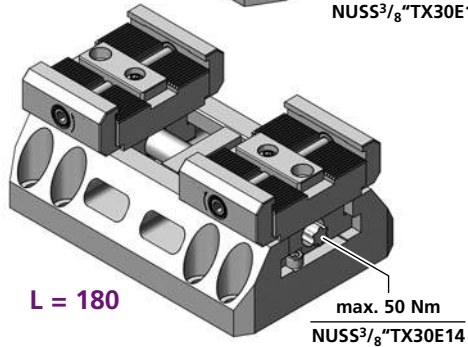
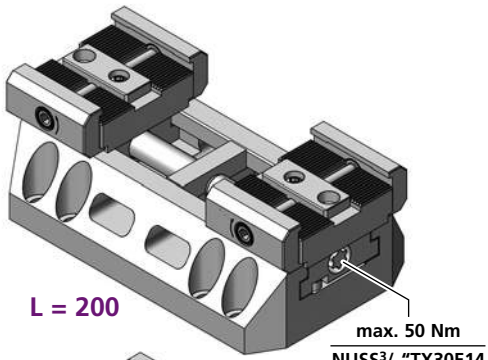

PCZB8050UPRG p. 152

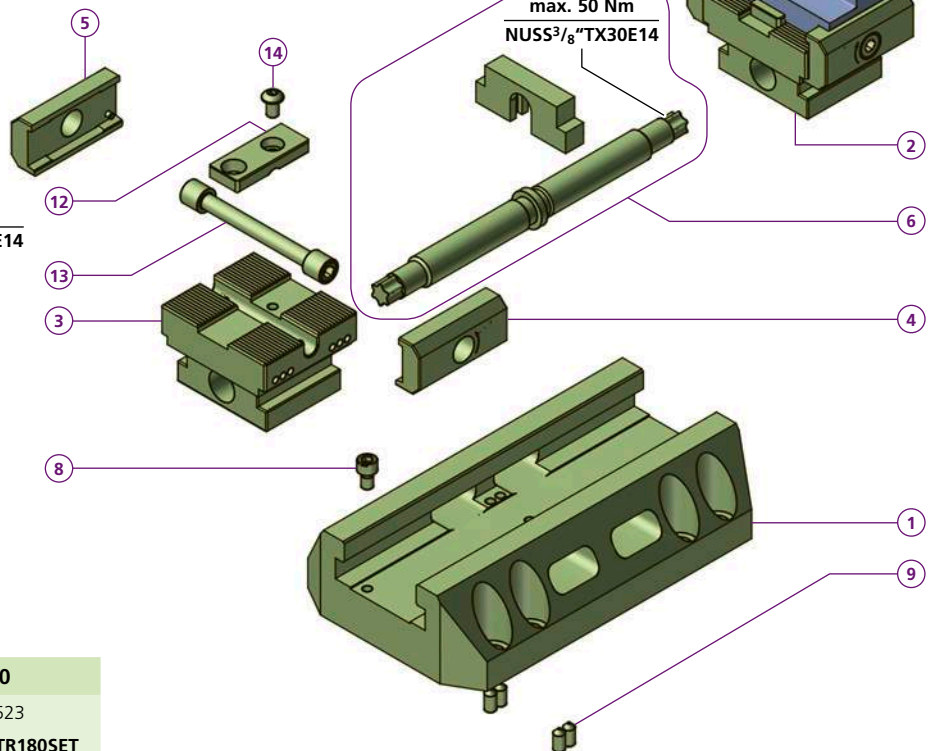

ZSB200L50

1	1x TK150025
2	1x ZB150791
3	1x ZB150792
4	2x PCSP60RG
5	2x PCSP60LG
6	1x PCS16TR200SET
8	1x M6X10ISO4762
9	4x M6X16DIN914
12	2x PCGU2049
13	2x PCS14
14	2x M6X8ISO7380
L	= 200
A	10 – 126 mm
B	58 – 174 mm
kg	~8,4

ZSB180L50

1	1x TK150523
6	1x PCS16TR180SET
L	= 180
A	10 – 104 mm
B	58 – 154 mm
kg	~7,9

ZSB160L50

1	1x TK150522
6	1x PCS16TR160SET
L	= 160
A	10 – 86 mm
B	58 – 134 mm
kg	~7,4

ZSB140L50

1	1x TK150521
6	1x PCS16TR140SET
L	= 140
A	10 – 65 mm
B	58 – 113 mm
kg	~6,7

Drehmoment und Spannkraft siehe Seite 151
Torque and clamping force see page 151

NUSS^{3/8}"TX30E14

WICHTIG!
Bitte separat bestellen
IMPORTANT!
Please order separately



Bestellbeispiel / Ordering example: 3 x ZSB200L50 & 6 x PCZB8050UPRG & 1 x NUSS^{3/8}"TX30E14

Drehmoment Torque		Spannkraft Workholding force			Gut zu Wissen Good to know
Nm	(lb-ft)	~daN	~(lb)	~t	
10	7,4	= 200	440	0,2	Diese Spannkraften werden für den Dauerbetrieb empfohlen! <i>These clamping forces are recommended for continuous operation!</i>
20	14,8	= 500	1'102	0,5	
30	22,2	= 1'000	2'204	1,0	
40	29,6	= 1'300	2'866	1,3	
50	37,0	= 1'600	3'527	1,6	
60	44,4	= 1'800	3'968	1,8	Für kurzfristige Anwendung <i>For short-term application</i>
70	51,8	= 2'100	4'629	2,1	

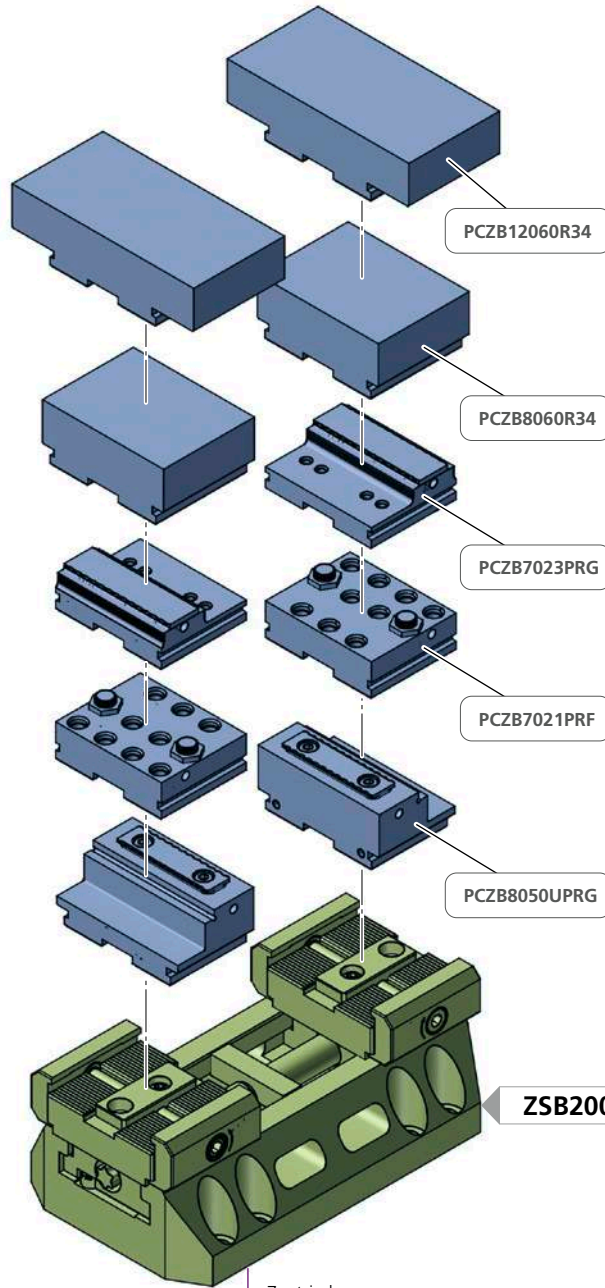
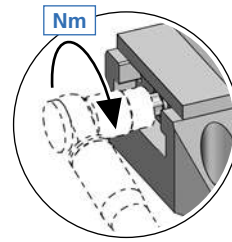

PCZB12060R34

PCZB8060R34

PCZB7023PRG

PCZB7021PRF

PCZB8050UPRG

ZSB200L50

Zentrischspanner
Center clamping module

Mehr als 8 verschiedene Backenvarianten passend zu dieser Schnellwechsellchnittstelle.
More than 8 different jaw modules to match this rapidly changing interface.

B

	kg
1 ZSB200L50	~8,4
ZSB180L50	~7,9
ZSB160L50	~7,4
ZSB140L50	~6,7
2x	

p. 152

Bestellbeispiel / Ordering example: 1 x ZSM200L50 & 2 x PCZB8050UPRG

Separat bestellen / Order separately

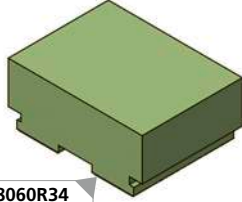
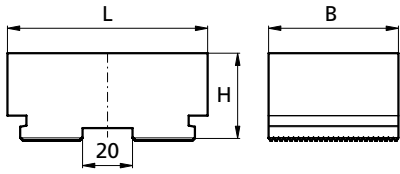

PCZB8060R34

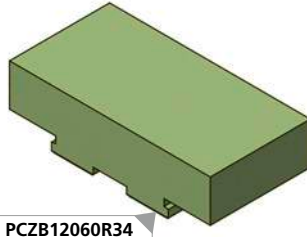

PCZB12060R34

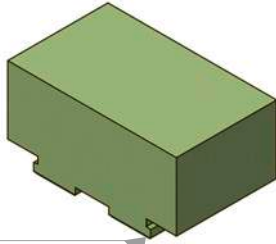

PCZB10060R50ST

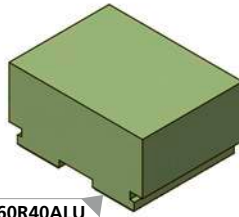

PCZB8060R40ALU

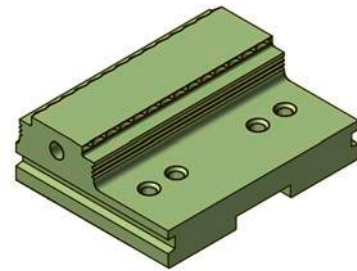
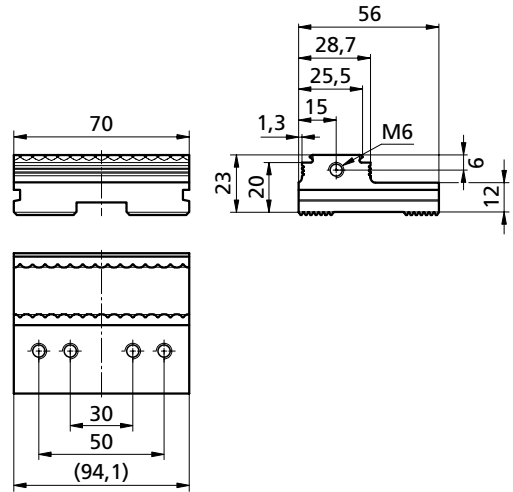

PCZB7023PRG kg ~0,54

		L	B	H	kg
PCZB8060R34	(Stahl/Steel)	80	60	34	~1,2
PCZB12060R34	(Stahl/Steel)	120	60	34	~1,7
PCZB10060R50ST	(Stahl/Steel)	101	60	50	~2,2
PCZB8060R40ALU	ALU	80	60	40	~0,52
PCZB10060R50	ALU	101	60	50	~0,76

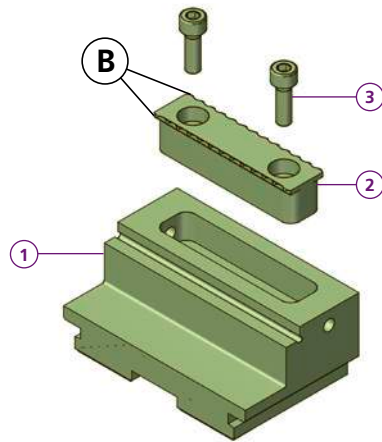

PCZB8050UPRG

- 1 1x TB161200
 - 2 1x MAND58-14PRG
 - 3 1x M5X16ISO4762
- kg ~0,75

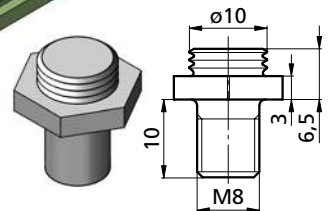
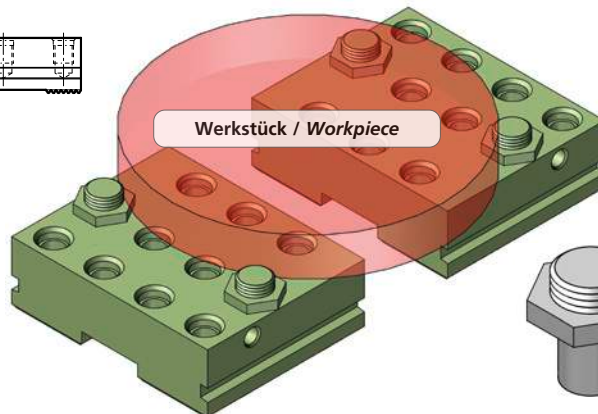
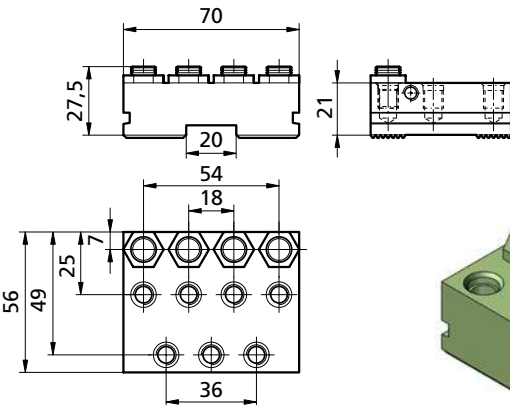
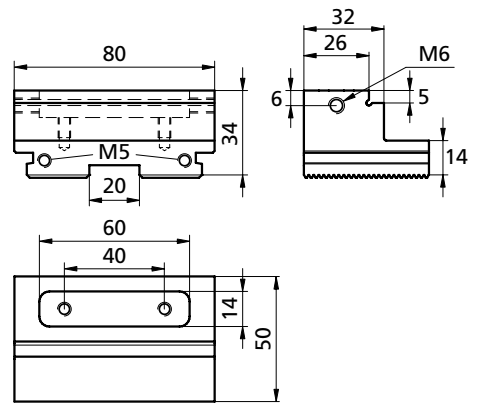

PCZB7021PRF kg ~0,6

PRG1003M8

Bestellbeispiel / Ordering example: 2 x PCZB7021PRF & 4 x PRG1003M8

spaceGRIP III

Spannbereich bis 180 mm, Spannkraft bei 70 Nm, 2,1 t/2100 daN. Hier kommen die «Grossen» unserer Zentrischspanner zum Einsatz. Speziell ist der Aufbau auf einer Stahl-Mineralgusspyramide um beste Verhältnisse bezüglich Vibrationsdämpfung zu bieten. Die Zentrischspanner dazu gibt es in vier Gehäuselängen (140, 160, 180 und 200 mm) und bis zu 60 Backenvarianten.

spaceGRIP III

Spans of up to 180 mm, clamping force at 70 Nm, 2.1 t/2100 daN. Here the «big ones» of our self-centering vices go into action. And there is the special setup of a steel mineral casting pyramid to provide the best conditions for vibration dampening. The self-centering vice for this is available with four housing lengths (140, 160, 180 and 200 mm) and up to 60 jaw versions.

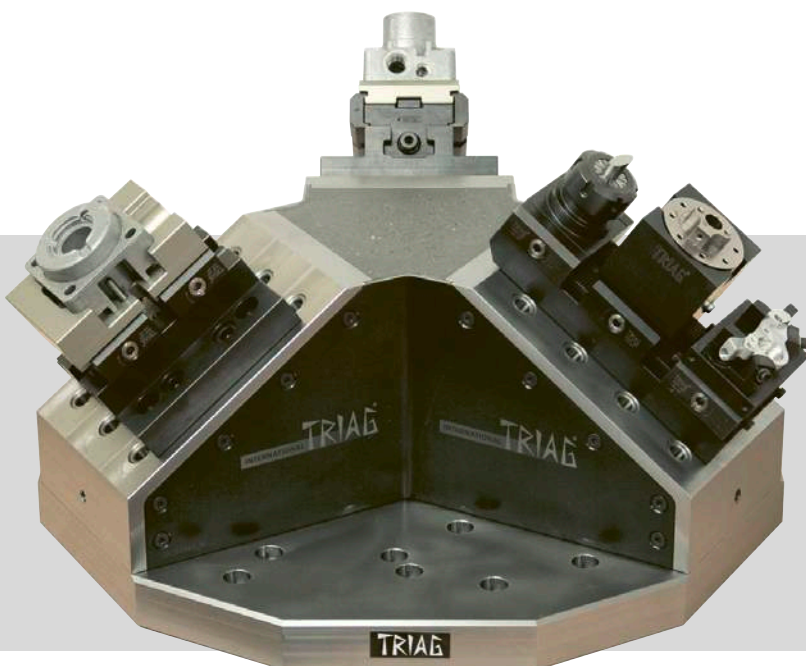

SPACEGRIP III

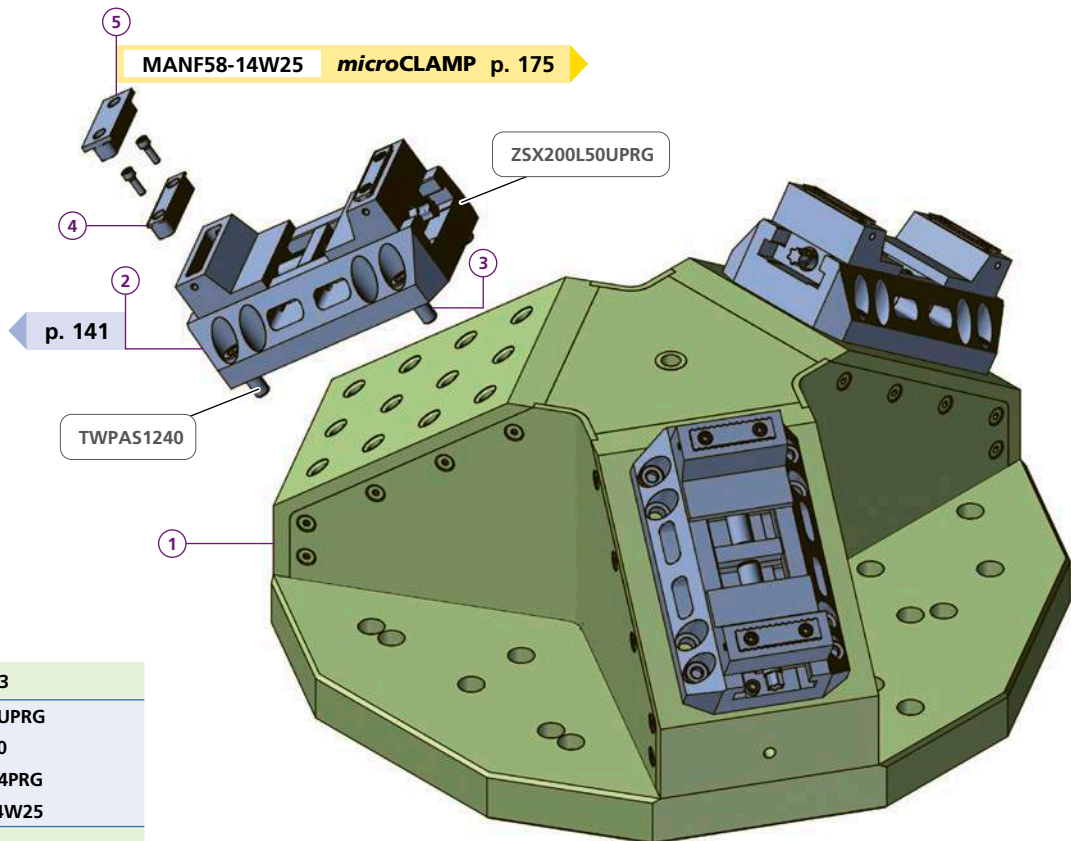
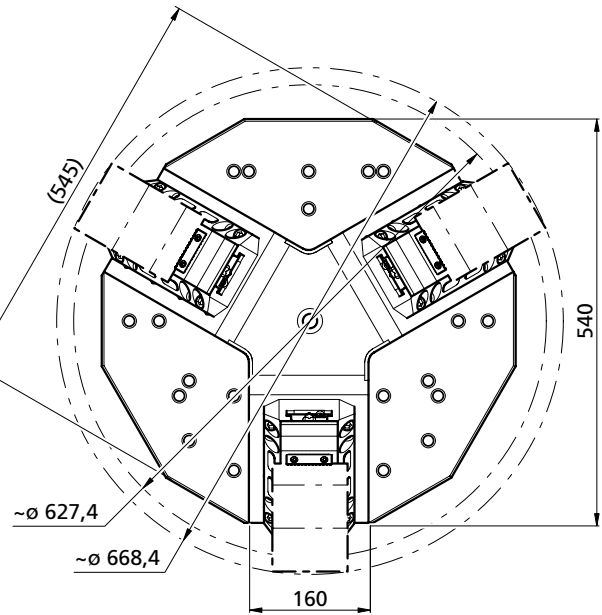
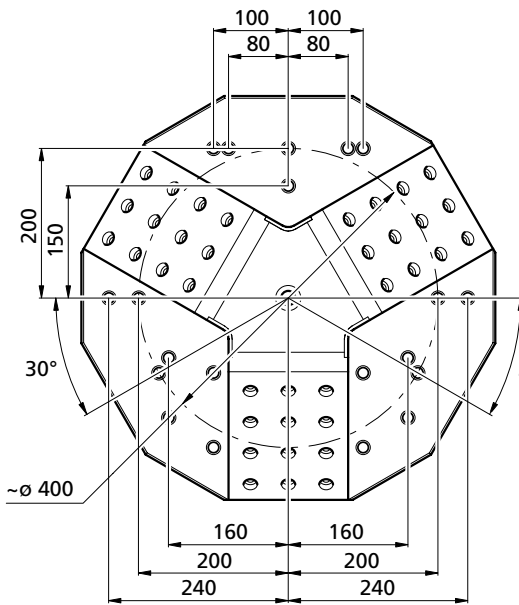
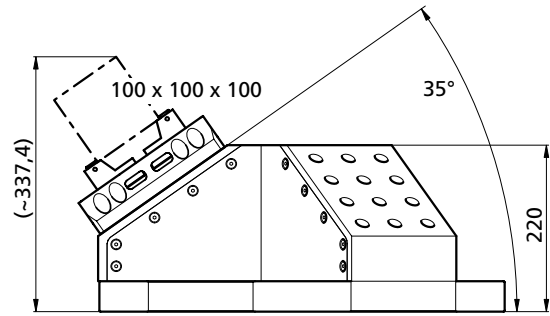
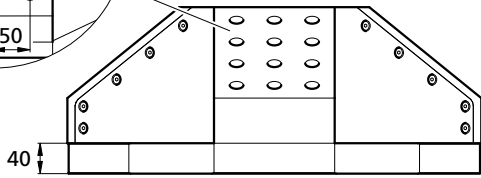
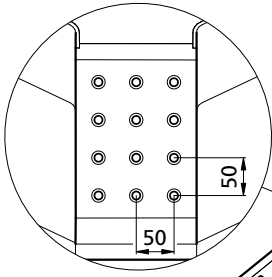

1	1x	5AXZSX35-3
2	3x	ZSX200L50UPRG
3	12x	TWPAS1240
4	6x	MANF58-14PRG
5	6x	MANF58-14W25
kg		~135

Bestellbeispiel / Ordering example: 1 x 5AXZSX35-3 & 3 x ZSX200L50UPRG & 6 x MANF58-14W25

Separat bestellen / Order separately

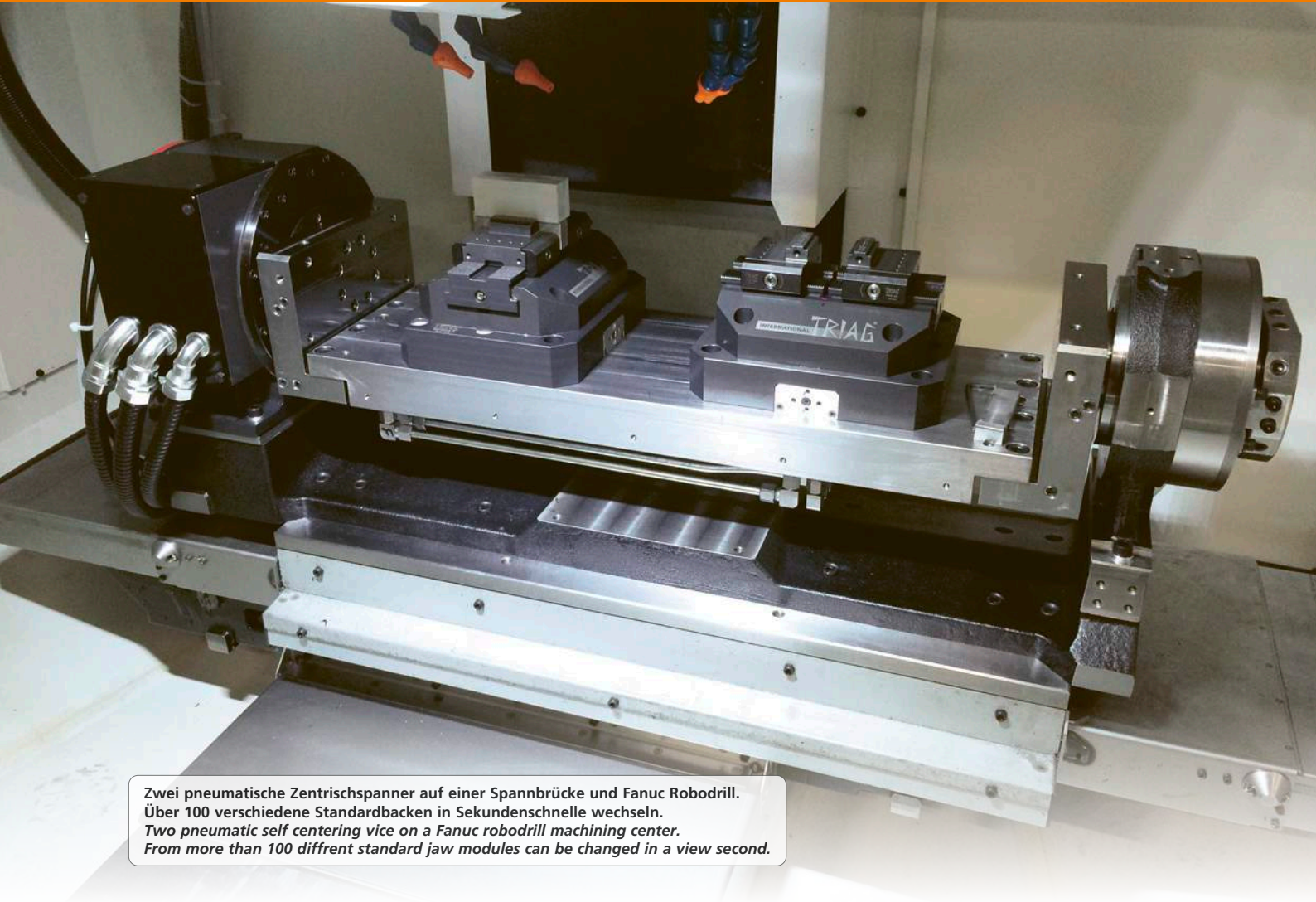

Zwei pneumatische Zentrischspanner auf einer Spannbrücke und Fanuc Robodrill.
Über 100 verschiedene Standardbacken in Sekundenschnelle wechseln.
Two pneumatic self centering vise on a Fanuc robodrill machining center.
From more than 100 different standard jaw modules can be changed in a view second.

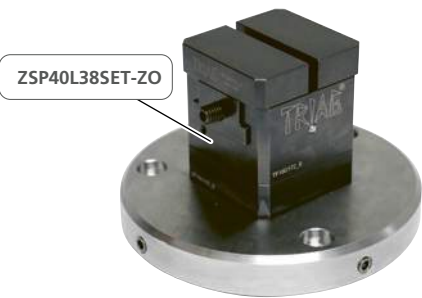

ZSP40L38SET-ZO



ZSP125L85-1

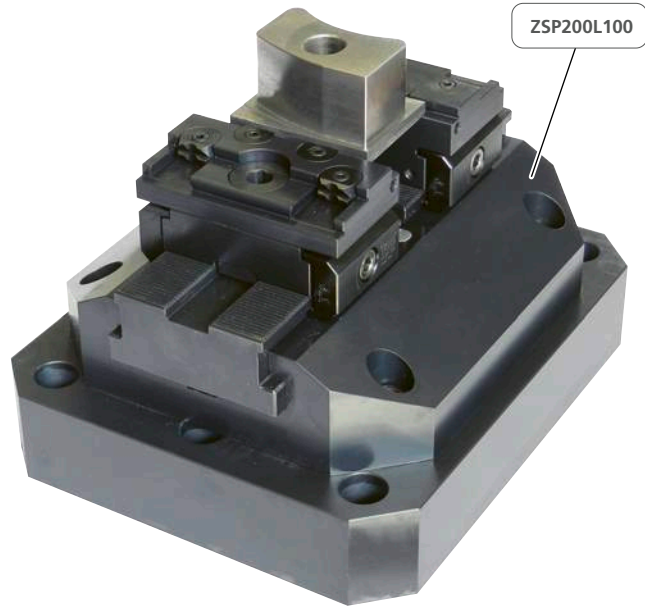

ZSP200L100

ZSP Micro Pneumatischer Zentrischspanner

Pneumatic self centering vise

SET18ZSP40L38-2 ZSP40L38-2

triCENTRO

0,6 – 3,6 mm Hub

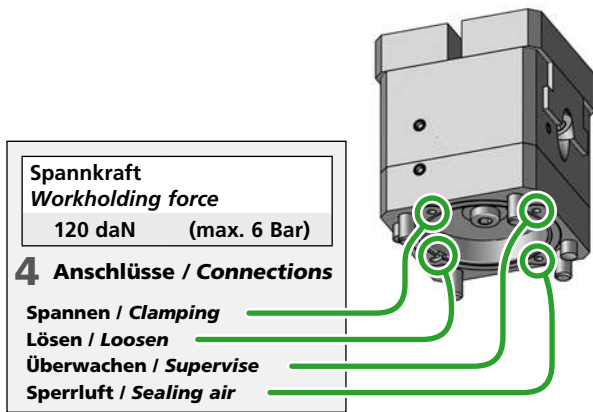
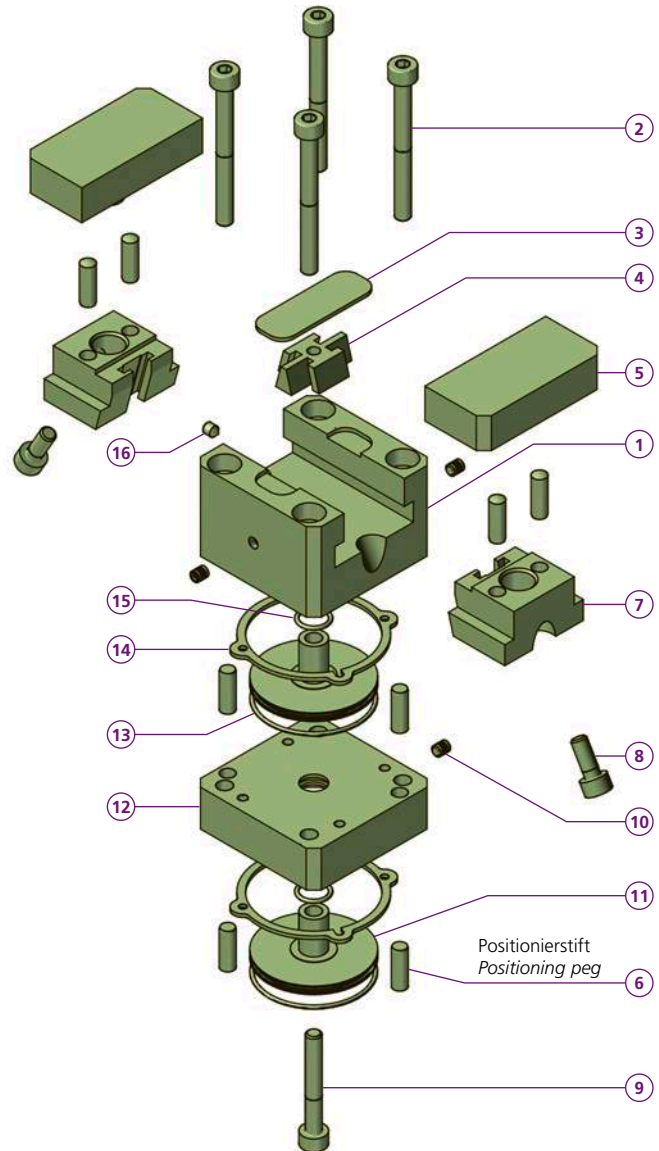
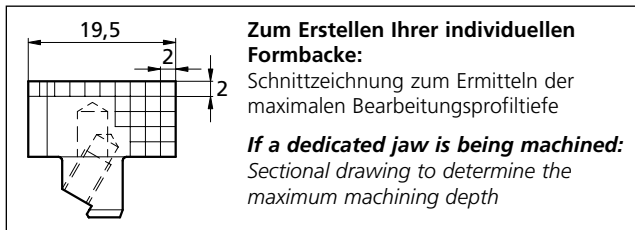
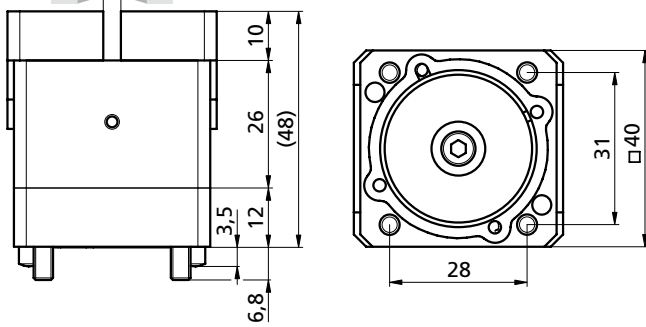

Spannkraft
Workholding force
120 daN (max. 6 Bar)

4 Anschlüsse / Connections

Spannen / Clamping
Lösen / Loosen
Überwachen / Supervise
Sperrluft / Sealing air

SET18ZSP40L38-2

- 1 1x TF180166
- 2 4x TN100865
- 3 1x TF180169
- 4 1x TF180168
- 5 2x B222
- 6 8x TN100428
- 7 2x TF180167
- 8 2x TN100321
- 9 1x TB180316
- 10 3x TN100824
- 11 2x TF180170
- 12 1x TF180171
- 13 2x TN100819
- 14 2x TB180306
- 15 2x TN100818
- 16 1x TN10091

kg ~0,52

Luftvolumen / Air volume	
Spannen / Clamping	Lösen / Loosen
8,2cm ³	8,4cm ³

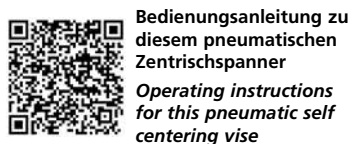

Bedienungsanleitung zu diesem pneumatischen Zentrischspanner
Operating instructions for this pneumatic self centering vise

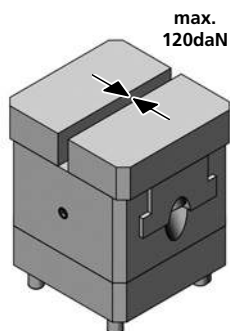

weich soft 1.7225

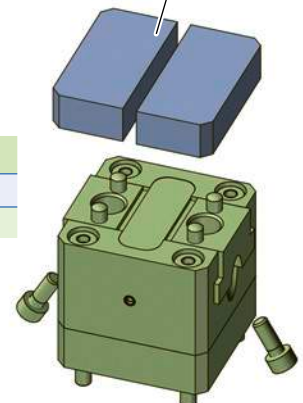

ZSP40L38-2

5 2x B222
kg ~5,2

Bestellbeispiel / Ordering example: SET18ZSP40L38-2

Separat bestellen / Order separately

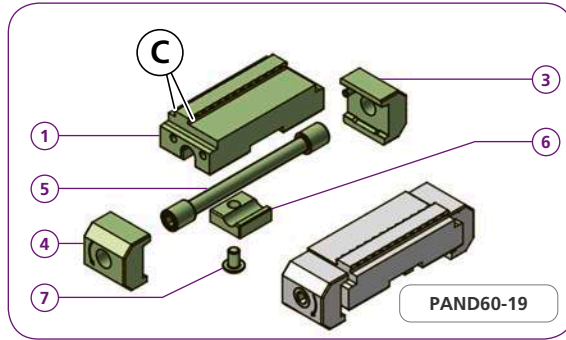
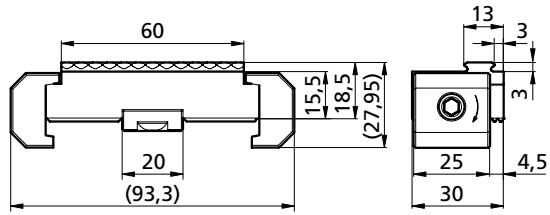
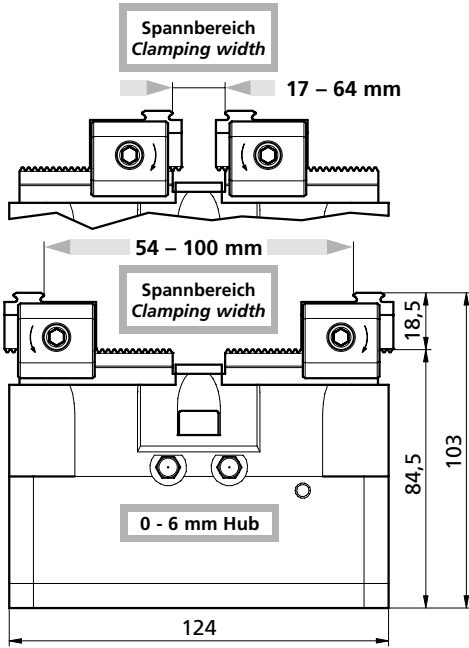

ZSP125L85-1

- 1 1x TB180474
 - 2 2x TB180476
 - 3 2x M8X16ISO4762
 - 4 2x M3X6DIN7991
 - 5 1x TB171140
 - 6 1x TB171141
 - 7 1x TB180477
 - 8 2x TN100014
 - 9 2x TB170530
 - 10 2x TN100021
 - 11 3x TN100009
 - 12 1x TK160467
 - 13 1x TN100012
 - 14 1x TK160075
 - 15 1x M6X35ISO4762
 - 16 1x TN100020
 - 17 1x TB180475
 - 18 2x TN100015
 - 19 4x TN100013
 - 20 1x TN100027
 - 21 1x TB180268
 - 22 4x PCPF16L6
 - 23 1x M5X6DIN913
 - 24 1x TB180478
- kg ~7,4

PAND60-19

- 1 1x TB171149
 - 3 1x PCSP25L
 - 4 1x PCSP25R
 - 5 1x PCS10
 - 6 1x PCGU2019
 - 7 1x M5X8ISO7380
- kg ~0,4

Luftvolumen / Air volume	
Spannen / Clamping	Lösen / Loosen
80,1 cm ³	80,8 cm ³



Bedienungsanleitung zu diesem pneumatischen Zentrischspanner
Operating instructions for this pneumatic self centering vise

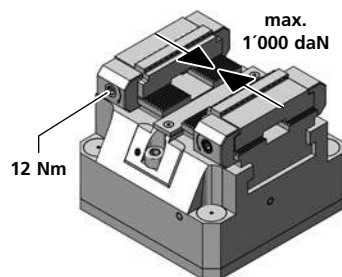

SET18ZSP125L85-1

- 1x ZSP125L85-1
 - 2x PAND60-19
- kg ~8,2

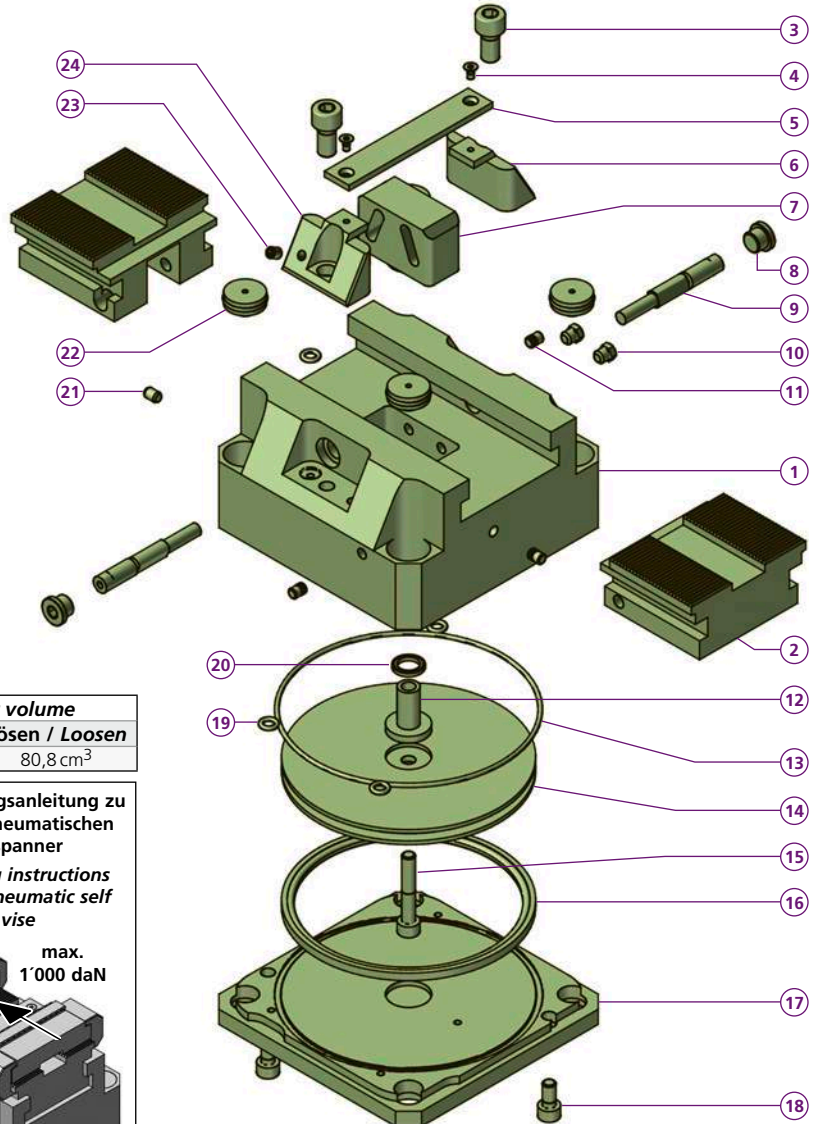

	Druck Pressure		Spannkraft Clamping force		
	Bar		~daN	~(lb)	~t
Einfacher Kolben Single piston	8	=	600	1'320	0,6
	10	=	800	1'760	0,8
	12	=	1'000	2'650	1,0

Bestellbeispiel / Ordering example: SET18ZSP125L85-1

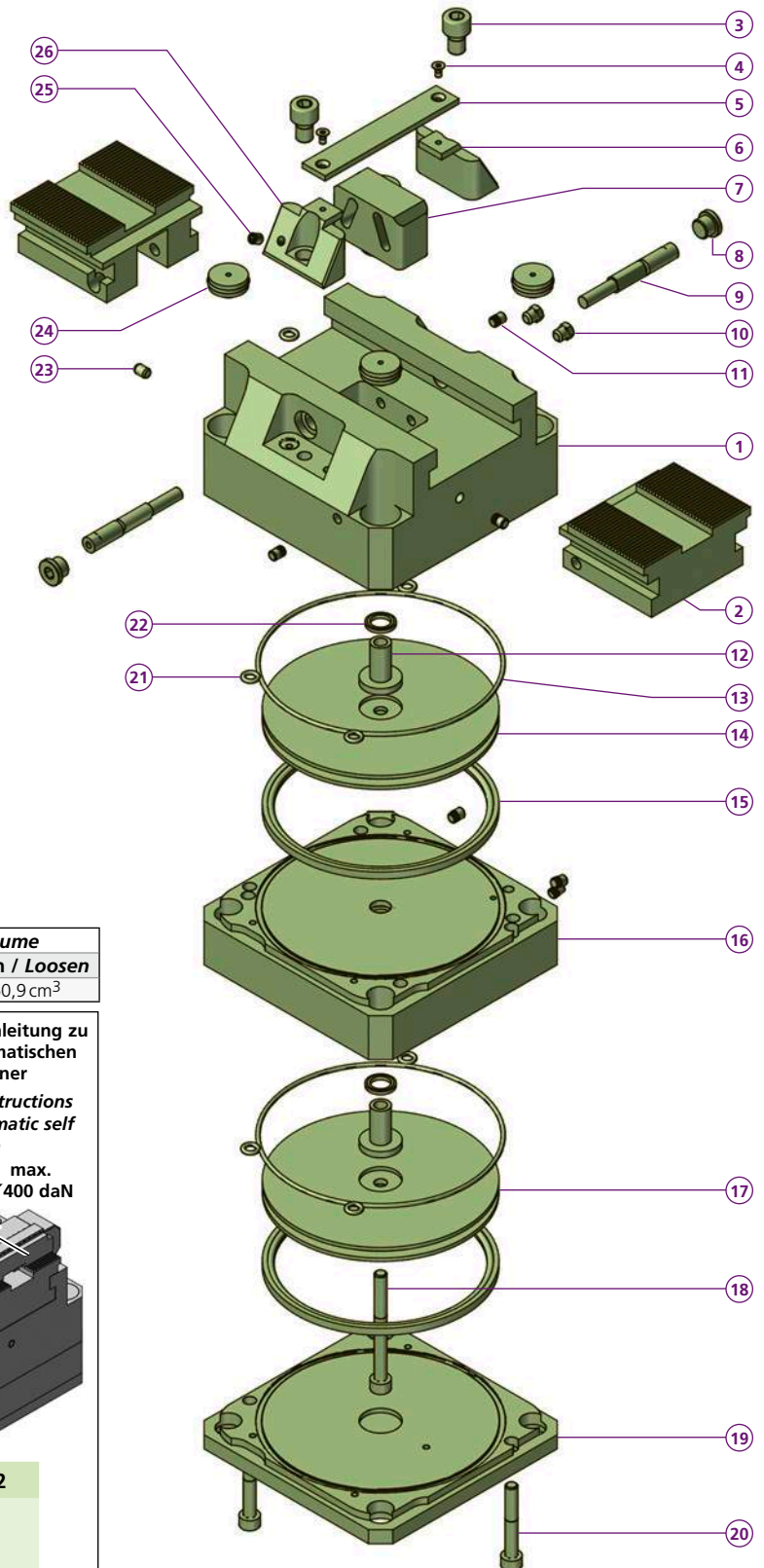
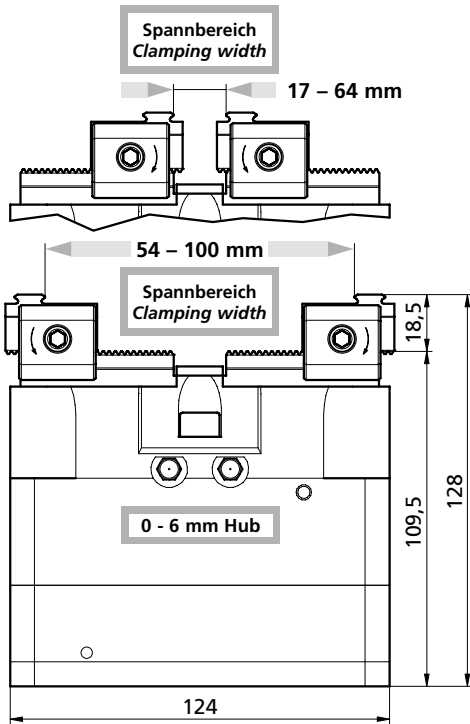

ZSP125L110-2

- 1 1x TB180474
 - 2 2x TB180476
 - 3 2x **M8X16ISO4762**
 - 4 2x M3X6DIN7991
 - 5 1x TB171140
 - 6 1x TB171141
 - 7 1x TB180477
 - 8 2x TN100014
 - 9 2x TB170530
 - 10 2x TN100021
 - 11 6x TN100009
 - 12 2x TK160467
 - 13 2x TN100012
 - 14 1x TB170147
 - 15 2x TN100020
 - 16 1x TB180480
 - 17 1x TK160075
 - 18 1x **M6X60ISO4762**
 - 19 1x TB180475
 - 20 2x **M6X40ISO4762**
 - 21 7x TN100013
 - 22 2x TN100027
 - 23 1x TB180268
 - 24 4x PCPF16L6
 - 25 1x M5X16DIN913
 - 26 1x TB180478
- kg ~9,4

Luftvolumen / Air volume	
Spannen / Clamping	Lösen / Loosen
160,2 cm ³	160,9 cm ³

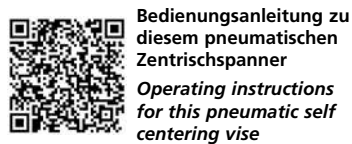

Bedienungsanleitung zu diesem pneumatischen Zentrischspanner
Operating instructions for this pneumatic self centering vise

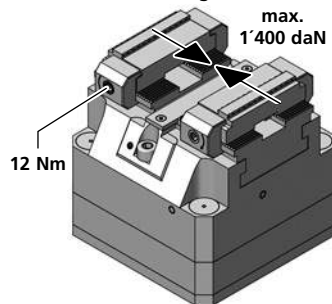

SET18ZSP125L110-2

- 1x ZSP125L110-2
 - 2x PAND60-19
- kg ~11,3

PAND60-19

- 1 1x TB171149
 - 3 1x PCSP25L
 - 4 1x PCSP25R
 - 5 1x PCS10
 - 6 1x PCGU2019
 - 7 1x **M5X8ISO7380**
- kg ~0,4

Masszeichnung & Isometrische Darstellung:

Siehe Seite | See page **p. 159**

Dimensional drawing & Isometric representation:

Druck Pressure	Spannkraft Clamping force		
	Bar	~daN	~(lb) ~t
Doppelkolben Double piston	8	= 1'000	2'200 1,0
	10	= 1'400	3'090 1,4

Bestellbeispiel / Ordering example : **SET18ZSP125L110-2**

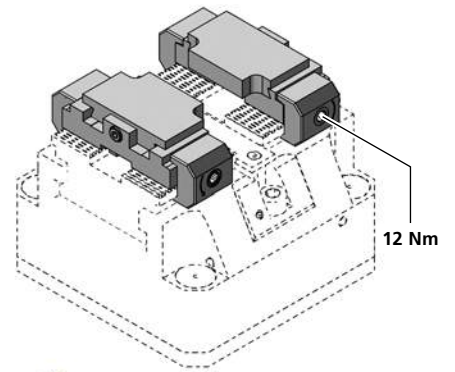
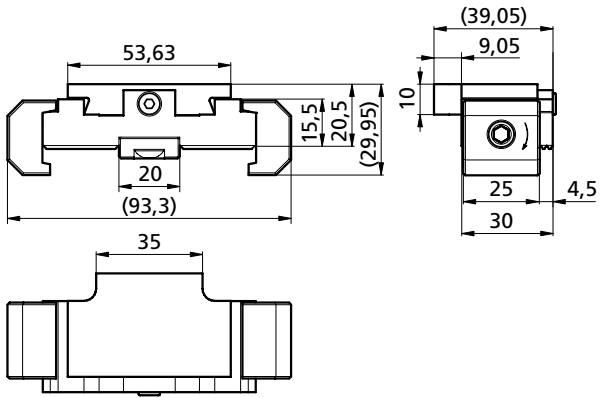

PAND60-20.5UWB

1	1x TK171294
2	1x TK180360
3	1x PCSP25L
4	1x PCSP25R
5	1x PCS10
6	1x PCGU2019
7	1x M5X8ISO7380
8	1x M4X8ISO4762
kg	~0,3

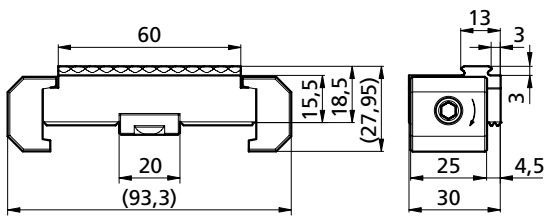
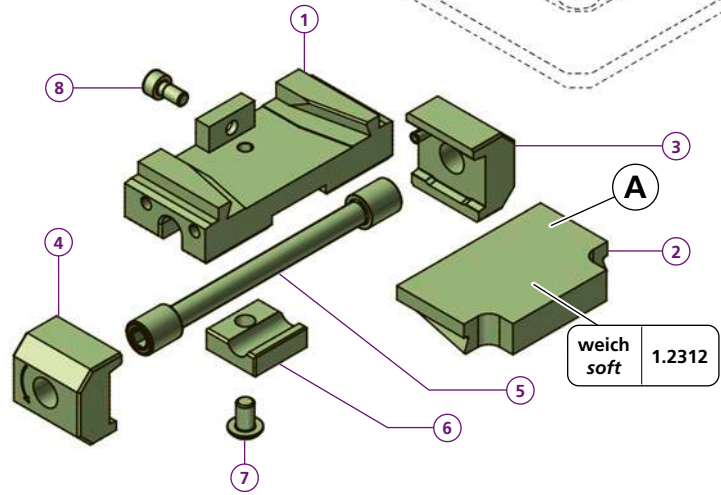

PAND60-20.5UWB

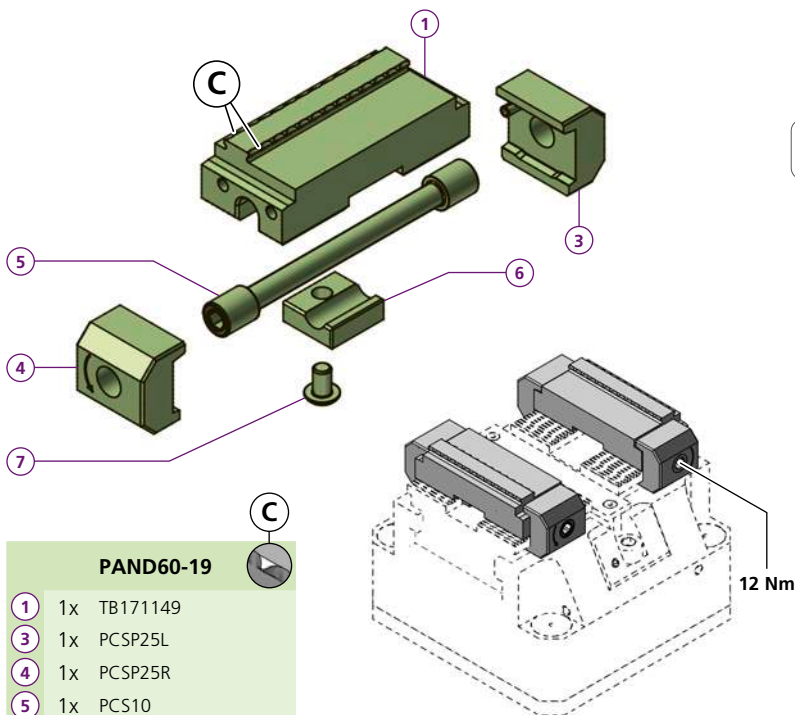

PAND60-19

1	1x TB171149
3	1x PCSP25L
4	1x PCSP25R
5	1x PCS10
6	1x PCGU2019
7	1x M5X8ISO7380
kg	~0,4

PAND60-19

ZSP125L85-1

Bestellbeispiel / Ordering example: PAND60-20.5UWB

ZSP Grande

Pneumatischer Zentrischspanner

Pneumatic self centering vise

ZSP150L100

ZSP200L100

ZSP250L100

triCENTRO

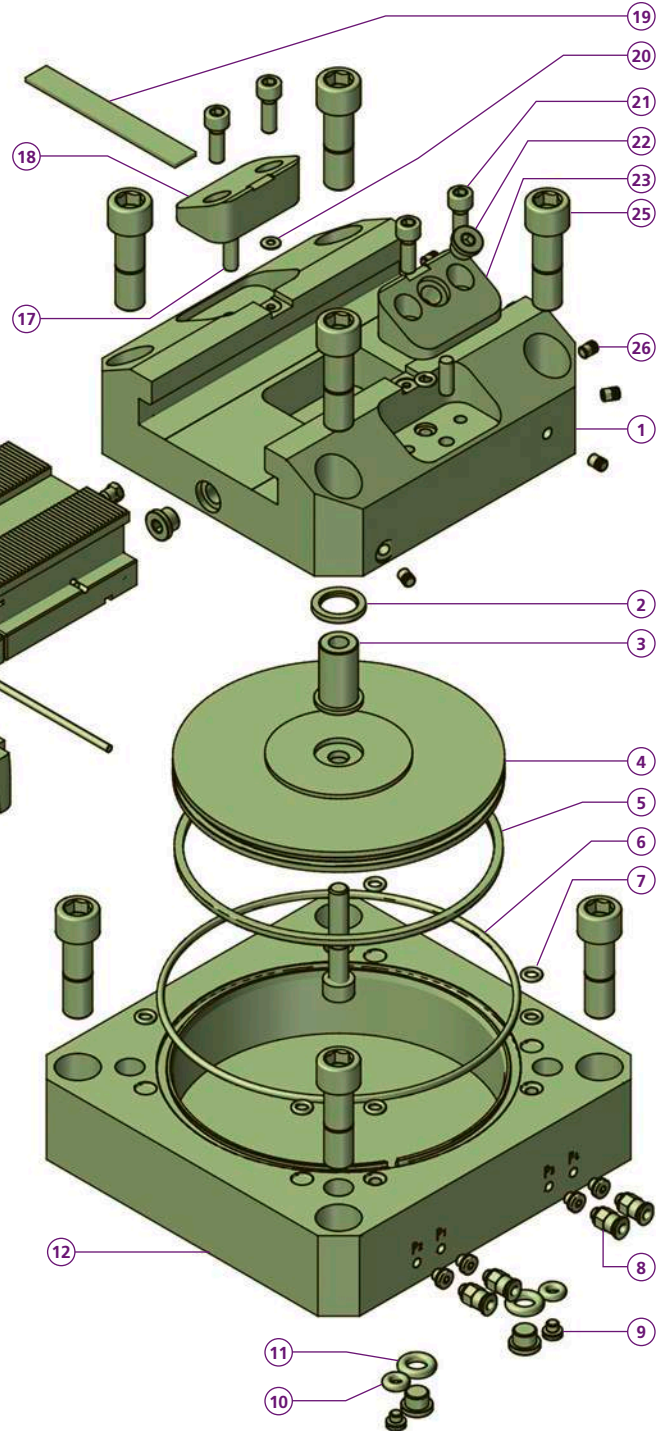
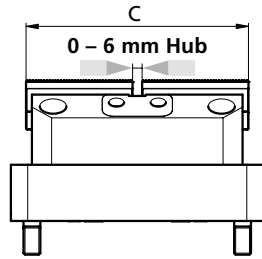
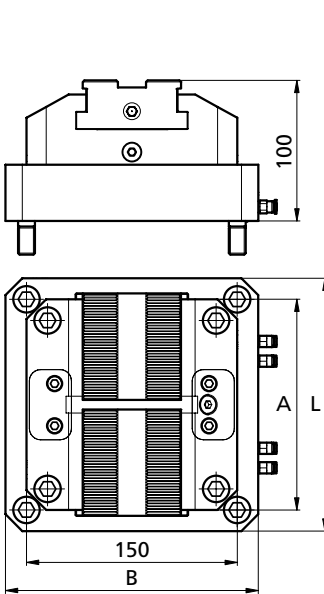

ZSP150L100

- 1 1x TB190122
- 2 1x TN100525
- 3 1x TB140209
- 4 1x TB190092
- 5 1x TN100595
- 6 1x TN100894
- 7 7x TN100013
- 8 4x TN100596
- 9 6x TN100914
- 10 2x TN100917
- 11 2x TN100592
- 12 1x TB190125
- 13 2x TB190087
- 14 1x TB190085
- 15 2x TN100021
- 16 2x TB190123
- 17 2x TN100453
- 18 1x TB190095
- 19 1x TB190086
- 20 2x TN100916
- 21 4x M6X18ISO4762
- 22 5x TN100014
- 23 1x TB190094
- 24 8x TWPAS1240
- 25 5x TN100009
- A = 150
- L = 180
- B = 180
- kg ~16



Bedienungsanleitung zu diesem pneumatischen Zentrischspanner
Operating instructions for this pneumatic self centering vise

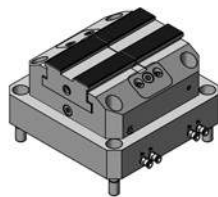

Bedienungsanleitung zu diesem pneumatischen Zentrischspanner
Operating instructions for this pneumatic self centering vise

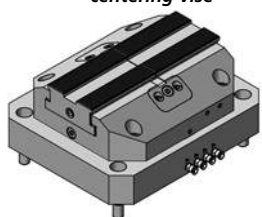

ZSP250L100

- 1 1x TB190083
- 12 1x TB190091
- 16 2x TF190780
- A = 200
- L = 240
- B = 200
- C = 250
- kg ~25,5



Bedienungsanleitung zu diesem pneumatischen Zentrischspanner
Operating instructions for this pneumatic self centering vise

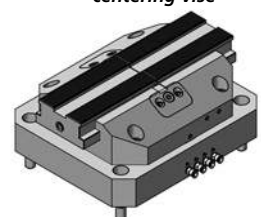

Spannkraft siehe Seite
Clamping force see page

161

Bestellbeispiel / Ordering example: ZSP150L100

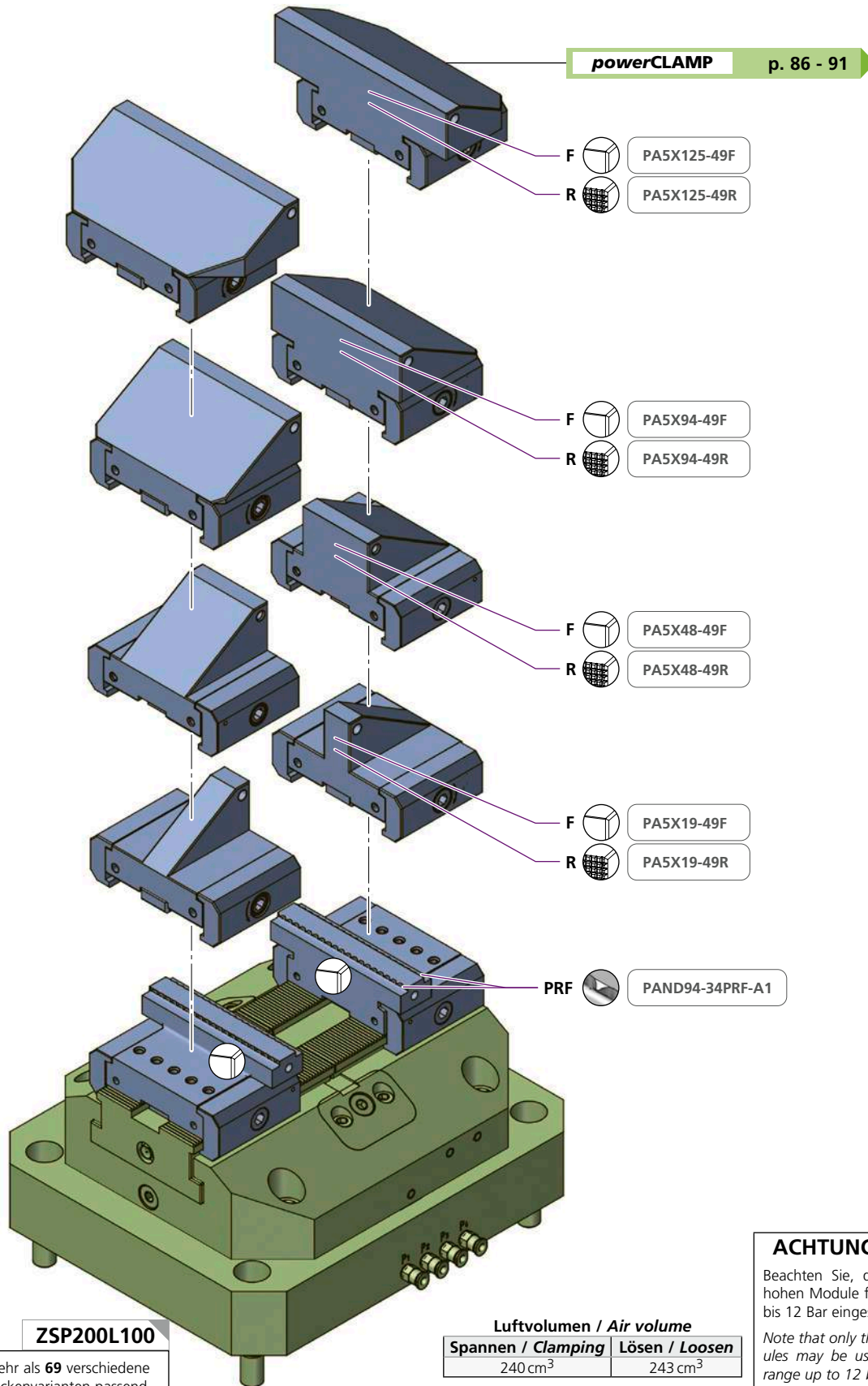

ZSP200L100

Mehr als **69** verschiedene Backenvarianten passend zu dieser Schnellwechelschnittstelle.

More than **69** different jaw modules to match this rapidly changing interface.

Luftvolumen / Air volume

Spannen / Clamping	Lösen / Loosen
240 cm ³	243 cm ³

	Druck / Pressure		Spannkraft / Clamping force		
	Bar		~daN	~(lb)	~t
Druckübersetzer Pressure intensifier 1:2	5	=	1'100	2'420	1,1
	8	=	1'500	3'300	1,5
	10	=	2'000	4'400	2,0
	12	=	2'400	5'290	2,4

ACHTUNG / CAUTION

Beachten Sie, dass nur die 34 mm hohen Module für den Druckbereich bis 12 Bar eingesetzt werden dürfen.

Note that only the 34 mm high modules may be used for the pressure range up to 12 bar.

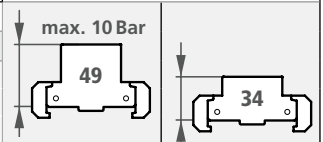

Bestellbeispiel / Ordering example: 1 x ZSP200L100 & 2 x PA5X48-49F

Separat bestellen / Order separately

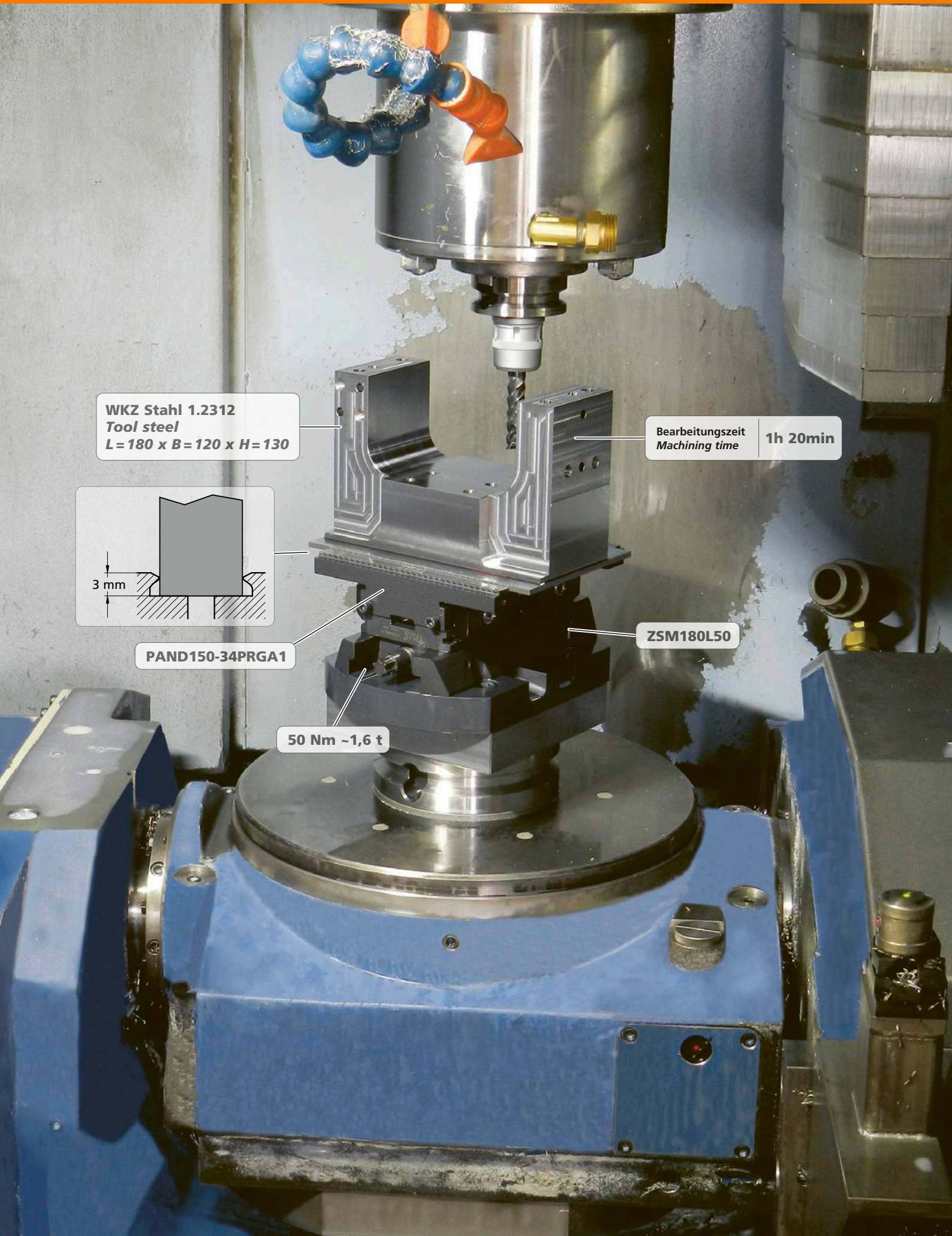

WKZ Stahl 1.2312
Tool steel
L = 180 x B = 120 x H = 130

Bearbeitungszeit
Machining time 1h 20min

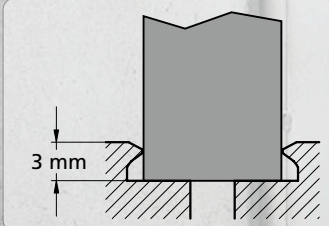

PAND150-34PRGA1

ZSM180L50

50 Nm ~1,6 t



microCLAMP



compactCLAMP

Mehrfachspannsystem / Multiple workholding system

**Nur noch Ersatzteile und
Nachlieferungen!
Keine Compact Clamp
Neuentwicklungen mehr!**

Beim Compact Clamp lassen sich die Spannmodule auf einer Basisschiene mittels Passstiften massgenau positionieren. Die Schienen sind mit einem Lochraster mit 7,5 mm Teilung, die Spannmodule mit einer 10 mm-Teilung versehen. Dank Anwendung des Nonius-Prinzips entsteht ein kleinstmöglicher Positionierschritt von 2,5 mm. Bei einem Backenhub von 4 mm ist es somit möglich, an jedem beliebigen Punkt der Schiene nullpunktbezogen zu spannen. Ab 20 mm ist die Bearbeitung von drei Seiten möglich. Da das Spannmodul mit vier Schrauben in den T-Nuten verankert wird, ist es sinngemäss auch möglich, an Stelle der Original-Spannmodule individuelle Vorrichtungen und Sonderbacken zu befestigen. Das Compact Clamp Spannsystem ist ein System für Tüftler. Praktisch keine Spannprobleme bleiben damit ungelöst. Dafür sind die Umrüstzeiten etwas länger als beim Power Clamp. Compact Clamp-Basisschienen sind in den Längen 113 - 750 mm lieferbar. Die angebotenen Befestigungsrastrer sind 40 und 50 mm. Neben den Stahlschienen werden für leichte Arbeiten auch Schienen aus Aluminium hergestellt.

**Only spare parts and
additional deliveries! No
more new Compact Clamp
developments!**

In the Compact Clamp, the vise modules are positioned precisely on a base rail by means of alignment pins. On the base rail, positioning holes are located on a 7,5 mm grid, while on the vise module there is one with a 10 mm spacing. Following the vernier principle, the smallest possible positioning step is therefore 2,5 mm. With a jaw movement of 4 mm it is therefore possible to clamp the workpiece in any desired position with a known distance to program Zero (original datum face). From 20 mm up, three sided machining is possible. Special jaws or dedicated fixtures may easily be bolted onto the rails in place of standard vise modules if the need arises. They may be anchored in the T-slots and located by using alignment pins in the positioning holes. Hence the Compact Clamp is the ideal workholding system for "do it yourself" customers. Change over times are longer than with the Power Clamp, though. Available Compact Clamp base rails lengths: 113 - 750 mm. The fastening grids on the rails are 40 and 50 mm. In addition those made of steel we also produce rails made of aluminum for light work.



Sie können den
Katalog unter der
folgenden Link herunter-
terladen!

You can download the
catalogue at the fol-
lowing download
link!



Einleitung | *Introduction* 166 - 167

Anwendungsbeispiele | *Examples of application* 168 - 171



Spannkraft und Drehmoment | *Workholding force and torque* 173

Vorrichtungsbau - Präge- und Anschlagmodule (Linear)
For dedicated fixture - stamping- and end modules (linear) 174 - 176

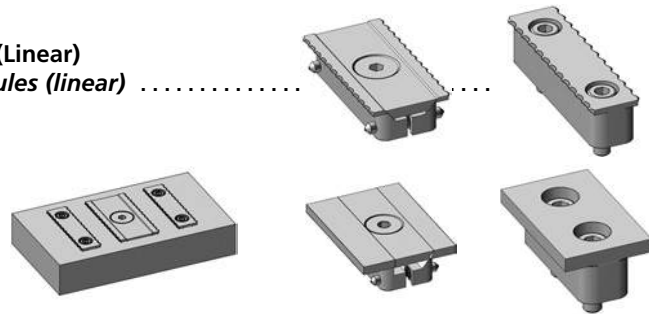

Niederzugspannmodule | *Pull down clamp modules* 177 - 195

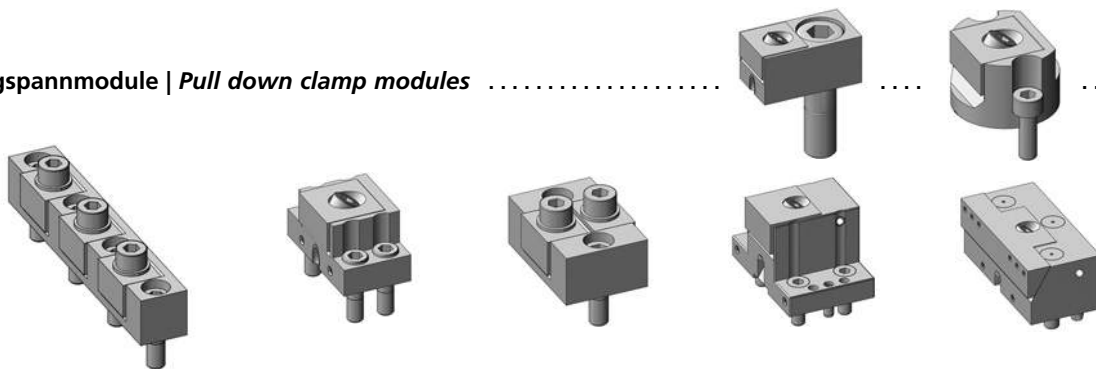

Linearspannmodule | *Linear clamping modules* 196 - 203

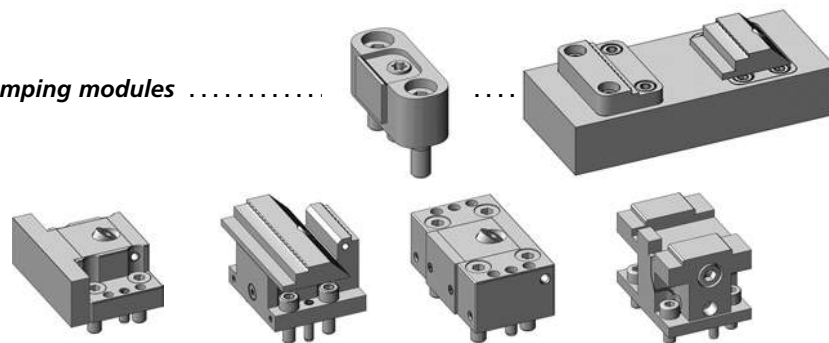

Zubehör | *Accessories* 204 - 205



Zum Aufbau kundenspezifischer Sondervorrichtungen für höchste Werkstückdichte im Arbeitsraum von Bearbeitungszentren ist das Spannsystem Micro Clamp ausgelegt (Spezielle Anschlagbacken, siehe Bild). Sehr kompakte Spannmodule mit Prägebacken verwirklichen eine zuverlässige Aufspannung bei nur etwa 2 mm Verlust an Rohmaterial

Clamps for dedicated fixtures for high density to get your best output from your machine. Clamping modules in different sizes and shapes and jaws with serrations also flat and carbide coated are available.

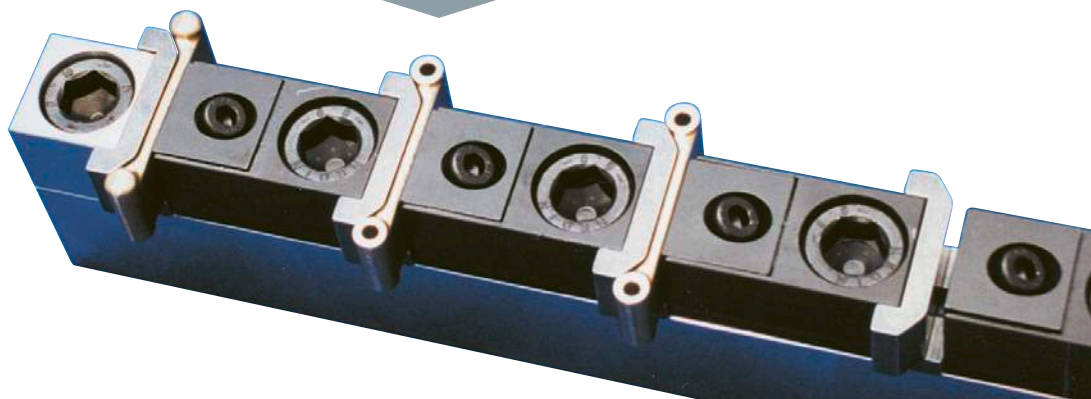

Kleinst-Spannmodule für den Vorrichtungsbau. *Extremely small clamping modules for dedicated fixtures.*

Hohe Spanndichte

Die Spannmodule haben auf der Vorderseite eine Spannbacke, die Rückseite ist zu den Befestigungsbohrungen massgenau geschliffen oder gefräst. Damit kann diese Anschlagfläche für das folgende Werkstück genutzt werden. Diese Anordnung lässt eine sehr hohe Spanndichte zu. Beim kleinsten Micro Clamp-Modul sind nur 15 mm Spannabstand erforderlich.

High workholding density

These clamping modules have a clamping jaw on the front, while rear is precisely ground or milled with reference to the fixing holes. This means that it can be used as a datum face for the following workpiece. This arrangement allows very high clamping densities. Only 15 mm clamping clearance is needed between workpieces using the smallest Micro Clamp module.

- Maximale Spannkraft der Module 2,8t (28'000N)
- Benötigter Platz zwischen den Werkstücken ab 15 mm
- Spannhub ab 1,5 mm
- Genaue Positionierung durch Passschrauben und Positionierstifte

- *Clamping force up to 2,8t (28'000N)*
- *Space between workpieces only 15 mm*
- *Stroke of jaw from 1,5 mm*
- *Precise positioning by ground shoulder screws or dowel pins*



Ein grosses Angebot an verschiedensten Spannmodulen.
A wide range of clamp modules in different sizes are available

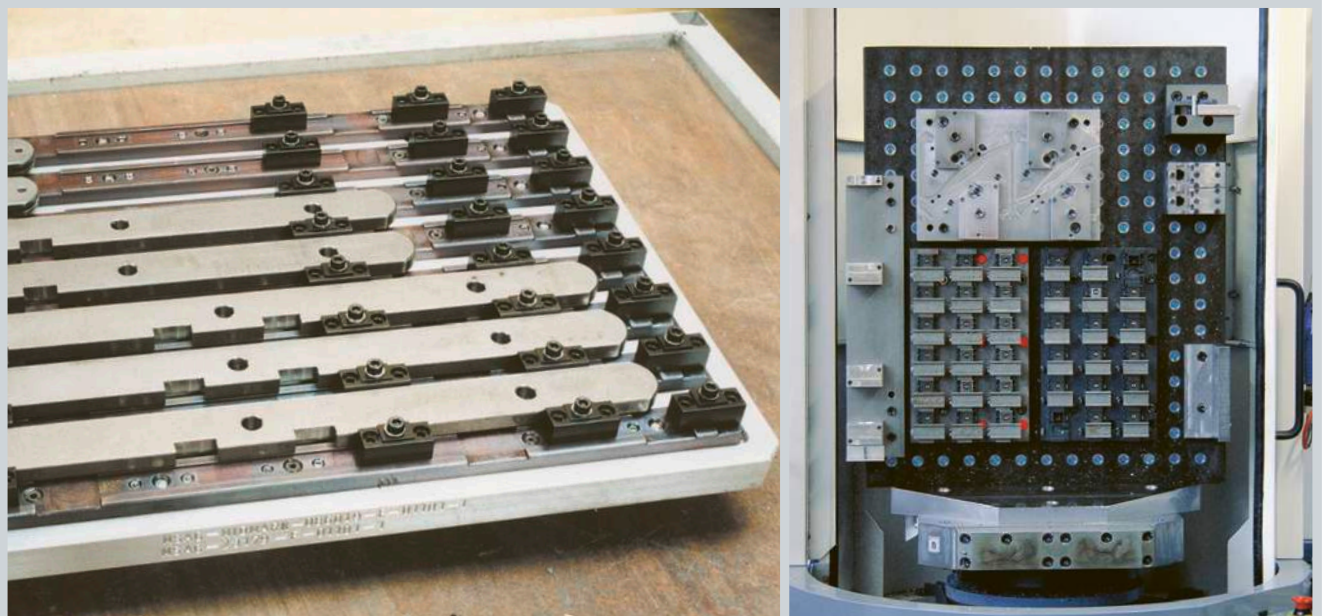

Hohe Spanndichte für Werkstücke in grossen Stückzahlen.
High density fixture plates for repeating orders in high quantities

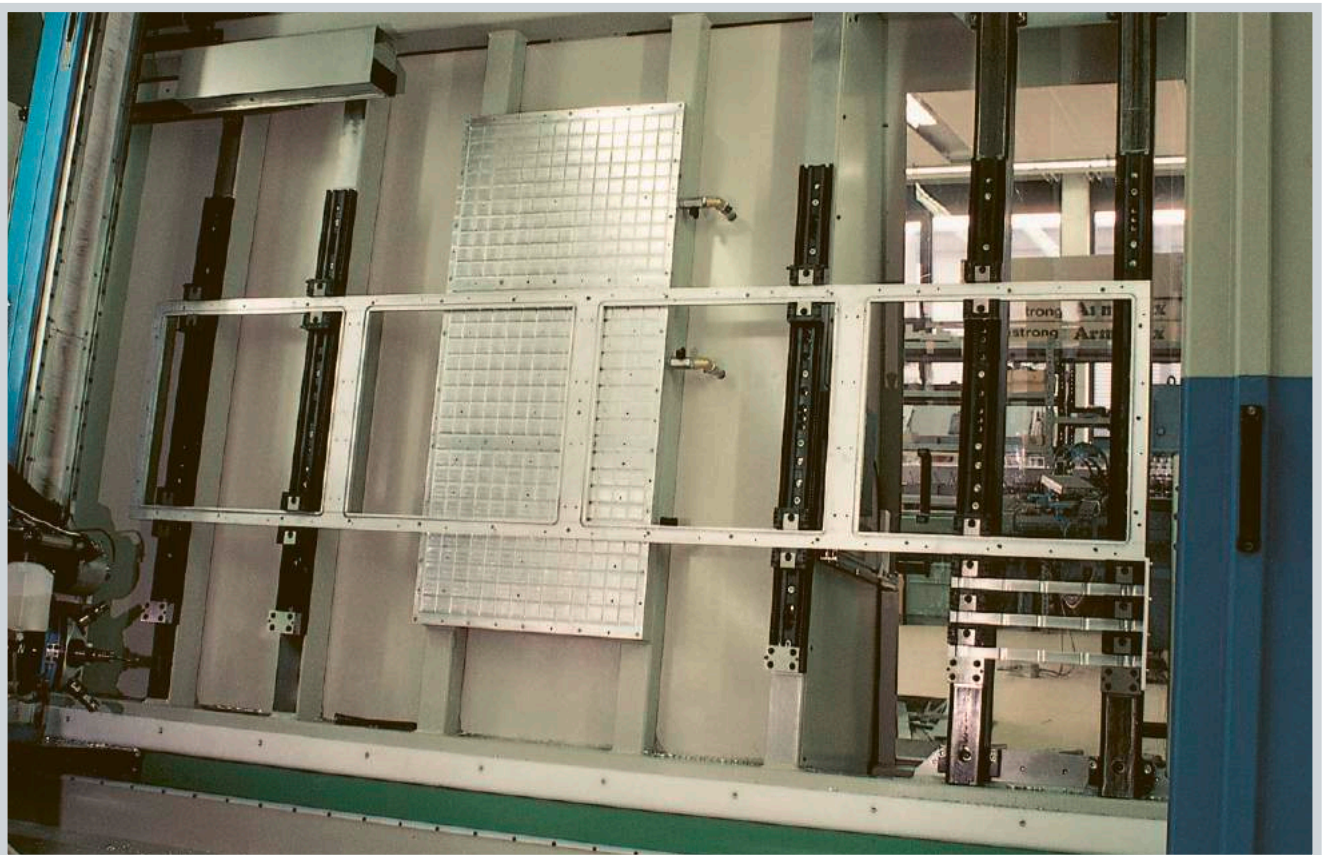

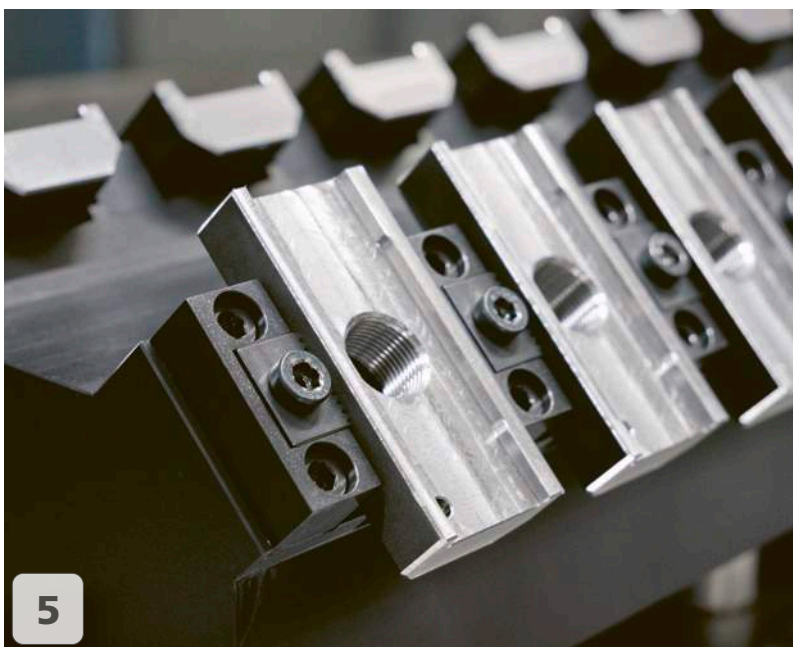
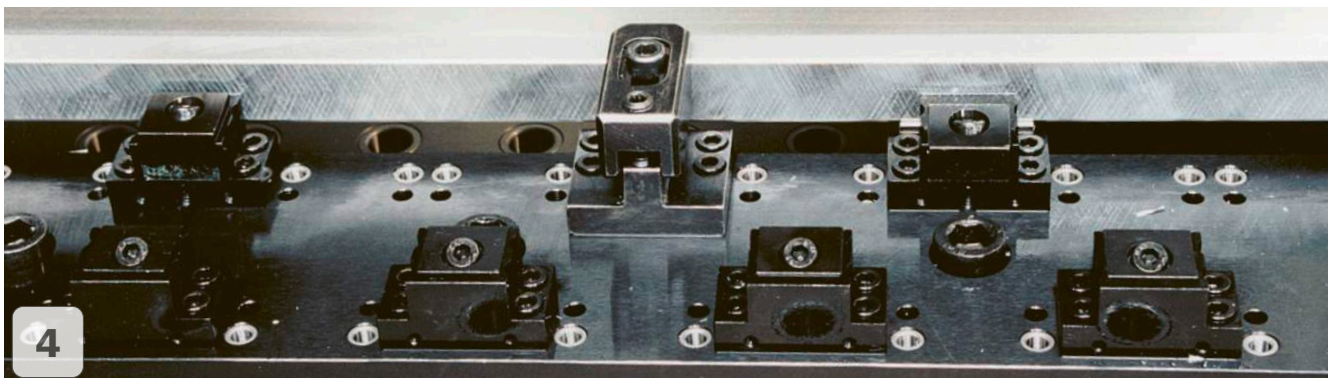
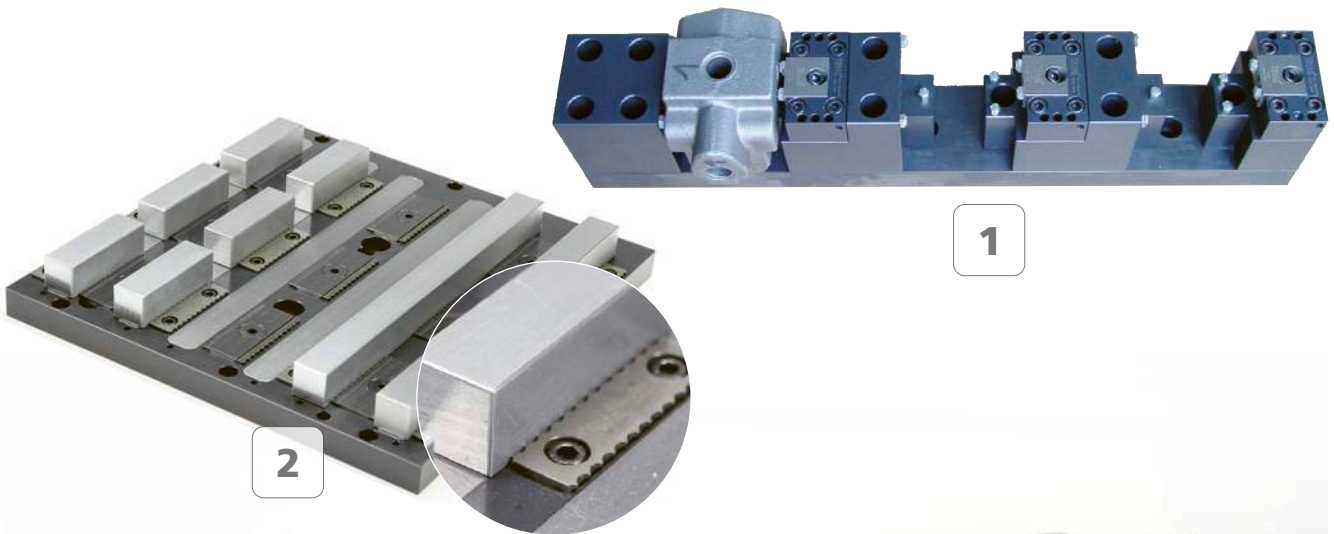



7 72 Teile sind hochgenau gespannt unter 10 my. Die Vorrichtungen sind auf einem EROWA ITS O-Punkt Spannsystem aufgebaut
72 parts are clamped within 10 microns the clamp fixtures are set up on a EROWA ITS palleting system

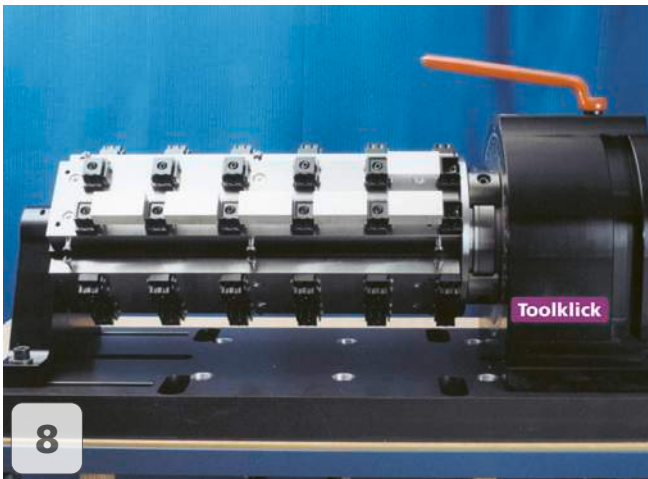

8

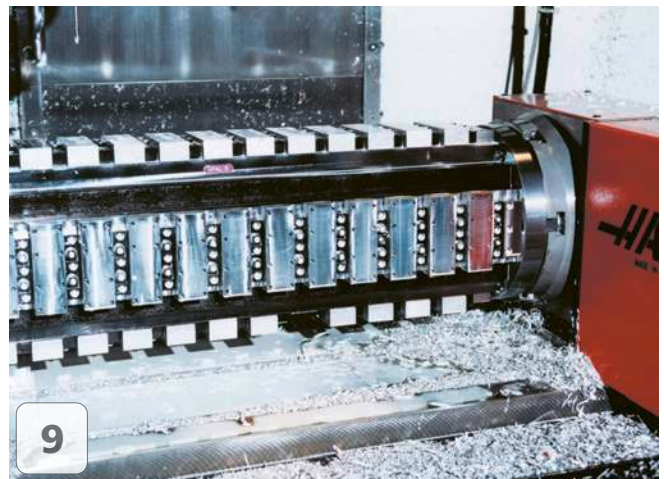

9

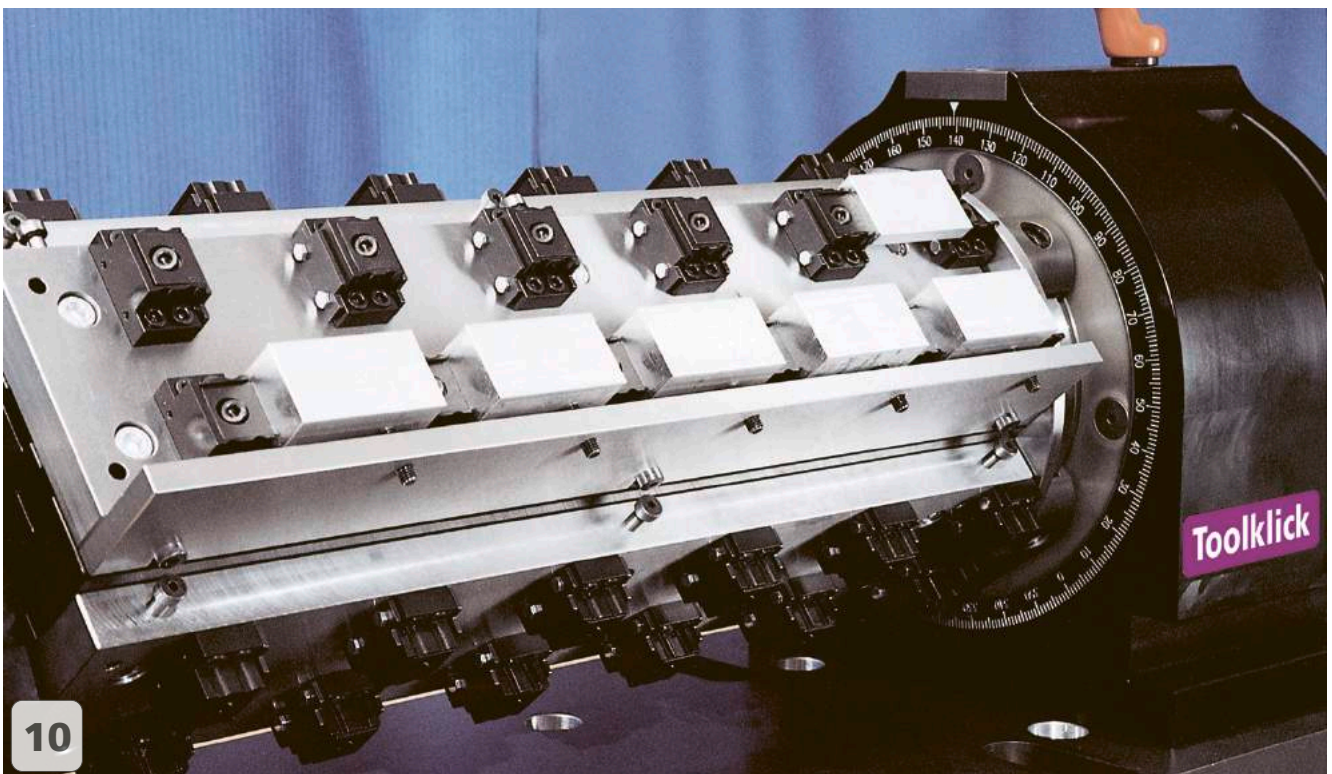

10



11 84 Teile sind gespannt mit Micro Clamp und werden jeweils nachts unbemannt produziert
 84 parts are clamped with Micro Clamp and are machined always at right unmanned



12

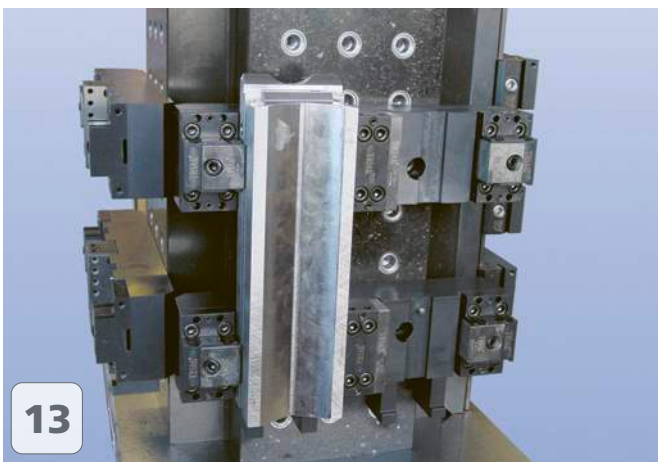

13



16

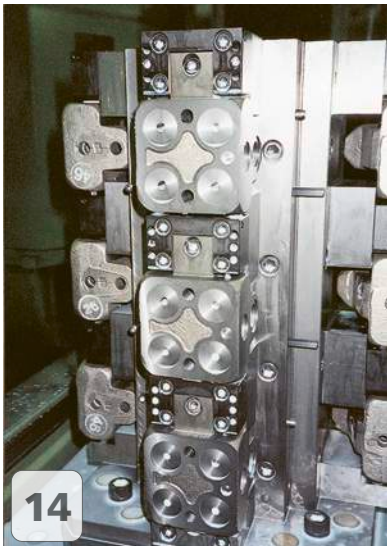

14



15

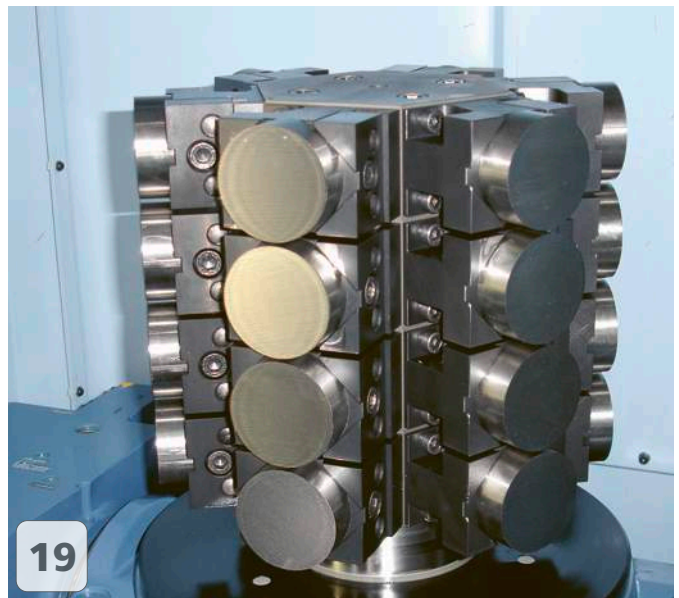
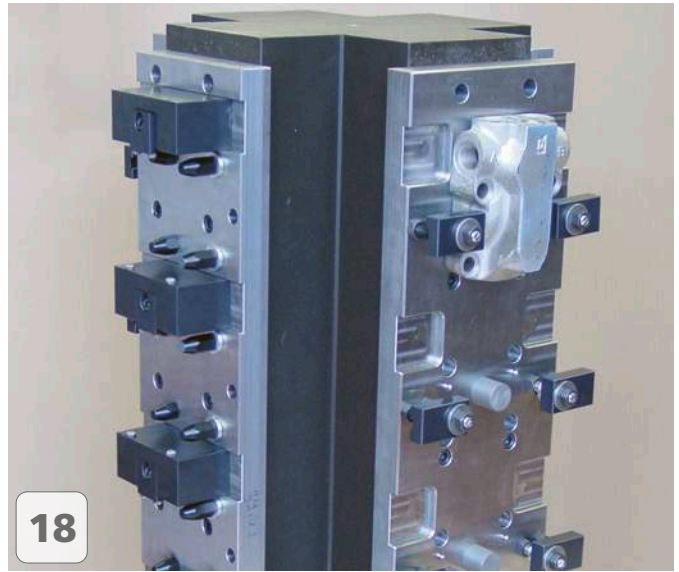
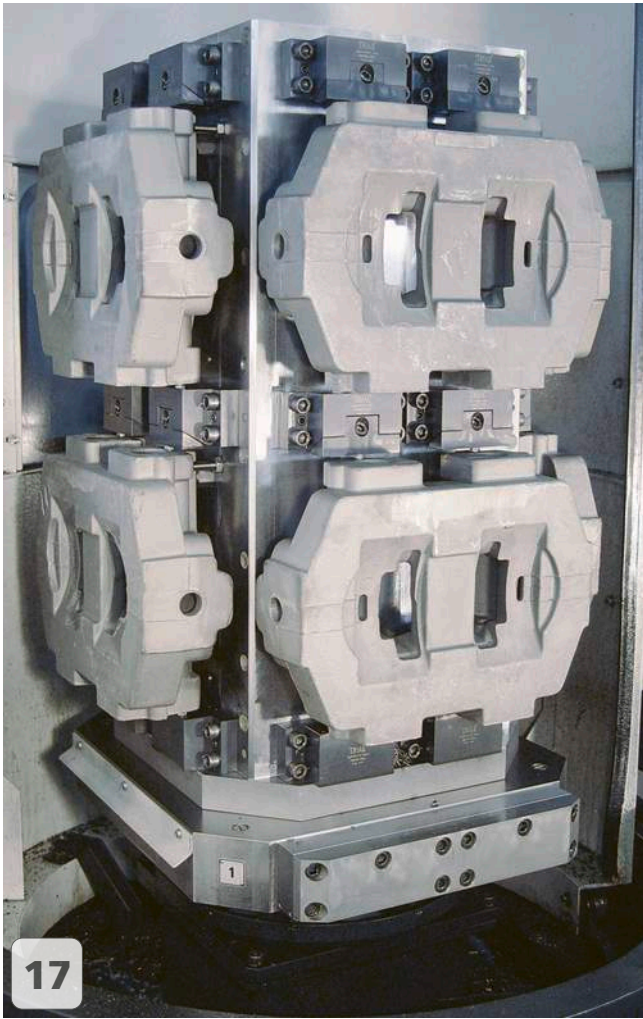

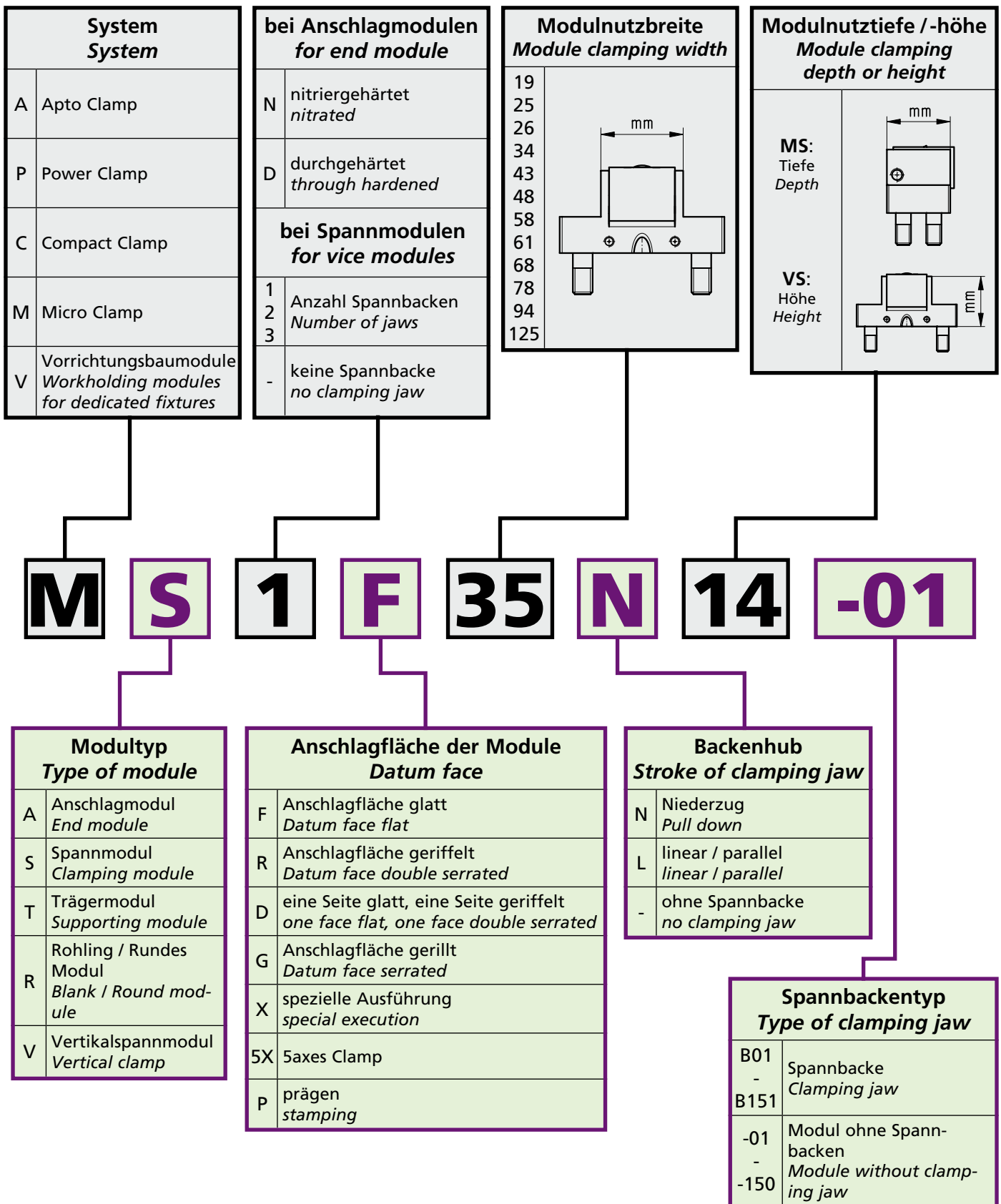

ACHTUNG / CAUTION

WICHTIG: Die im Micro Clamp Kapitel angegebenen Drehmomente sind die absoluten Maximalwerte. Über die Spannkraften gibt die untenstehende Tabelle Auskunft.

IMPORTANT: The torque numbers specified in the Micro Clamp chapter represent the absolute maximum. The table at the bottom of this page provides further information on the workholding forces.

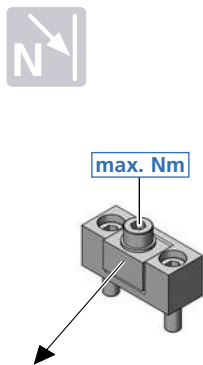
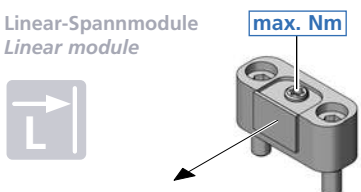
Niederzug-Spannmodule Pull down module	MC-Module	Schraube Screw	Drehmoment Torque		Spannkraft Workholding force		
			Nm	(lb-ft)	~daN	~(lb)	~t
	MR1F 30N23 -07	M5	10	7,4 =	1020	2250	1,02
	MS1F 22N40 -07		10	7,4 =	1020	2250	1,02
	MS1F 24N22 -07		10	7,4 =	1020	2250	1,02
	MS1R/F 25N25 -13	M6	15	11 =	1520	3350	1,52
	MS1F 35N14 -01	M5	10	7,4 =	1020	2250	1,02
	MS1F 35N22 -01		10	7,4 =	1020	2250	1,02
	MS2X 25N23 -01		10	7,4 =	1020	2250	1,02
	MS2F 60N14 -01		10	7,4 =	1020	2250	1,02
	MS3F 85N14 -01		10	7,4 =	1020	2250	1,02
	VS1R 19N35 -20		M6	15	11 =	1520	3350
	VS1R 26N35 -26	M8	25	18,4 =	2100	4630	2,10
	VS1R 38N50 -60		25	18,4 =	2100	4630	2,10
	VS1R/F 41N30 -60		25	18,4 =	2100	4630	2,10
	VS1R/F 80N30 -36		25	18,4 =	2100	4630	2,10
	VS1R 80N50 -36		25	18,4 =	2100	4630	2,10
	VS1R/F 80N30 -60		25	18,4 =	2100	4630	2,10
	VS1R 80N50 -60	M10	25	18,4 =	2100	4630	2,10
	VS1R/F 125N49 -95		40	29,5 =	2800	6170	2,80
VS2R 80N30 -60	25		18,4 =	2100	4630	2,10	
VS2F 90N30 -60	25		18,4 =	2100	4630	2,10	
Linear-Spannmodule Linear module 	MS1F (MS1R) 35L14 -152	M6x0,5	10	7,4 =	570	1260	0,57
	MS2P (MS2P) 58L14 PRG15	M8	15	11 =	600	1320	0,6
	MS2F (MS1F) 58L14 W251		15	11 =	600	1320	0,6
	VS1R 26L35 -31		25	18,4 =	2100	4630	2,10
	VS1R/F 41L30 -51		25	18,4 =	2100	4630	2,10
	VS1R/F 80L30 -51		25	18,4 =	2100	4630	2,10
	VS1X 68L20 -105		40	29,6 =	1600	3530	1,60
	VS1X 59L60 K	M10	50	37 =	1880	4140	1,88
	VS1X 59L60 H5		50	37 =	1640	3620	1,64



Schraube Screw	Drehmoment Torque		Spannkraft Workholding force			
M5 + M6	4	3 =	500	1100	0,50	
	5	3,7 =	580	1280	0,58	
	6	4,4 =	690	1520	0,69	
	7	5,2 =	780	1720	0,78	
	8	5,9 =	880	1940	0,88	
	9	6,6 =	980	2160	0,98	
	10	7,4 =	1020	2250	1,02	
M6	12	8,9 =	1220	2690	1,22	
	14	10,4 =	1450	3200	1,45	
	15	11 =	1520	3350	1,52	
	M8	4	3 =	410	900	0,41
		5	3,7 =	490	1080	0,49
		6	4,4 =	560	1250	0,56
7		5,2 =	660	1460	0,66	
8		5,9 =	730	1610	0,73	
9		6,6 =	810	1790	0,81	
10		7,4 =	900	1980	0,90	
M10	15	11 =	1520	3350	1,52	
	20	14,8 =	1810	3990	1,81	
	25	18,4 =	2100	4630	2,10	
	10	7,4 =	400	880	0,40	
	20	14,8 =	1400	3090	1,40	
	30	22,1 =	2000	4410	2,00	
	40	29,5 =	2800	6170	2,80	

Vorrichtungsbau – Prägemodule

For dedicated fixture – stamping modules

Keilspanner in weicher Ausführung zum Bearbeiten von Formbacken.

Double angle clamps with soft jaws for making shaped forms.

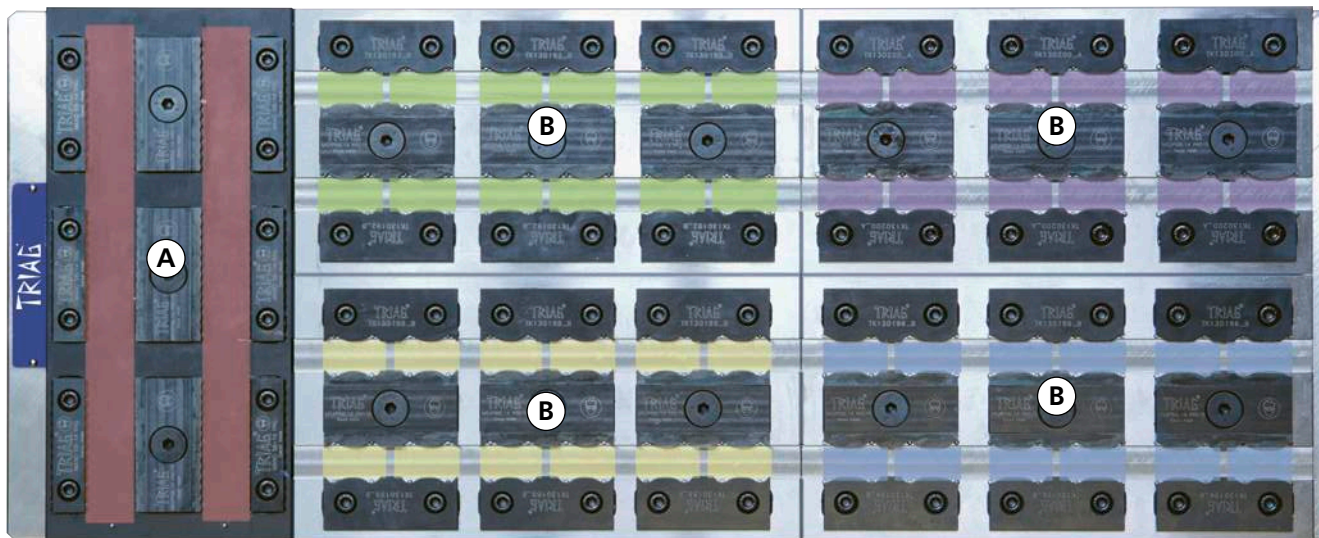

A Prägbacken Spanntiefe 1,8 mm
12 Werkstücke werden hergestellt
*First clamp 12 parts with stamping jaws
clamping depth 1,8 mm*

B 4 x 12 verschiedene Teile werden in der 2. Spannung bearbeitet
*4 times 12 different parts are machined
in the second operation*

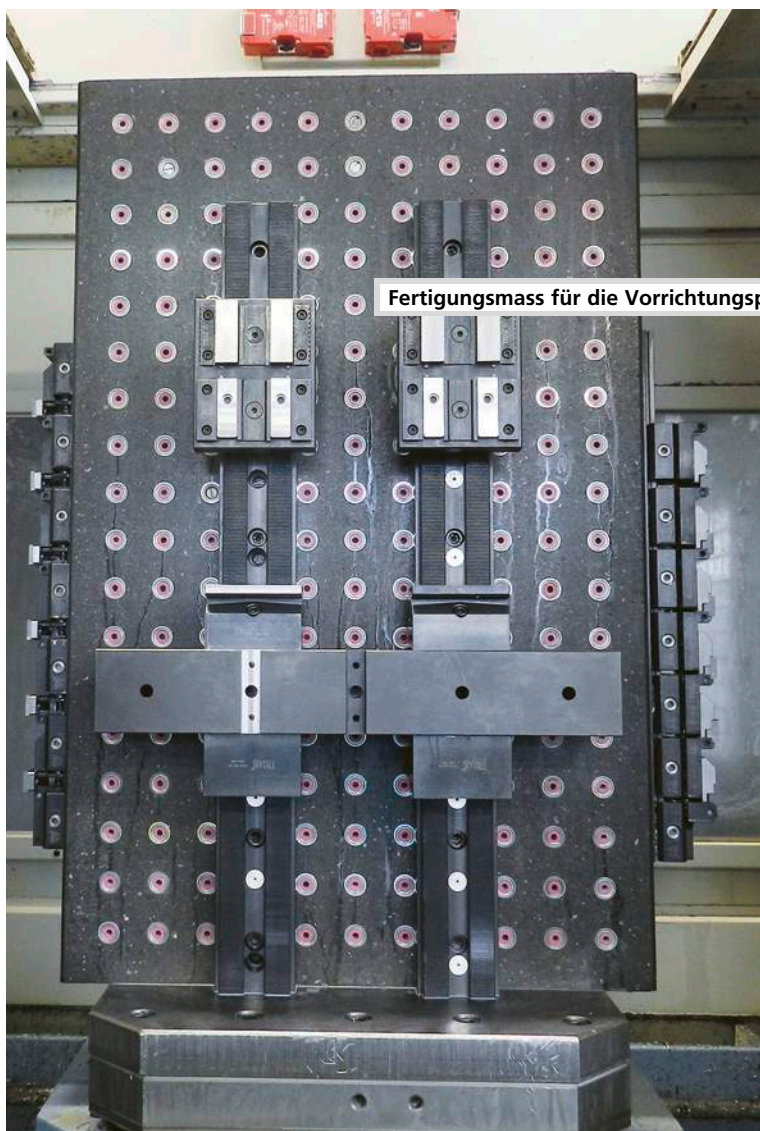

Fertigungsmass für die Vorrichtungplatte: / Machining data for the fixture plate: p. 175

Fräser / Milling cutter

Der abgebildete Fräser benötigt man für die Herstellung der «Kerben».
Siehe Fertigungsmasse für die Vorrichtungplatte Seite 175.

*The illustrated milling cutter is required for the production of "notches".
Manufacturing drawing for the fixture plate on page 175.*

45°	d	D	L1	H	z	L
TK150057	6	6,0	24,0	1,5	3	58

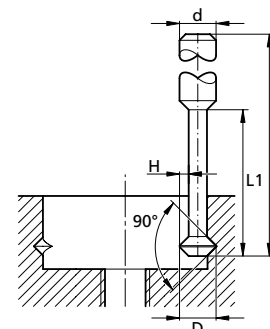

Fertigungsmasse für die Vorrichtungplatte / Machining data for the fixture plate

<p>Mass X (X1) = B + 24 mm Beispiel: Bauteilbreite = 14 mm</p> <p>Dimension X (X1) = B + 24 mm Example: Width of component part = 14 mm</p> <p>Taschenabstand X = 14 + 24 = 38 Das ergibt eine Einlegeluft von 0,8 mm (Hub bis 2,7 mm)</p>	<p>Mass X2 = B + 33,5 mm Beispiel: Bauteilbreite = 14 mm</p> <p>Dimension X2 = B + 33,5 mm Example: Width of component part = 14 mm</p> <p>Taschenabstand X = 14 + 33,5 = 47,5 Das ergibt eine Einlegeluft von 0,8 mm (stroke till 2,7 mm)</p>

Hub bis / Stroke till = 2,7 mm

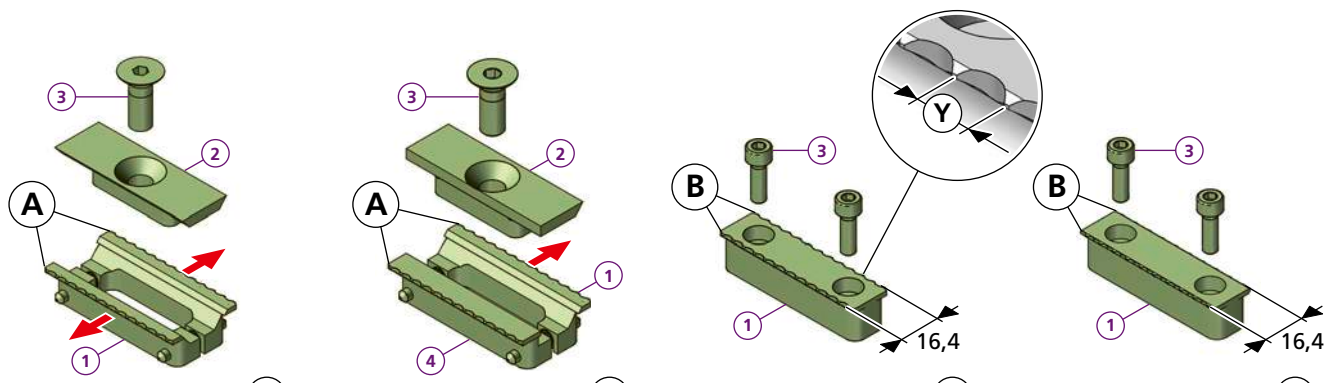
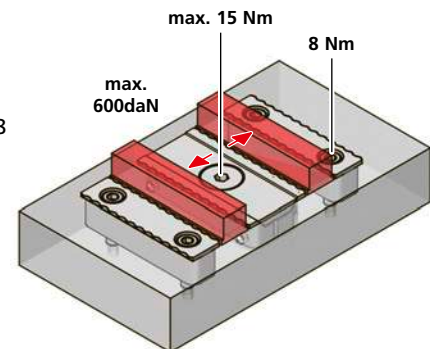
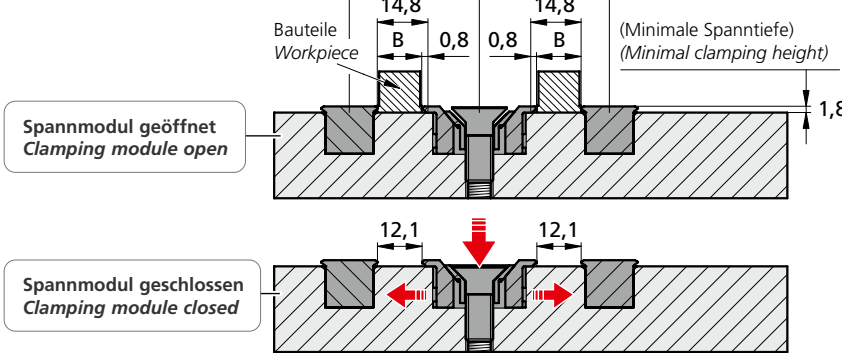

MS2P58L14PRG15

- 1 2x TK120225
- 2 1x TK120227
- 3 1x M8X22DIN7991

Y 4,7 mm
i 57HRC
kg ~0,12

MS1P58L14PRG15

- 1 1x TK120225
- 2 1x TK120721
- 3 1x M8X22DIN7991
- 4 1x TK120720

Y 4,7 mm
i 57HRC
kg ~0,12

MAND58-14PRG

- 1 1x TK120226
- 3 2x M5X16ISO4762

Y 4,7 mm
i 57HRC
kg ~0,08

MAND58-14PRG6

- 1 1x TB150282
- 3 2x M5X16ISO4762

Y 6,0 mm
i 57HRC
kg ~0,08

Zum Erstellen Ihrer individuellen Formbacke:
 Schnittzeichnung zum Ermitteln der maximalen Bearbeitungsprofiltiefe
If a dedicated jaw is being machined:
 Sectional drawing to determine the maximum machining depth

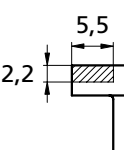

für / for TK120531 | TK120531 | TK120529 | TK160554

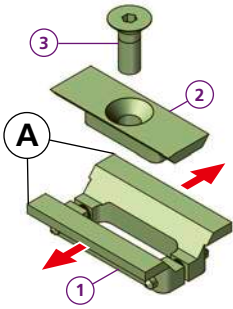
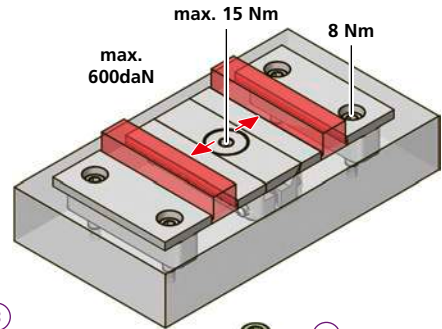

MS2F58L14W251

- 1 2x TK120531
- 2 1x TK120227
- 3 1x M8X22DIN7991

i *

kg ~0,12

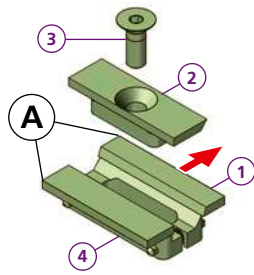

MS1F58L14W251

- 1 1x TK120531
- 2 1x TK120721
- 3 1x M8X22DIN7991
- 4 1x TH130566

i *

kg ~0,12

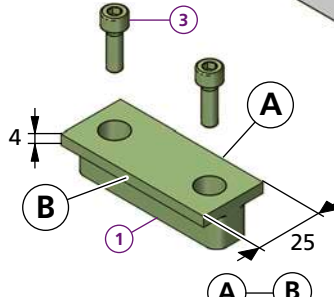

MANF58-14W25

- 1 1x TK120529
- 3 2x M5X16ISO4762
- i *

MANF58-14F25

- 1 1x TK150033
- 3 2x M5X16ISO4762
- i HV700 x 0,2mm

kg ~0,11

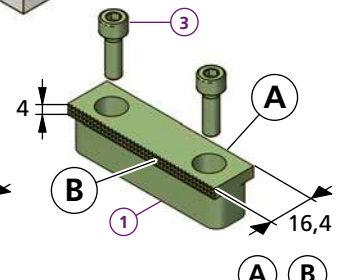

MANF58-14RF

- 1 1x TB160563
- 3 2x M5X16ISO4762

i HV700 x 0,2mm

kg ~0,11

p. 175 Fertigungsmass für die Vorrichtungplatte: / Machining data for the fixture plate:

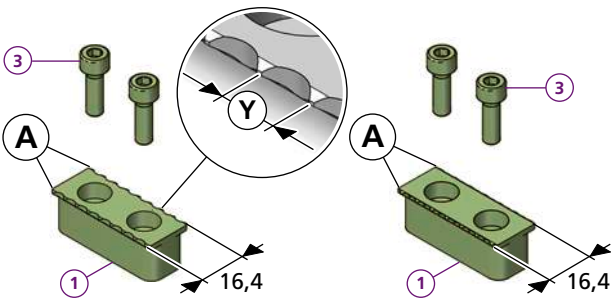

MAND38-14PRG

- 1 1x TB150234
- 3 2x M5X16ISO4762
- Y 4,7 mm

i 57HRC

kg ~0,08

MAND38-14PRG6

- 1 1x TB150283
- 3 2x M5X16ISO4762
- Y 6,0 mm

i 57HRC

kg ~0,08

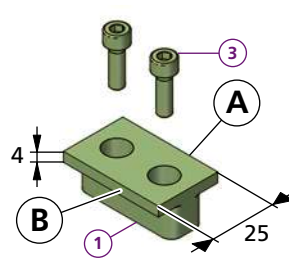

MANF38-14W25

- 1 1x TK160554
- 3 2x M5X16ISO4762
- i *

MANF38-14F25

- 1 1x TK160553
- 3 2x M5X16ISO4762
- i HV700 x 0,2mm

kg ~0,08

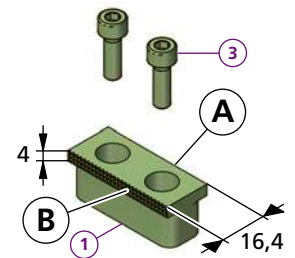

MANF38-14RF

- 1 1x TB170062
- 3 2x M5X16ISO4762

i HV700 x 0,2mm

kg ~0,08

Fertigungsmass für die Vorrichtungplatte
 Machining data for the fixture plate

für / for TB150234 | TB150283 | TK160554 | TK160553 | TB170062

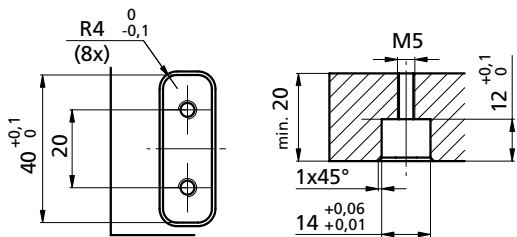

Spannmodule

Clamping module MV1F20L35BV1

microCLAMP

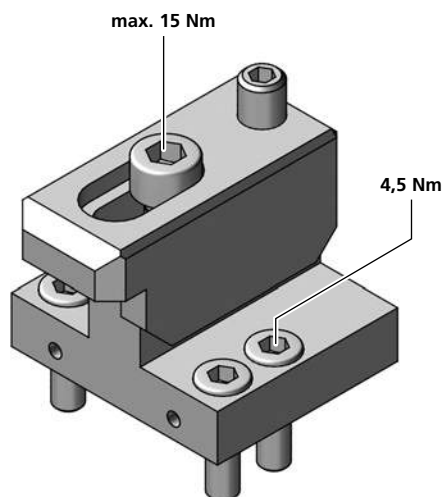
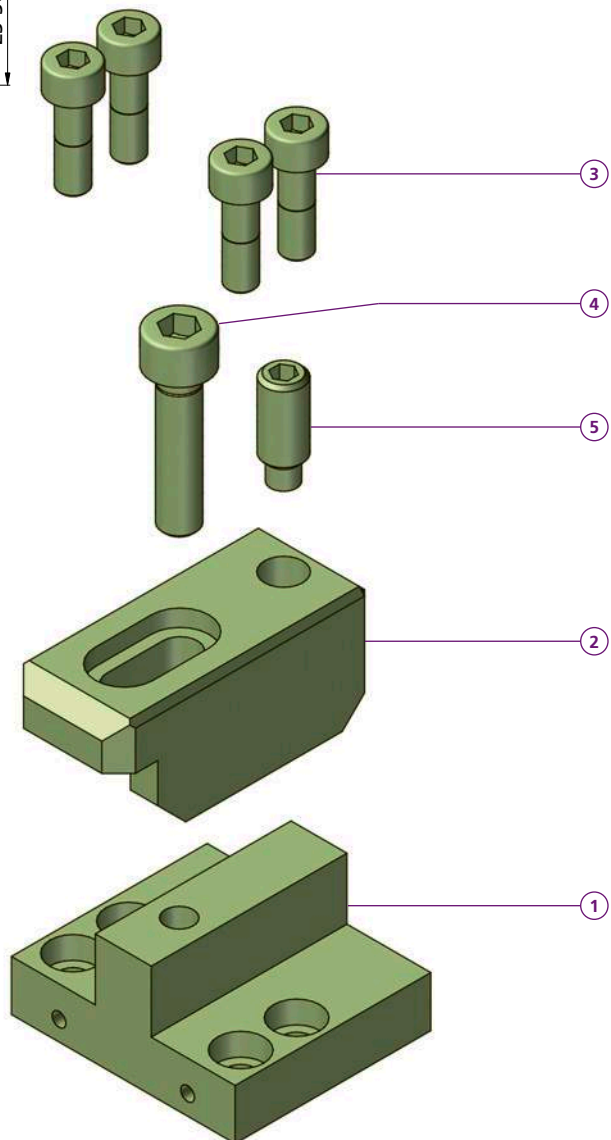
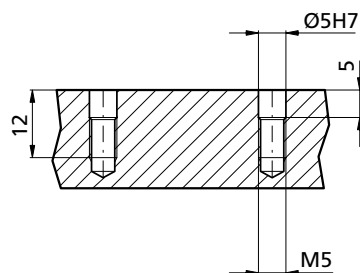
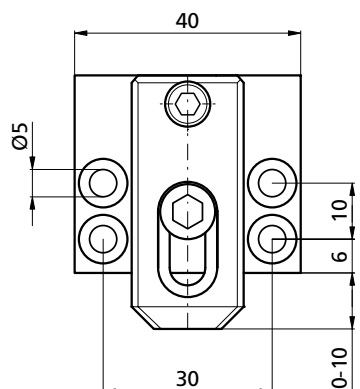
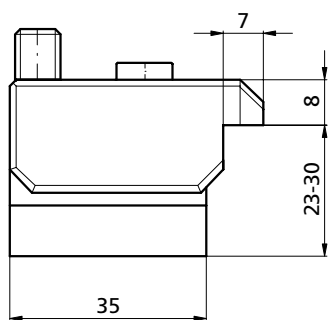
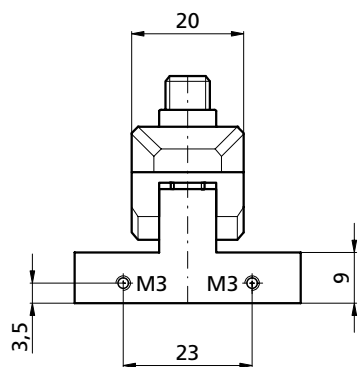

MV1F20L35BV1

- ① 1x TF140710
 - ② 1x BV1
 - ③ 4x M550
 - ④ 1x M6X25ISO4762
 - ⑤ 1x M8x20ISO4028
- kg ~0,225

Bestellbeispiel / Ordering example : MV1F20L35BV1

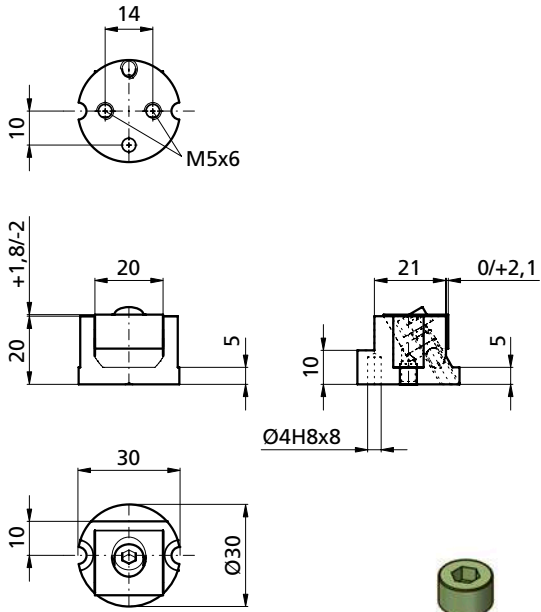

Version 2

Version 1

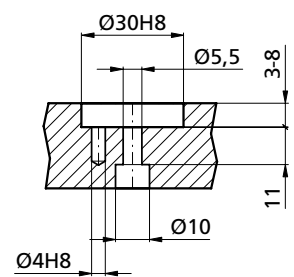
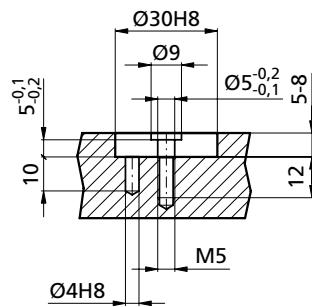
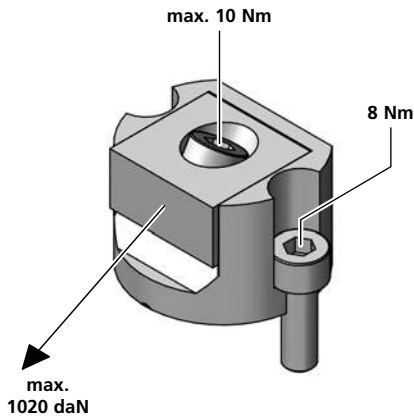
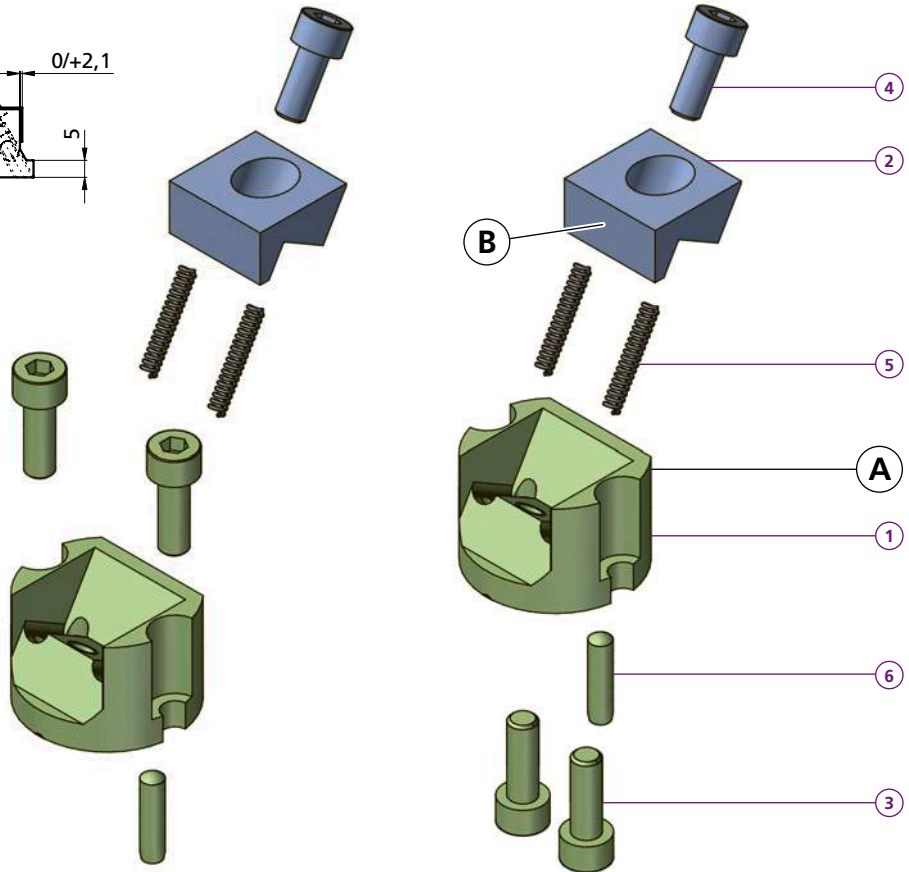

Bestellbeispiel / Ordering example: 1x MR1F30N23-07 & 1x B08

MR1F30N23-07		B07 B08 B09 B09+2 B09+5				
1	1x TF140711					
2	1x					
3	2x M5X16ISO4762					
4	1x M5X12ISO4762					
5	2x FED03018					
6	1x Ø4x14 DIN 6325					
kg	~0,095					
		C	H	L	D	i
		20	20	20	20	20
		10	10	10	10	10
		9,5	9,5	9,5	11,5	14,5
		5,5	5,5	5,5	5,5	5,5
		6	6	6	6	6
		HV700	HV700	*	*	*
		x0,2mm	x0,2mm			
kg		~0,02	~0,02	~0,02	~0,02	~0,02

B07, B08, B09

B09+2, B09+5

Separat bestellen / Order separately

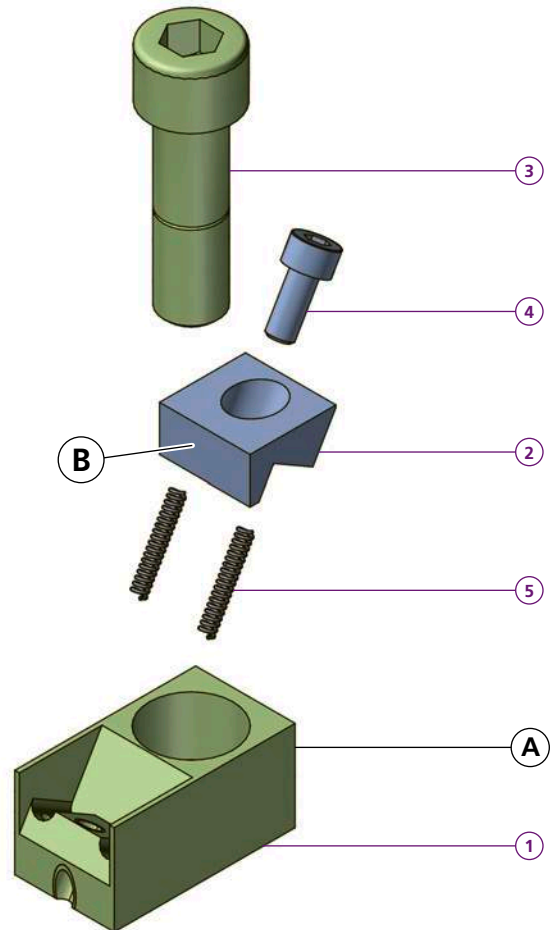
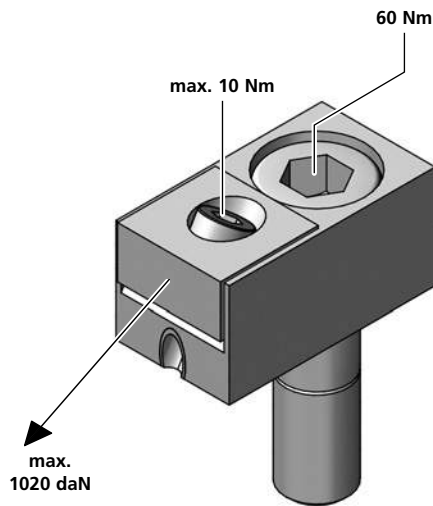
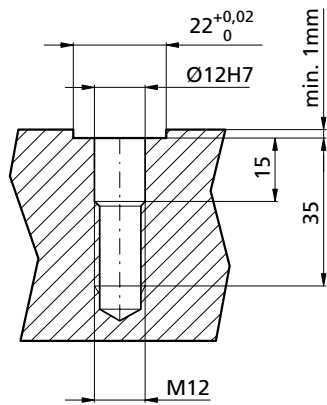
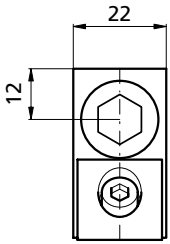
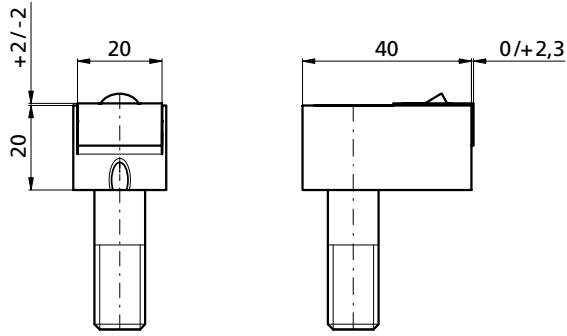

MS1F22N40-07	
1	1x TF140712
2	1x
3	1x TWPAS1240
4	1x M5X12ISO4762
5	2x FED03018
kg	~0,15

Bestellbeispiel / Ordering example: 1x MS1F22N40-07 & 1x B08					
	B07	B08	B09	B09+2	B09+5
C	20	20	20	20	20
H	10	10	10	10	10
L	9,5	9,5	9,5	11,5	14,5
D	5,5	5,5	5,5	5,5	5,5
ø	6	6	6	6	6
i	HV700	HV700	*	*	*
	x0,2mm	x0,2mm			
kg	~0,02	~0,02	~0,02	~0,02	~0,02

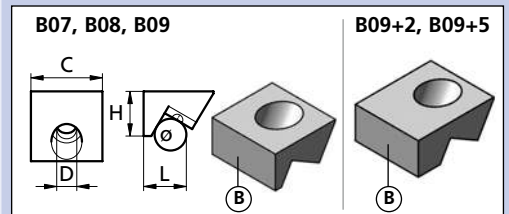

* = weicher Stahl / soft steel

Separat bestellen / Order separately

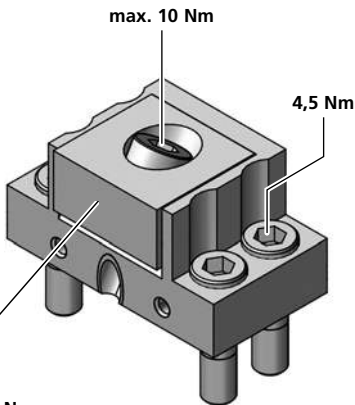
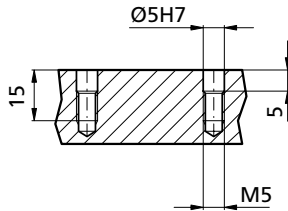
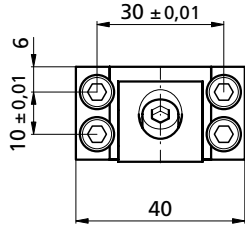
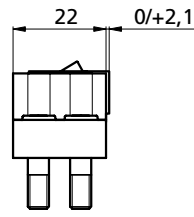
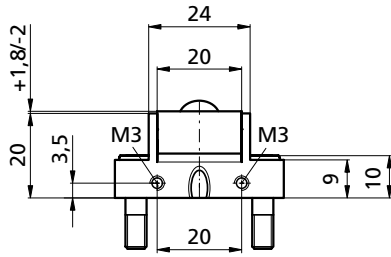

max. 1020 daN

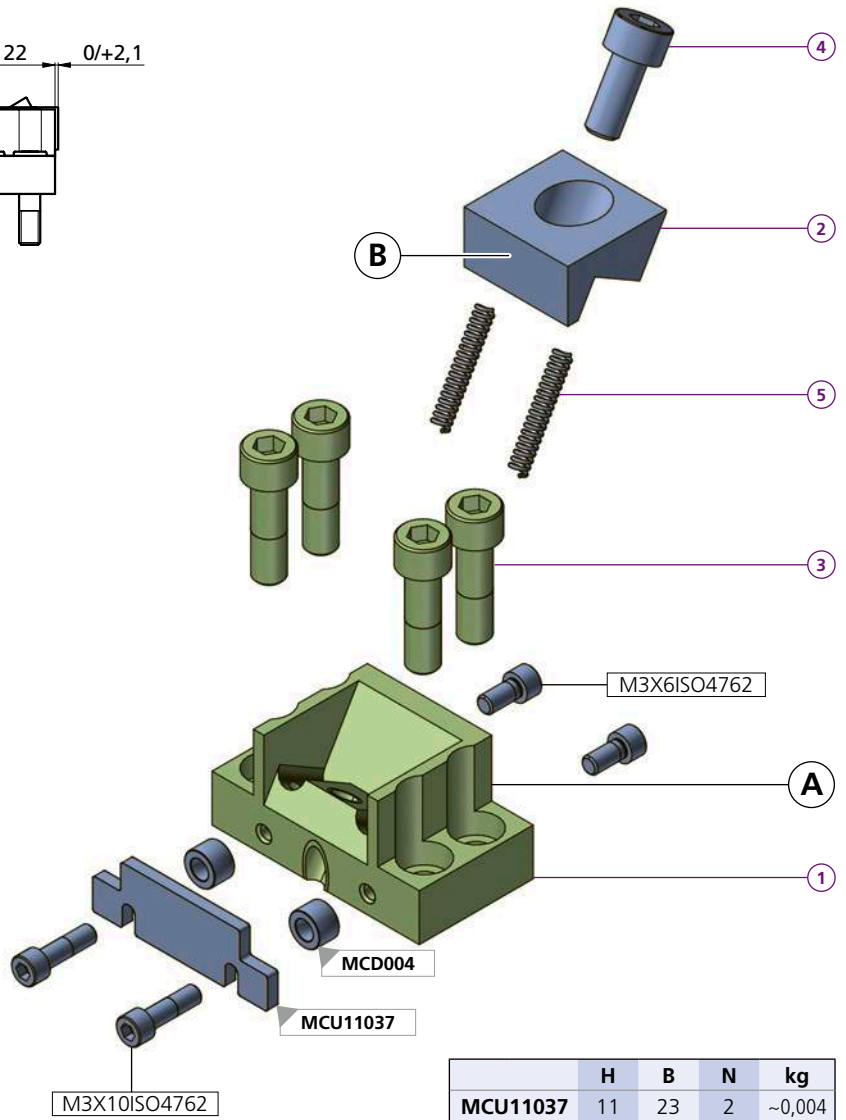

	H	B	N	kg
MCU11037	11	23	2	~0,004
MCU15037	15	23	2	~0,006
MCU18037	18	23	2	~0,008
MCU20037	20	23	2	~0,008
MCU22537	22,5	23	2	~0,008

- 2x M3X10ISO4762
- 2x M3X6ISO4762
- 2x MCD004

Achtung: Bei Spannkraften über 400 daN (0,4t) muss das Spannmodul in eine Nut eingelassen werden (Nuttiefe mindestens 1mm)

Remark: Using forces higher than 400 daN, clamps must be mounted into a slot (depth minimum 1mm)

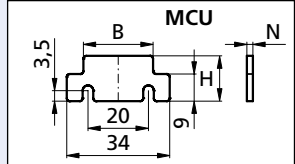
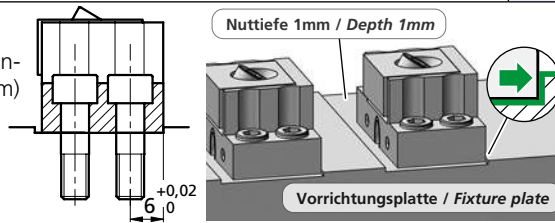

MS1F24N22-07	
1	1x TF140713
MS1R24N22-07	
1	1x TW100172-01
2	1x
3	4x MS50
4	1x M5X12ISO4762
5	2x FED03018
kg	~0,125

Bestellbeispiel / Ordering example: 1x MS1F24N22-07 & 1x B08					
	B07	B08	B09	B09+2	B09+5
C	20	20	20	20	20
H	10	10	10	10	10
L	9,5	9,5	9,5	11,5	14,5
D	5,5	5,5	5,5	5,5	5,5
ø	6	6	6	6	6
i	HV700	HV700	*	*	*
	x0,2mm	x0,2mm			
kg	~0,02	~0,02	~0,02	~0,02	~0,02

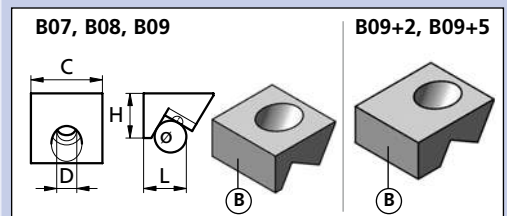

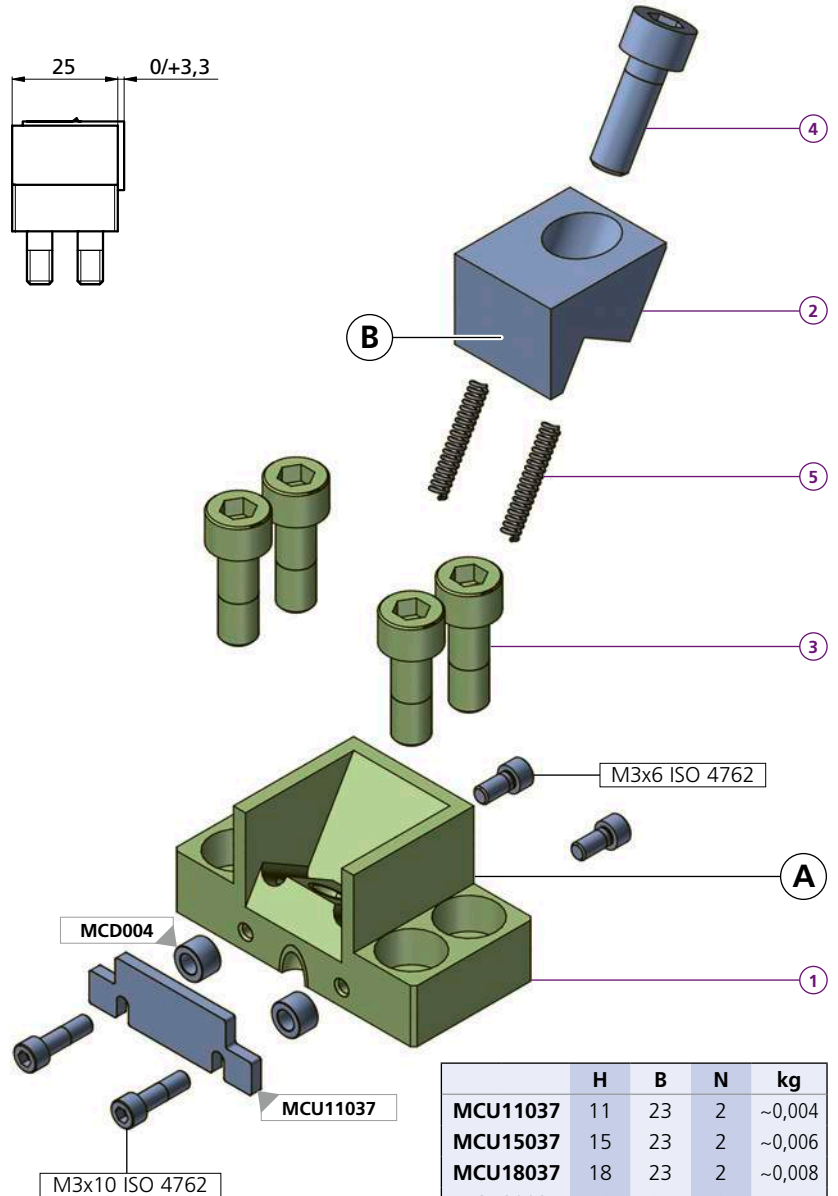
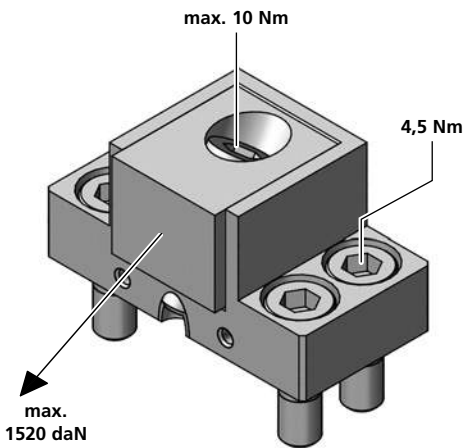
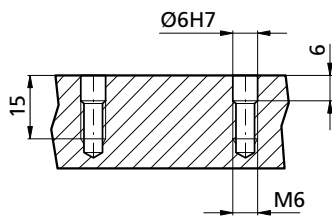
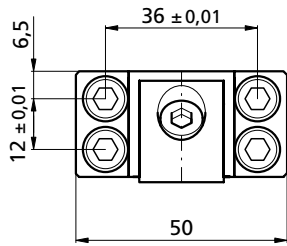
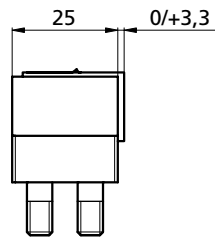
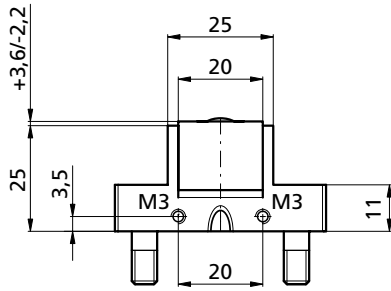

	H	B	N	kg
MCU11037	11	23	2	~0,004
MCU15037	15	23	2	~0,006
MCU18037	18	23	2	~0,008
MCU20037	20	23	2	~0,008
MCU22537	22,5	23	2	~0,008

- 2x M3X10ISO4762
- 2x M3X6ISO4762
- 2x MCD004

Achtung: Bei Spannkraften über 400 daN (0,4t) muss das Spannmodul in eine Nut eingelassen werden (Nuttiefe mindestens 1mm)

Remark: Using forces higher than 400 daN, clamps must be mounted into a slot (depth minimum 1mm)

MS1F25N25-13	
1x TF140714	
MS1R25N25-13	
1x TF140715	
1x	
4x MS60	
1x M6X16ISO4762	
2x FED03018	
kg	~0,165

Bestellbeispiel / Ordering example: 1x MS1F25N25-13 & 1x B14

	B13	B14	B15	B16
C	20	20	20	20
H	16	16	16	16
L	13,8	13,8	13,8	19
D	6,5	6,5	6,5	6,5
e	10	10	10	10
i	HV700	HV700	*	*
	x0,2mm	x0,2mm		
kg	~0,05	~0,05	~0,05	~0,06

* = weicher Stahl / soft steel

MS1R/F35N14-01

MS1F35N22-01

microCLAMP

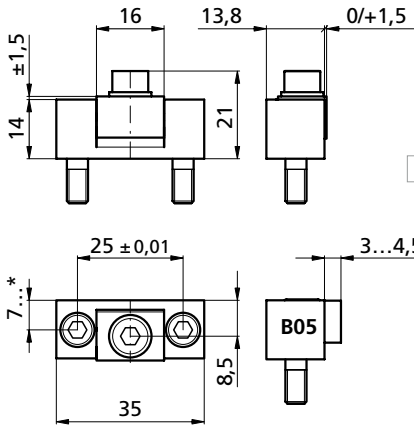

MS1F35N14-01

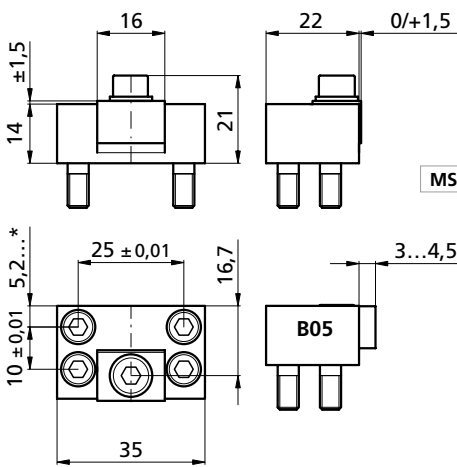
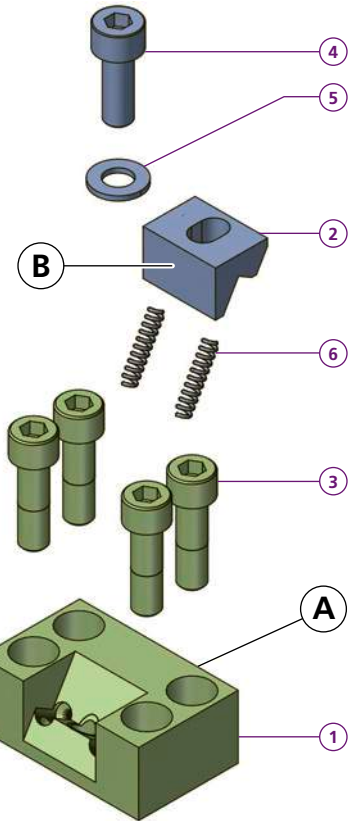
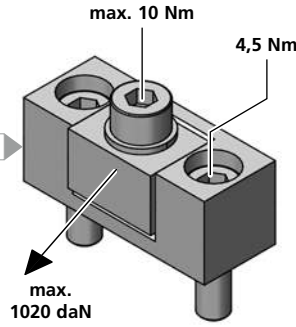

MS1F35N22-01

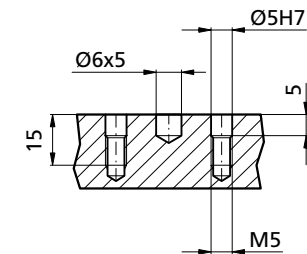
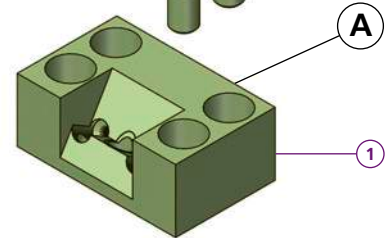
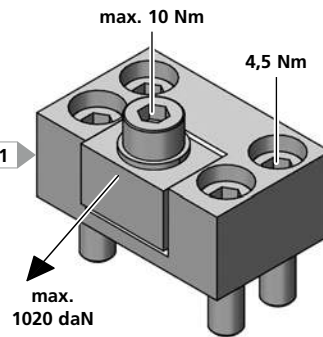

Beim Einsatz der Backe B05(R) Jaw B05(R) in use
 Nachbearbeitung am Modul, falls If a stroke of 1,1mm to 1,5mm der gesamte Backenhub (1,1mm bis is required the module must be 1,5mm) benötigt wird. machined according to this sketch.

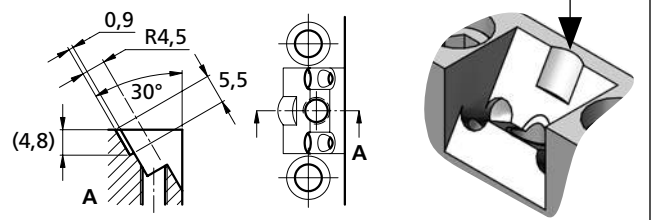

Achtung: Bei Spannkraften über 400 daN (0,4t) muss das Spannmodul in eine Nut eingelassen werden (Nuttiefe mindestens 1mm)

Remark: Using forces higher than 400 daN, clamps must be mounted into a slot (depth minimum 1mm)

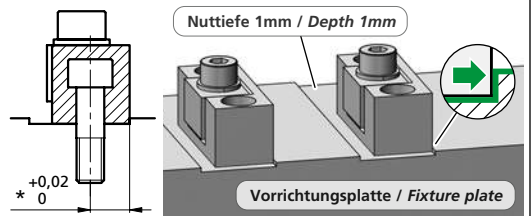

MS1F35N14-01	A
1x TF140718	
MS1R35N14-01	B
1x TK190150	
1x	
2x MS50	
1x M5X14ISO4762	
1x 5x10x1DIN125A	
2x FED02813	
kg ~0,05	
MS1F35N22-01	A
1x TF140719	
4x MS50	
kg ~0,08	

Bestellbeispiel / Ordering example: 1x MS1F35N14-01 & 1x B02

	B01	B02	B03	B04	B05	B05R
C	16	16	16	16	16	16
H	10	10	10	10	10	10
L	8	8	11	8	10	10
D	5,5	5,5	5,5	5,5	5,2	5,2
e	4	4	4	4	4	4
i	HV700	HV700	*	Messing	HV700	HV700
	x0,2mm	x0,2mm		Laiton	x0,2mm	x0,2mm
kg	~0,01	~0,01	~0,014	~0,012	~0,014	~0,014

M5X10DIN6912

Separat bestellen / Order separately

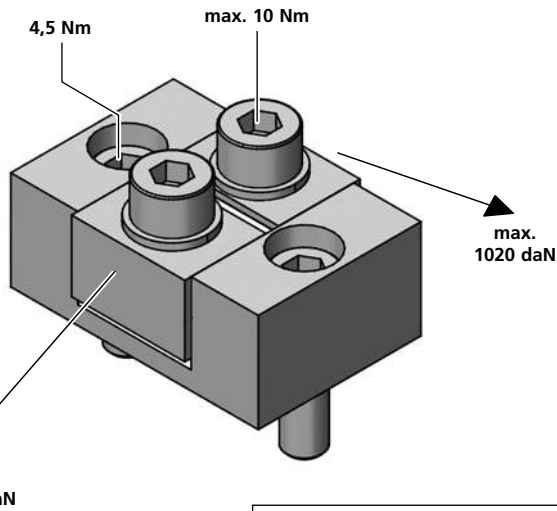
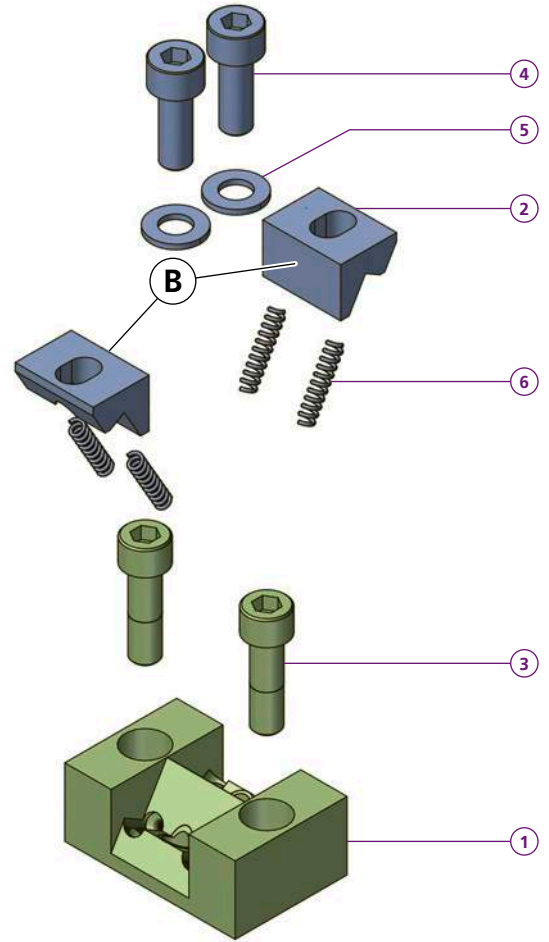
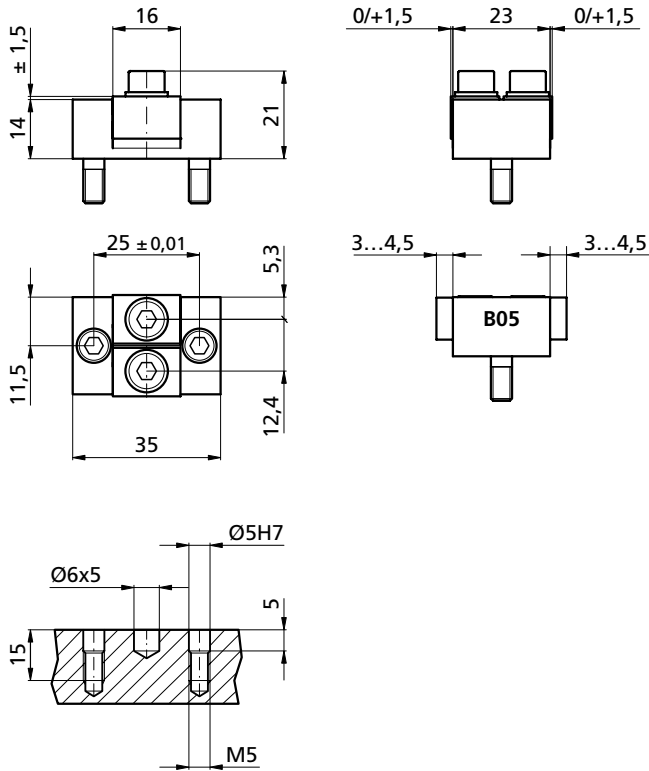

Beim Einsatz der Backe B05(R) Jaw B05(R) in use
 Nachbearbeitung am Modul, falls If a stroke of 1,1mm to 1,5mm
 der gesamte Backenhub (1,1mm bis is required the module must be
 1,5mm) benötigt wird. machined according to this sketch.

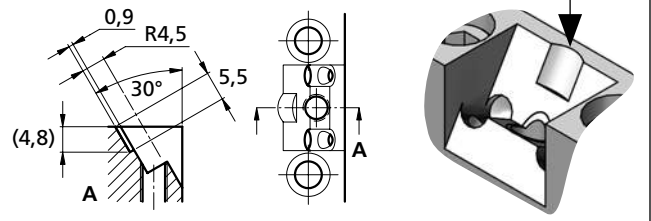

Achtung: Bei Spannkraften über 400 daN (0,4t) muss das Spannmodul in eine Nut eingelassen werden (Nuttiefe mindestens 1mm)

Remark: Using forces higher than 400 daN, clamps must be mounted into a slot (depth minimum 1mm)

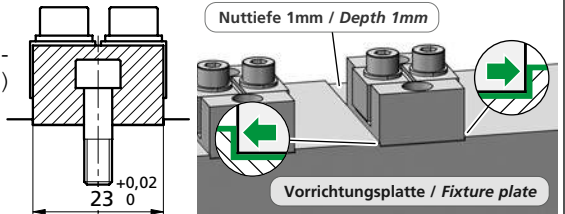

Bestellbeispiel / Ordering example: 1x MS2X35N23-01 & 2x B02

MS2X35N23-01	
1	1x TF140720
2	2x
3	2x MS50
4	2x M5X14ISO4762
5	2x 5x10x1DIN125A
6	4x FED02813
kg	~0,085

	B01	B02	B03	B04	B05	B05R
C	16	16	16	16	16	16
H	10	10	10	10	10	10
L	8	8	11	8	10	10
D	5,5	5,5	5,5	5,5	5,2	5,2
e	4	4	4	4	4	4
i	HV700	HV700	*	Messing	HV700	HV700
	x0,2mm	x0,2mm		Laiton	x0,2mm	x0,2mm
kg	~0,01	~0,01	~0,014	~0,012	~0,014	~0,014

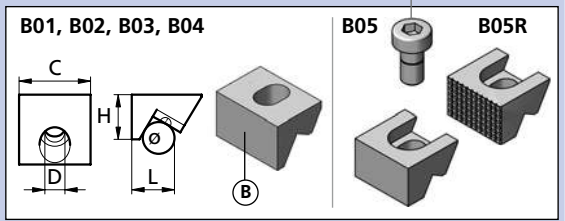

* = weicher Stahl / soft steel

Separat bestellen / Order separately

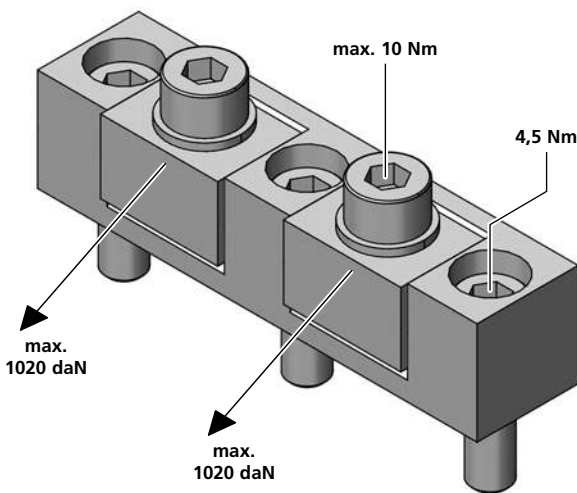
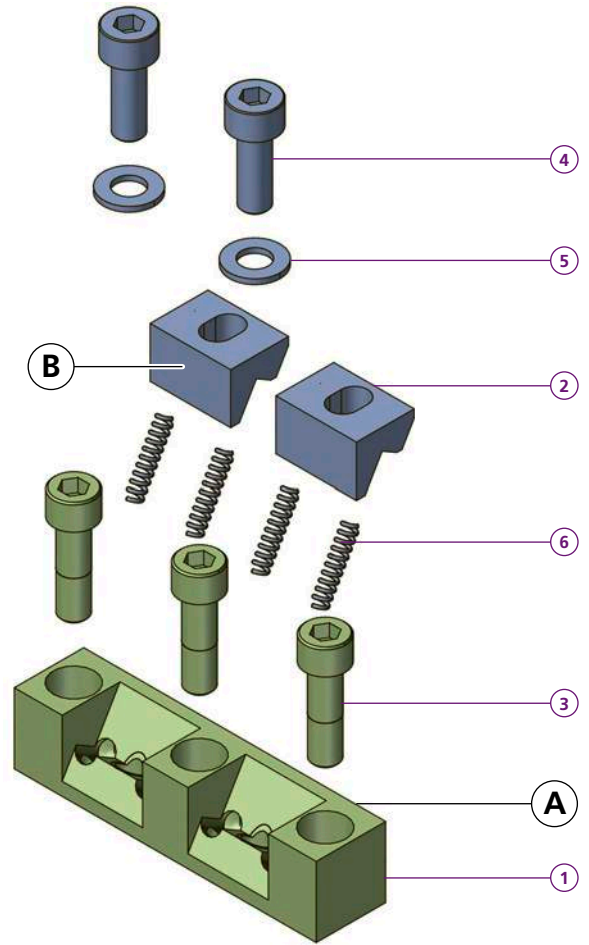
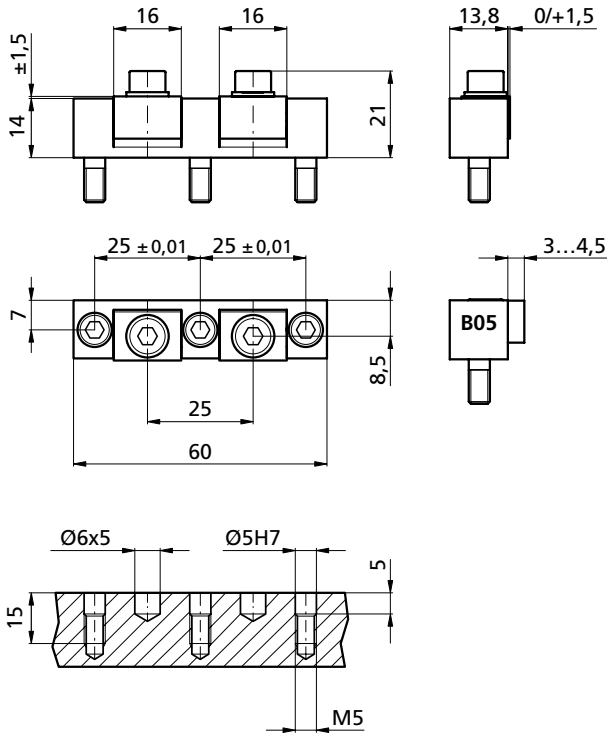

Beim Einsatz der Backe B05(R) Jaw B05(R) in use
 Nachbearbeitung am Modul, falls If a stroke of 1,1mm to 1,5mm
 der gesamte Backenhub (1,1mm bis is required the module must be
 1,5mm) benötigt wird. machined according to this sketch.

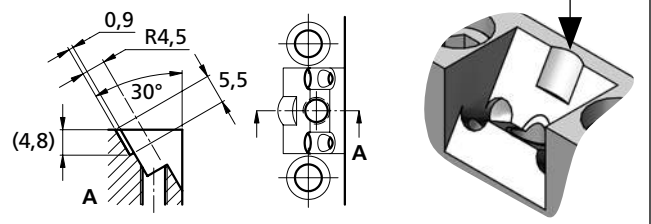

Achtung: Bei Spannkraften über 400 daN (0,4t) muss das Spannmodul in eine Nut eingelassen werden (Nuttiefe mindestens 1mm)

Remark: Using forces higher than 400 daN, clamps must be mounted into a slot (depth minimum 1mm)

Nuttiefe 1mm / Depth 1mm

Vorrichtungplatte / Fixture plate

Bestellbeispiel / Ordering example: 1x MS2F60N14-01 & 2x B02

MS2F60N14-01		B01	B02	B03	B04	B05	B05R	MSX10DIN6912	
1	1x TF140721								
2	2x								
3	3x MS50								
4	2x M5X14ISO4762								
5	2x 5x10x1DIN125A								
6	4x FED02813								
		C							
		H							
		L							
		D							
		e							
		i							
kg	~0,09								
		kg							

B01, B02, B03, B04

B05 B05R

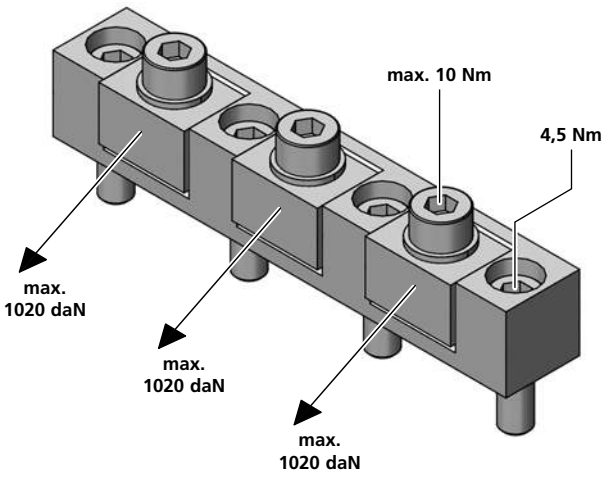
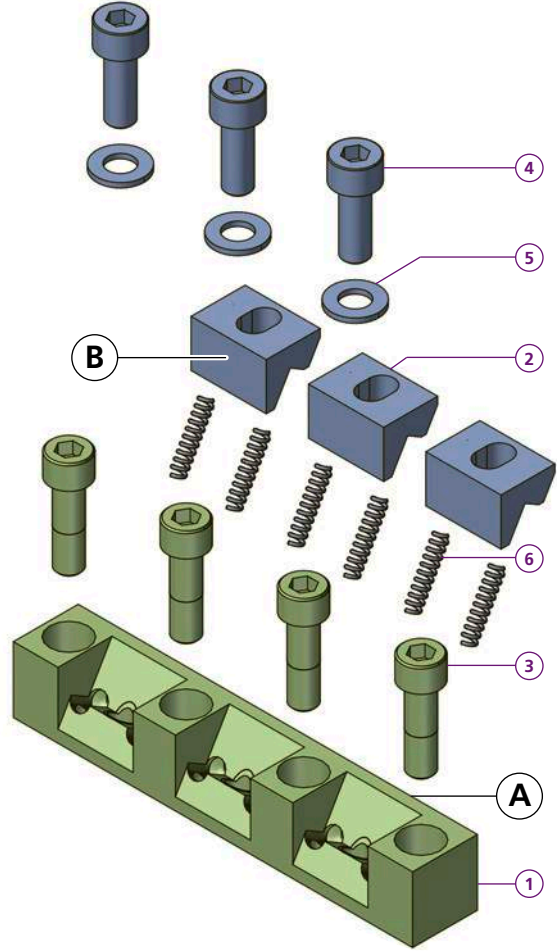
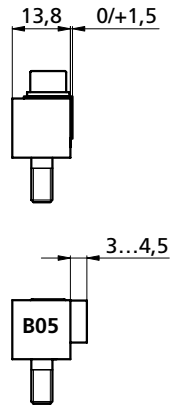
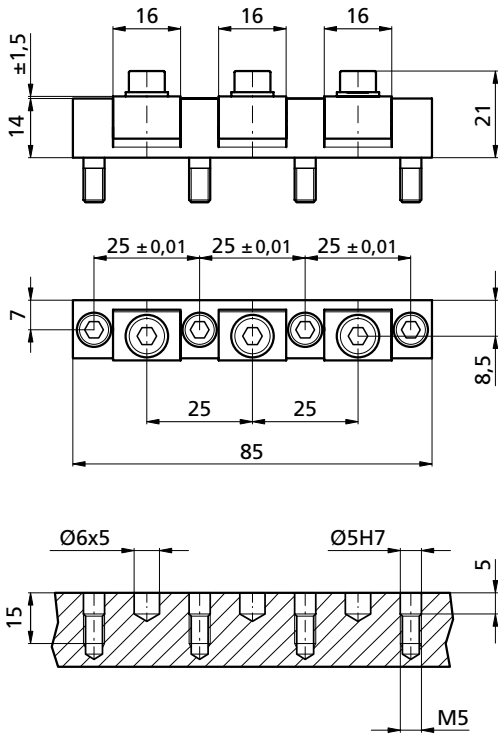

Beim Einsatz der Backe B05(R) Jaw B05(R) in use
 Nachbearbeitung am Modul, falls If a stroke of 1,1mm to 1,5mm
 der gesamte Backenhub (1,1mm bis is required the module must be
 1,5mm) benötigt wird. machined according to this sketch.

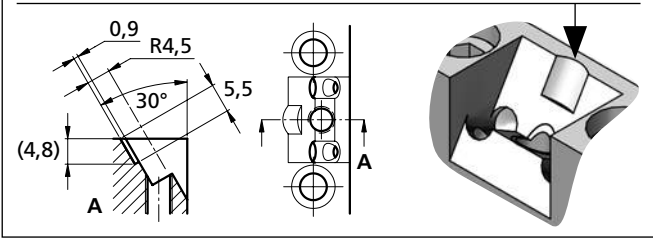

Achtung: Bei Spannkraften über 400 daN (0,4t) muss das Spannmodul in eine Nut eingelassen werden (Nuttiefe mindestens 1mm)
Remark: Using forces higher than 400 daN, clamps must be mounted into a slot (depth minimum 1mm)

Bestellbeispiel / Ordering example: 1x MS3F85N14-01 & 3x B02

MS3F85N14-01	B01	B02	B03	B04	B05	B05R
1x TH160579	16	16	16	16	16	16
3x	10	10	10	10	10	10
4x MS50	8	8	11	8	10	10
3x M5X14ISO4762	5,5	5,5	5,5	5,5	5,2	5,2
3x 5x10x1DIN125A	4	4	4	4	4	4
6x FED02813	HV700	HV700	*	Messing	HV700	HV700
	x0,2mm	x0,2mm		Laiton	x0,2mm	x0,2mm
kg ~0,125	kg ~0,01	kg ~0,01	kg ~0,014	kg ~0,012	kg ~0,014	kg ~0,014

M5X10DIN6912

* = weicher Stahl / soft steel

Separat bestellen / Order separately

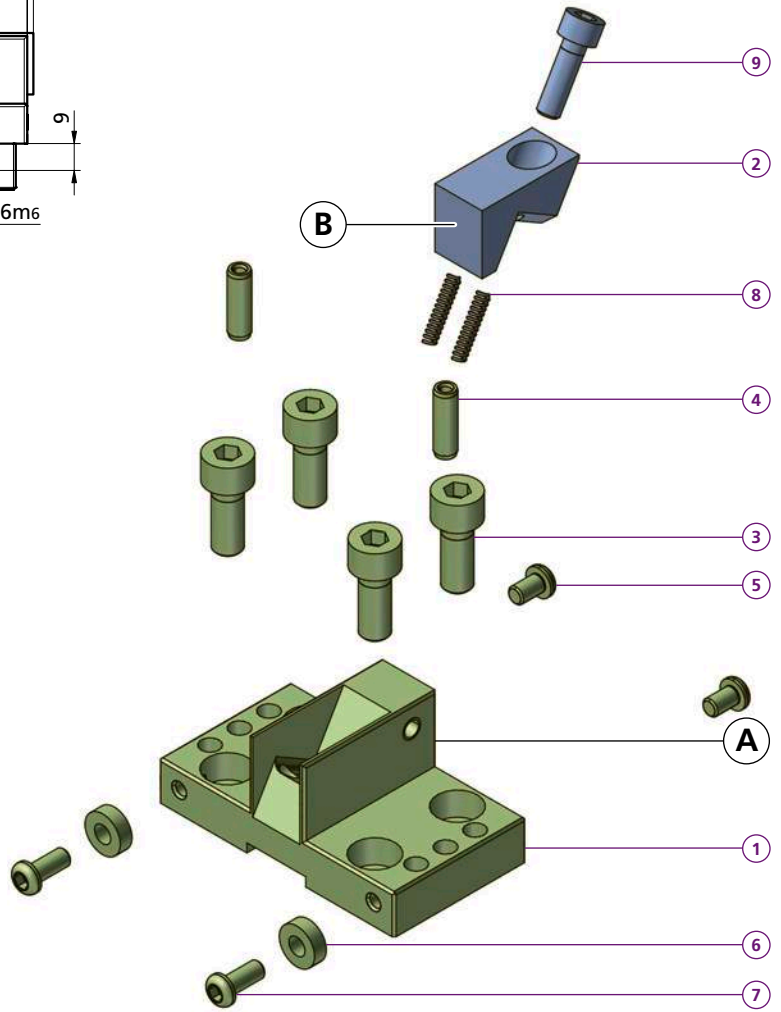
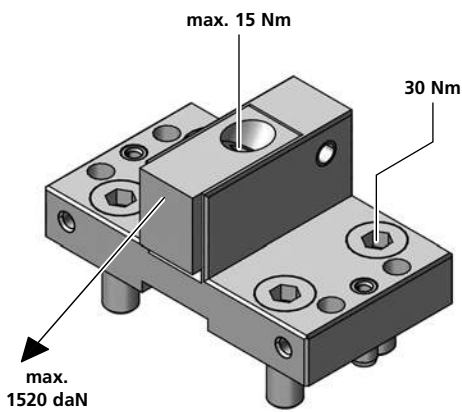
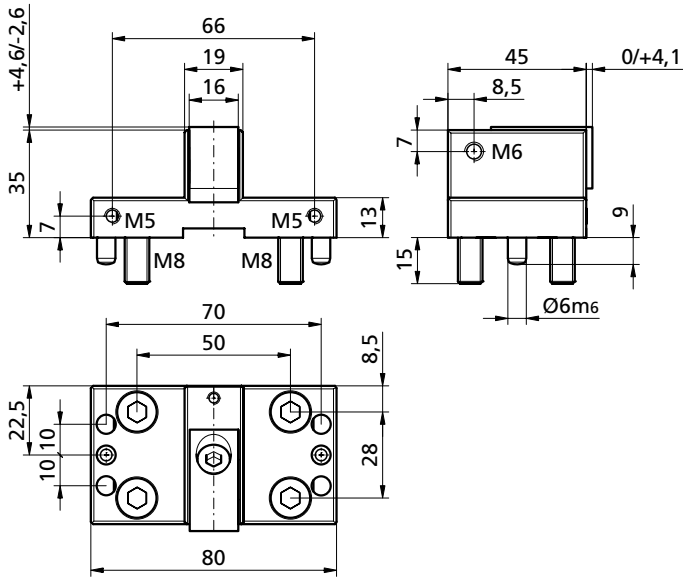

	A
VS1F19N35-20	
1x TF150029	
VS1R19N35-20	
1x TF140723	
1x	
4x M8X20ISO4762	
2x CCBO0802	
2x M5X8ISO7380	
2x CCD004	
2x M5X12ISO7380	
2x FED0418	
1x M6X20ISO4762	
kg ~0,505	

B Bestellbeispiel / Ordering example: 1x VS1R19N35-20 & 1x B21

	B20	B21	B22
C	16	16	16
H	20	20	20
L	19	19	19
D	6,5	6,5	6,5
e	12	12	12
i	HV700 x0,2mm	HV700 x0,2mm	*
kg	~0,011	~0,011	~0,011

B20, B21, B22

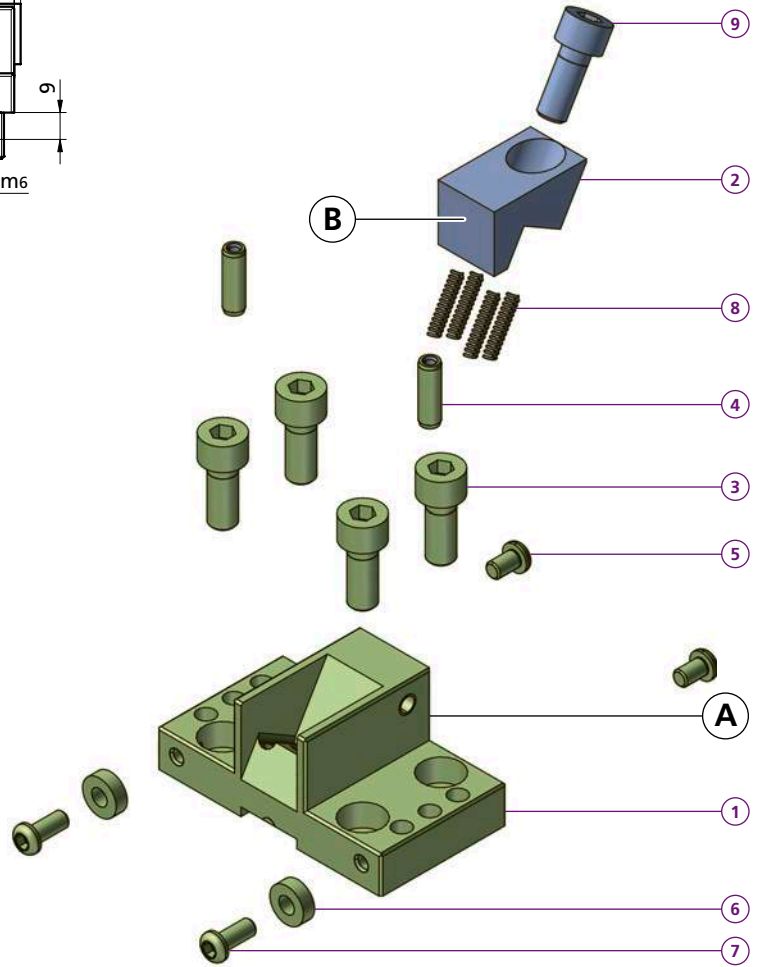
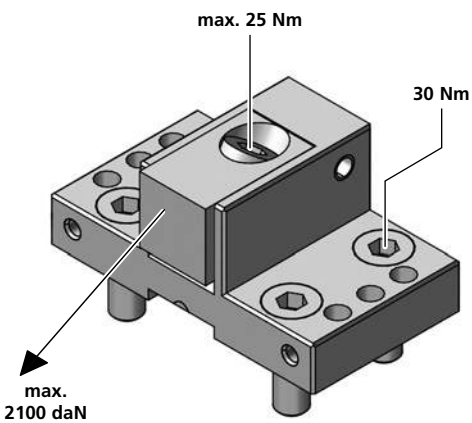
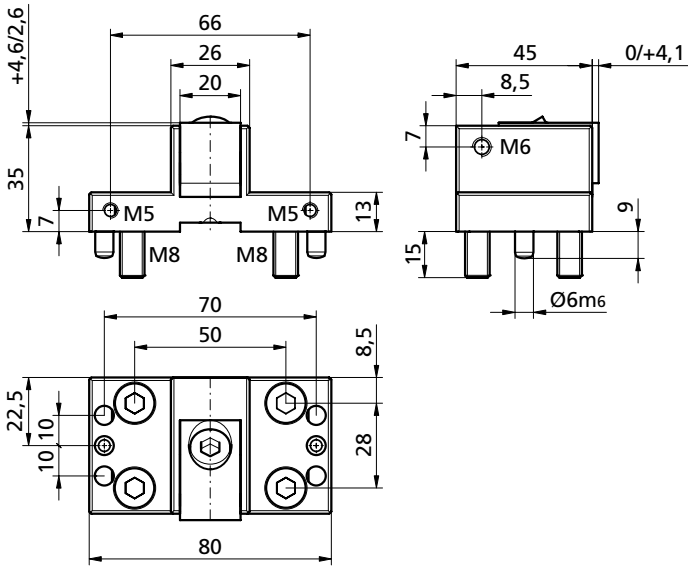

VS1R26N35-26	
1	1x TF140725
2	1x
3	4x M8X20ISO4762
4	2x CCBO0802
5	2x M5X8ISO7380
6	2x CCD004
7	2x M5X12ISO7380
8	4x FED0418
9	1x M8X20ISO4762
kg	~0,55

Bestellbeispiel / Ordering example: 1x VS1R26N35-26 & 1x B27

	B26	B27	B28
C	20	20	20
H	20	20	20
L	19	19	19
D	9	9	9
ø	12	12	12
i	HV700	HV700	*
	x0,2mm	x0,2mm	
kg	~0,064	~0,064	~0,064

B26, B27, B28

* = weicher Stahl / soft steel

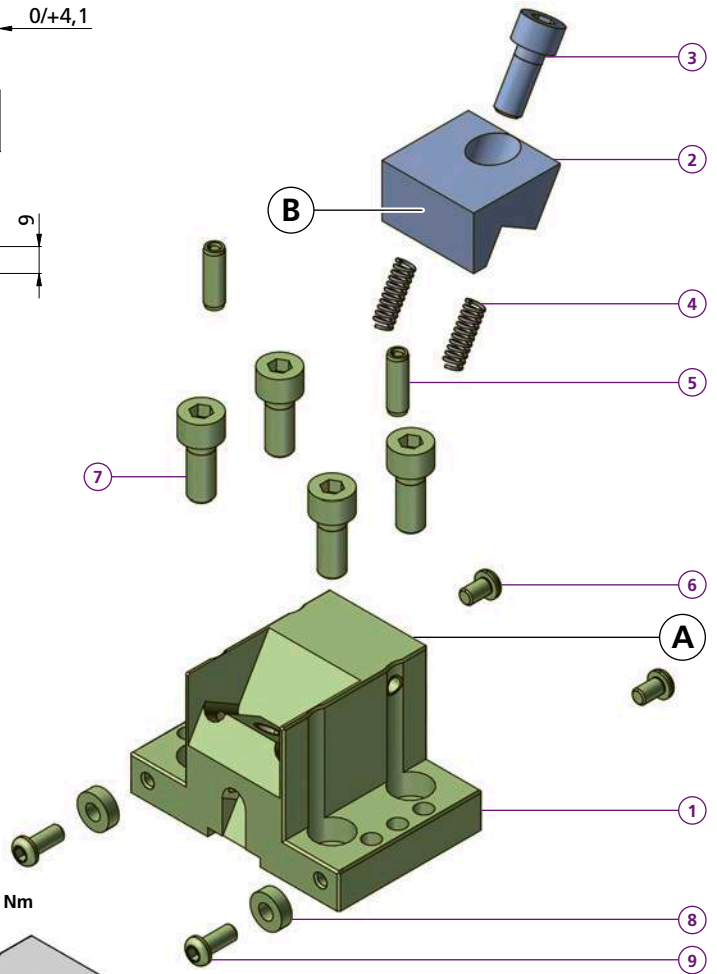
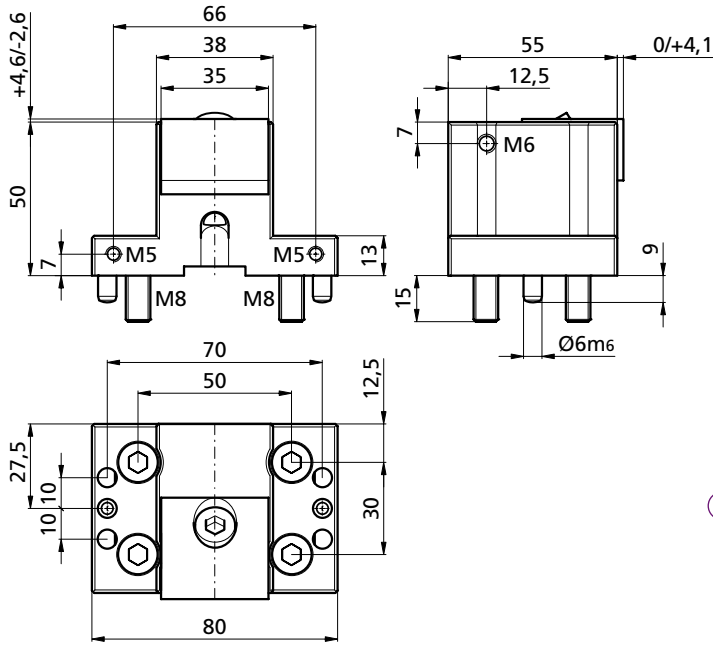

VS1R38N50-60

1	1x	TF140726
2	1x	
3	1x	M8X20ISO4762
4	2x	FED0618
5	2x	CCBO0802
6	2x	M5X8ISO7380
7	4x	M8X20ISO4762
8	2x	CCD004
9	2x	M5X12ISO7380
kg		~1,01

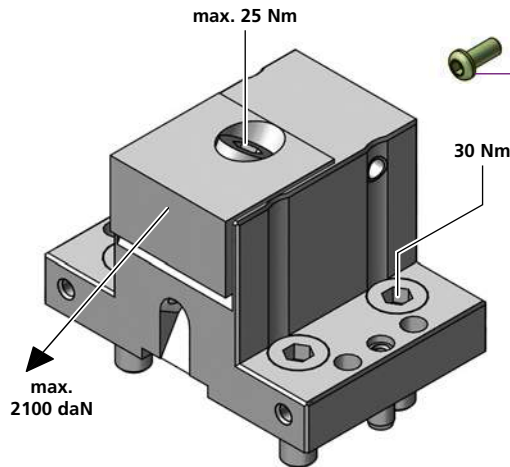

Bestellbeispiel / Ordering example: 1x VS1R38N50-60 & 1x B61

	B58	B60	B61	B62	B62HM	B65	B66	B67	B68	B69	B77	B79F	B79R
C	35	35	35	35	35	35	35	35	35	35	35	35	35
H	20	20	20	20	20	20	20	20	20	25	20	20	20
L	26	19	19	19	19	19	19	24	26	22	22	25	25
D	9	9	9	9	9	9	9	9	9	9	9	9	9
ø	12	12	12	12	12	12	12	12	12	12	12	12	12
i	ALU	56HRC	56HRC	*	HM	HV700 x0,2mm	HV700 x0,2mm	HV700 x0,2mm	*	*	56HRC	HV700 x0,2mm	HV700 x0,2mm
kg	~0,07	~0,12	~0,12	~0,12	~0,12	~0,12	~0,12	~0,14	~0,15	~0,15	~0,12	~0,18	~0,18

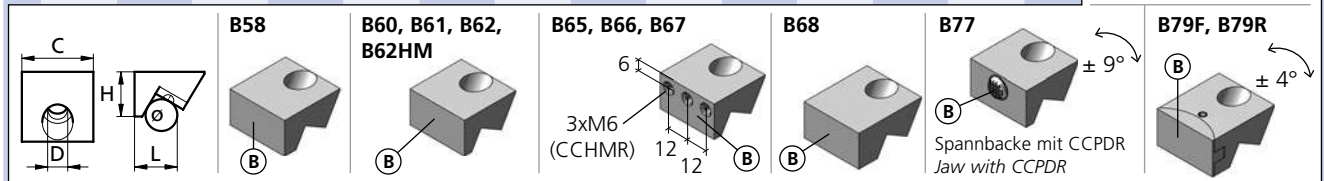
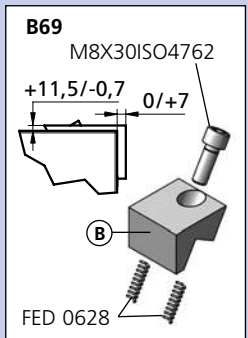

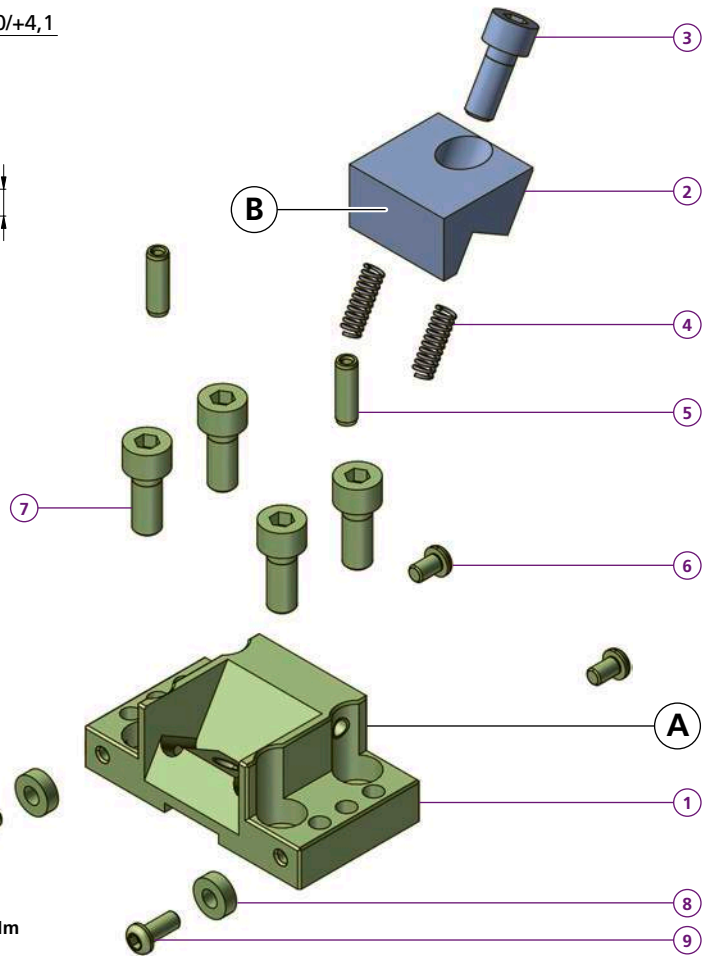
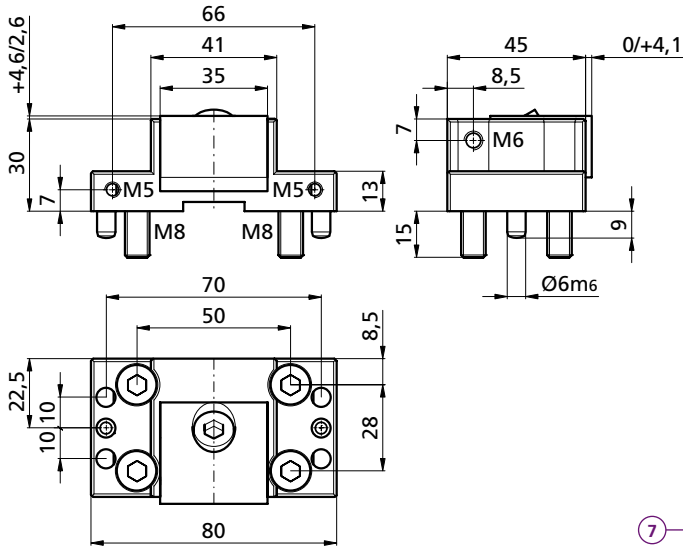

- VS1F41N30-60**
- 1x TF140729
- VS1R41N30-60**
- 1x TF140730
- 1x
- 1x M8X20ISO4762
- 2x FED0618
- 2x CCBO0802
- 2x M5X8ISO7380
- 4x M8X20ISO4762
- 2x CCD004
- 2x M5X12ISO7380
- kg ~0,58

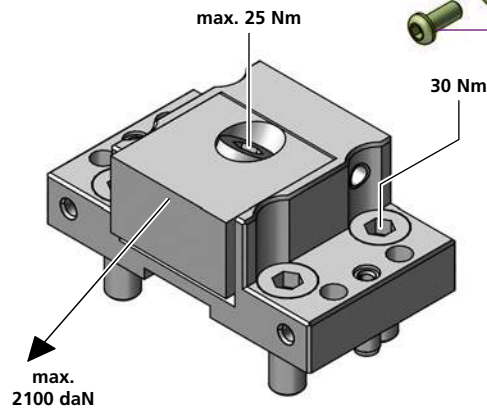

Bestellbeispiel / Ordering example: 1x VS1R41N30-60 & 1x B61

	B58	B60	B61	B62	B62HM	B65	B66	B67	B68	B77	B79F	B79R
C	35	35	35	35	35	35	35	35	35	35	35	35
H	20	20	20	20	20	20	20	20	20	20	20	20
L	26	19	19	19	19	19	19	24	26	22	25	25
D	9	9	9	9	9	9	9	9	9	9	9	9
ø	12	12	12	12	12	12	12	12	12	12	12	12
i	ALU	56HRC	56HRC	*	HM	HV700	HV700	HV700	*	56HRC	HV700	HV700
kg	~0,07	~0,12	~0,12	~0,12	~0,12	~0,12	~0,12	~0,14	~0,15	~0,12	~0,18	~0,18

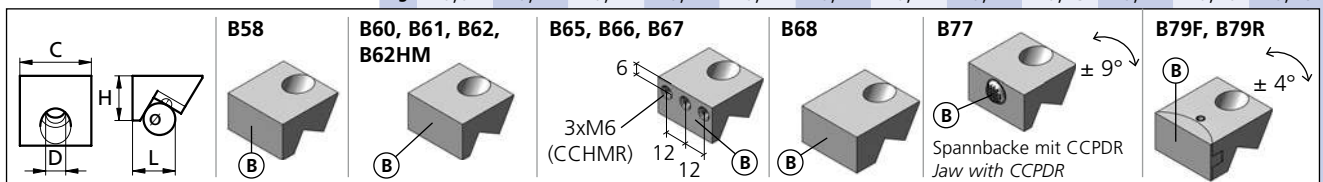

* = weicher Stahl / soft steel

HM = Hartmetallbeschichtet / Carbide coated

ALU = ENAW-7022

VS1R/F80N30-36

VS1R80N50-36

microCLAMP

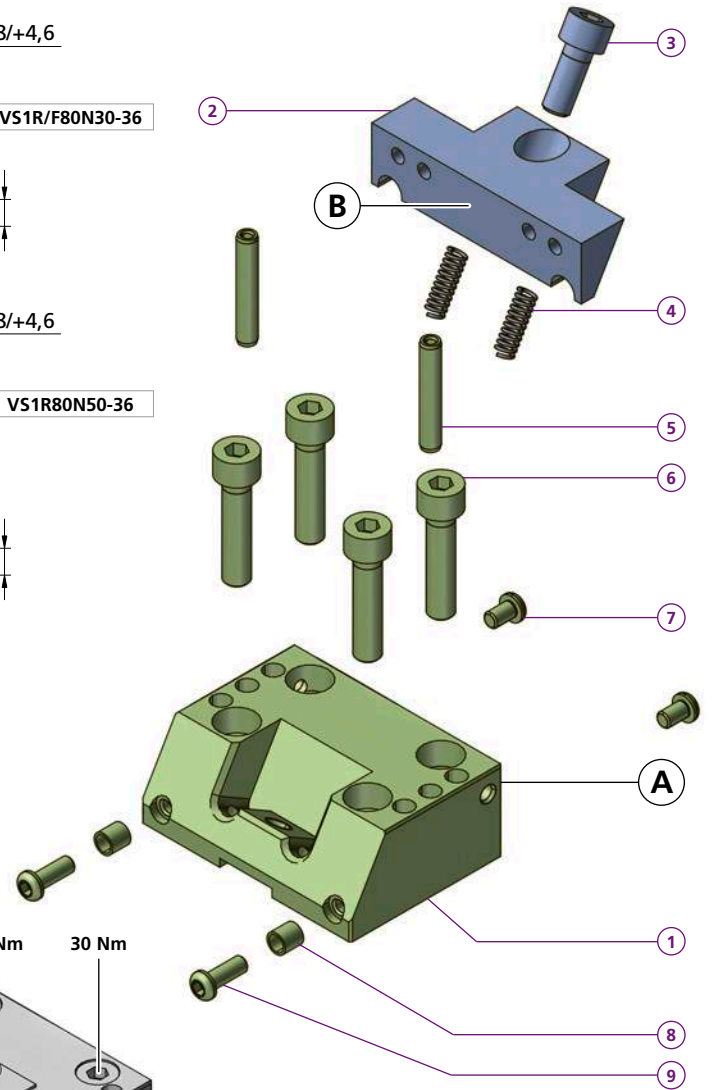
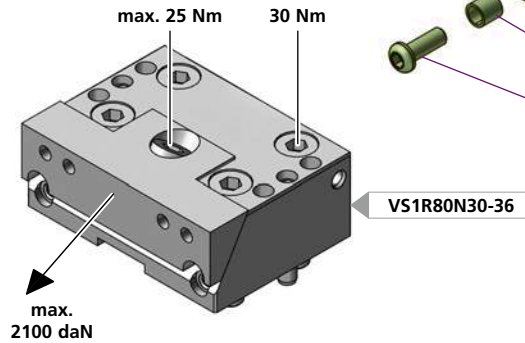
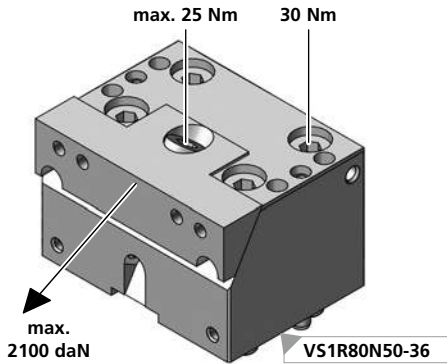
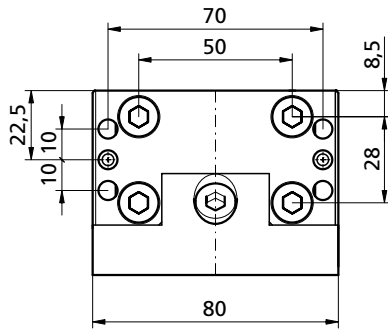
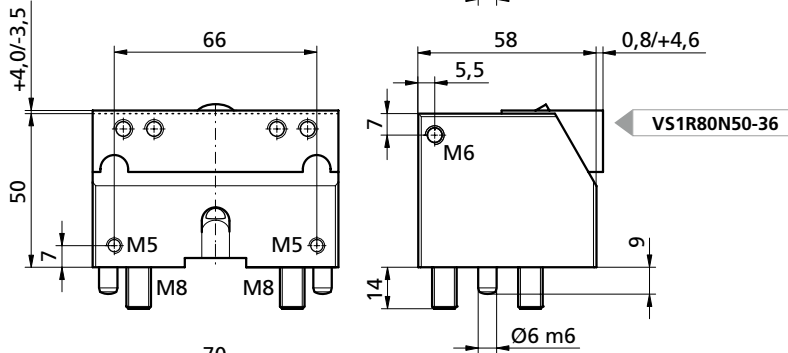
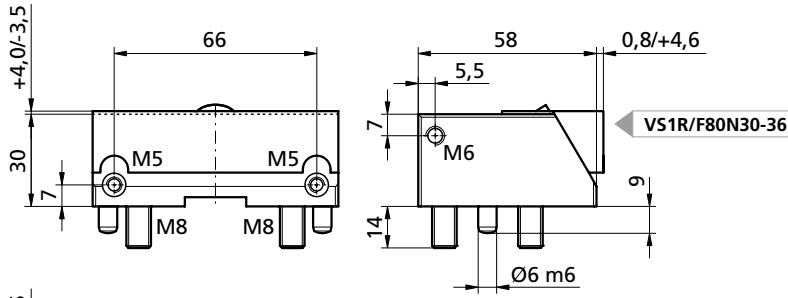

VS1F80N30-36	VS1R80N30-36	VS1R80N50-36
1x TF140733	1x TF140734	1x TF140742
1x M8X20ISO4762	1x M8X35ISO4762	2x CCBO0803
4x FED0618	2x M5X8ISO4762	4x M8X55ISO4762
2x CCBO0801	2x CCD007	2x M5X12ISO7380
4x M8X35ISO4762	2x M5X16ISO7380	
kg ~1,2	kg ~1,9	

Bestellbeispiel / Ordering example: 1x VS1R80N30-36 & 1x B37

	B36	B37	B38
C	80	80	80
H	20	20	20
L	19	19	19
D	9	9	9
ø	12	12	12
i	HV700 x0,2mm	HV700 x0,2mm	*
kg	~0,18	~0,18	~0,18

B36, B37, B38

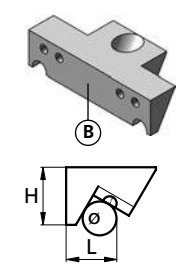

Separat bestellen / Order separately

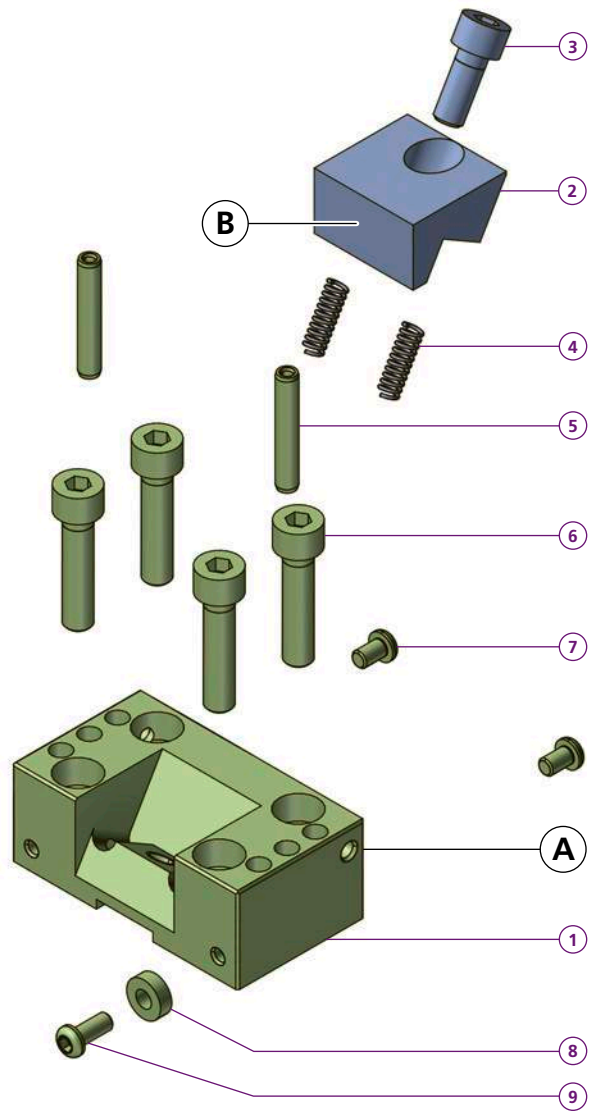
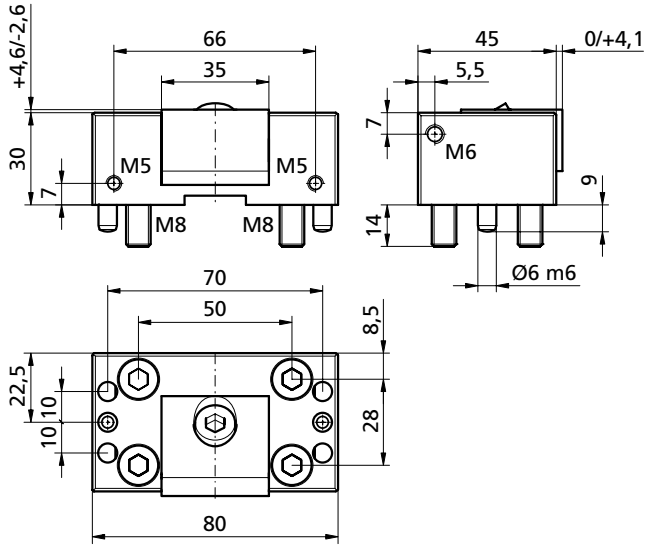

- VS1F80N30-60**
- 1 1x TF140735
- VS1R80N30-60**
- 1 1x TF140736
 - 2 1x
 - 3 1x M8X20ISO4762
 - 4 2x FED0618
 - 5 2x CCBO0801
 - 6 4x M8X35ISO4762
 - 7 2x M5X8ISO7380
 - 8 2x CCD004
 - 9 2x M5X12ISO7380
- kg ~0,74

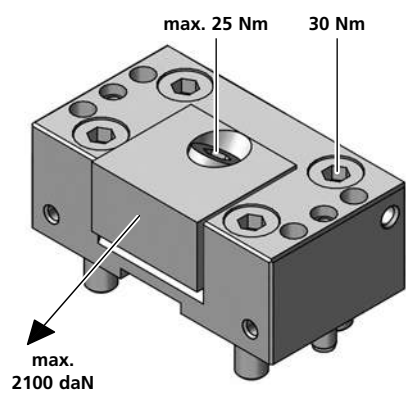

Bestellbeispiel / Ordering example: 1x VS1F80N30-60 & 1x B61

	B58	B60	B61	B62	B62HM	B65	B66	B67	B68	B77	B79F	B79R
C	35	35	35	35	35	35	35	35	35	35	35	35
H	20	20	20	20	20	20	20	20	20	20	20	20
L	26	19	19	19	19	19	19	24	26	22	25	25
D	9	9	9	9	9	9	9	9	9	9	9	9
ø	12	12	12	12	12	12	12	12	12	12	12	12
i	ALU	56HRC	56HRC	*	HM	HV700 x0,2mm	HV700 x0,2mm	HV700 x0,2mm	*	56HRC	HV700 x0,2mm	HV700 x0,2mm
kg	~0,07	~0,12	~0,12	~0,12	~0,12	~0,12	~0,12	~0,14	~0,15	~0,12	~0,18	~0,18

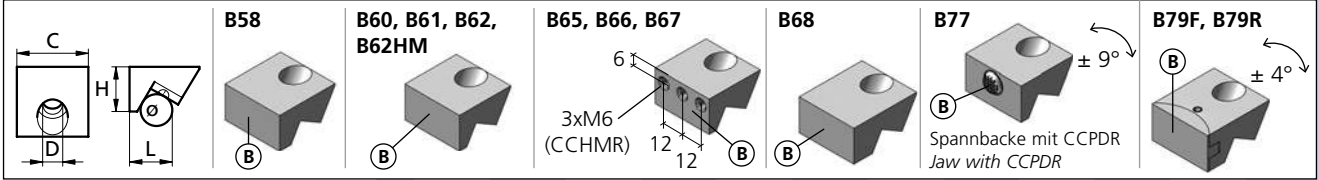

* = weicher Stahl / soft steel HM = Hartmetallbeschichtet / Carbide coated ALU = ENAW-7022

Separat bestellen / Order separately

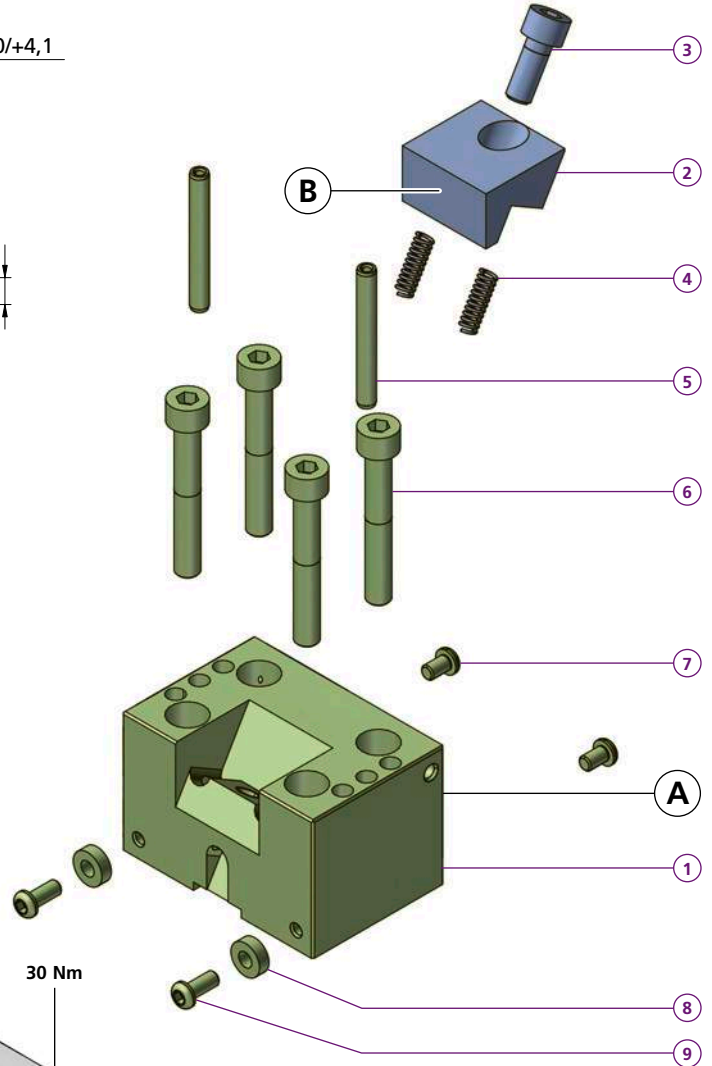
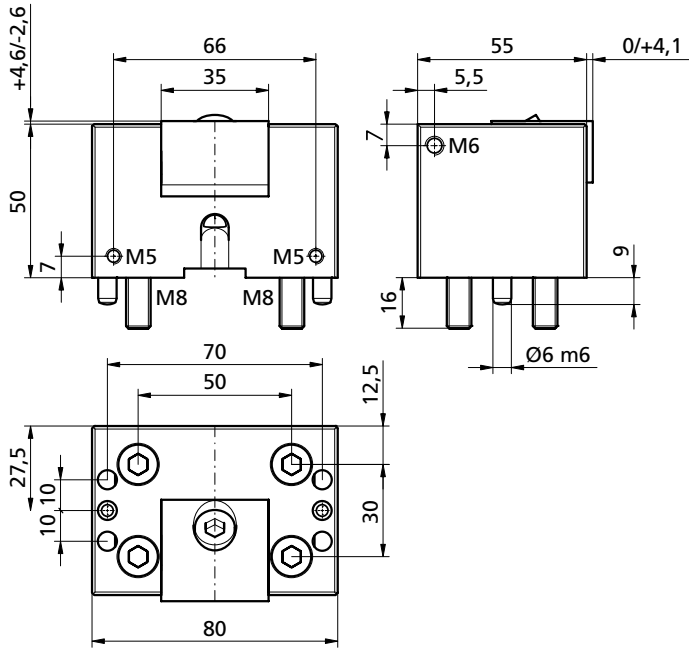

VS1R80N50-60

1	1x	TF140737
2	1x	
3	1x	M8X20ISO4762
4	2x	FED0618
5	2x	CCBO0803
6	4x	M8X55ISO4762
7	2x	M5X8ISO7380
8	2x	CCD004
9	2x	M5X12ISO7380
kg		~1,6

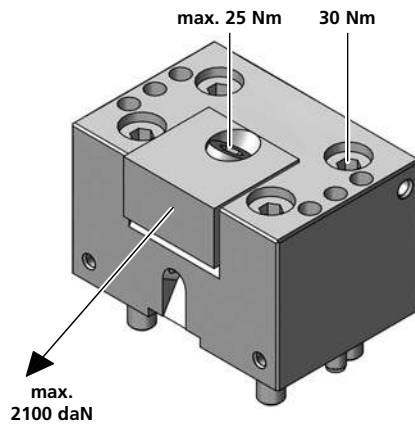

Bestellbeispiel / Ordering example: 1xVS1R80N50-60 & 1x B61

	B58	B60	B61	B62	B62HM	B65	B66	B67	B68	B69	B77	B79F	B79R
C	35	35	35	35	35	35	35	35	35	35	35	35	35
H	20	20	20	20	20	20	20	20	20	25	20	20	20
L	26	19	19	19	19	19	19	24	26	22	22	25	25
D	9	9	9	9	9	9	9	9	9	9	9	9	9
o	12	12	12	12	12	12	12	12	12	12	12	12	12
i	ALU	56HRC	56HRC	*	HM	HV700 x0,2mm	HV700 x0,2mm	HV700 x0,2mm	*	*	56HRC	HV700 x0,2mm	HV700 x0,2mm
kg	~0,07	~0,12	~0,12	~0,12	~0,12	~0,12	~0,12	~0,14	~0,15	~0,15	~0,12	~0,18	~0,18

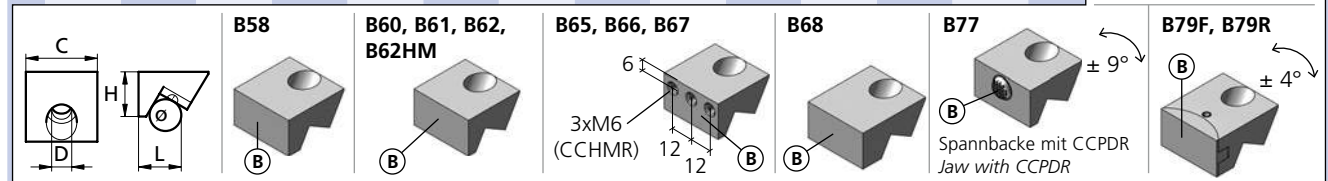
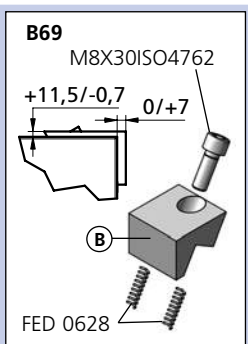

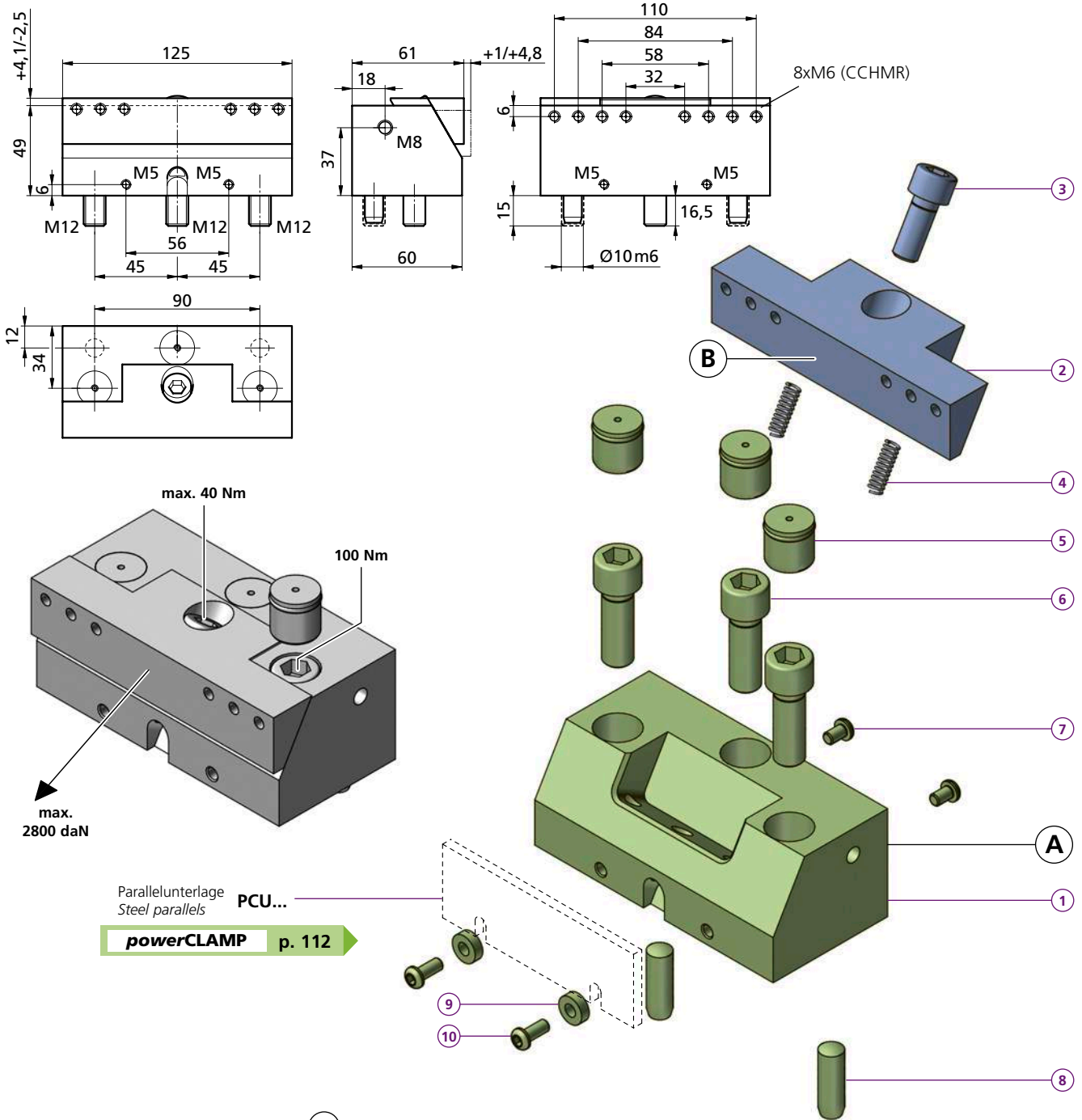

Parallelunterlage
Steel parallels
PCU...
powerCLAMP p. 112

Bestellbeispiel / Ordering example: 1x VS1R125N49-95 & 1x B96

	B95	B96	B97	B98	B99
VS1F125N49-95					
1x TF140738					
VS1R125N49-95					
1x TF140739					
1x					
1x M10X25ISO4762					
2x FED0618					
3x PCPF16L18Alu					
3x M12X35ISO4762					
3x M5X8ISO7380					
2x 10m6x30 DIN6325					
2x CCD004					
2x M5X12ISO7380					
kg	~2,6				

	B95	B96	B97	B98	B99
C	125	125	125	125	125
H	25	25	25	25	25
L	23	23	23	30	23
D	11	11	11	11	11
e	15	15	15	15	15
i	HV700 x0,2mm	HV700 x0,2mm	*	*	HV700 x0,2mm
kg	~0,45	~0,45	~0,45	~0,63	~0,45

	B95, B96, B97, B99	B98
6xM6 (CCHMR)		
110		
84		
58		
6		

* = weicher Stahl / soft steel

Separat bestellen / Order separately

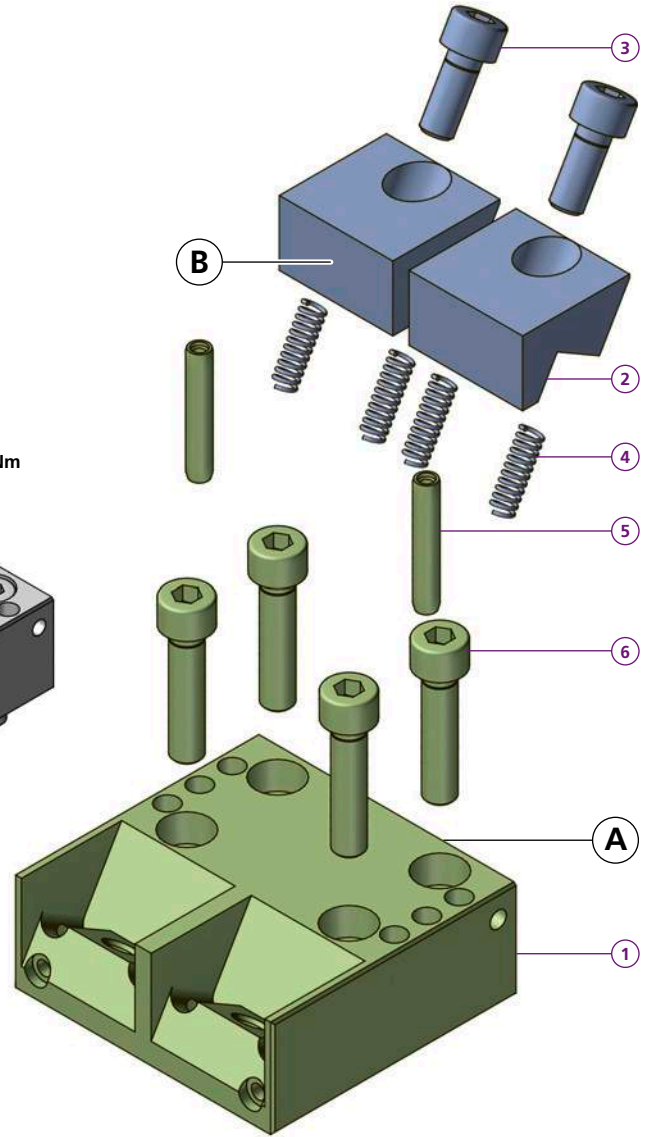
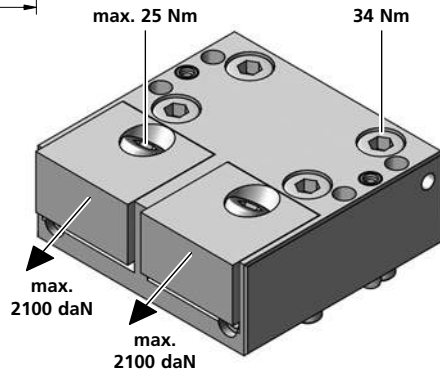
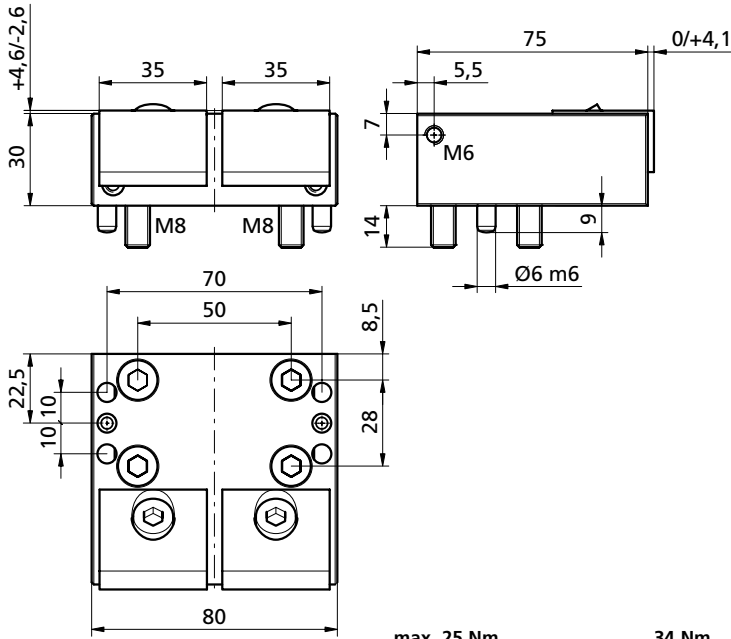

VS2R80N30-60	
1	1x TF140740
2	2x
3	2x M8X20ISO4762
4	4x FED0618
5	2x CCBO0801
6	4x M8X35ISO4762
kg	~1,3

Bestellbeispiel / Ordering example: 1x VS2R80N30-60 & 2x B61

	B58	B60	B61	B62	B62HM	B65	B66	B67	B68	B77	B79F	B79R
C	35	35	35	35	35	35	35	35	35	35	35	35
H	20	20	20	20	20	20	20	20	20	20	20	20
L	26	19	19	19	19	19	19	24	26	22	25	25
D	9	9	9	9	9	9	9	9	9	9	9	9
o	12	12	12	12	12	12	12	12	12	12	12	12
i	ALU	56HRC	56HRC	*	HM	HV700	HV700	HV700	*	56HRC	HV700	HV700
		x0,2mm	x0,2mm			x0,2mm	x0,2mm	x0,2mm			x0,2mm	x0,2mm
kg	~0,07	~0,12	~0,12	~0,12	~0,12	~0,12	~0,12	~0,14	~0,15	~0,12	~0,18	~0,18

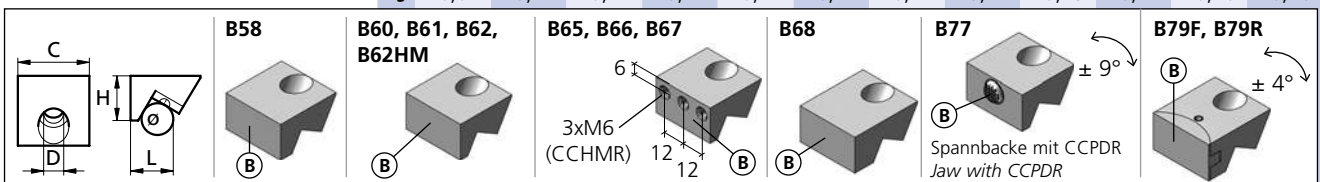

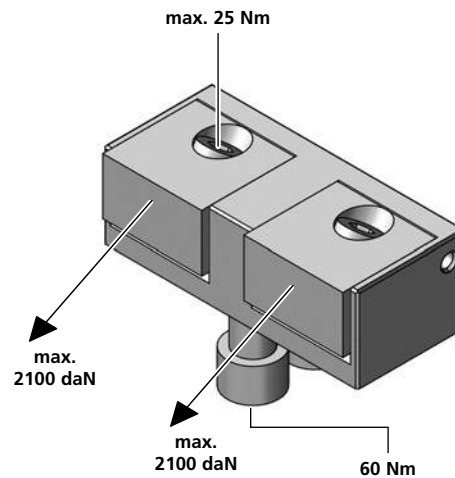
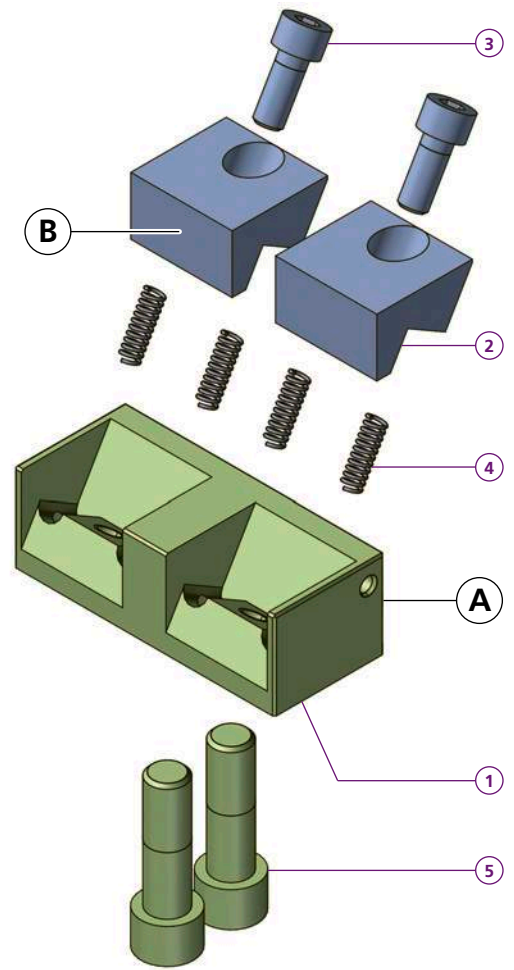
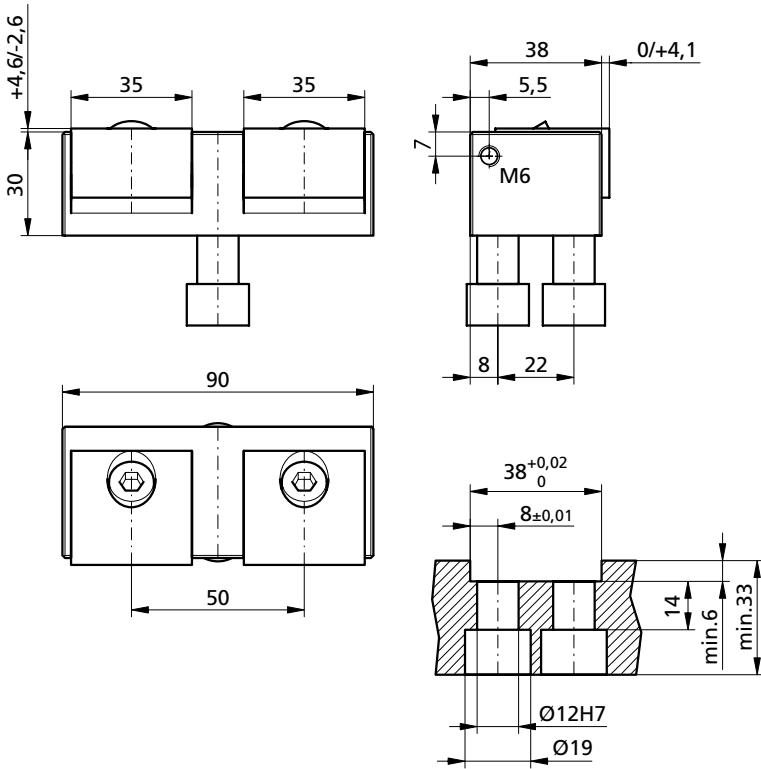

VS2F90N30-60	
1	1x TF140741
2	2x
3	2x M8X20ISO4762
4	4x FED0618
5	2x TWPAS1232
kg	~0,85

Bestellbeispiel / Ordering example: 1x VS2F90N30-60 & 2x B61

	B58	B60	B61	B62	B62HM	B65	B66	B67	B68	B77	B79F	B79R
C	35	35	35	35	35	35	35	35	35	35	35	35
H	20	20	20	20	20	20	20	20	20	20	20	20
L	26	19	19	19	19	19	19	24	26	22	25	25
D	9	9	9	9	9	9	9	9	9	9	9	9
ø	12	12	12	12	12	12	12	12	12	12	12	12
i	ALU	56HRC	56HRC	*	HM	HV700 x0,2mm	HV700 x0,2mm	HV700 x0,2mm	*	56HRC	HV700 x0,2mm	HV700 x0,2mm
kg	~0,07	~0,12	~0,12	~0,12	~0,12	~0,12	~0,12	~0,14	~0,15	~0,12	~0,18	~0,18

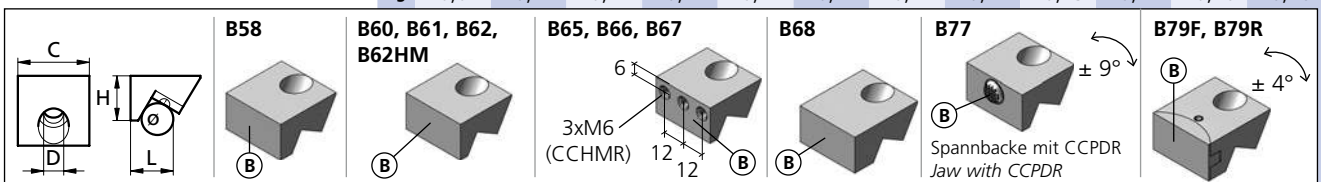

* = weicher Stahl / soft steel

HM = Hartmetallbeschichtet / Carbide coated

ALU = ENAW-7022

MS1R/F35L14-152

MS1R/F35L14-150 (Alte Version / Old Version)

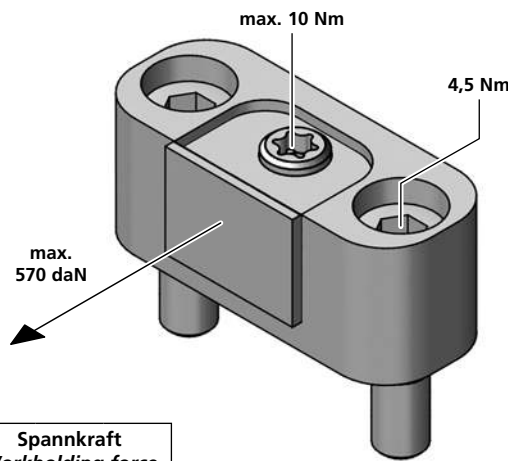
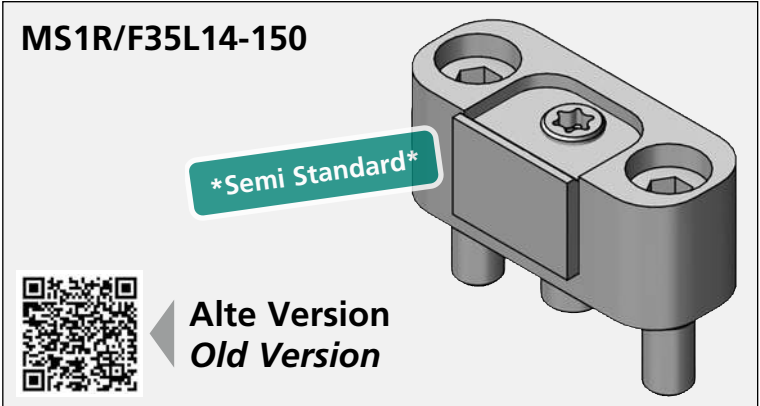
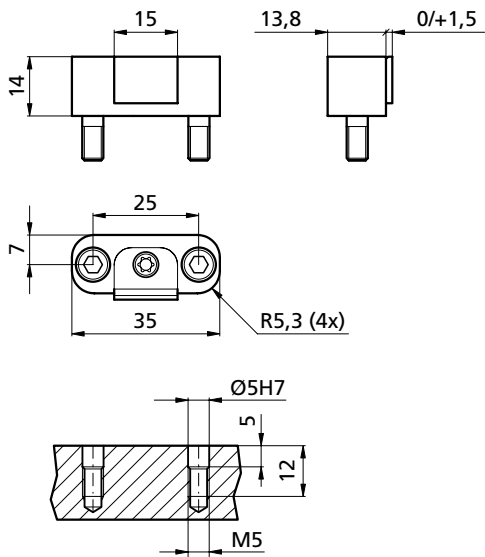

Drehmoment Torque		Spannkraft Workholding force		
Nm	(lb-ft)	~daN	~(lb)	~t
7	5,18	= 390	860	0,39
8	5,92	= 450	990	0,45
9	6,66	= 510	1120	0,51
10	7,4	= 570	1250	0,57

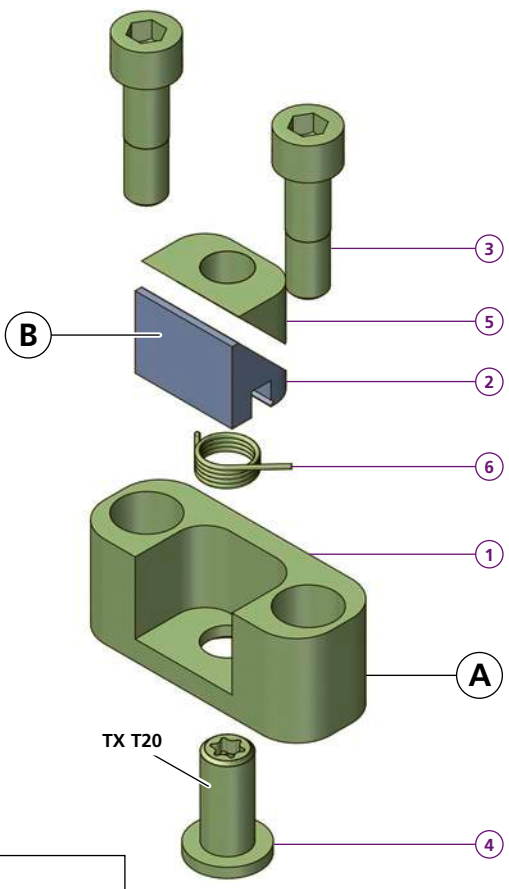

Achtung: Bei Spannkraften über 400 daN (0,4t) muss das Spannmodul in eine Nut eingelassen werden (Nuttiefe mindestens 1mm)

Remark: Using forces higher than 400 daN, clamps must be mounted into a slot (depth minimum 1mm)

Vorrichtungplatte / Fixture plate

- MS1F35L14-152**
- 1x TK181266
- MS1R35L14-152**
- 1x TF190596
- 1x _____
- 2x MS50
- 1x GEWST6L14
- 1x MSK15W45
- 1x SFED6W90
- kg ~0,03

Bestellbeispiel / Ordering example: 1x MS1F35L14-152 & 1x B151

	B150	B151
C	15	15
H	11	11
L	40,3	40,3
e	40	40
i	HV700 x0,2mm	HV700 x0,2mm
kg	~0,004	~0,004

Separat bestellen / Order separately

VS1R26L35-31

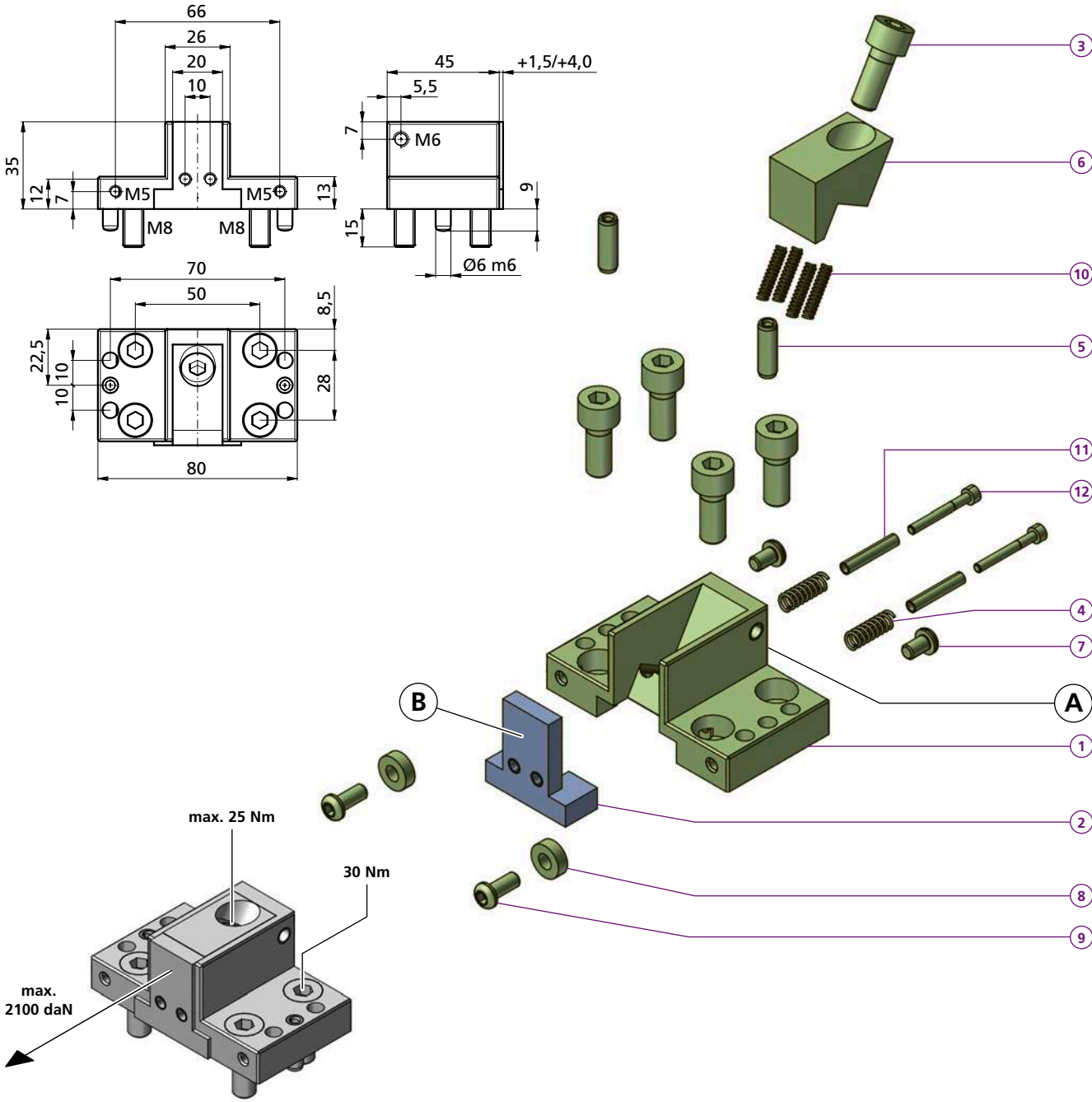

VS1R26L35-31	
1	1x TF140724
2	1x
3	5x M8X20ISO4762
4	2x FED0618
5	2x CCBO0802
6	1x B30
7	2x M5X8ISO7380
8	2x CCD004
9	2x M5X12ISO7380
10	4x FED0418
11	2x CCD422
12	2x M3X25ISO4762
kg	~0,55

Bestellbeispiel / Ordering example: 1x VS1R26L35-31 & 1x B32

	B31	B32	B33
C	20	20	20
H	35	35	35
L	6	6	6
D	-	-	-
e	-	-	-
i	HV700 x0,2mm	HV700 x0,2mm	*
kg	~0,046	~0,046	~0,046

B31, B32, B33

* = weicher Stahl / soft steel

Separat bestellen / Order separately

VS1R/F41L30-51

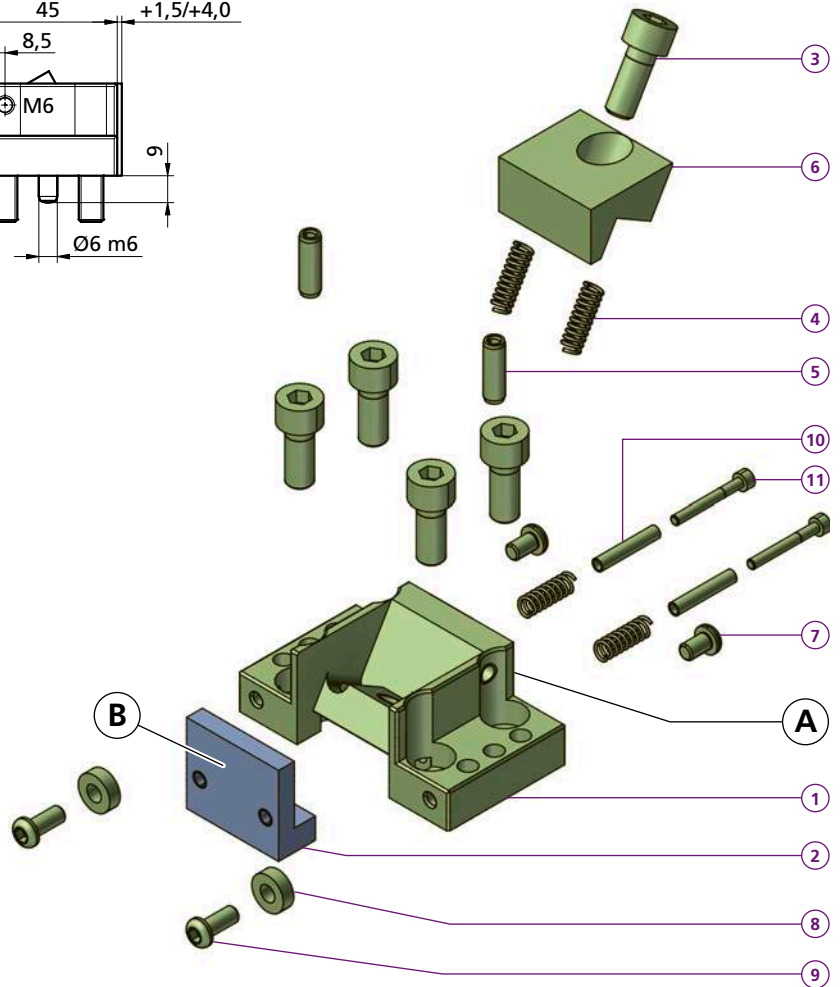
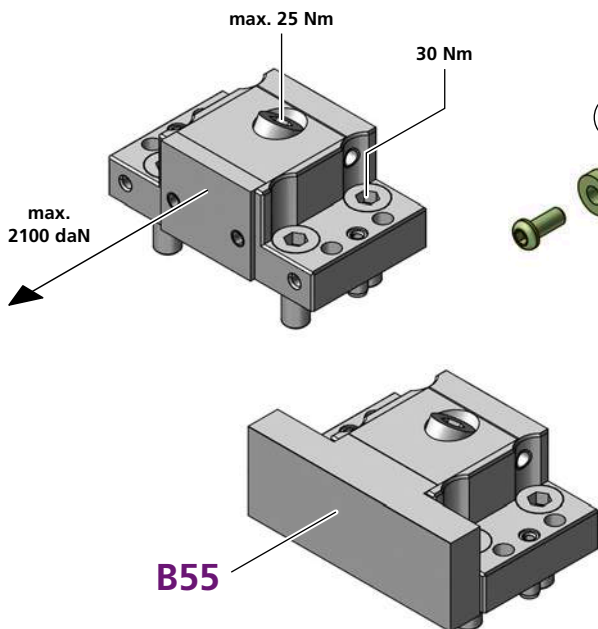
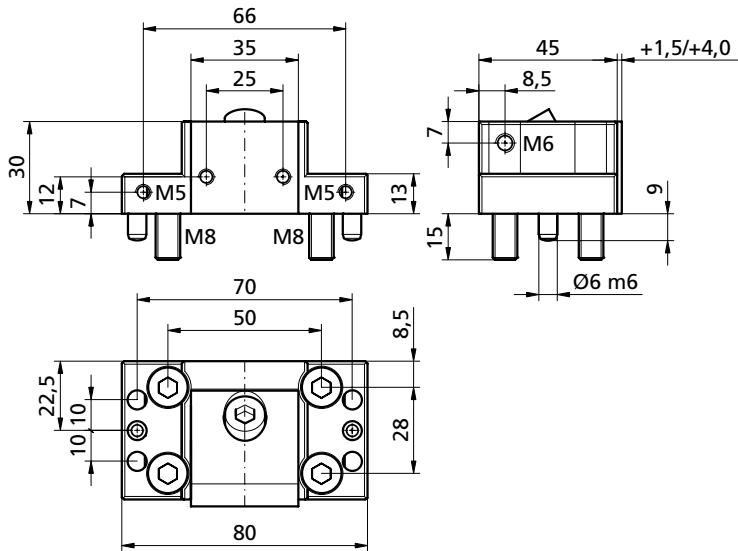

VS1F41L30-51	A
1x TF140727	
VS1R41L30-51	
1x TF140728	
1x	
5x M8X20ISO4762	
4x FED0618	
2x CCBO0802	
1x B78	
2x M5X8ISO7380	
2x CCD004	
2x M5X12ISO7380	
2x CCD422	
2x M3X25ISO4762	
kg ~0,545	

B Bestellbeispiel / Ordering example: 1x VS1R41L30-51 & 1x B52

	B51	B52	B53	B54	B55
C	35	35	35	35	80
H	30	30	30	35	30
L	6	6	10	10	11,5
D	-	-	-	-	-
e	-	-	-	-	-
i	HV700 x0,2mm	HV700 x0,2mm	*	*	*
kg	~0,06	~0,06	~0,06	~0,12	~0,27

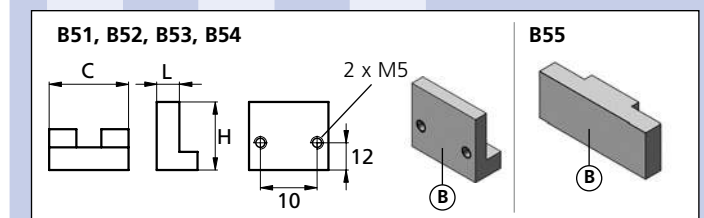

Separat bestellen / Order separately

Vorrichtungsbau-Modul für Linearbacken

Alle bestehenden Linearbacken passen auf dieses Modul
(**powerCLAMP** Seite **84 - 85**). In die Vorrichtungsplatte wird eine Tasche gefräst um das Modul zu positionieren. Gut geeignet sind die Anschlagbacken **MAND** und **MANF** um als Gegenbacke zu dienen.

Fixture clamp module for linear jaws

All of our standard linear jaws fit to this clamp module
(**powerCLAMP** Page **84 - 85**). All to do is milling a pocket to fit and positioning the clamp modules. To use the **MAND** and **MANF** as datum stop will make a perfect match. (Seite / Page **175 - 176**)

Fertigungsmasse für die Vorrichtungsplatte
Machining data for the fixture plate

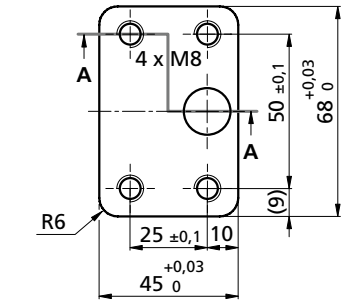

Schnitt / Section A-A

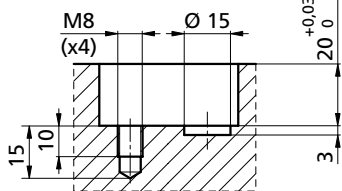

Das Fertigungsmass gilt auch für das Anschlagmodul.
The production dimension is also valid for the end module. (VA168-20PRG)

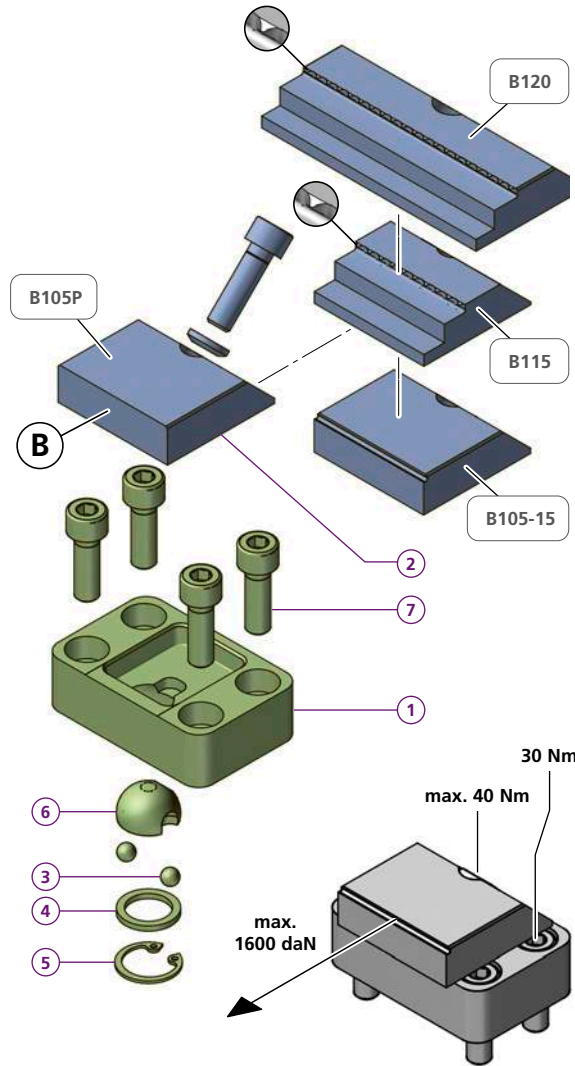
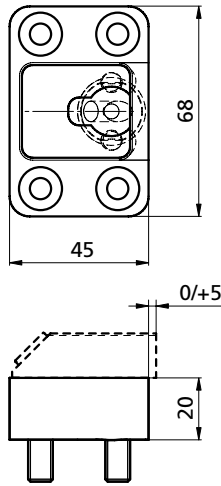

VS1X68L20-105	
1	1x TB150170
2	1x powerCLAMP p 84 - 85
3	1x BN869d=6
4	1x TN100747
5	1x TN100779
6	1x PCKMR45M8
7	4x M8X20ISO4762
kg	~0,42

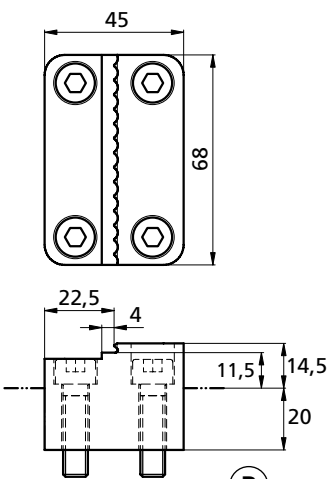

VA168-20PRG	
8	1x TH160280
9	4x M8X30ISO4762
kg	~0,75

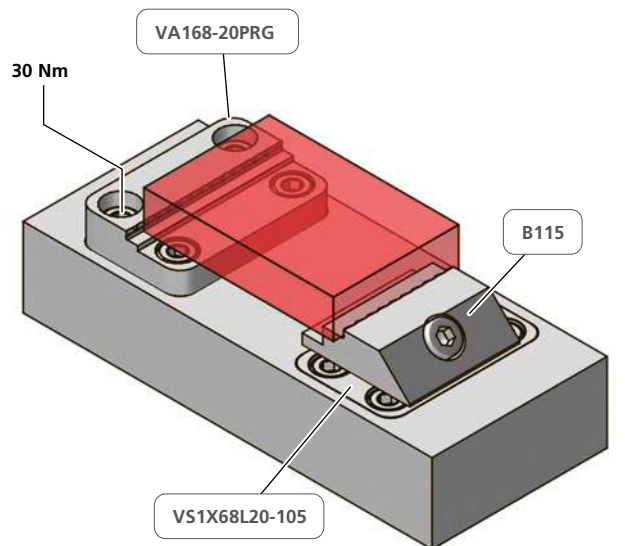
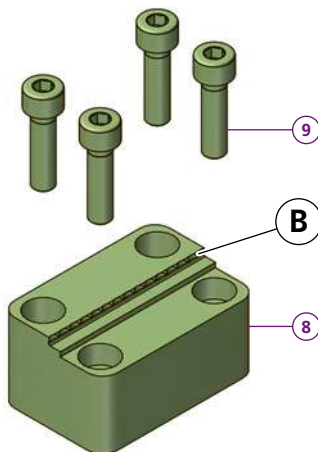

Bestellbeispiel / Ordering example: 1x VS1X68L20-105 & 1x B105P

Separat bestellen / Order separately

VS1F48L50-105
VS1P48L50-105

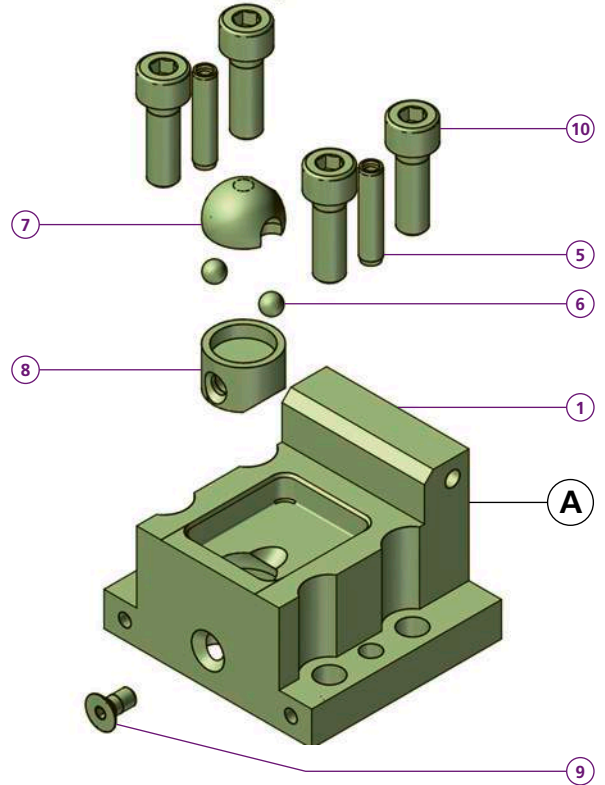
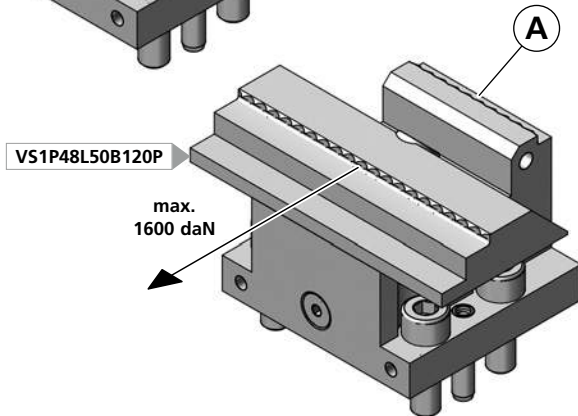
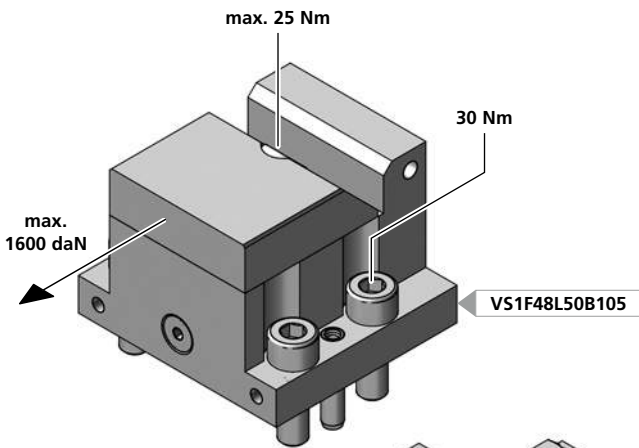
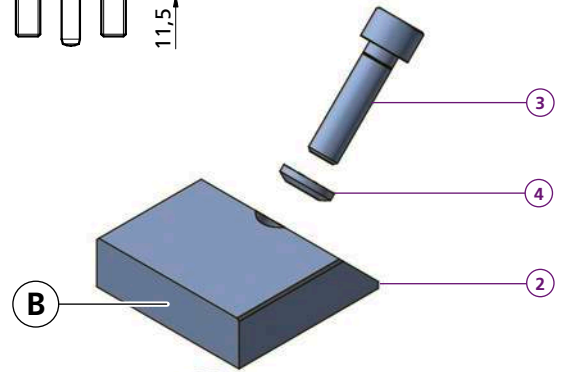
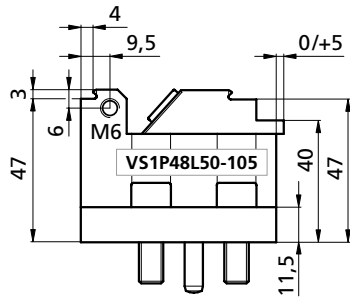
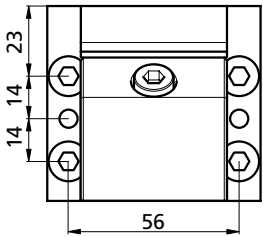
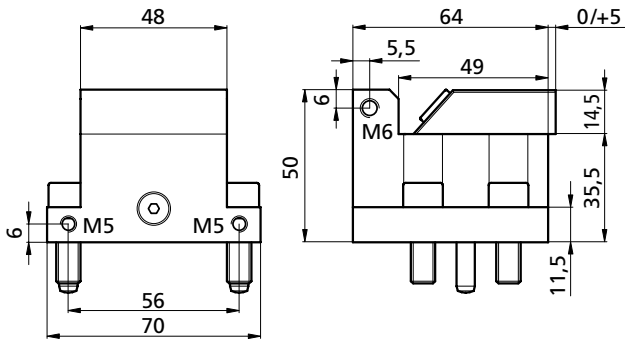

VS1F48L50-105	A
1x TK120807	
VS1P48L50-105	A
1x TK120761	
1x powerCLAMP	powerCLAMP p. 84 - 85
1x M8X30ISO4762	
1x PCUSR14	
1x 6-m6x26 DIN 79790	
2x BN869d=6	
1x PCKMR45M8	
2x TS120001-04	
1x M5X10DIN7991	
4x M8X25ISO4762	
kg ~1,21	

Bestellbeispiel / Ordering example: 1x VS1F48L50-105 & 1x B105

Separat bestellen / Order separately

VS1R/F80L30-51

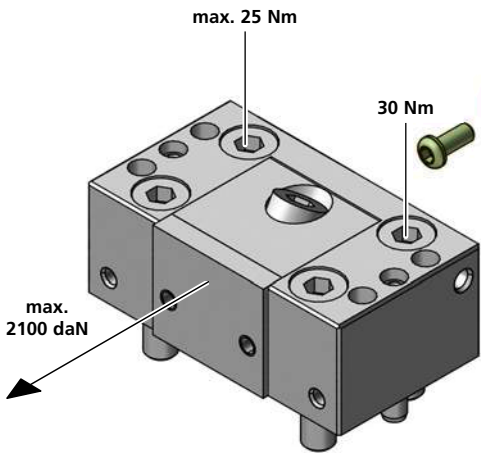
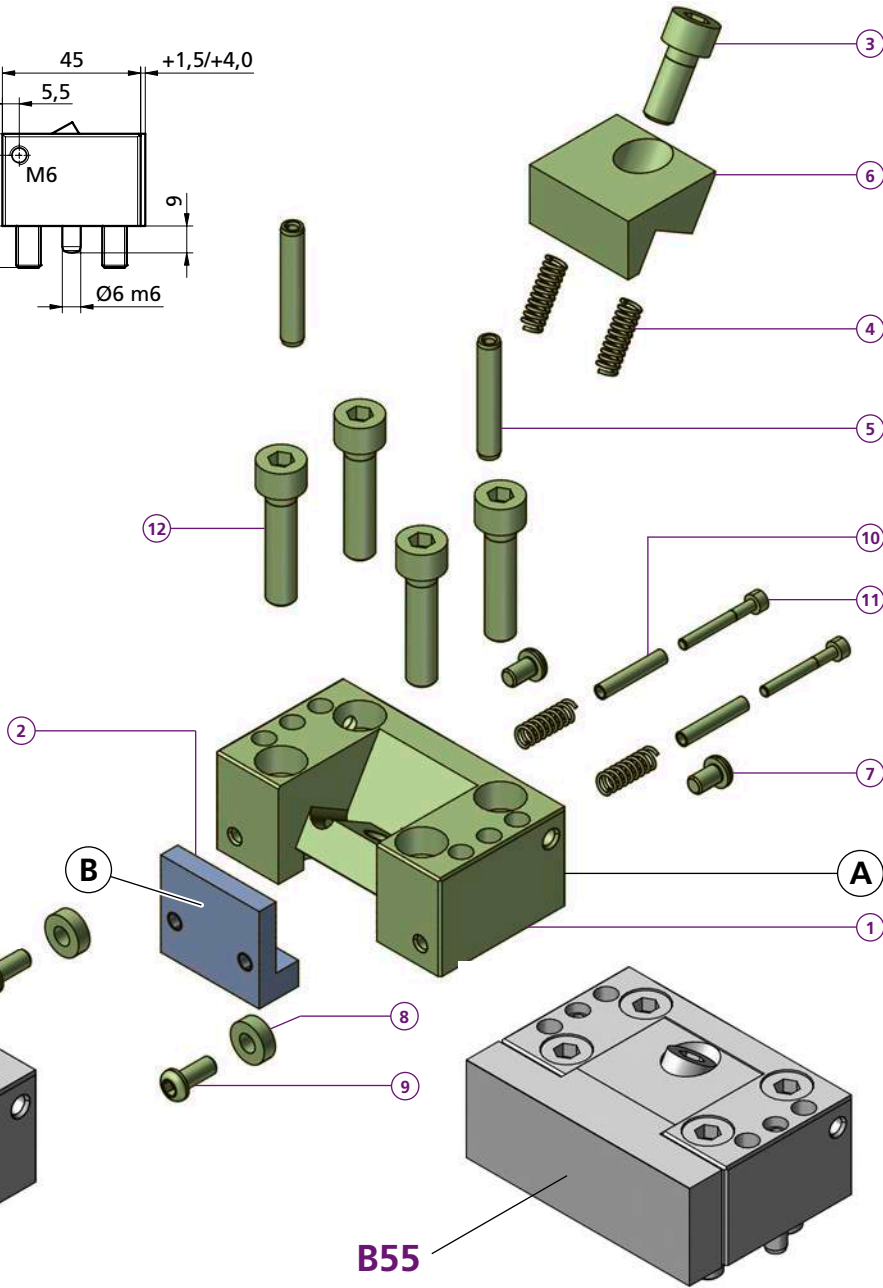
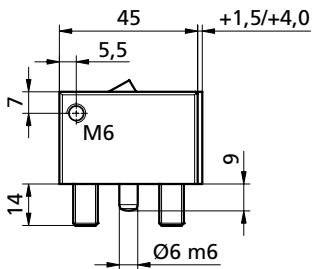
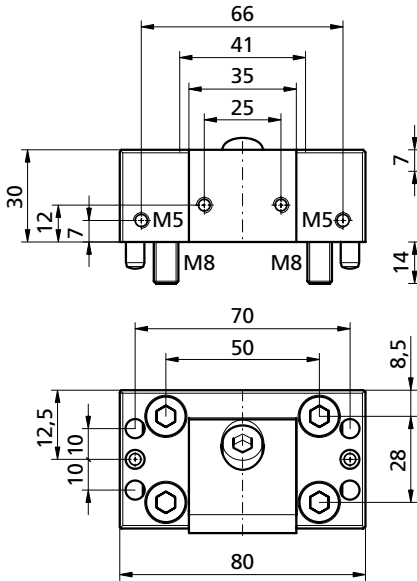

B55

VS1F80L30-51	
1	1x TF140731
VS1R80L30-51	
1	1x TF140732
2	1x
3	1x M8X20ISO4762
4	4x FED0618
5	2x CCBO0801
6	1x B78
7	2x M5X8ISO7380
8	2x CCD004
9	2x M5X12ISO7380
10	2x CCD422
11	2x M3X25ISO4762
12	4x M8X35ISO4762
kg	~0,74

B Bestellbeispiel / Ordering example: 1x VS1R80L30-51 & 1x B52

	B51	B52	B53	B54	B55
C	35	35	35	35	80
H	30	30	30	35	30
L	6	6	10	10	11,5
D	-	-	-	-	-
e	-	-	-	-	-
i	HV700 x0,2mm	HV700 x0,2mm	*	*	*
kg	~0,06	~0,06	~0,06	~0,12	~0,27

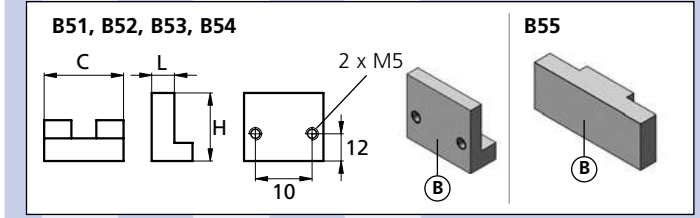

* = weicher Stahl / soft steel

Separat bestellen / Order separately

VS1X59L60K

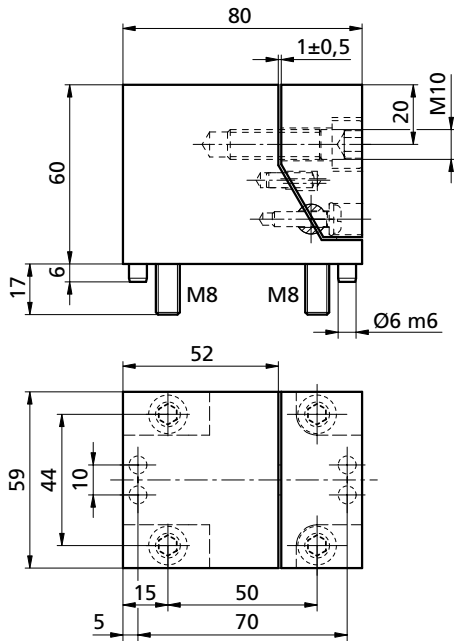

Empfohlener Sechskantschlüssel
Recommended hexagon wrench
PB2212L/6

100°

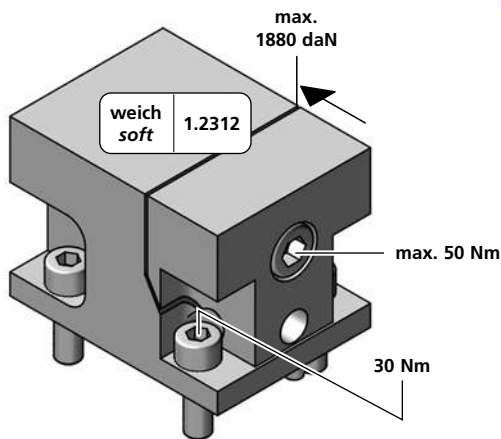
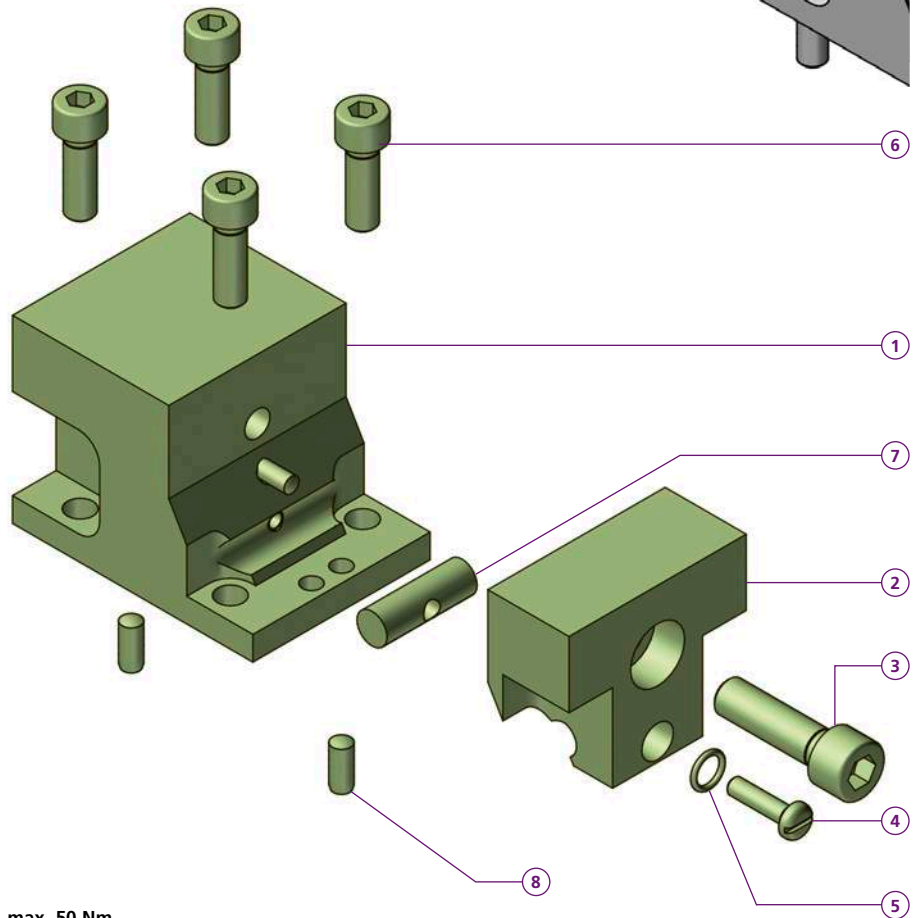

Spannstelle an Werkstück
angepasst und nitriert.
Clamping face machined to
the shape of the workpiece
and nitrided.

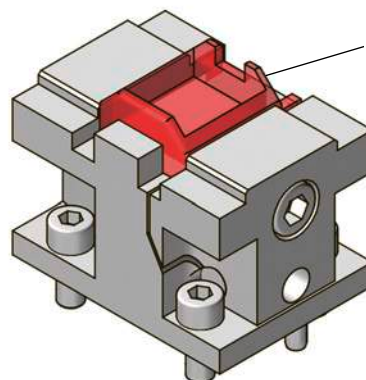

*VS1X59L60K

- ① 1x VS1X59L60H5KA
 - ② 1x VS1X59L60H5KS
 - ③ 1x M10X35ISO4762
 - ④ 1x M5X20DIN85A
 - ⑤ 1x ORØ8x1,5
 - ⑥ 4x **M8X25ISO4762**
 - ⑦ 1x VS1X59L60H5KG
 - ⑧ 2x 6m6x14 DIN 6325
- kg ~1,89

VS1X59L60H5

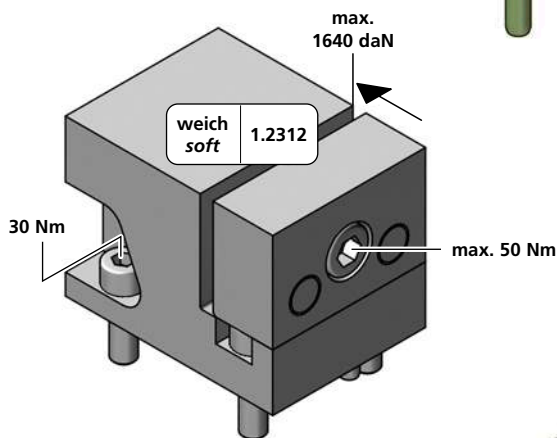
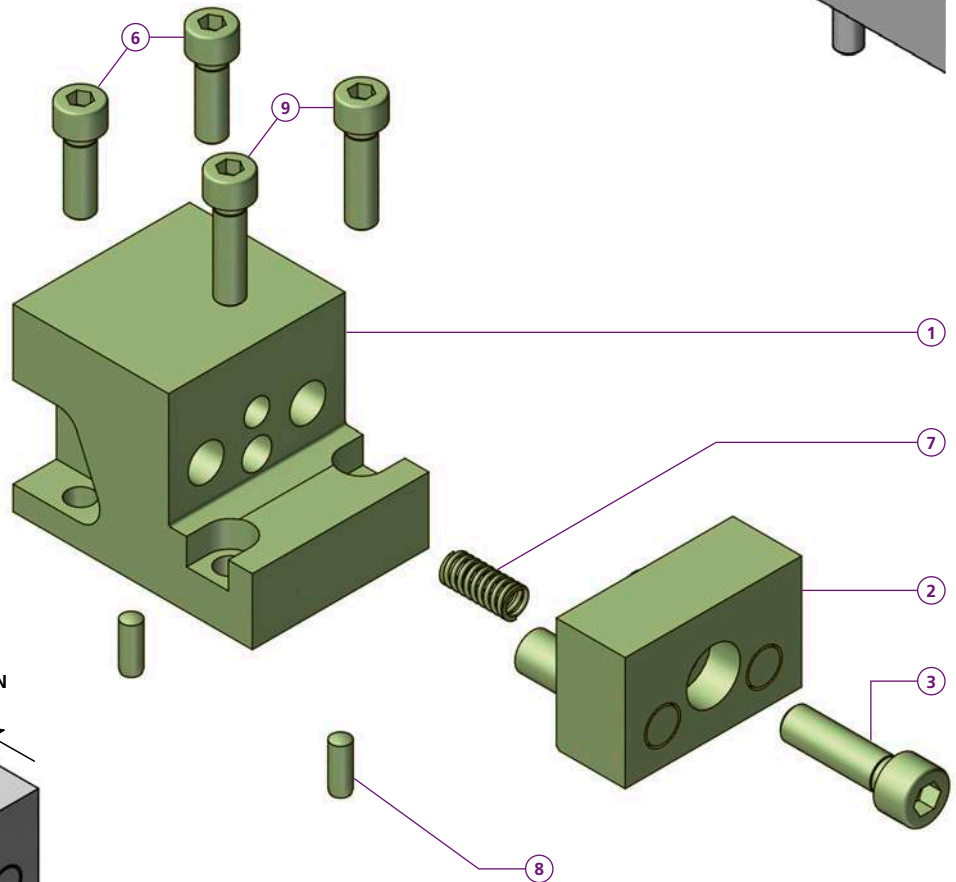
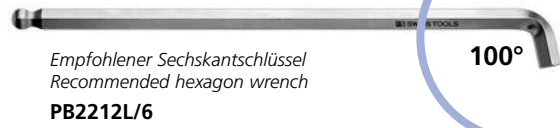
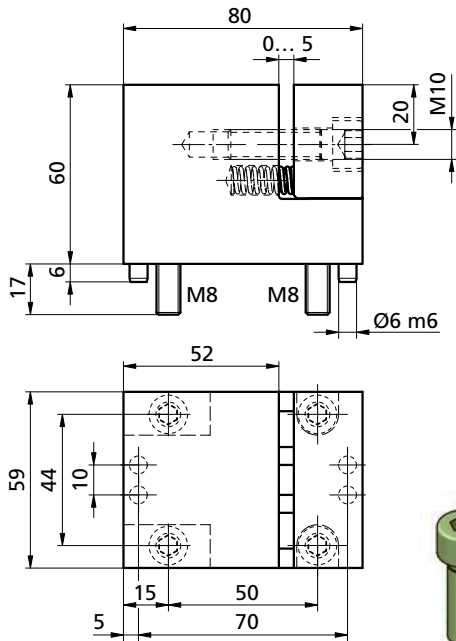

Anwendungsbeispiele
Sample applications

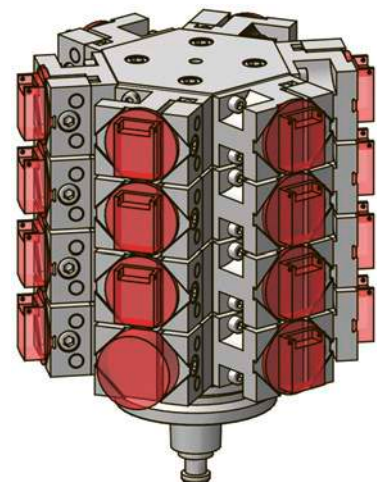
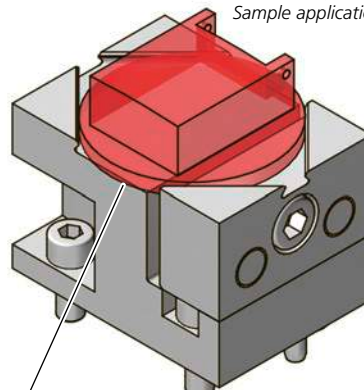

Spannstelle an Werkstück angepasst und nitriert.
Clamping face machined to the shape of the workpiece and nitrided.

*VS1X59L60H5	
1	1x VS1X59L60H5A
2	1x VS1X59L60H5S
3	1x M10X35ISO4762
6	2x M8X25ISO4762
7	1x FED0833
8	2x 6m6x14 DIN 6325
9	2x M8X30ISO4762
kg	~1,94

* = Stahl / steel 1.2312

Bestellbeispiel / Ordering example : **VS1X59L60H5**

Separat bestellen / Order separately

durchgehärtet / through hardened										nitriert / nitrated									
26mm	B	H	N	kg	41mm	B	H	N	kg	23mm	B	H	N	kg	41mm	B	H	N	kg
CCU15026	26	15	2,2	~0,017	CCU15081	41	15	2,2	~0,018	MCU11037	23	11	2	~0,004	CCU15083	41	15	3	~0,025
CCU20026	26	20	2,2	~0,02	CCU20081	41	20	2,2	~0,022	MCU15037	23	15	2	~0,006	CCU20083	41	20	3	~0,029
CCU25026	26	25	2,2	~0,022	CCU25081	41	25	2,2	~0,025	MCU18037	23	18	2	~0,008	CCU25083	41	25	3	~0,034
CCU30026	26	30	2,2	~0,025	CCU27581	41	27	2,2	~0,027	MCU20037	23	20	2	~0,008	CCU27583	41	27,5	3	~0,036
CCU32526	26	32,5	2,2	~0,026	CCU30081	41	30	2,2	~0,029	MCU22537	23	22,5	2	~0,008					
38mm	B	H	N	kg	80mm	B	H	N	kg	26mm	B	H	N	kg	80mm	B	H	N	kg
CCU30039	38	30	2,2	~0,028	CCU15080	79	15	2,2	~0,019	CCU15027	26	15	3	~0,024	CCU15082	79	15	3	~0,026
CCU35039	38	35	2,2	~0,031	CCU20080	79	20	2,2	~0,027	CCU20027	26	20	3	~0,027	CCU20082	79	20	3	~0,036
CCU40039	38	40	2,2	~0,035	CCU25080	79	25	2,2	~0,035	CCU25027	26	25	3	~0,03	CCU25082	79	25	3	~0,045
CCU45039	38	45	2,2	~0,039	CCU27580	79	27,5	2,2	~0,039	CCU30027	26	30	3	~0,033	CCU27582	79	27,5	3	~0,049
					CCU30080	79	30	2,2	~0,043	CCU32527	26	32,5	3	~0,034					
					CCU35080	79	35	2,2	~0,05										
					CCU40080	79	40	2,2	~0,057										
					CCU45080	79	45	2,2	~0,063										

03.01.2023

Schraubenzieher mit Konterung für
Screwdriver with holding sleeve for

CCBXSK

Positionsbolzen
Position pin

	L	kg
CCBO0801	36	~0,006
CCBO0802	20	~0,002
CCBO0803	50	~0,01

Bolzen-Auszieher
Pin puller

CCAZ1050

Positionierstift (spreizbar)
Locating pin (expandable)

CCBXM4
Ø 6x20

CCBX0802

MCZ40L30PRG13

Mehr Informationen siehe Zentrischspanner
For more information check the self centring vise

p. 116

MCZ100L50

Mehr Informationen siehe Zentrischspanner
For more information check the self centring vise

p. 127

Universalbacke / Universal jaw

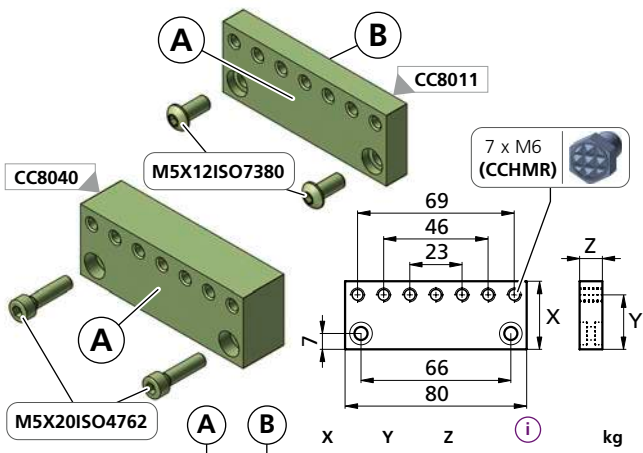

Part No.	A	B	X	Y	Z	Material	Weight (kg)
CC8011			30	24	10	56 HRC	~ 0,15
CC8025			50	44	10	56 HRC	~ 0,28
CC8040			30	24	20	*	~ 0,33

Weiche Backe / Soft jaw

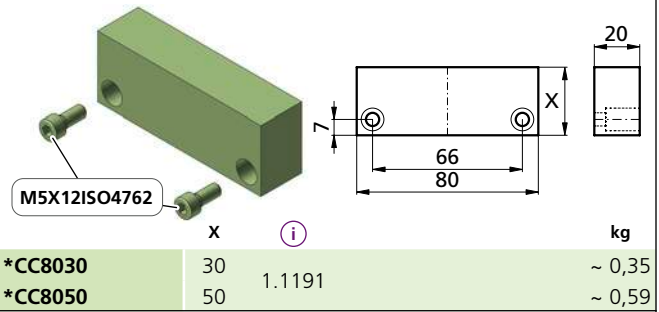

Part No.	X	Weight (kg)
*CC8030	30	~ 0,35
*CC8050	50	~ 0,59

Backe mit 2 Pendeldruckstücken / Jaw with 2 swivelling balls

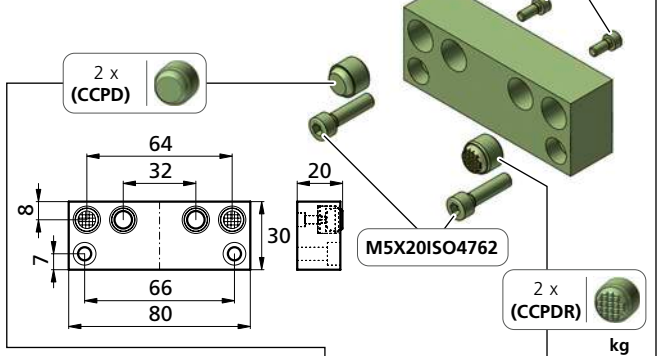

Part No.	Weight (kg)
CC8060	~0,30
CC8060R	~0,30

Backe für Druckstift / Jaw for pressure pin

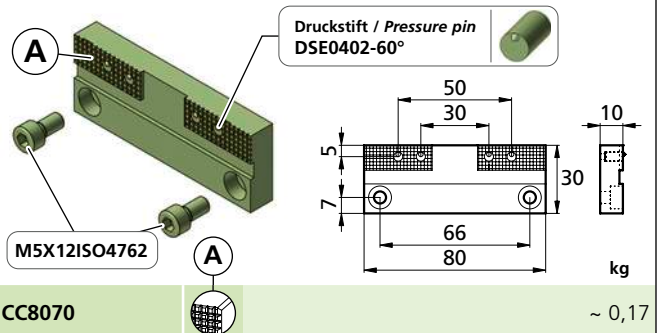

Part No.	Weight (kg)
CC8070	~ 0,17

Prismabacke / Prismatic jaw

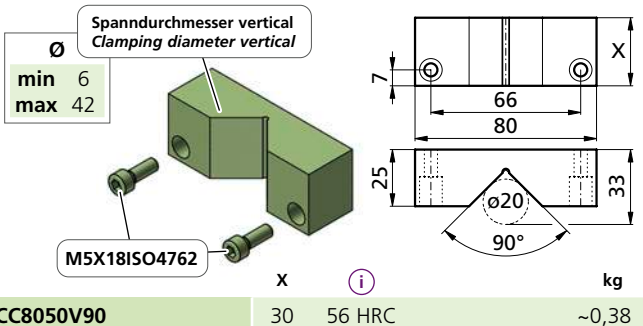

Part No.	X	Material	Weight (kg)
CC8050V90	30	56 HRC	~0,38

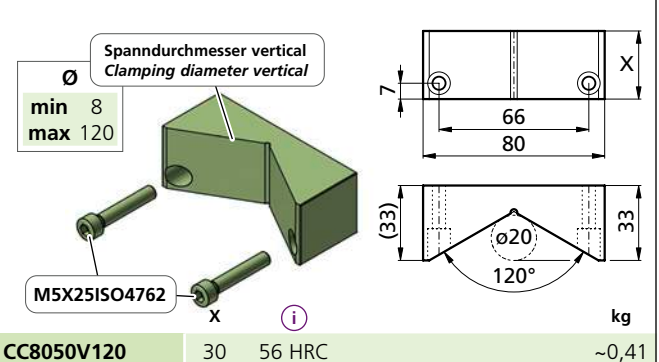

Part No.	X	Material	Weight (kg)
CC8050V120	30	56 HRC	~0,41

Backe / Jaw

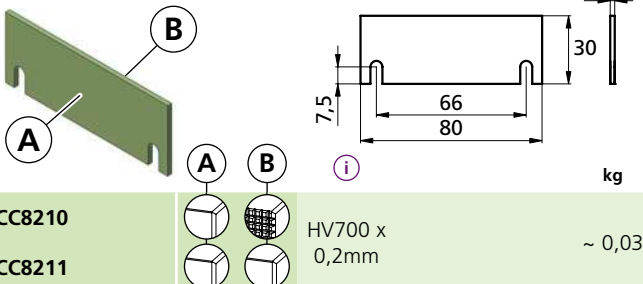

Part No.	Material	Weight (kg)
CC8210	HV700 x 0,2mm	~ 0,03
CC8211	HV700 x 0,2mm	~ 0,03

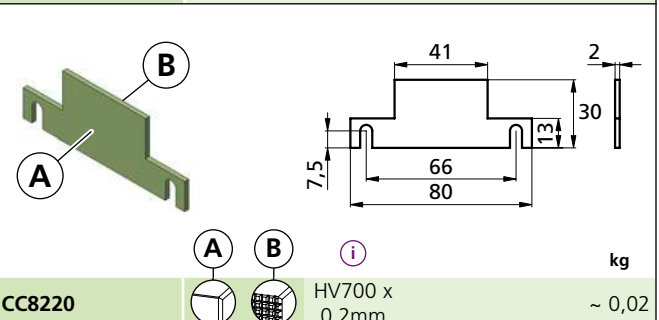

Part No.	Material	Weight (kg)
CC8220	HV700 x 0,2mm	~ 0,02

* = weicher Stahl / soft steel

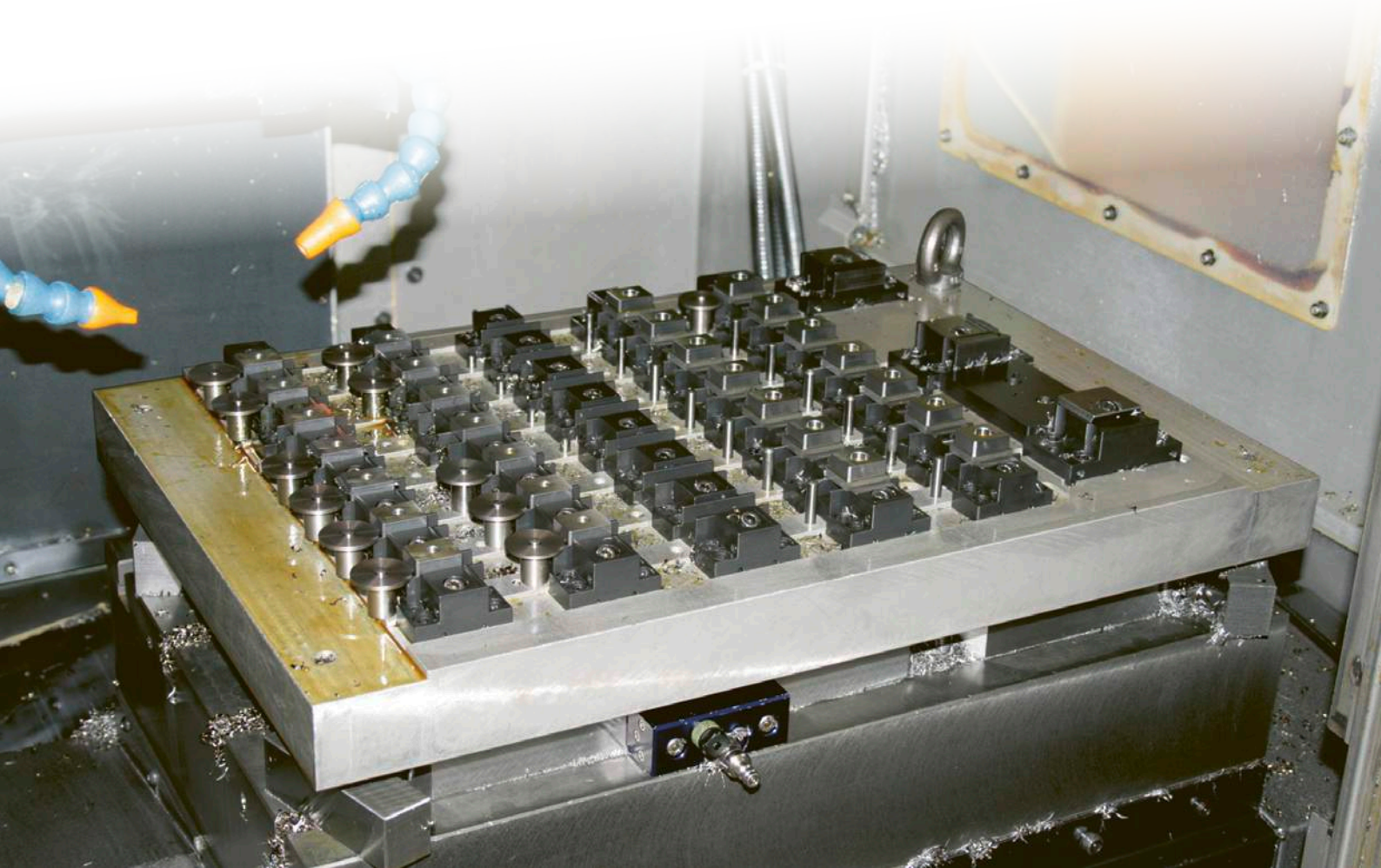
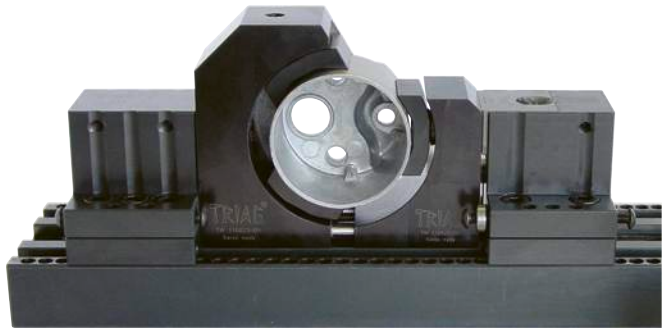
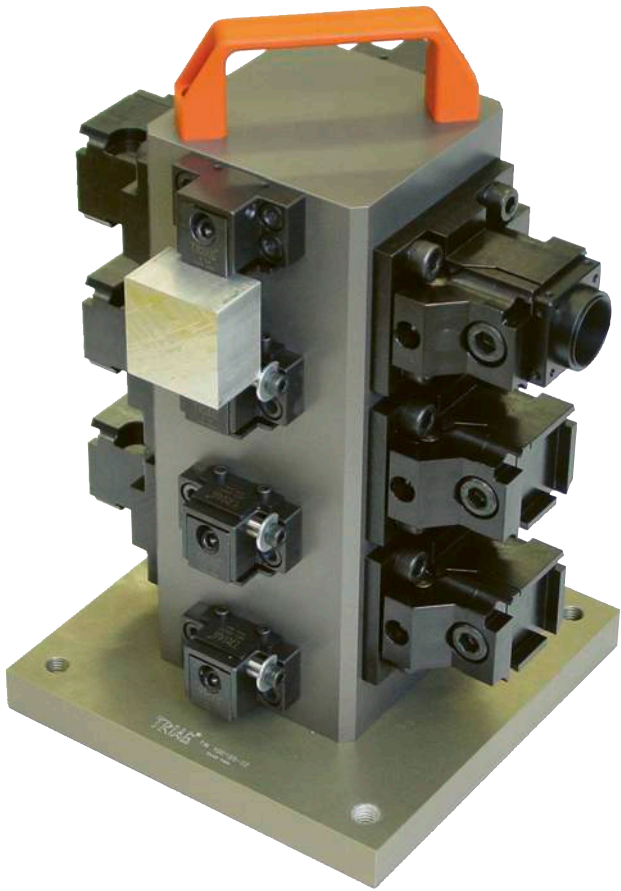

Bestellbeispiel / Ordering example: CC8011



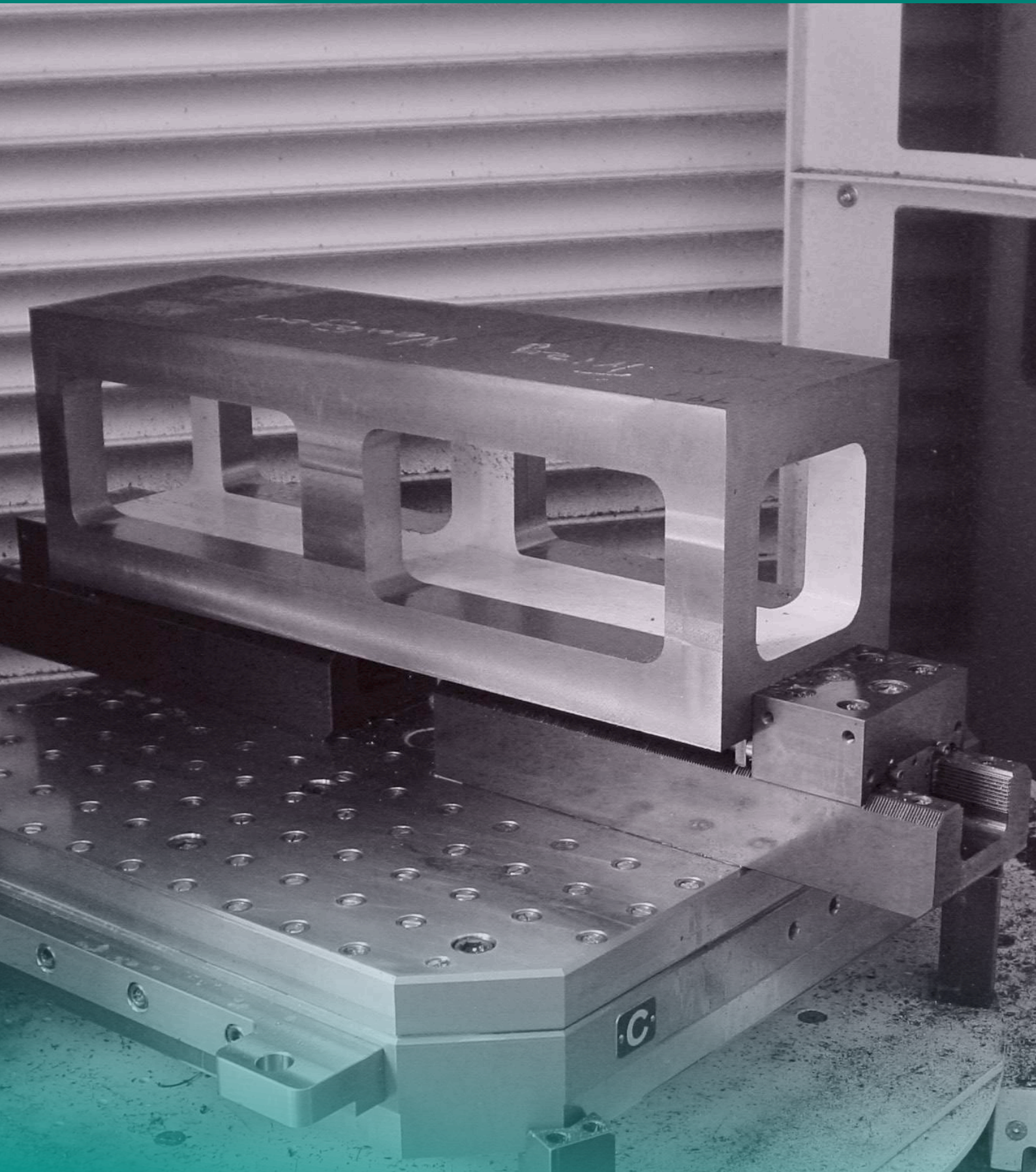

*apto*CLAMP & *5axes*

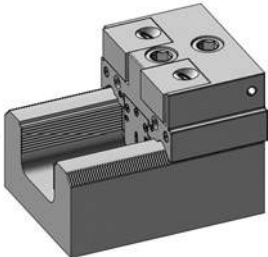
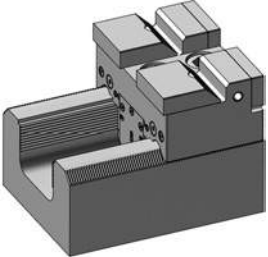
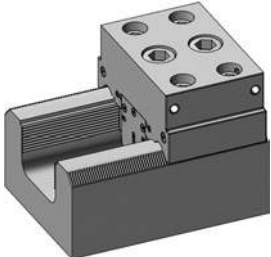
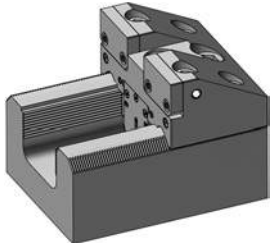
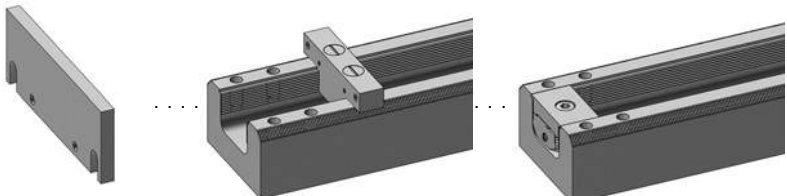

	Einleitung <i>Introduction</i>	209 - 212
	Bedienungsanleitung <i>Operating manual</i>	213 - 214
	Anwendungsbeispiele <i>Examples of application</i>	215 - 220
	Basisschiene <i>Base-rail</i>	222
		
	Niederzugspannmodule <i>Pull down clamp modules</i>	223 - 226
		
	Linearspannmodule mit Präge- und Linearbacken <i>Linear clamping modules with stamping and linear jaws</i>	227
		
	Anschlagmodule <i>End module</i>	228 - 230
		
	5-Achs Linearanschlagmodule mit Präge- und Linearbacken <i>5-axis linear clamping modules with stamping and linear jaws</i>	231
		
	Zubehör <i>Accessories</i>	232 - 233
		

Die Idee des Mehrfachspannens The idea of multiple workholding

Schwerstzerspannung / Heavy duty machining

aptoCLAMP

Die hohe Spannkraft dieses Systems ermöglicht den Einsatz für schwere Zerspanung.

Mit stabilen Kraftspannern können auf den Basisschienen auch grosse, bis zu mehrere tausend Kilogramm schwere Platten und Blöcke gespannt werden.

The high clamping force of the Apto Clamp enables heavy cuts. You achieve maximum rigidity with our Apto Clamp modular system! Even if your workpiece is thousands of kilograms you don't have to worry to clamp big parts and big plates.

Elefantenstark und anwenderfreundlich Powerful and user-friendly



Zur Positionierung der Spannmodule hat das Apto Clamp neben einer Querverzahnung zusätzlich ein Ankersystem zur Arretierung an einer Längsverzahnung in der Basischiene. Durch die rechtwinklige Verkeilung wird eine von Mitbewerbern unerreichte Stabilität gewährleistet. Die Spannmodule liegen auf der genau geschliffenen Auflagefläche der Basis auf. Durch das Ankersystem und die geschliffene Auflagefläche wird das Spannmodul an der Basischiene extrem kraftschlüssig und präzise fixiert. Trotzdem können die Spannmodule völlig ungehindert entlang der Basis verstellt (verschoben) werden. Auch das Auswechseln der Module ist einfach, müssen doch diese nicht aus der Schiene ausgefahren, sondern können abgehoben werden.

For positioning the clamp modules on the base rails, has the Apto Clamp system next to a positioning serration a horizontal anchor system for locking with enormous force produced by two M16 screws. The end modules have additionally 4 M12 screws to give extra rigidity.



The end modules have additionally 4 M12 screws to give extra rigidity.

Schnelligkeit / Quickness



Zwei Schraube lösen
Loosen two screws



Abheben und neu platzieren
Lift and change position



Zwei Schrauben anziehen
Fasten two screws

Vorteile auf einen Blick / Benefits at a glance:

- ➔ Sehr stabil, robuste Bauweise, dadurch hohe Präzision
Very stable, robust design allows high precision and heavy machining
- ➔ Module nach oben abhebbar, kein Ausfahren nötig
Modules can be lifted up, no extension needed
- ➔ Keine verschmutzbaren T-Nuten: Formschlüssig positioniert
No chip loading T-slots grooves: Positively positioned
- ➔ Verzahnung nicht dem Werkstück ausgesetzt
The teeth are not exposed to the workpiece
- ➔ Niederzug- und Linearspannung möglich
Pull-down and linear clamping possible
- ➔ Spannkraft bis 7000 daN pro Modul
Clamping force up to 7000 daN per module

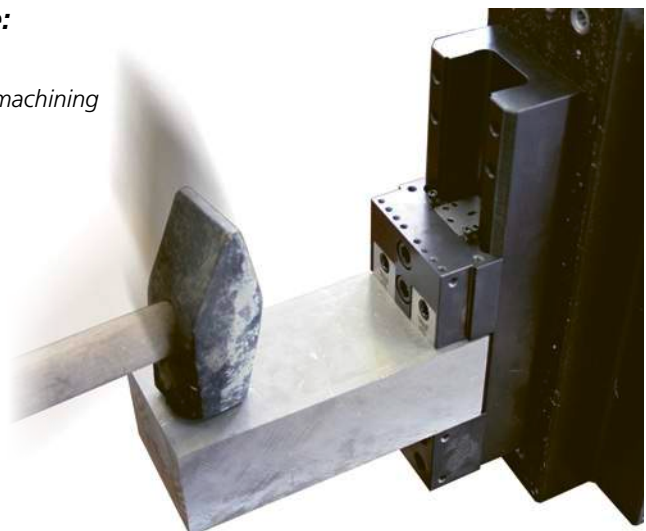

400 mm

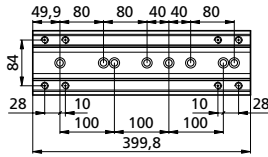

450 mm

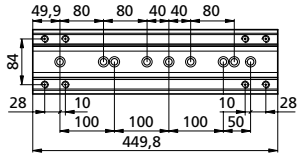

500 mm

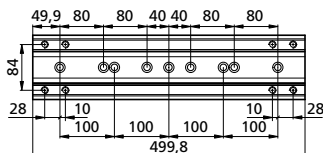

550 mm

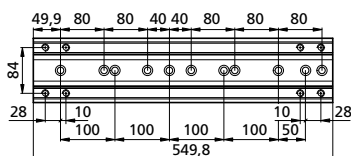

600 mm

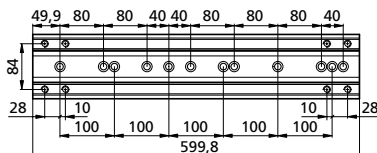

650 mm

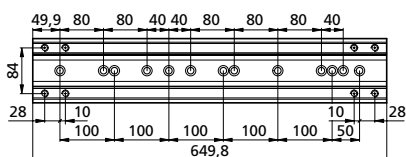

700 mm

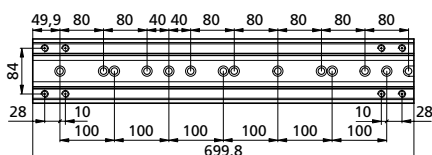

750 mm

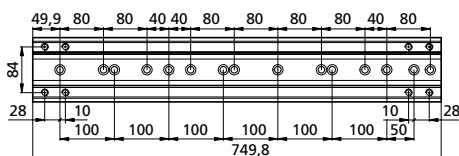

800 mm

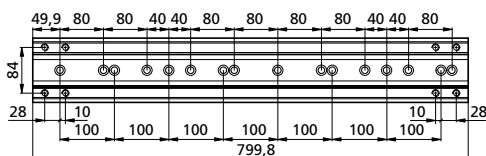

Basisschiene / Base rail

Beim Apto Clamp ermöglicht eine Verzahnung mit 2 mm-Teilung auf der Basisschiene ein schnelles und genaues Positionieren der Spann- und Anschlagmodule.

With the new Apto Clamp a serration of 2mm pitch on the base rail allows a rapid and accurate positioning of the modules.

Durch gezielte elastische Deformation einer Lippe erfolgt eine spielfreie Paarung. Spann- und Bearbeitungskräfte werden einerseits an der ebenen, robusten Oberseite der Basisschiene aufgenommen, während andererseits das Spannmodul durch einen spreizenden Keil mit robustem Rundgewindeprofil in der Schiene verankert wird.

The outstanding development is that through elastic deformation of a lip, the engagement between the modules and the base rail is without play. Clamping and machining forces are absorbed on the upper surface of the base rail whereas the vice module is fixed to the rail by an expandable anchor which engages the round serration inside the base rail.

Das Einfügen zusätzlicher Module zwischen bestehenden Spannstellen ist problemlos möglich. Apto Clamp ist die konsequente Weiterentwicklung von Power Clamp zur Bearbeitung noch grösserer Werkstücke.

The insertion of additional vice modules can be accomplished without problems. Apto Clamp is the logical development of Power Clamp to handle even larger work pieces.

Schnittzeichnung Sectional view of der Basisschiene the base rail

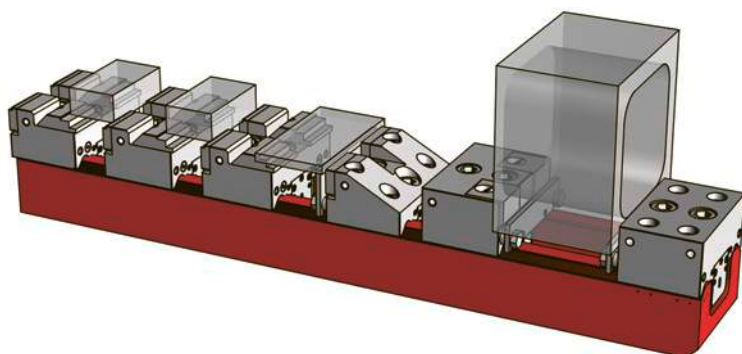
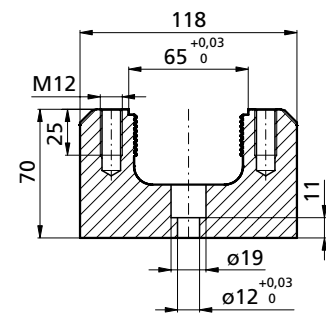

Das Anschlagmodul / End modules

In der Regel ist nur ein Anschlagmodul als „feste Backe“ erforderlich.

In general, only a stop module is required as a „fixed jaw.“

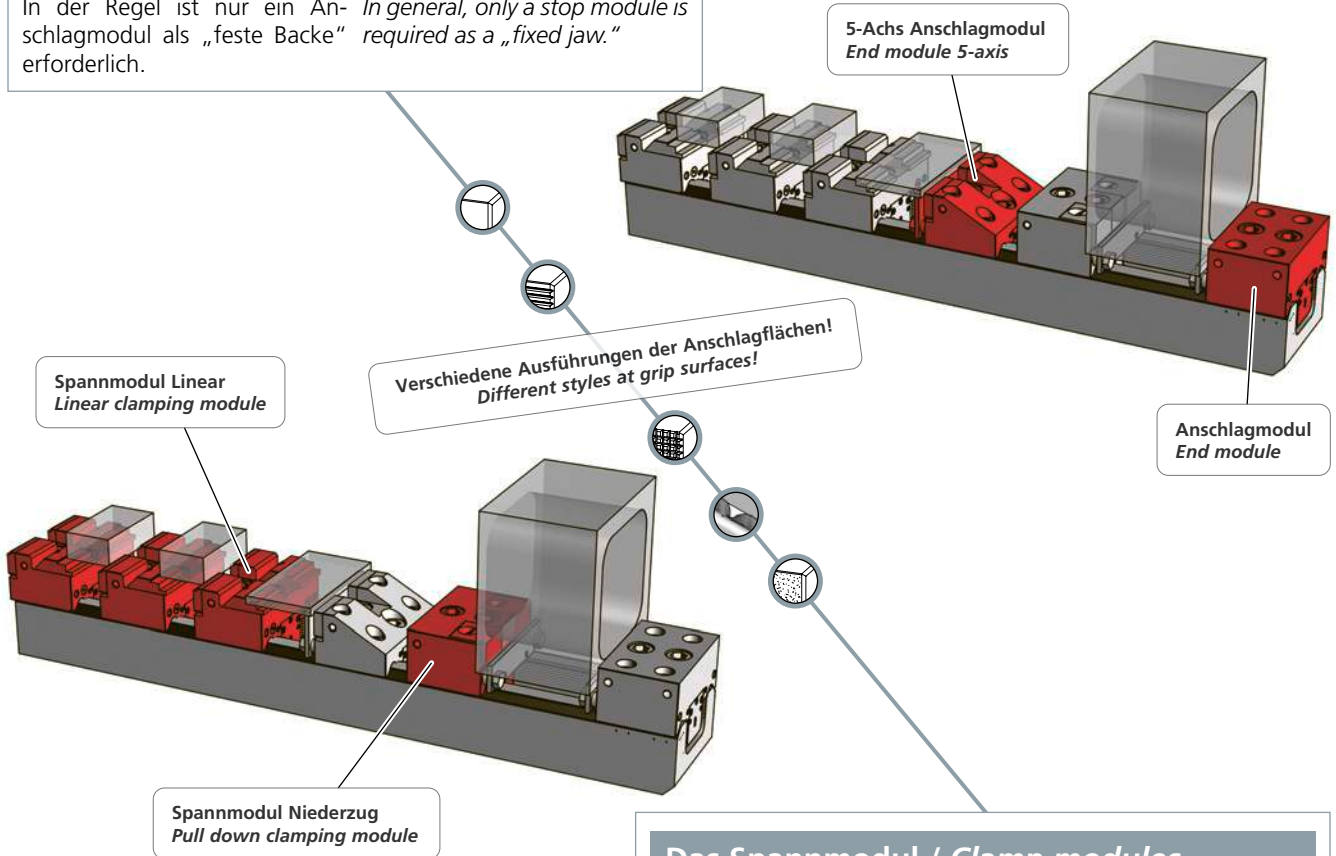

Das Spannmodul / Clamp modules

Die «beweglichen Backen» gibt es in zwei Ausführungen. Zum einen für das Niederzugspannsystem und zum anderen für das Linearspannsystem. Dabei dient das Spannmodul bei den Systemen wiederum als Anschlagmodul für die nächste Aufspannung.

Clampe modules have movable jaws (linear or pull down) in the front to clamp the part and on the back there is the datum face for the next work piece stop. Positioning step on the base rail is 2mm every.

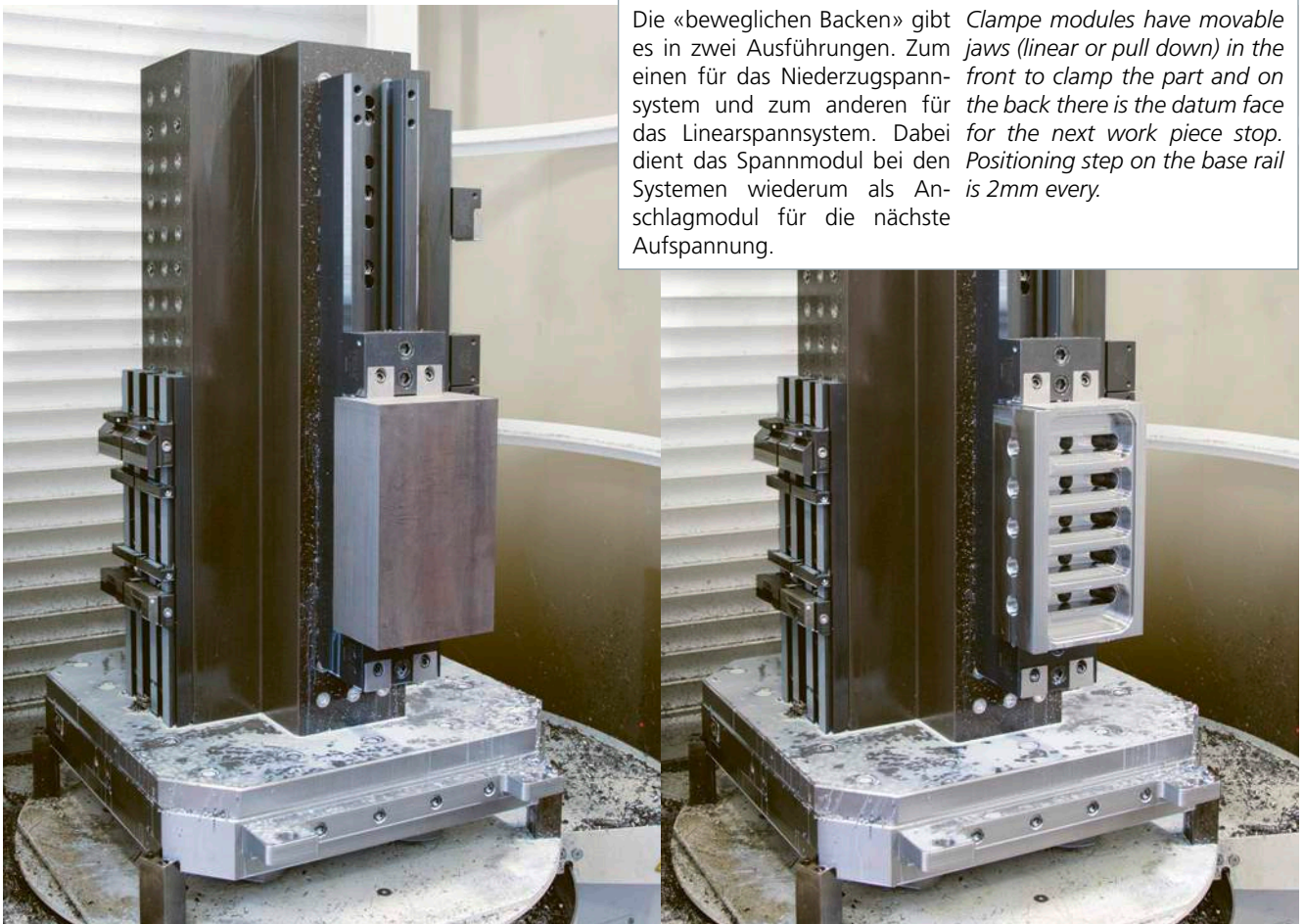

Niederzugspannmodule Pull down clamp modules

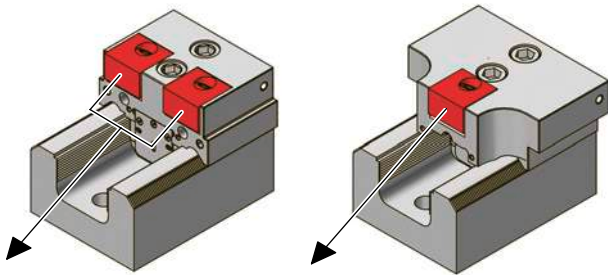

Die Fakten beim Niederzugspannsystem

Verstellbereich: 0- 3,8 mm
Spannkraft: Bis 7'000 daN

Vorteile beim Niederzugspannsystem:

- Höhere Haltekräfte
- Hohe Wiederholgenauigkeit
- Optimale Spannmethode für Kleinteile
- Mit Schnellwechselbacken
- Doppelspannsystem in einer Backe zum Spannen und Bearbeiten von zwei Kleinteilen

Facts for pull down clamp modules

Jaw range: 0- 3,8 mm
Clamping force: up to 7'000 daN

Advantages pull down jaws:

- Higher holding force
- With linear adaptable jaws
- Also with pull down jaws for the stop side available
- With adapter set can be changed to linear
- Also pull down jaws for datum face

Linearspannmodule Linear clamp modules

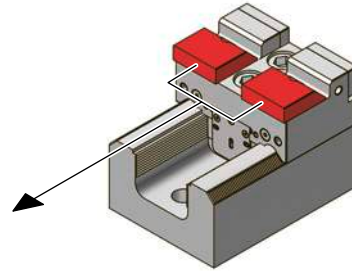

Die Fakten beim Linearspannsystem

Verstellbereich: 0- 5,0 mm
Spannkraft: Bis 3'200 daN

Vorteile beim Linearspannsystem:

- Spannstockähnliches Spannen
- Prozesssichere Positionierung der zweiten Aufspannung
- Gut geeignet für die Erstellung von individuellen Formbacken
- Sicherer Halt mit Prägetechnik

Facts for linear clamp modules

Jaw range: 0- 5,0 mm
Clamping force: up to 3'200 daN

Advantages linear jaws:

- Similar clamp as conventional vise
- Good for shaped jaws
- Secure clamped with direct stamping jaws
- Higher accuracy

Universalnutstein Universal nut

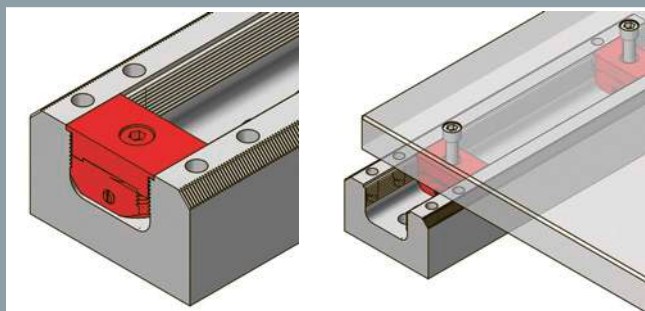

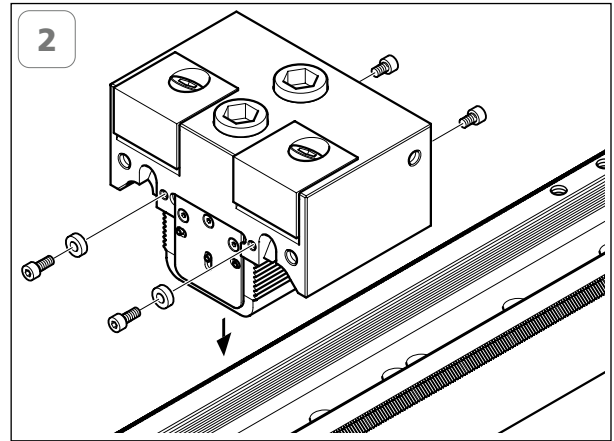
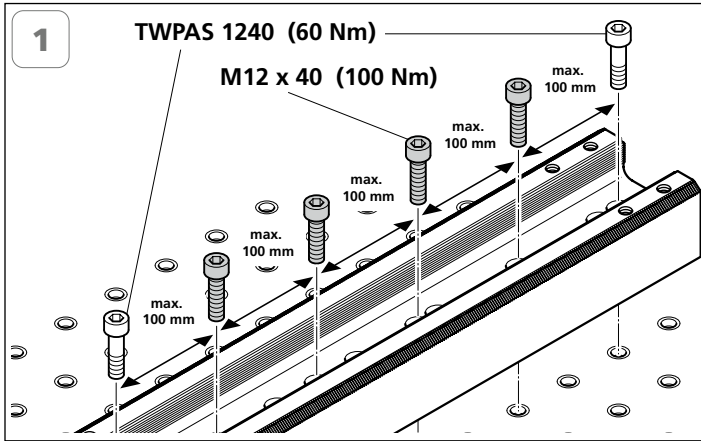

Ineinandergreifen der Verzahnung prüfen
Check matching of the teeth

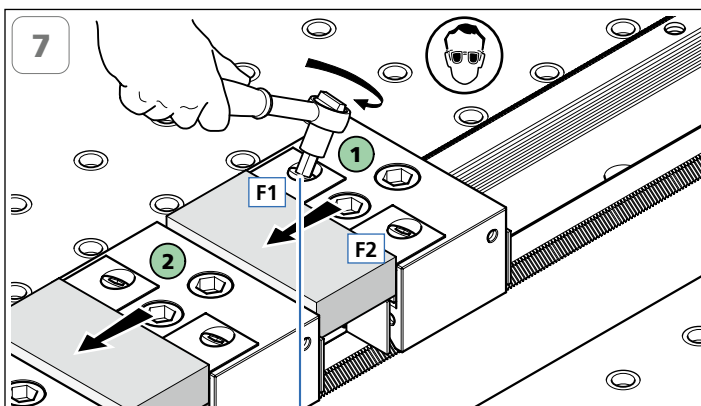
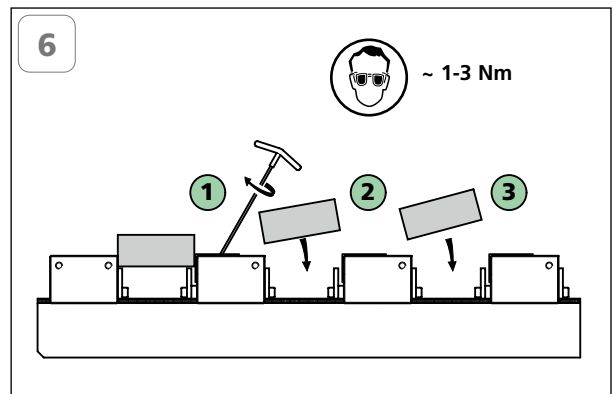
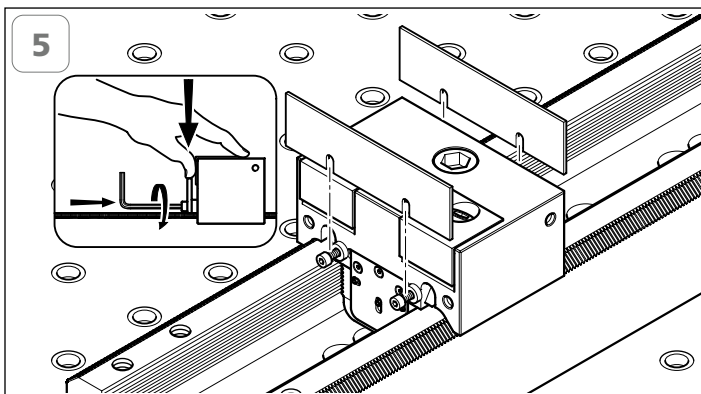
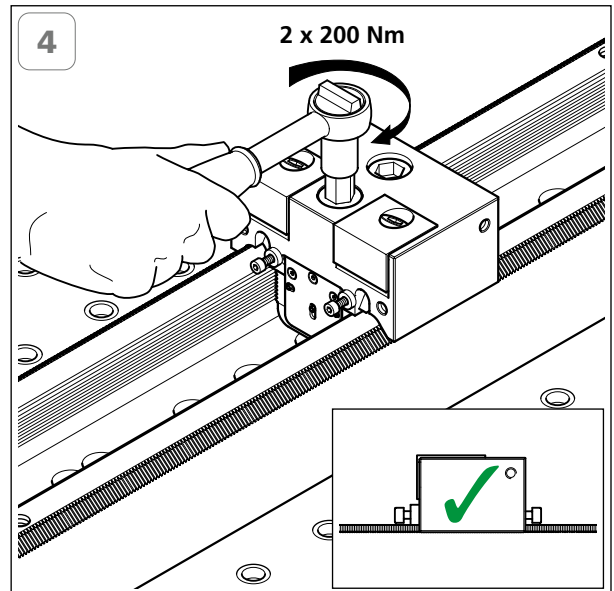
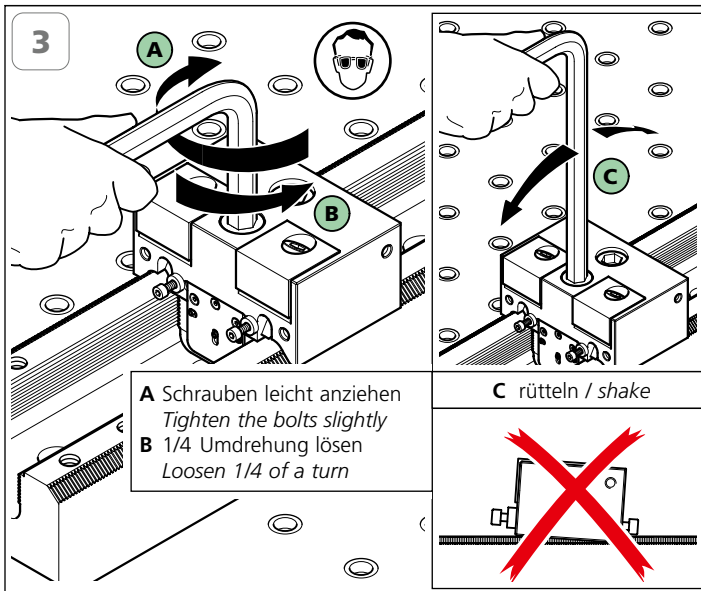

max. Drehmoment beachten
Observe max. torque

Schraube Screw	Drehmoment Torque		Spannkraft (F1 & F2) Workholding force (F1 & F2)		
	Nm	(lb-ft)	~daN	~(lb)	~t
M10	10	7,4	= 1200	2'650	1,2
	20	14,8	= 2700	5'950	2,7
	30	22,2	= 4100	9'040	4,1
	40	29,5	= 5600	12'350	5,6
	50	37,0	= 7000	15'430	7,0

max. Nm

ACHTUNG / CAUTION

WICHTIG: Die angegebenen Drehmomente sind die absoluten Maximalwerte. Über die Spannkräfte gibt die untenstehende Tabelle Auskunft.

IMPORTANT: The torque numbers specified represent the absolute maximum. The table at the bottom of this page provides further information on the workholding forces.

Schraube Screw	Drehmoment Torque		Spannkraft (F1 & F2) Workholding force (F1 & F2)		
	Nm	(lb-ft)	~daN	~(lb)	~t
M10	10	7,4	= 1200	2'650	1,2
	20	14,8	= 2700	5'950	2,7
	30	22,2	= 4100	9'040	4,1
	40	29,5	= 5600	12'350	5,6
	50	37,0	= 7000	15'430	7,0

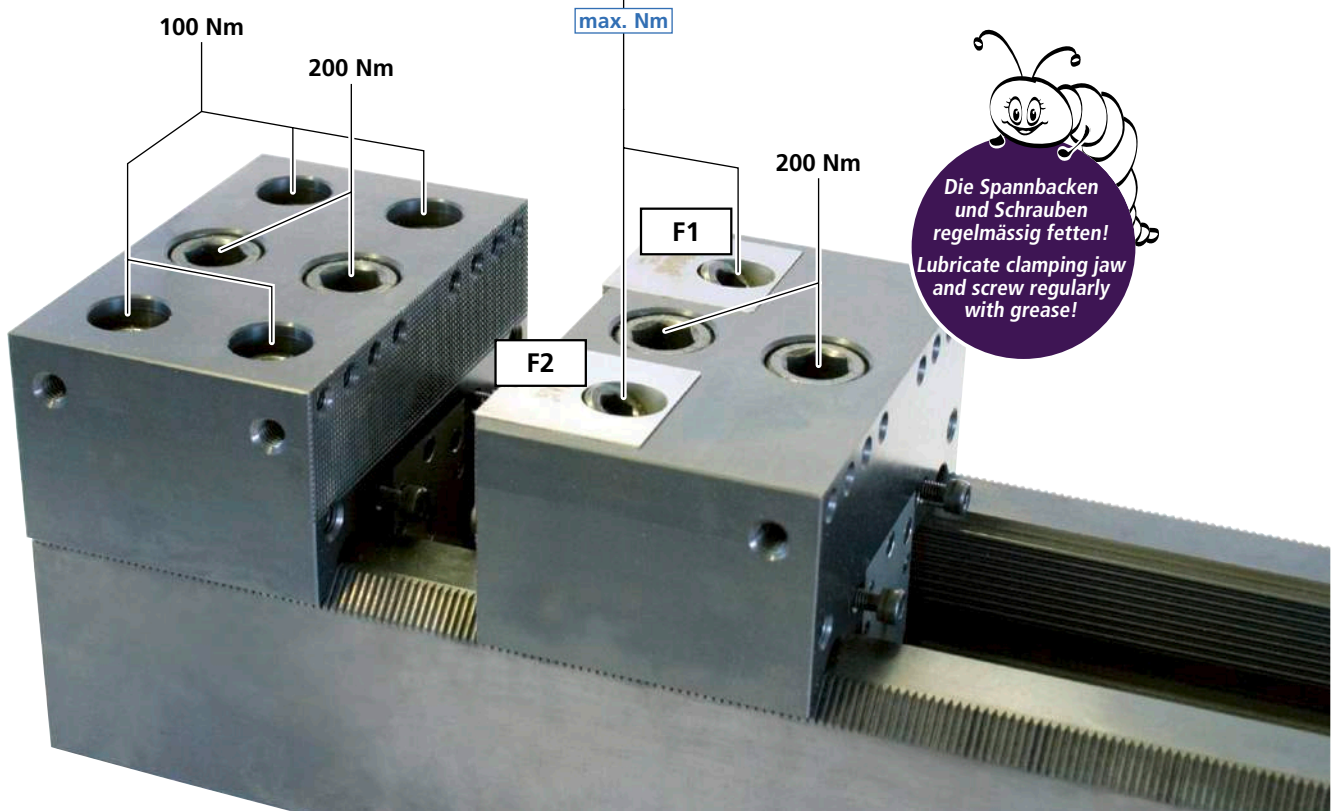

WICHTIG: Vor dem Positionieren der Spannmodule für ein neues Werkstück ist die Spannbacke ganz zurück zu stellen, dies gewährleistet eine sichere Spannung (siehe Bild A)!

IMPORTANT: Prior to setting up a new clamping module the clamping jaw of the vice module must be retracted all the way (see picture A)! This guaranties proper clamping of the new workpiece.

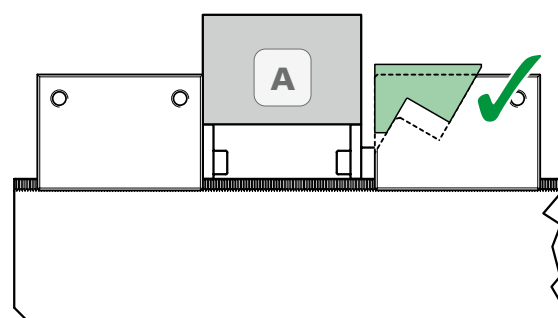
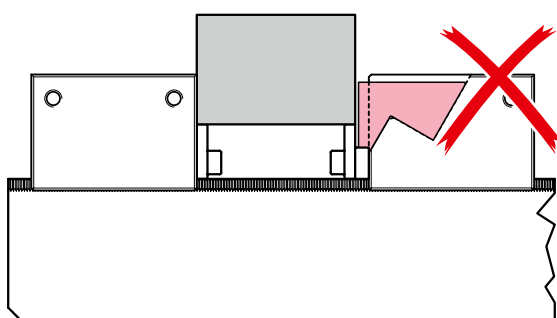

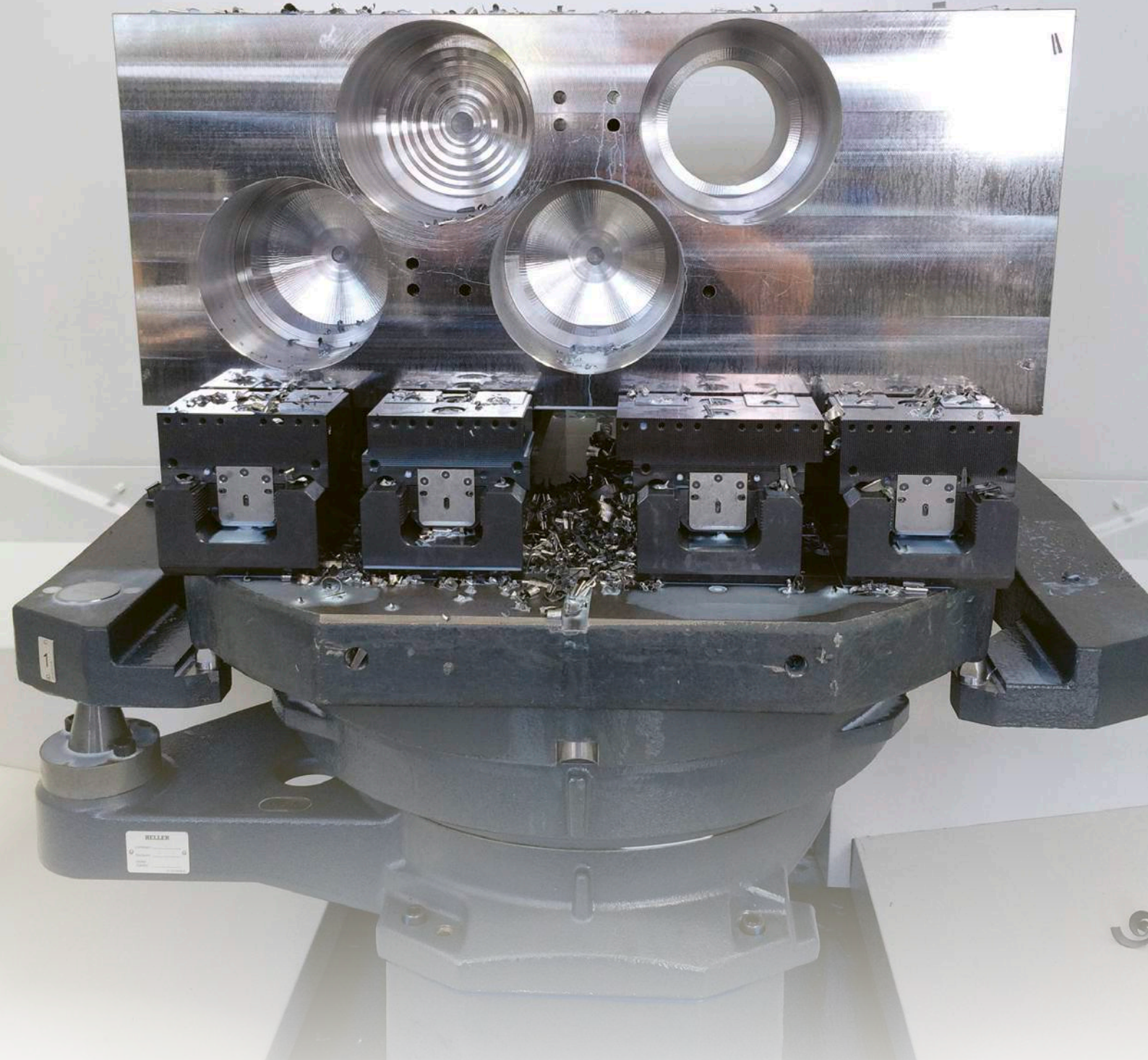

Material	42Cr Mo4
Bearbeitung mit Fräskopf	Ø 200
Machining with milling head	
Bohrer / Drills	Ø 124
Einspanntiefe / Clamping depth	24mm

Apto Clamp in der Schwerzerspannung auf Heller 5-Achsen-Maschine
Apto Clamp for heavy duty machining on a 5-axis machine

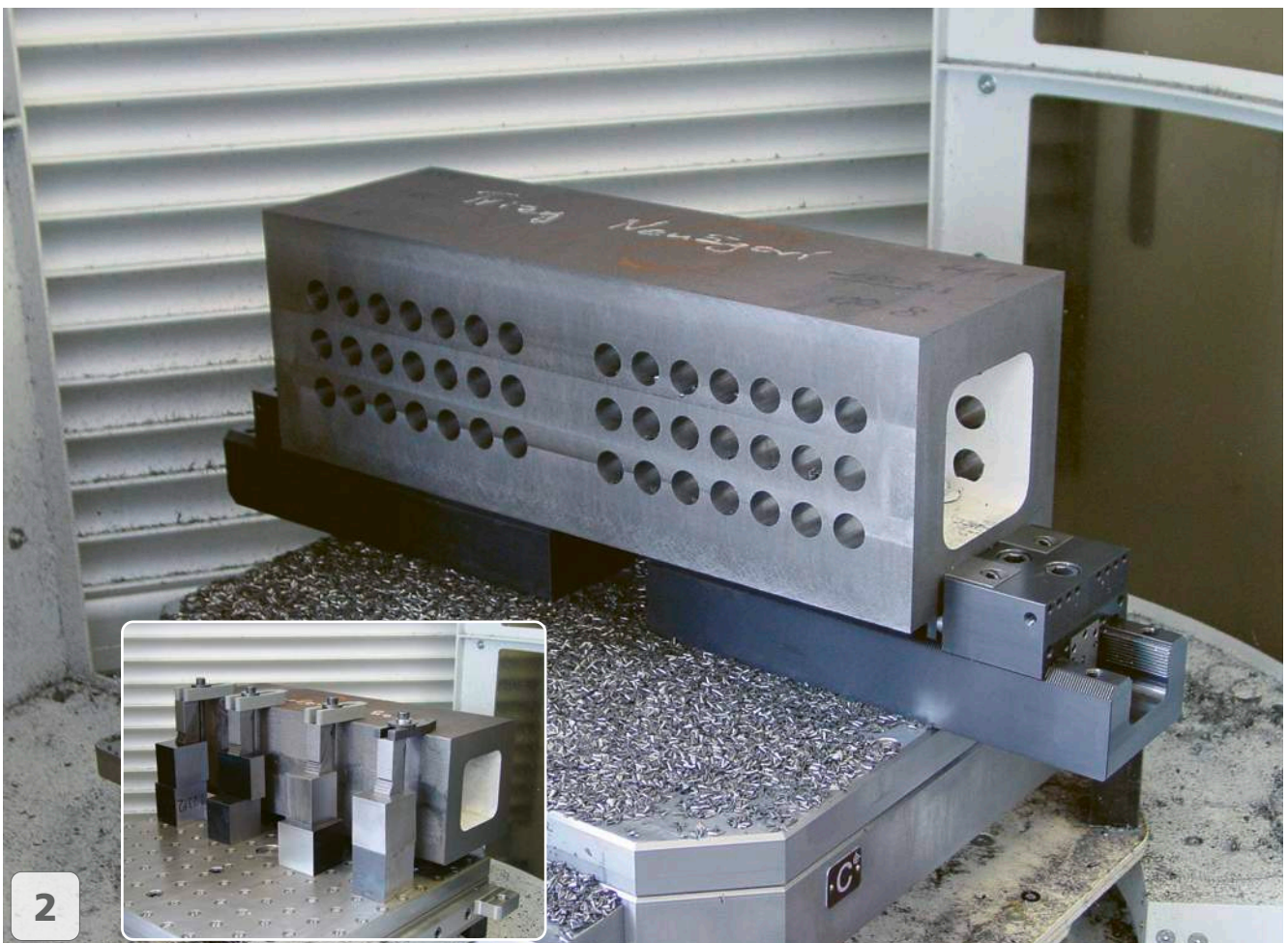
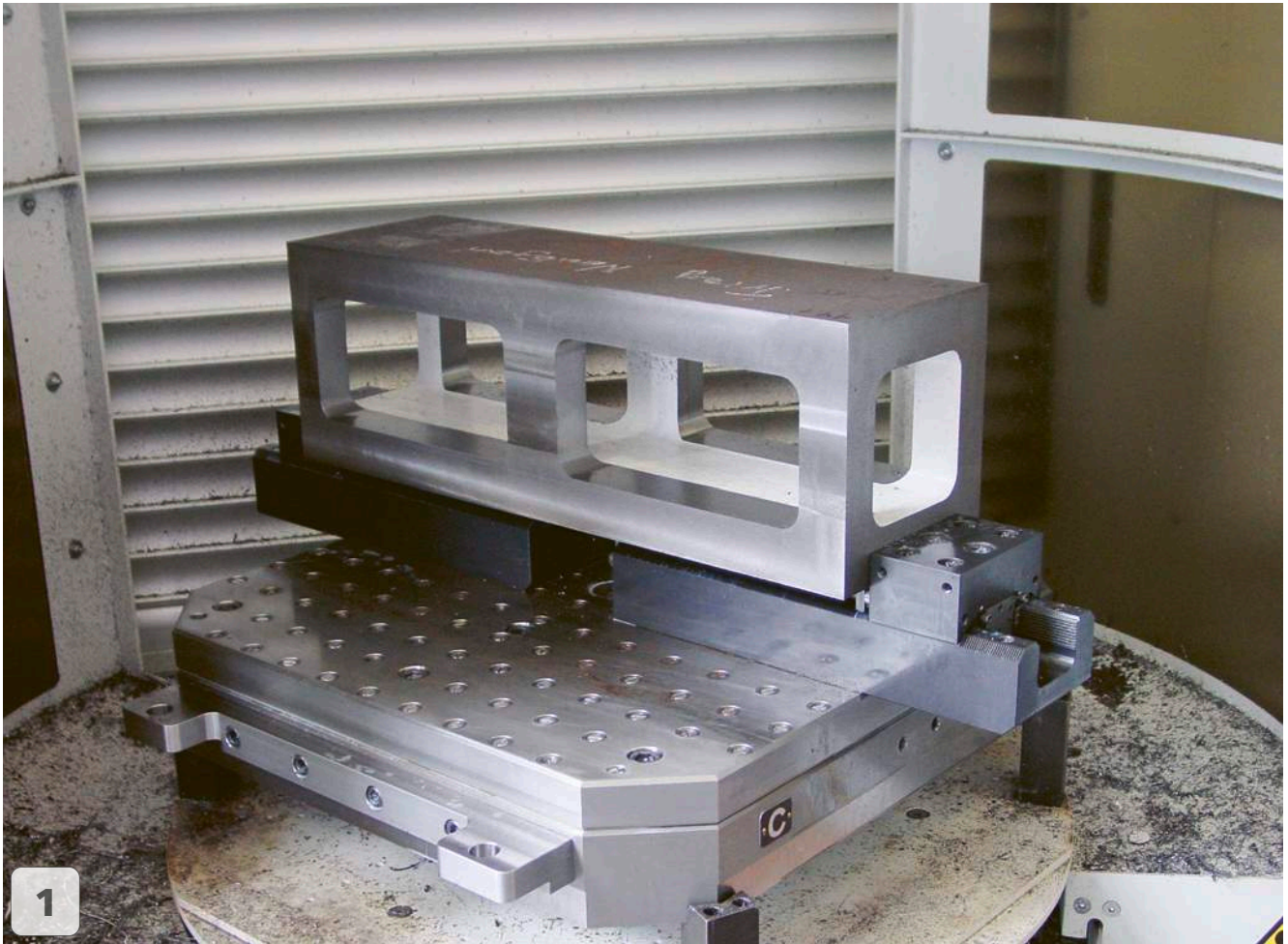

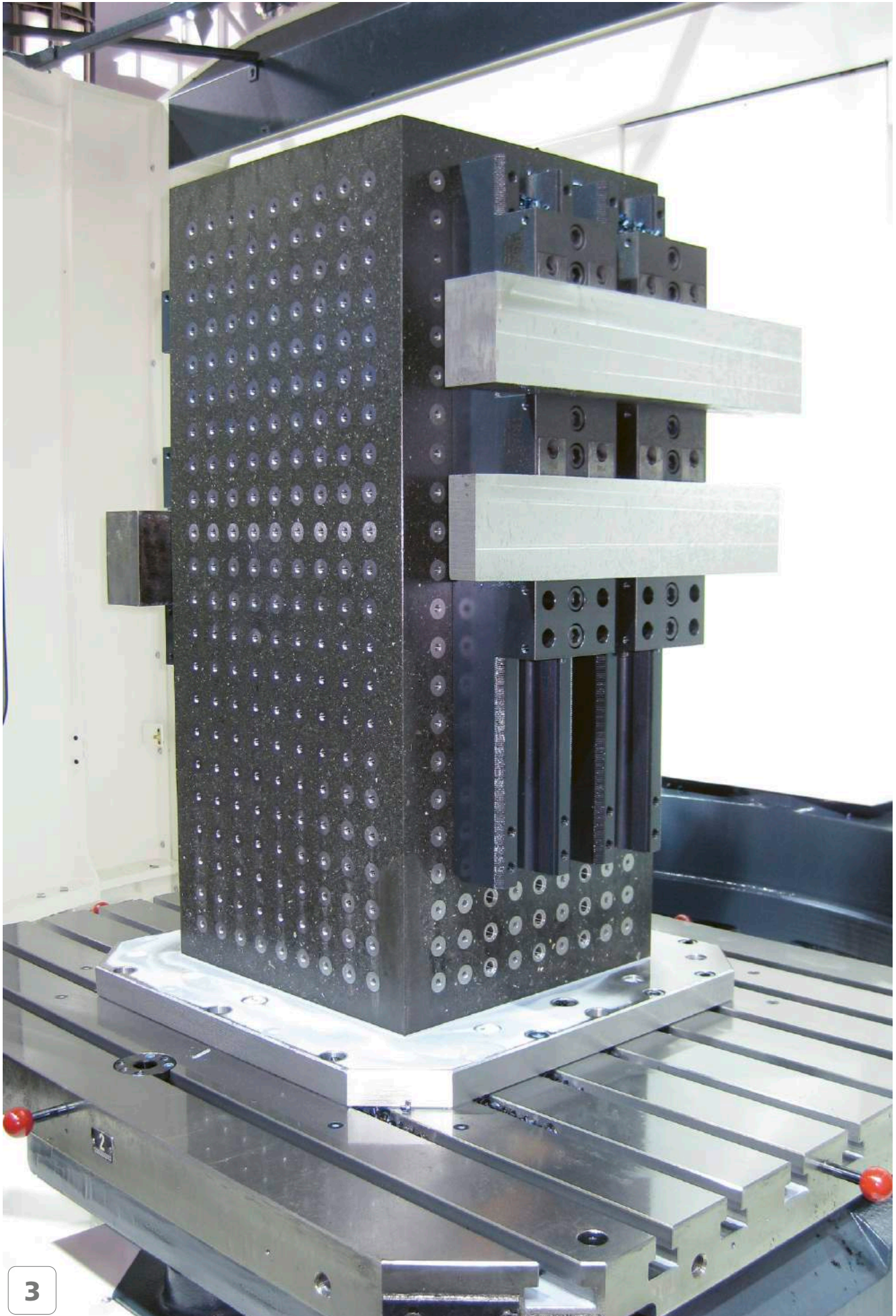

3

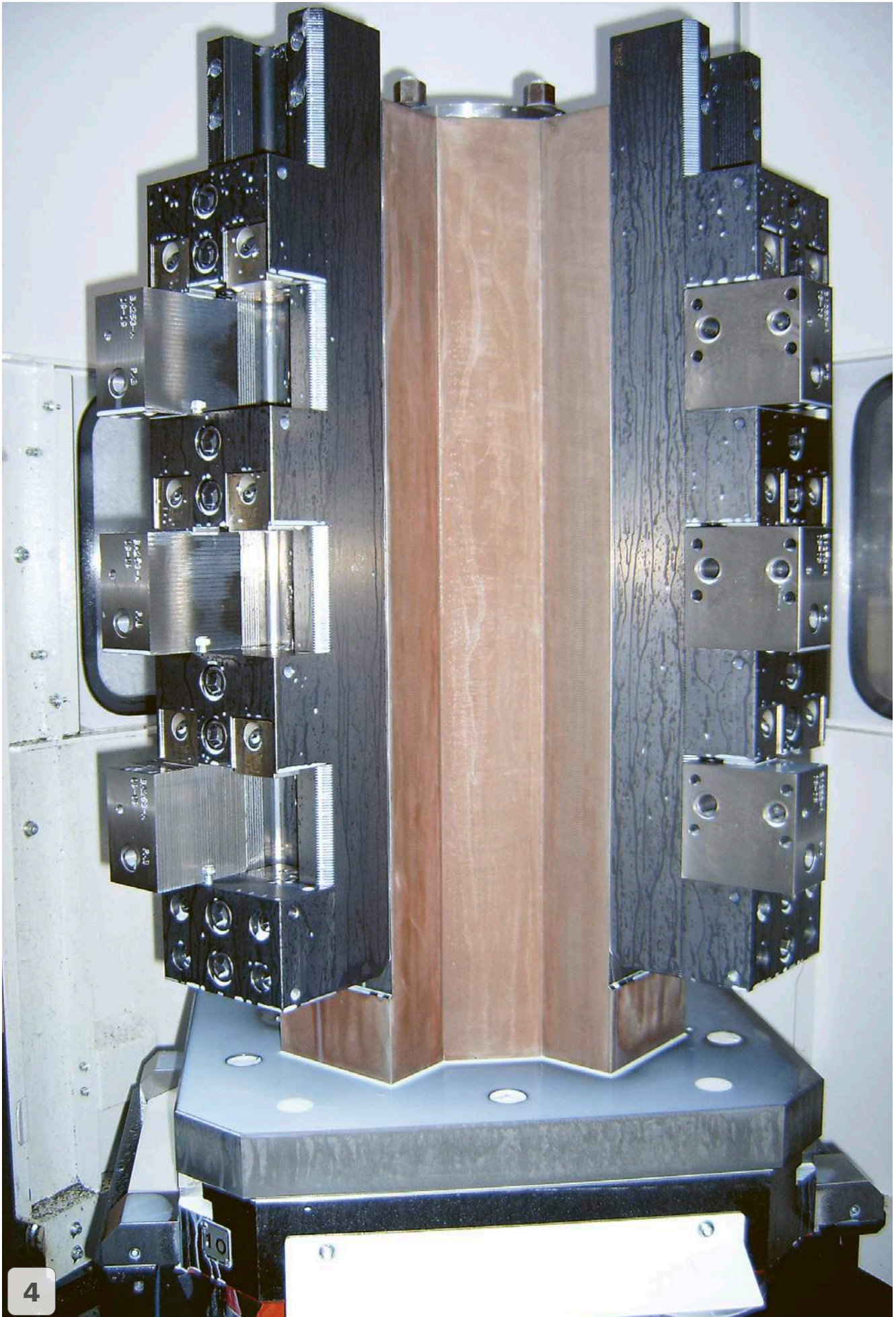

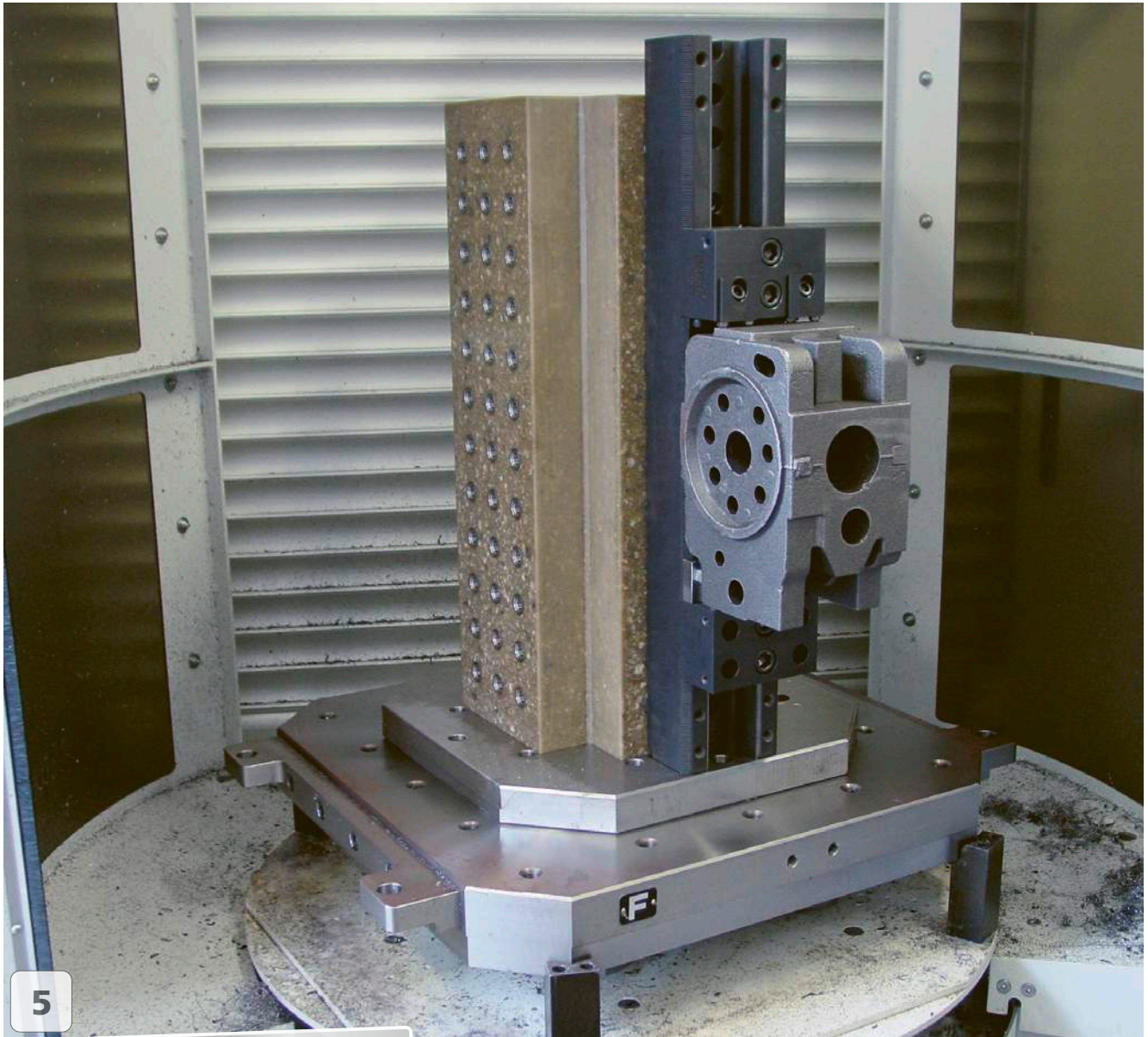

5

VERTICAL (3-4 ACHSEN/AXES)

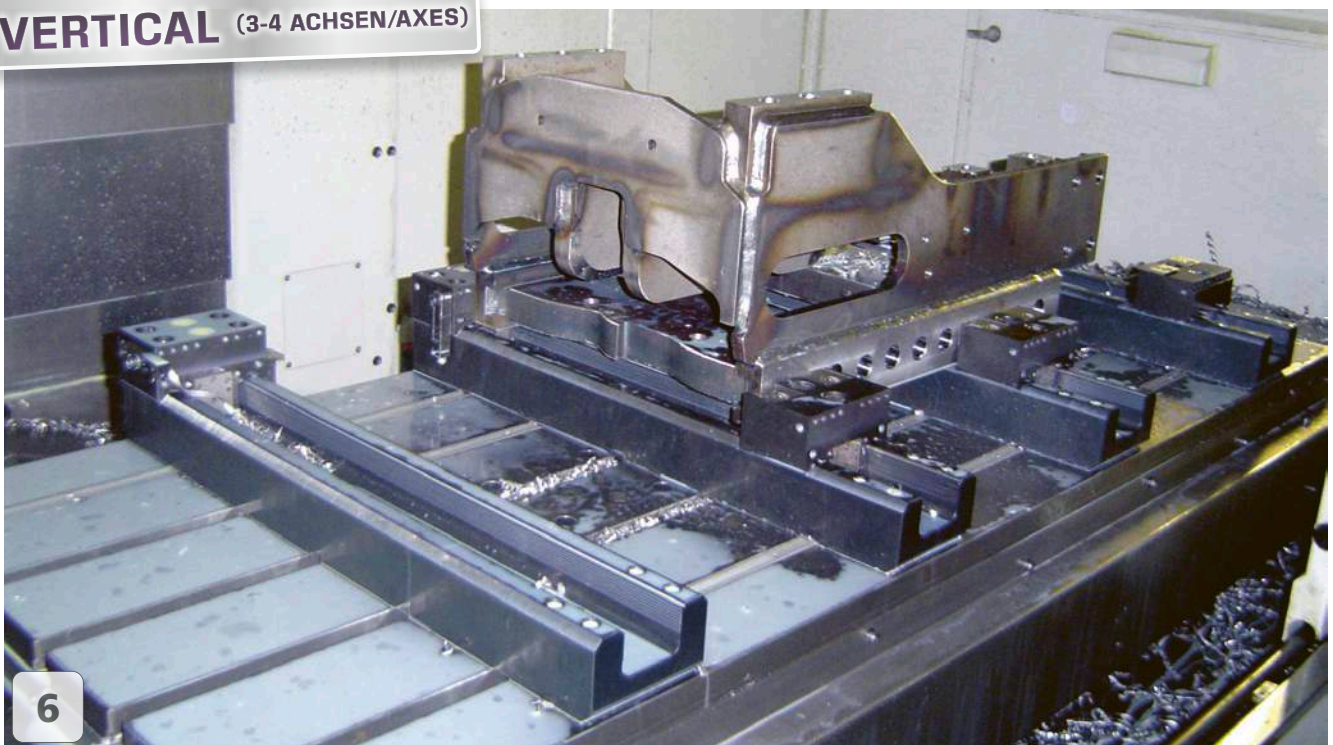

6

Es gibt zusätzlich Apto Clamp Module in angeschrägter Ausführung. Damit kann ein optimaler Zugang zum Werkstück bei der 5-Achsenmaschine gewährleistet werden. Die Spannmodule produzieren bis zu 7000daN (7 Tonnen) Spannkraft und sind für die Schwerzerspannung empfohlen.

We offer Apto Clamp modules in slanted version. That ensures an optimal access to the workpieces on 5-axis machines. The clamping modules produce up to 7000daN (7 tons) clamping force and are recommended for heavy roughing workholding.

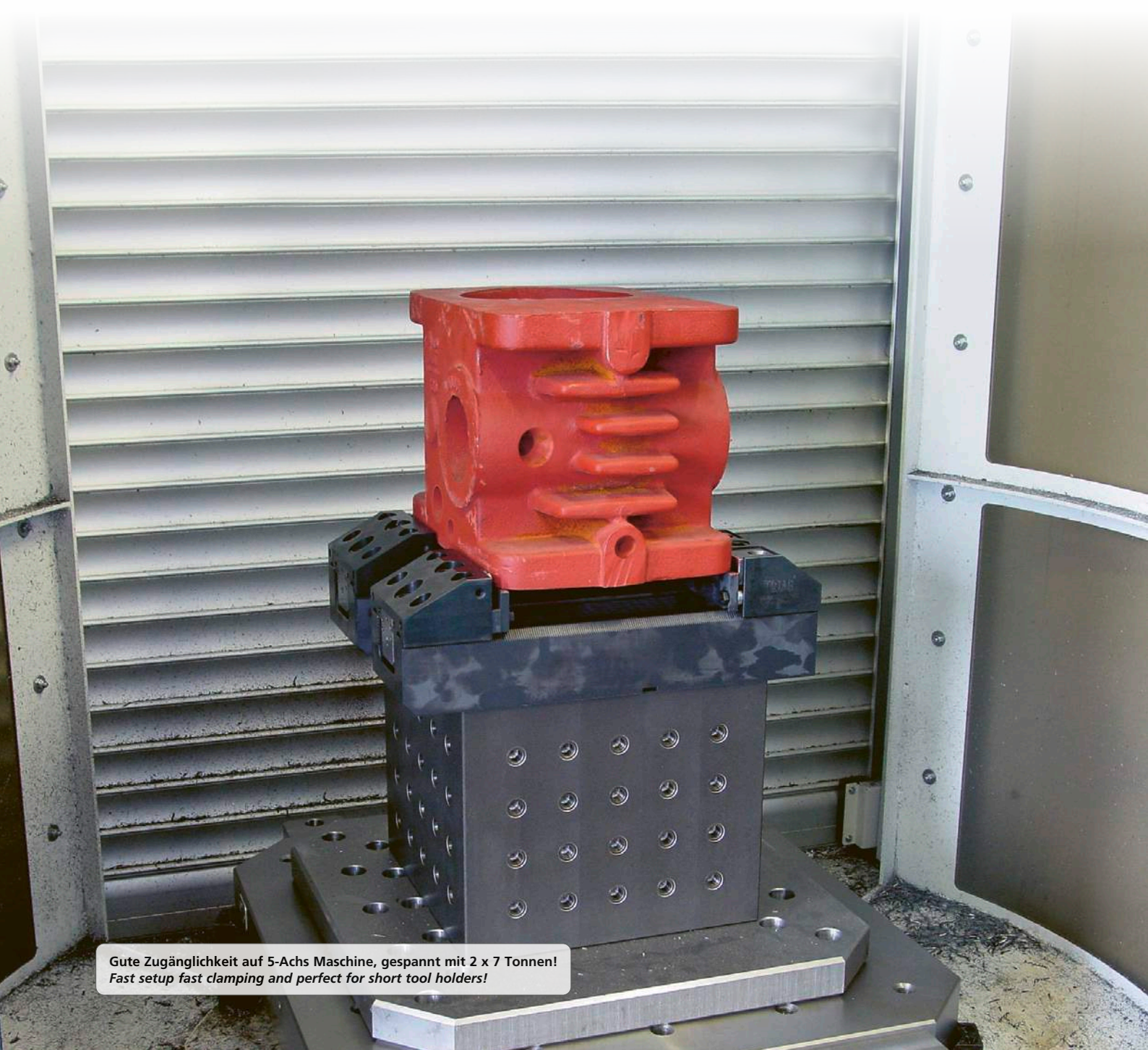

**Gute Zugänglichkeit auf 5-Achs Maschine, gespannt mit 2 x 7 Tonnen!
Fast setup fast clamping and perfect for short tool holders!**

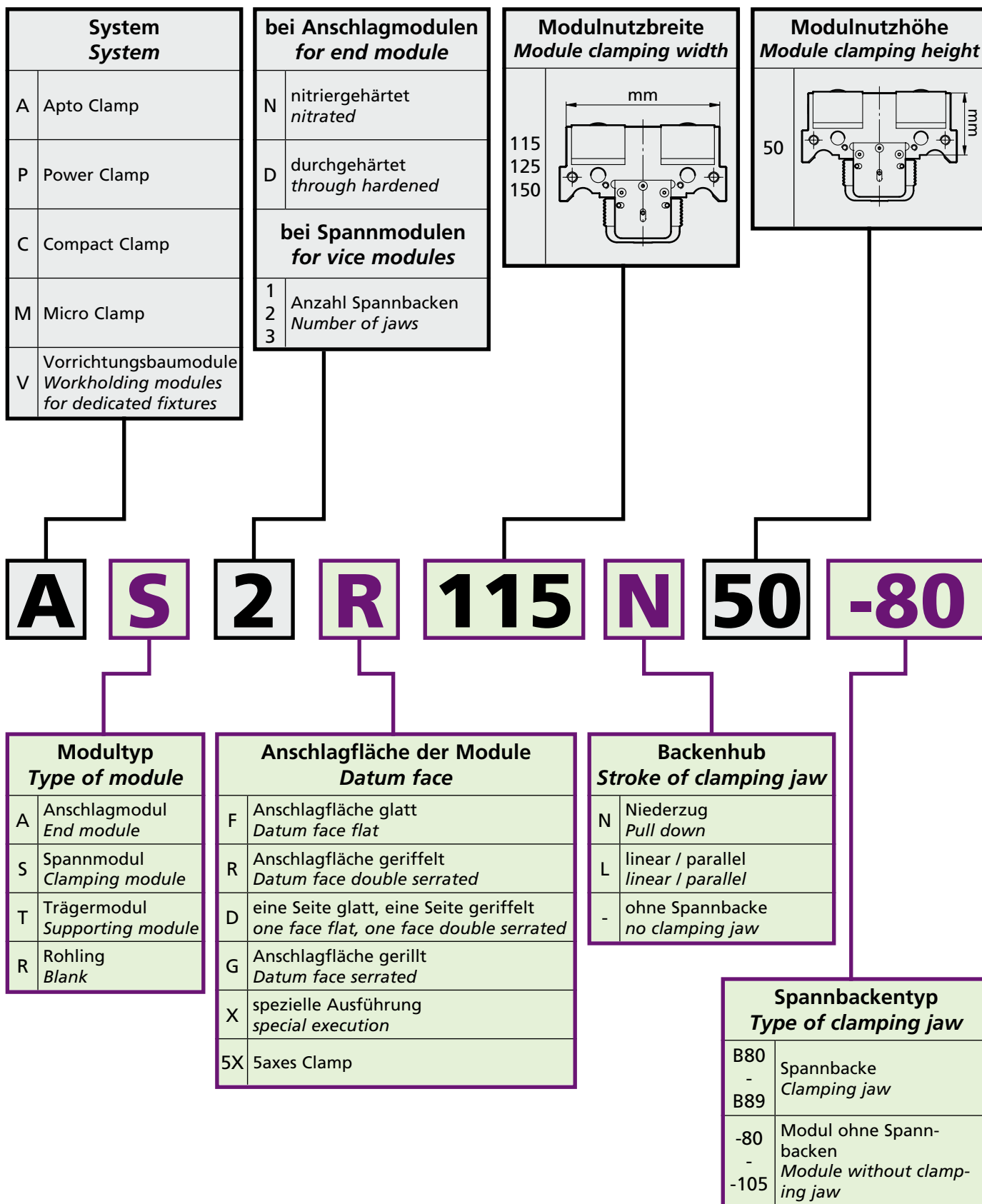

ACB4050400 kg ~18

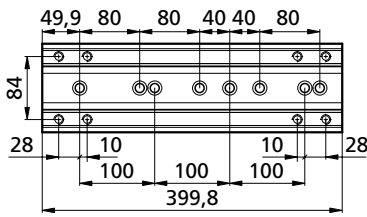

ACB4050700 kg ~31

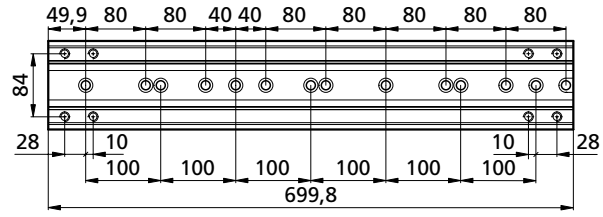

ACB4050450 kg ~20

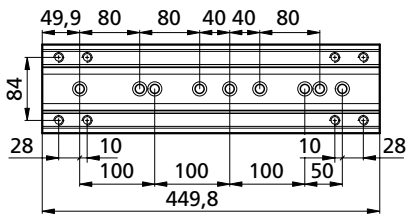

ACB4050750 kg ~33

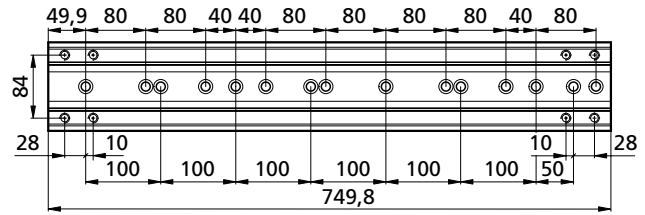

ACB4050500 kg ~22

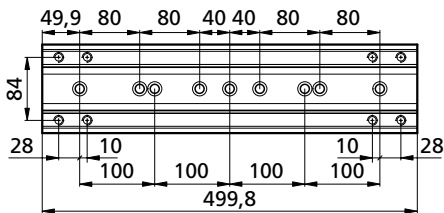

ACB4050800 kg ~35

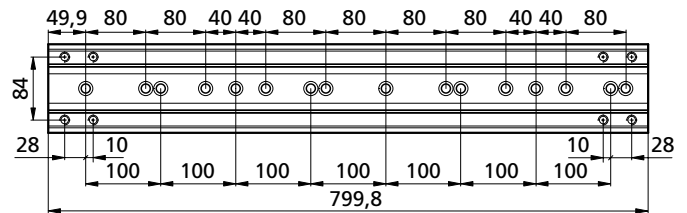

ACB4050550 kg ~24

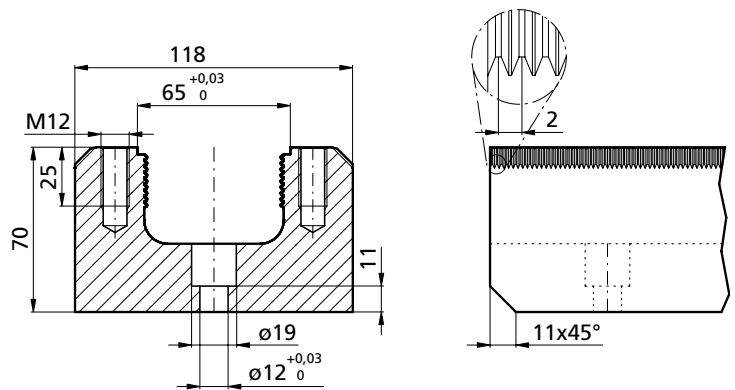
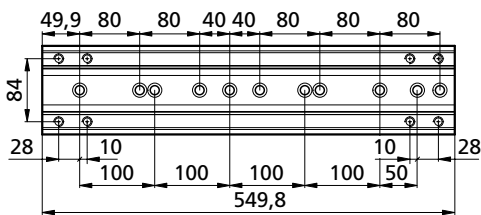

ACB4050600 kg ~26

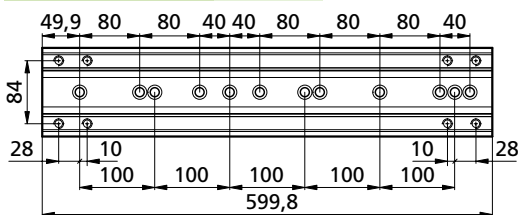

ACB4050650 kg ~29

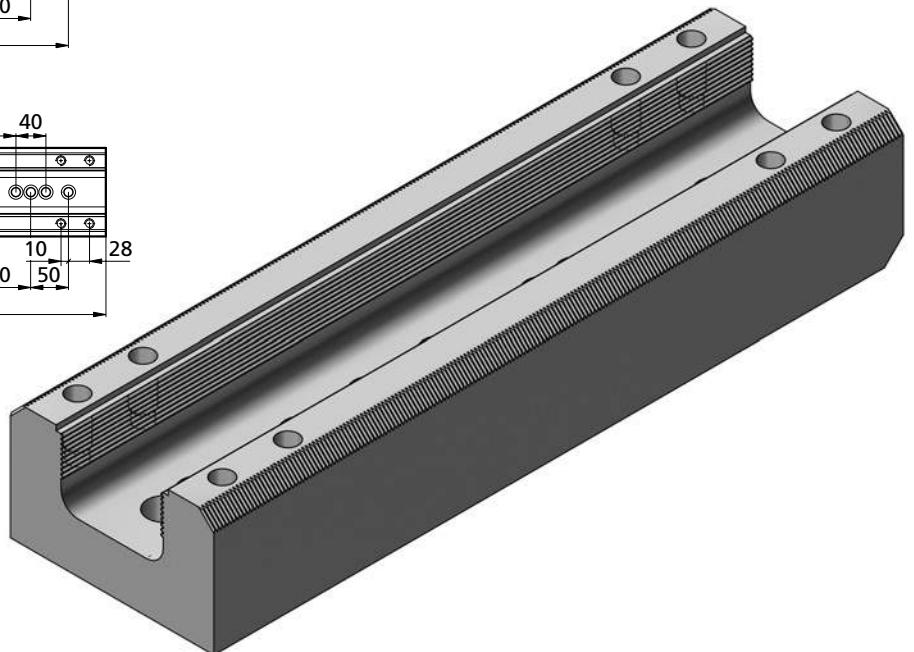
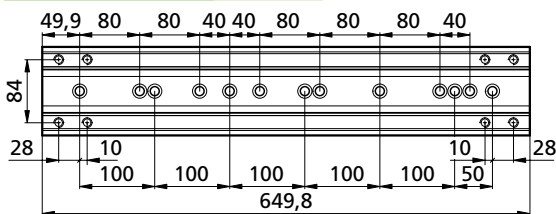

Spannmodule Clamping module

AS2R/F115N50-80
AS25X115N50-80

5axes
aptoCLAMP

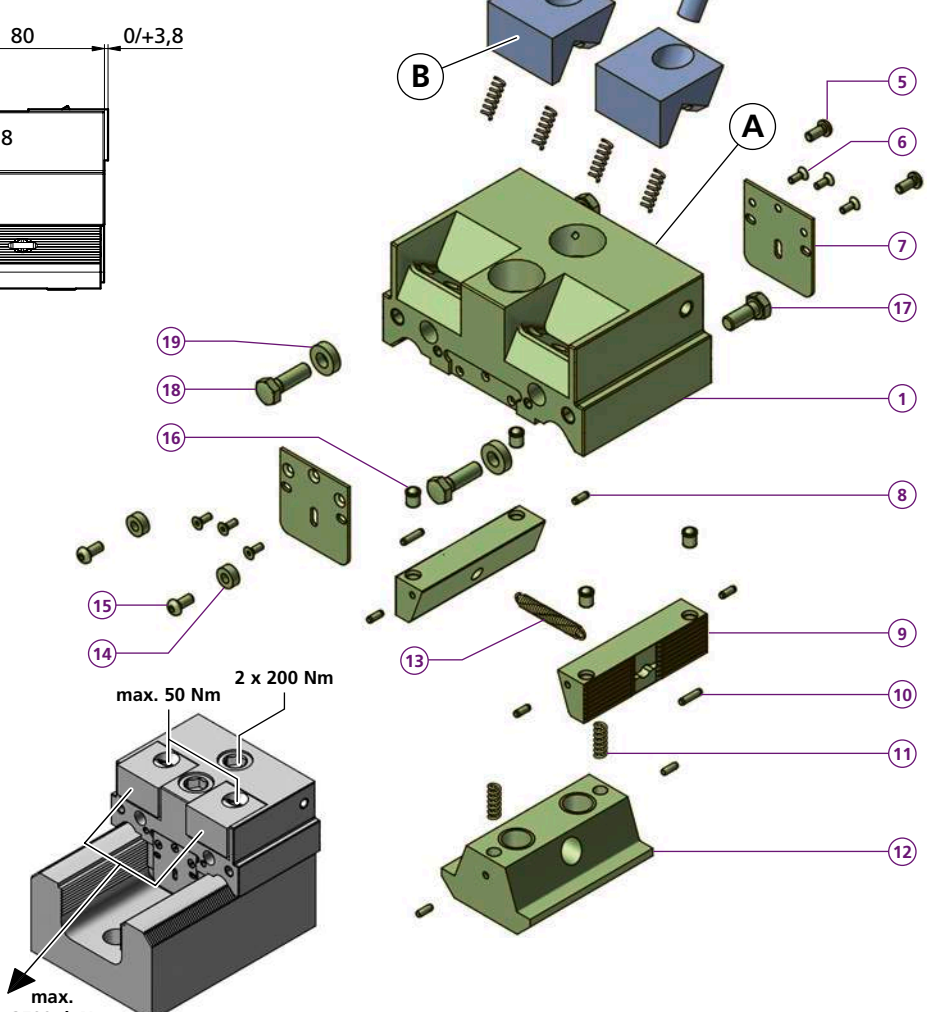
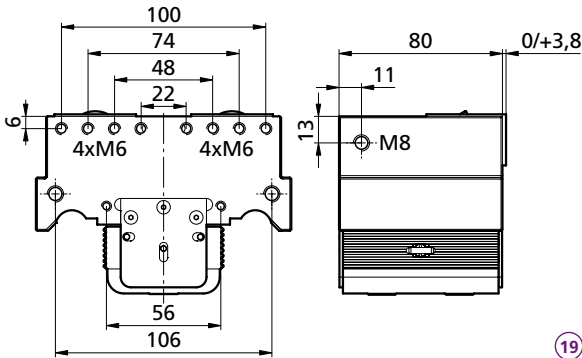
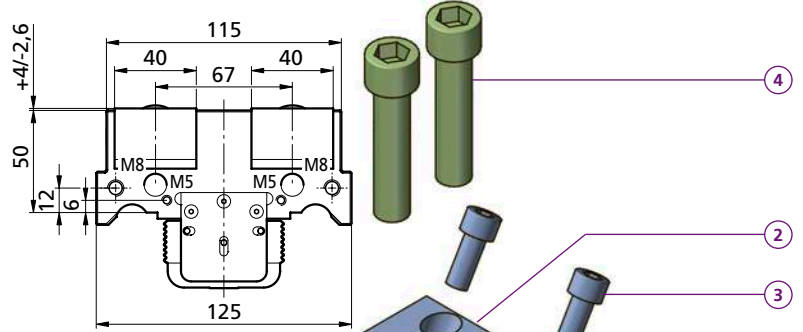
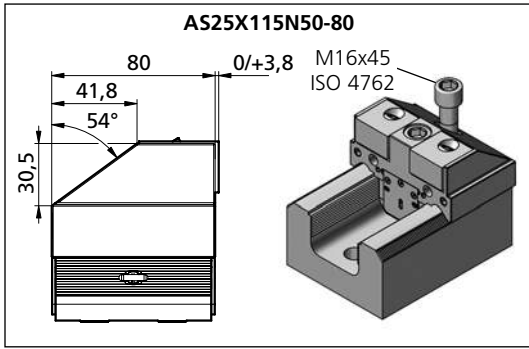

- AS25X115N50-80**
- 1x TF140678
 - 1x M16X45ISO4762
 - 1x M16X70ISO4762
 - 2x M8X20ISO4017
 - 2x ACD005
 - kg ~4,3
- AS2F115N50-80**
- 1x TF140676
- AS2R115N50-80**
- 1x TF140677
 - 2x
 - 2x M10X25ISO4762
 - 2x M16X70ISO4762
 - 2x M5X10ISO7380-1
 - 6x M3X6DIN7991
 - 2x ACBL4243
 - 6x Ø 3x8 VSM 12785
 - 2x ACSP7620
 - 2x Ø 3h 8x12 ISO 2338
 - 6x FED0618
 - 1x ACSK7632M16
 - 1x FED Ø 5,5x39
 - 2x PCD005
 - 2x M5X14ISO7380-1
 - 4x Ø 6-Niro SM1275-3
 - 2x M8X16ISO4017
 - 2x M8X20ISO4017
 - 2x ACD005
 - kg ~4,8

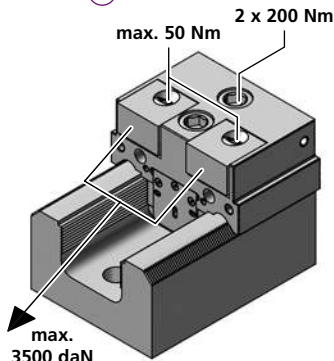

Bestellbeispiel / Ordering example: 1x AS2R115N50-80 & 2x B80

	B80	B80N	B81	B82	B82L33	B82HM	B83	B84	B89F	B89R
C	40	40	40	40	40	40	40	40	40	40
H	25	25	25	25	25	25	25	25	25	25
L	22	22	22	22,2	33	22,2	22	26,3	29	29
D	11	11	11	11	11	11	11	11	11	11
ø	15	15	15	15	15	15	15	15	15	15
i	56HRC	HV700 x0,2mm	56HRC	*	*	56HRC	HV700 x0,2mm	*	HV700 x0,2mm	HV700 x0,2mm
kg	~0,2	~0,2	~0,2	~0,2	~0,28	~0,2	~0,2	~0,2	~0,24	~0,24

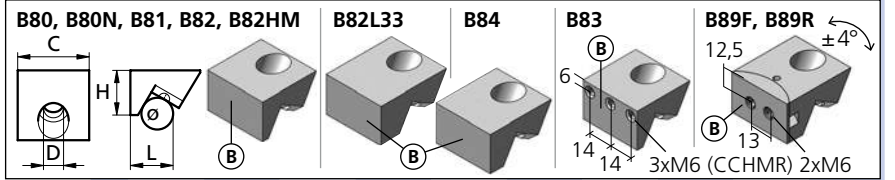

* = weich / soft

HM = Hartmetallbeschichtet / Carbide coated

Separat bestellen / Order separately

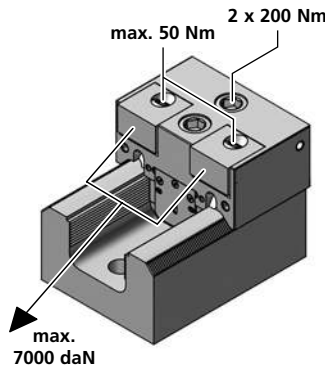
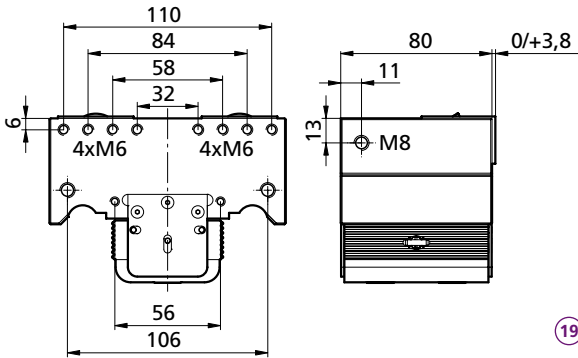
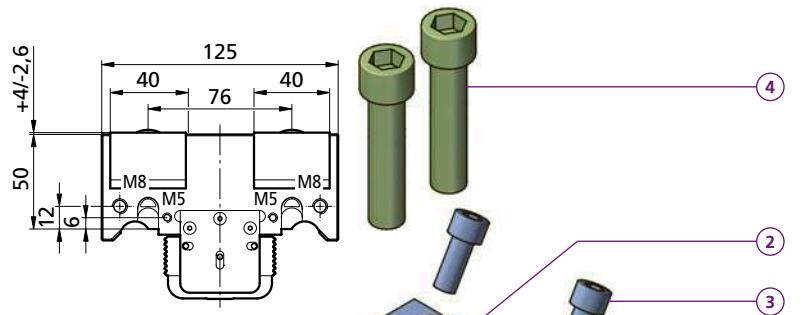
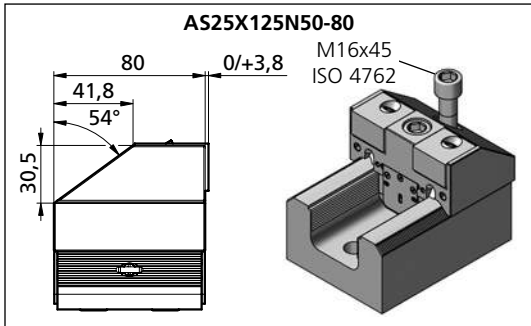

- AS25X125N50-80**
- 1 1x TF140682
 - 4 1x M16X45ISO4762
 - 18 2x M8X20ISO4017
 - 19 2x ACD005
 - kg ~4,3
- AS2F125N50-80**
- 1 1x TF140680
- AS2R125N50-80**
- 1 1x TF140681
 - 2 2x
 - 3 2x M10X25ISO4762
 - 4 2x M16X70ISO4762
 - 5 2x M5X10ISO7380-1
 - 6 6x M3X6DIN7991
 - 7 2x ACBL4243
 - 8 6x Ø 3x8 BN 879
 - 9 2x ACSP7620
 - 10 2x Ø 3h 8x12 ISO 2338
 - 11 6x FED0618
 - 12 1x ACSK7632M16
 - 13 1x FED Ø 5,5x39
 - 14 2x PCD005
 - 15 2x M5X14ISO7380-1
 - 16 4x Ø 6-Niro SM1275-3
 - 17 2x M8X16ISO4017
 - 18 2x M8X20ISO4017
 - 19 2x ACD005
 - kg ~4,9

Bestellbeispiel / Ordering example: 1x AS2R125N50-80 & 2x B80

	B80	B80N	B81	B82	B82L33	B82HM	B83	B84	B89F	B89R
C	40	40	40	40	40	40	40	40	40	40
H	25	25	25	25	25	25	25	25	25	25
L	22	22	22	22,2	33	22,2	22	26,3	29	29
D	11	11	11	11	11	11	11	11	11	11
ø	15	15	15	15	15	15	15	15	15	15
i	56HRC	HV700 x0,2mm	56HRC	*	*	56HRC	HV700 x0,2mm	*	HV700 x0,2mm	HV700 x0,2mm
kg	~0,2	~0,2	~0,2	~0,2	~0,28	~0,2	~0,2	~0,2	~0,24	~0,24

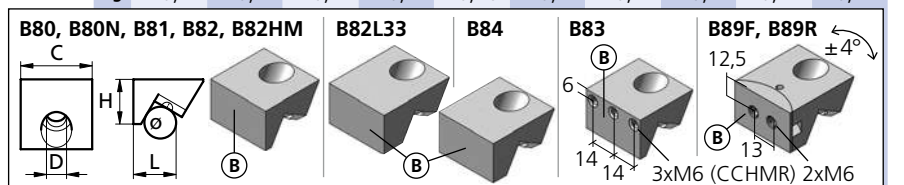

AS2R/F150N50-80
AS25X150N50-80

5axes
aptoCLAMP

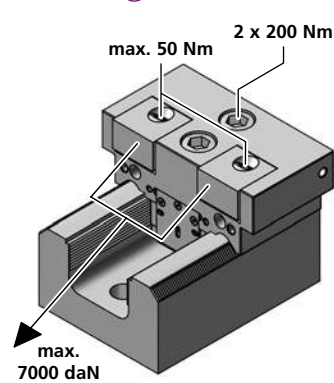
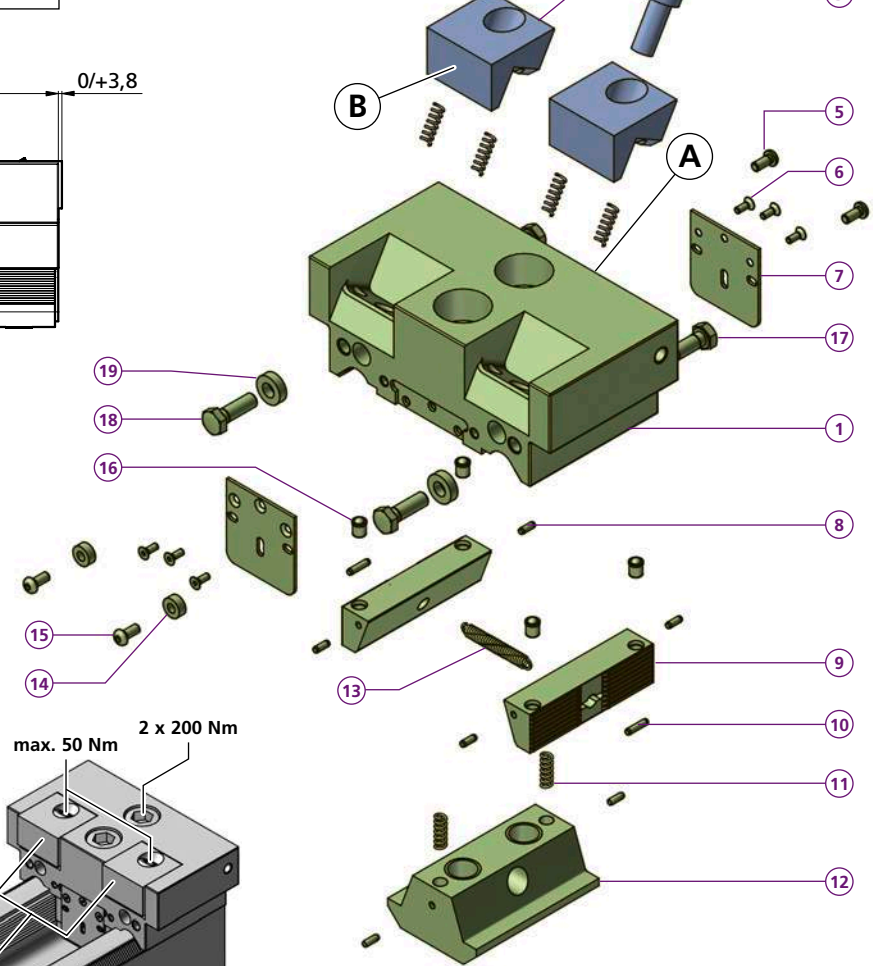
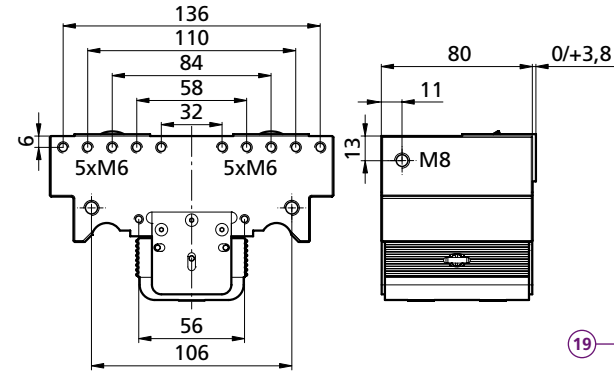
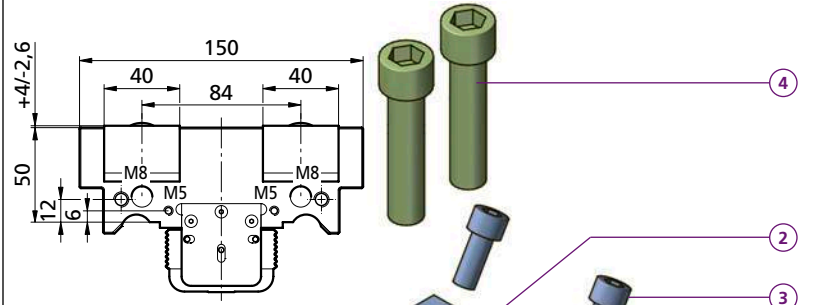
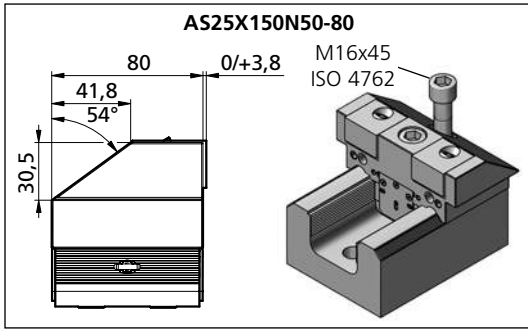

- AS25X150N50-80**
- 1 1x TF140687
 - 4 1x M16X45ISO4762
 - 18 2x M8X20ISO4017
 - 19 2x ACD005
- kg ~4,7
-
- AS2F150N50-80**
- 1 1x TF140685
-
- AS2R150N50-80**
- 1 1x TF140686
 - 2 2x
 - 3 2x M10X25ISO4762
 - 4 2x M16X70ISO4762
 - 5 2x M5X10ISO7380-1
 - 6 6x M3X6DIN7991
 - 7 2x ACBL4243
 - 8 6x Ø 3x8 VSM 12785
 - 9 2x ACSF7620
 - 10 2x Ø 3h 8x12 ISO 2338
 - 11 6x FED0618
 - 12 1x ACSK7632M16
 - 13 1x FED Ø 5,5x39
 - 14 2x PCD005
 - 15 2x M5X14ISO7380-1
 - 16 4x Ø 6-Niro SM1275-3
 - 17 2x M8X16ISO4017
 - 18 2x M8X20ISO4017
 - 19 2x ACD005
- kg ~5,4

Bestellbeispiel / Ordering example: 1x AS2R150N50-80 & 2x B80

	B80	B80N	B81	B82	B82L33	B82HM	B83	B84	B89F	B89R
C	40	40	40	40	40	40	40	40	40	40
H	25	25	25	25	25	25	25	25	25	25
L	22	22	22	22,2	33	22,2	22	26,3	29	29
D	11	11	11	11	11	11	11	11	11	11
e	15	15	15	15	15	15	15	15	15	15
i	56HRC	HV700 x0,2mm	56HRC	*	*	56HRC	HV700 x0,2mm	*	HV700 x0,2mm	HV700 x0,2mm
kg	~0,2	~0,2	~0,2	~0,2	~0,28	~0,2	~0,2	~0,2	~0,24	~0,24

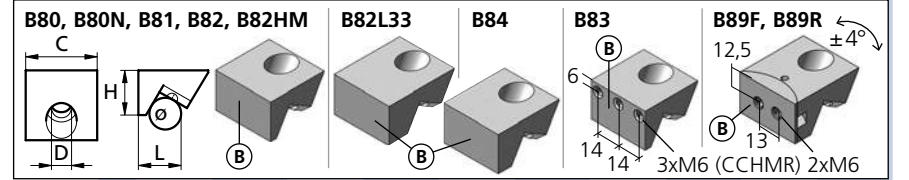

* = weich / soft

HM = Hartmetallbeschichtet / Carbide coated

Separat bestellen / Order separately

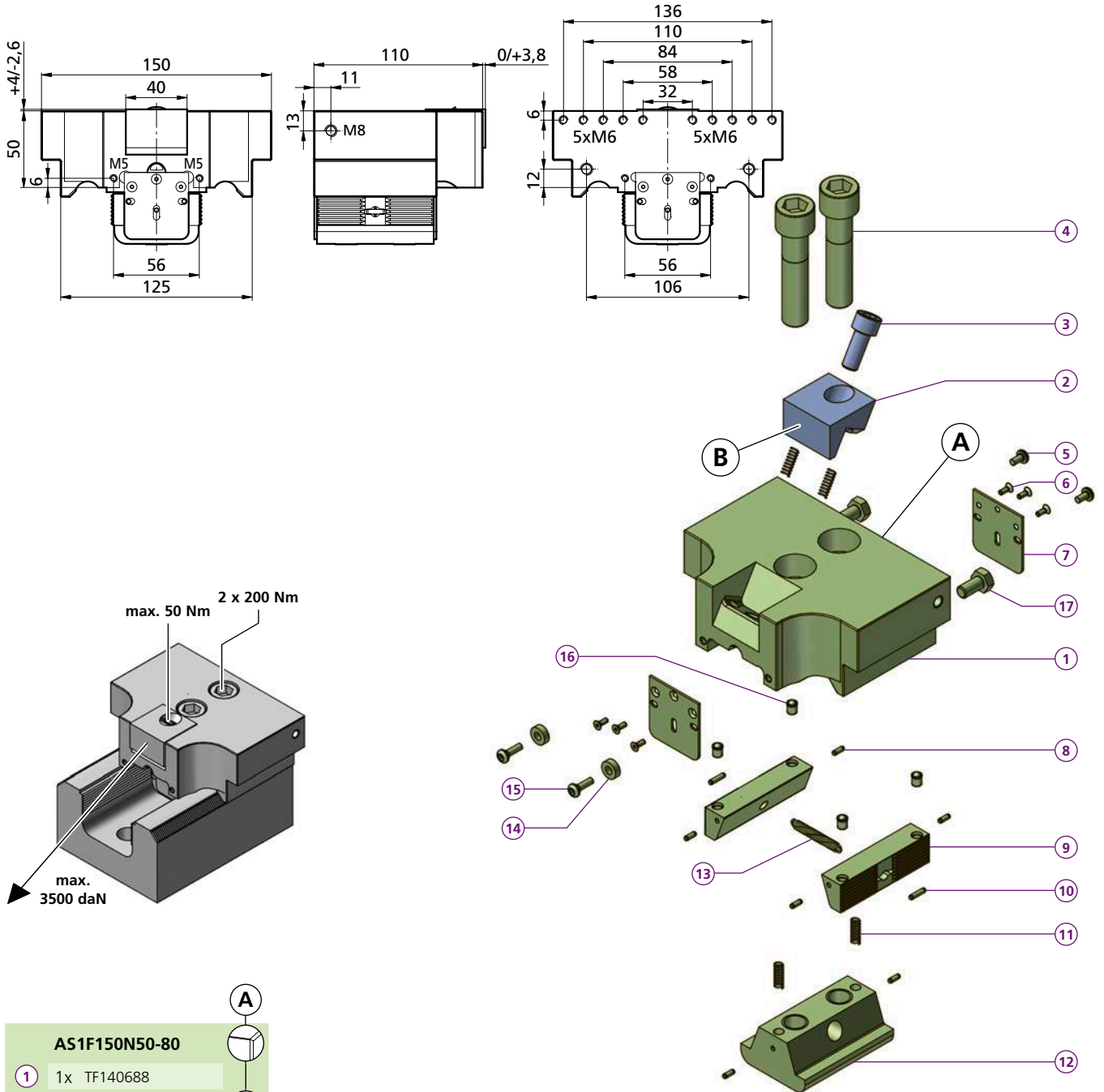

- AS1F150N50-80**
- 1x TF140688
- AS1R150N50-80**
- 1x TF140689
- 2x [Component 2]
- 1x **M10X25ISO4762**
- 2x **M16X70ISO4762**
- 2x **M5X10ISO7380-1**
- 6x M3X6DIN7991
- 2x ACBL4243
- 6x Ø 3x8 VSM 12785
- 2x ACSP7620
- 2x Ø 3h 8x12 ISO 2338
- 4x **FED0618**
- 1x ACSK7632M16
- 1x FED Ø 5,5x39
- 2x **PCD005**
- 2x **M5X14ISO7380-1**
- 4x Ø 6-Niro SM1275-3
- 2x M8X16ISO4017
- kg ~6,6

Bestellbeispiel / Ordering example: 1x AS1R150N50-80 & 1x B80

	B80	B80N	B81	B82	B82L33	B82HM	B83	B84	B89F	B89R
C	40	40	40	40	40	40	40	40	40	40
H	25	25	25	25	25	25	25	25	25	25
L	22	22	22	22,2	33	22,2	22	26,3	29	29
D	11	11	11	11	11	11	11	11	11	11
e	15	15	15	15	15	15	15	15	15	15
i	56HRC	HV700 x0,2mm	56HRC	*	*	56HRC	HV700 x0,2mm	*	HV700 x0,2mm	HV700 x0,2mm
kg	~0,2	~0,2	~0,2	~0,2	~0,28	~0,2	~0,2	~0,2	~0,24	~0,24

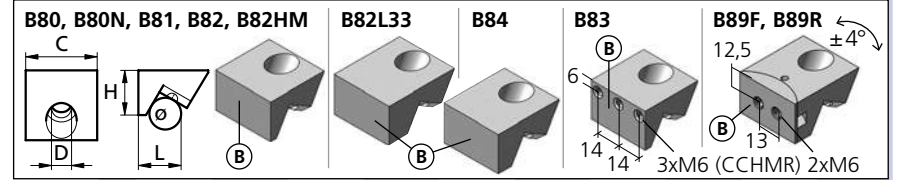

AS2X125L50-105 AS25X125L50-105

5axes aptoCLAMP

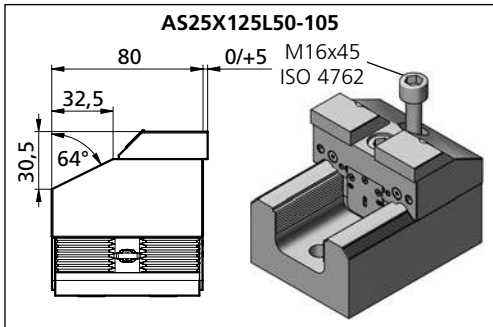
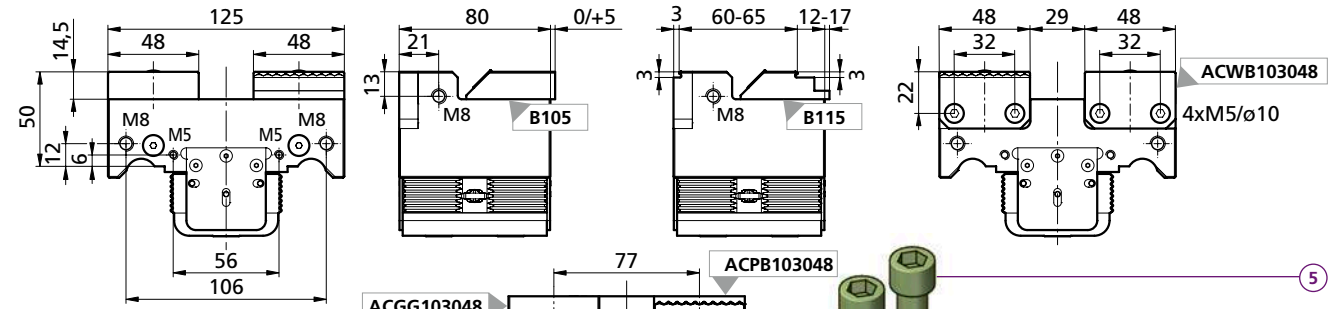

AS25X125L50-105	
1	1x TF140683
4	1x M16X45ISO4762
19	1x M16X55ISO4762
19	2x M8X20ISO4017
20	2x ACD005
kg	~4,3
AS2X125L50-105	
1	1x TF140684
2	2x powerCLAMP p. 85
3	2x M8X30ISO4762
4	2x PCUSR 14
5	2x M16X55ISO4762
6	2x M5X10ISO7380-1
7	6x M3X6DIN7991
8	2x ACBL4243
9	6x Ø 3x8 VSM 12785
10	2x ACSP7620
11	2x Ø 3h 8x12 ISO 2338
12	6x FED0618
13	1x ACSI7632M16
14	1x FED Ø 5,5x39
15	2x PCD005
16	2x M5X14ISO7380-1
17	4x Ø 6-Niro SM1275-3
18	2x M8X16ISO4017
19	2x M8X20ISO4017
20	2x ACD005
21	2x ACGGB103048
22	4x M5X20ISO7380-1
23	4x Ø 5,2 ISO 4247
24	2x M5x10 DIN 7991
25	2x PCKMR45M8
26	4x d=6 DIN 5401
27	2x TS120001
kg	~4,5

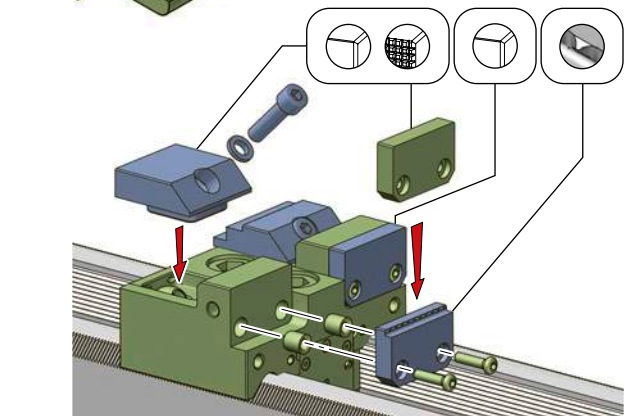
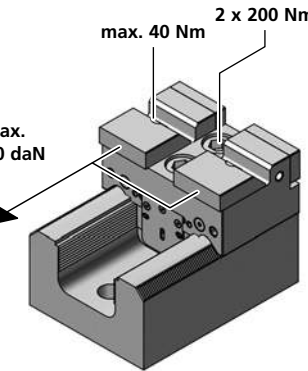
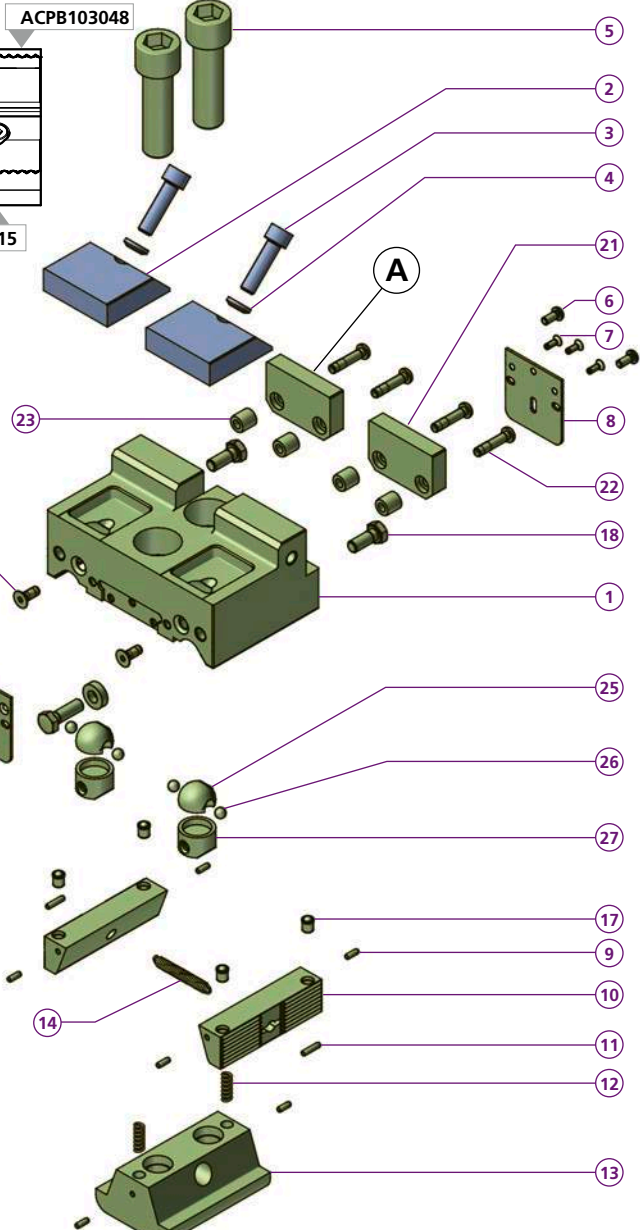
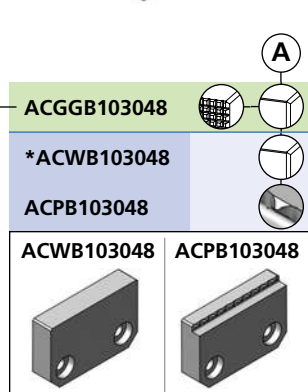
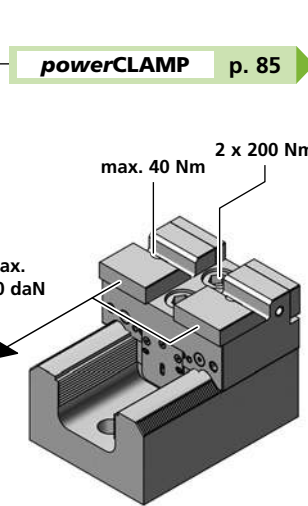
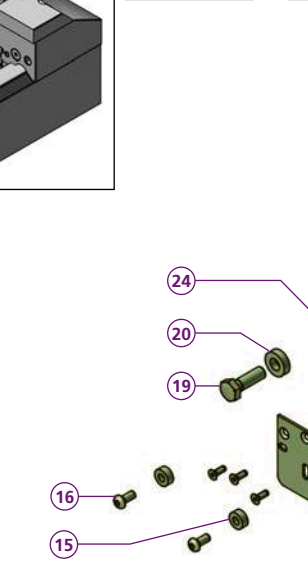
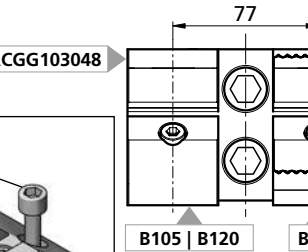

Bestellbeispiel / Ordering example:
1x AS2X125L50-150 & 2x B105 & 2x ACGGB103048

Separat bestellen / Order separately

* = weich / soft

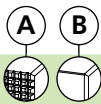
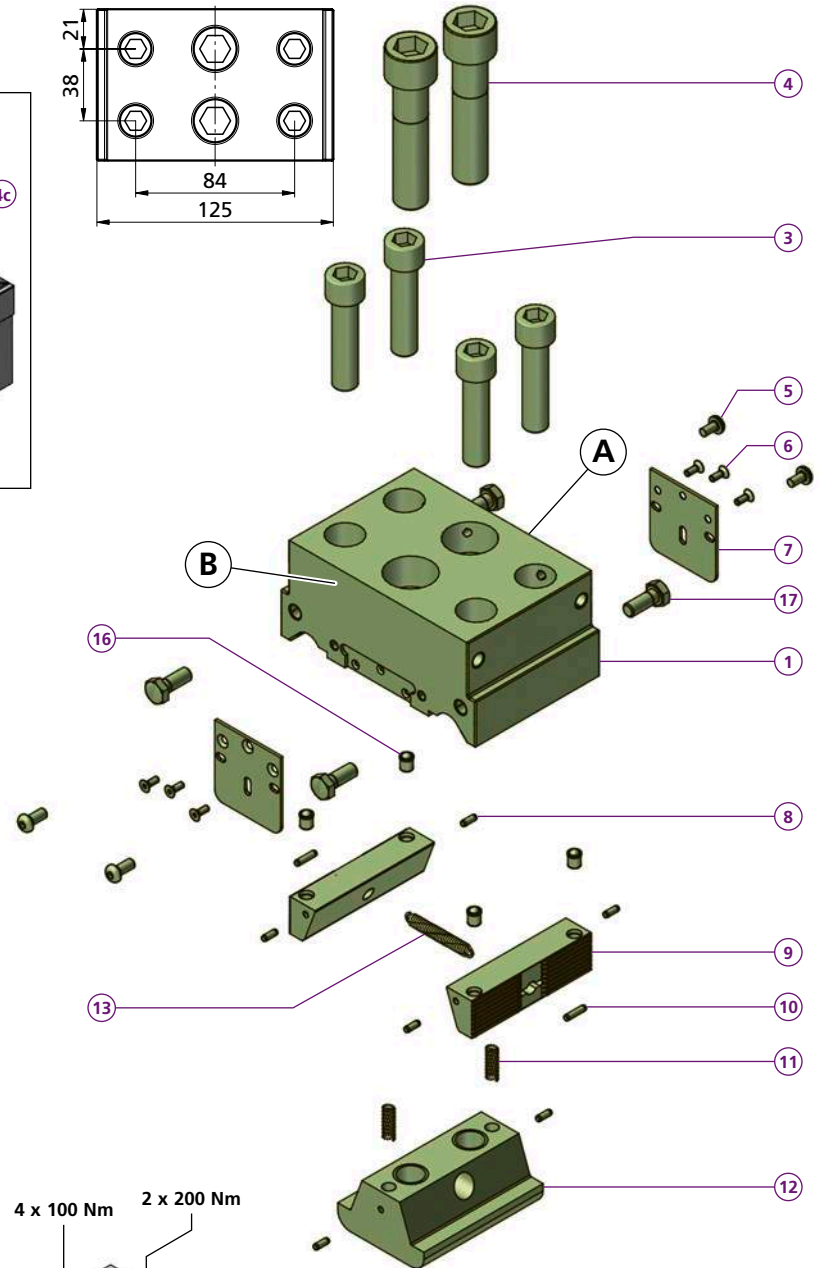
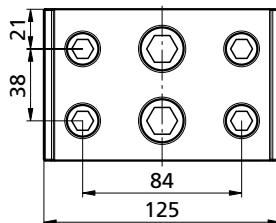
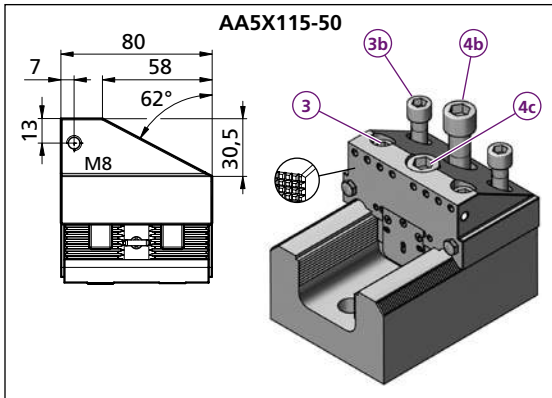
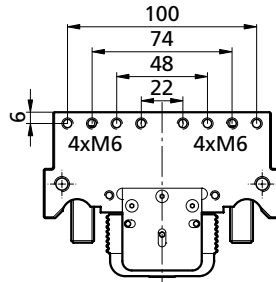
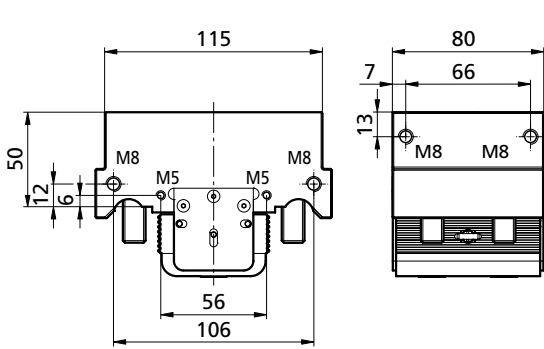

AAND115-50

- 1x TF140690
 - 4x **M12X50ISO4762**
 - 2x **M16X70ISO4762**
 - 4x **M5X10ISO7380-1**
 - 6x M3X6DIN7991
 - 2x ACBL4243
 - 6x \varnothing 3x8 VSM 12785
 - 2x ACS P7620
 - 2x \varnothing 3h 8x12 ISO 2338
 - 2x **FED0618**
 - 1x ACSK7632M16
 - 1x FED \varnothing 5,5x39
 - 4x \varnothing 6-Niro SM1275-3
 - 4x M8X16ISO4017
- kg ~4,7



AA5X115-50

- 1x TF140691
 - 2x **M12X50ISO4762**
 - 2x **M12X30ISO4762**
 - 1x **M16X65ISO4762**
 - 1x **M16X45ISO4762**
 - 2x **M5X10ISO7380-1**
 - 2x M8X16ISO4017
- kg ~4,6

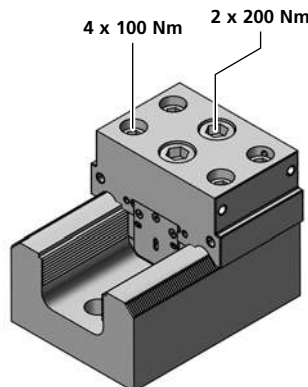

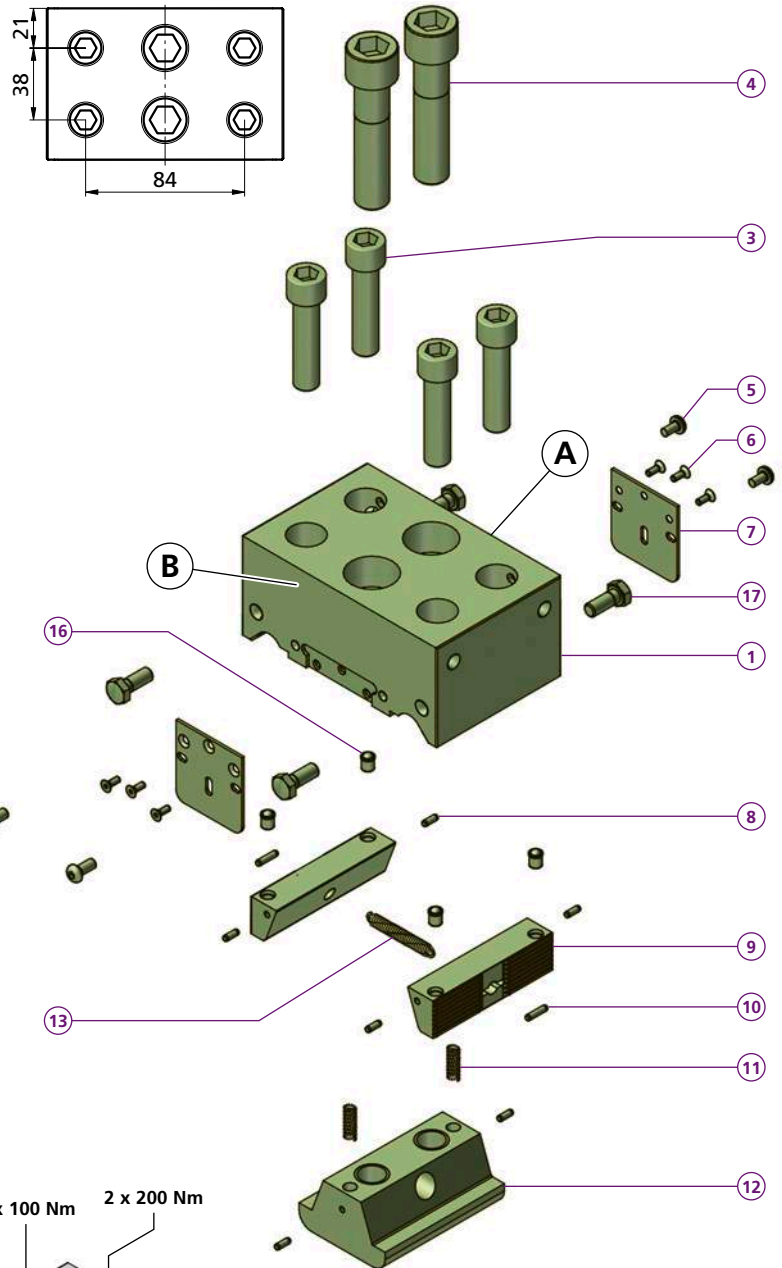
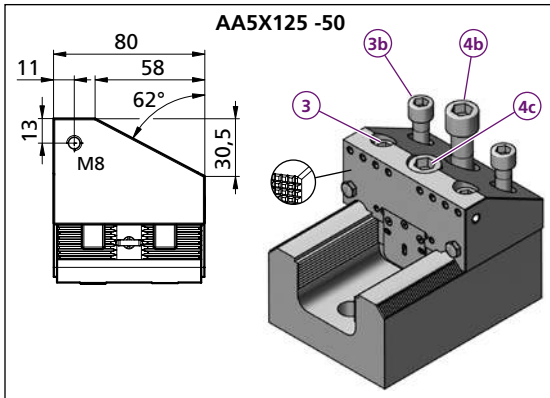
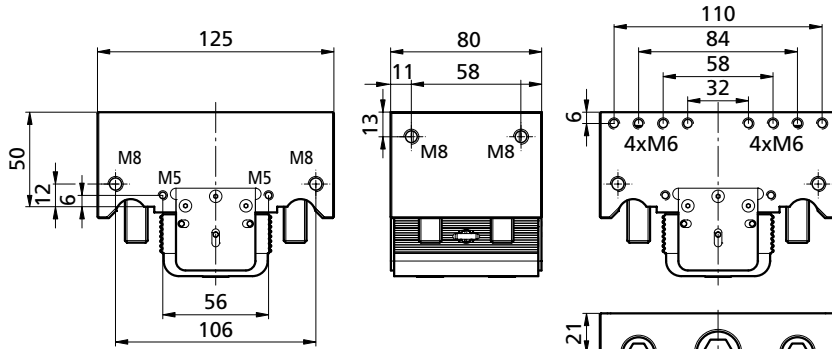

AAND125-50	
1	1x TF140692
3	4x M12X50ISO4762
4	2x M16X70ISO4762
5	4x M5X10ISO7380-1
6	6x M3X6DIN7991
7	2x ACBL4243
8	6x Ø 3x8 VSM 12785
9	2x ACSF7620
10	2x Ø 3h 8x12 ISO 2338
11	2x FED0618
12	1x ACSK7632M16
13	1x FED Ø 5,5x39
16	4x Ø 6-Niro SM1275-3
17	4x M8X16ISO4017
kg	~4,8

AA5X125-50	
1	1x TF140693
3	2x M12X50ISO4762
3b	2x M12X30ISO4762
4c	1x M16X65ISO4762
4b	1x M16X45ISO4762
5	2x M5X10ISO7380-1
17	2x M8X16ISO4017
kg	~4,6

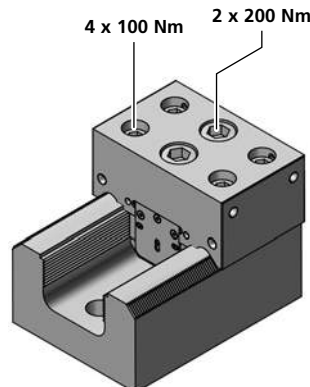

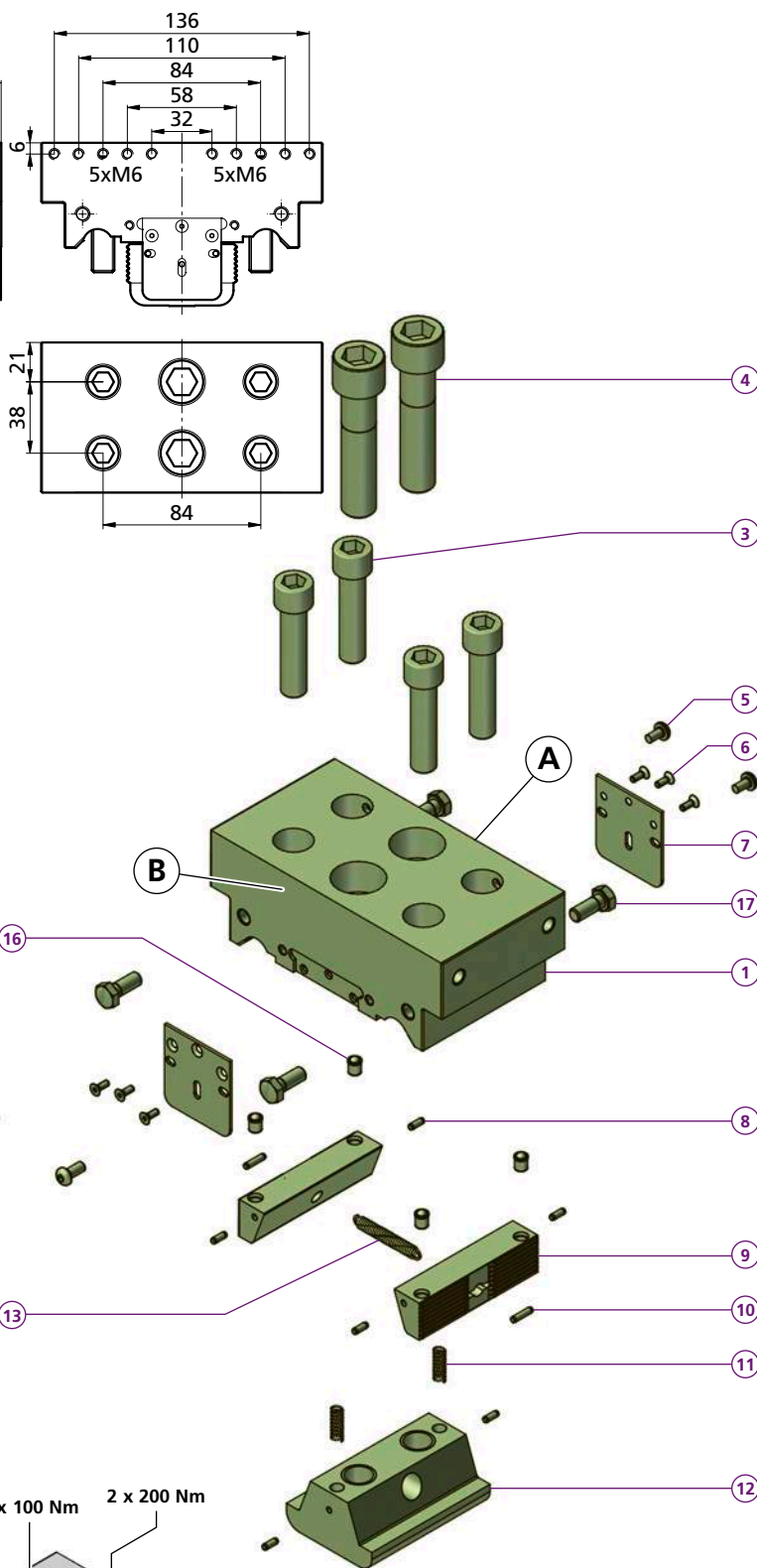
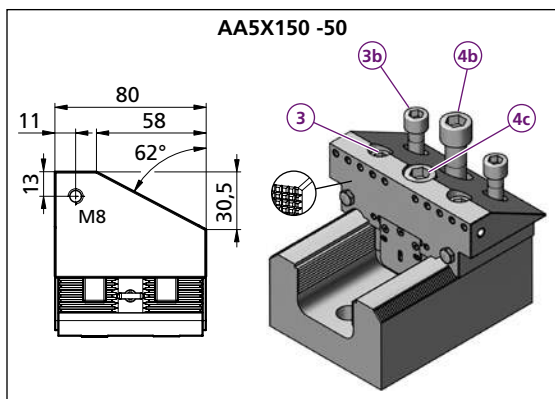
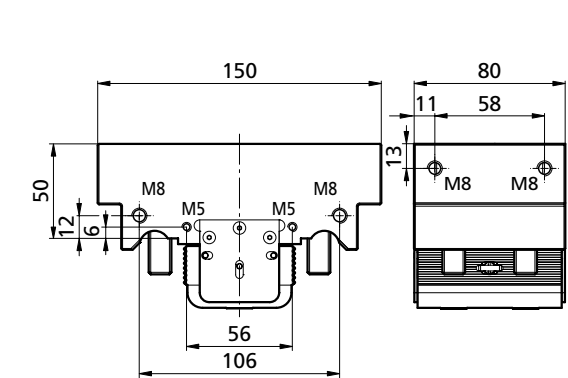

AAND150-50	
1	1x TF140695
3	4x M12X50ISO4762
4	2x M16X70ISO4762
5	4x M5X10ISO7380-1
6	6x M3X6DIN7991
7	2x ACBL4243
8	6x Ø 3x8 VSM 12785
9	2x ACSF7620
10	2x Ø 3h 8x12 ISO 2338
11	2x FED0618
12	1x ACSK7632M16
13	1x FED Ø 5,5x39
16	4x Ø 6-Niro SM1275-3
17	4x M8X16ISO4017
kg	~5,2

AA5X150-50	
1	1x TF140696
3	2x M12X50ISO4762
3b	2x M12X30ISO4762
4c	1x M16X65ISO4762
4b	1x M16X45ISO4762
5	2x M5X10ISO7380-1
17	2x M8X16ISO4017
kg	~5,0

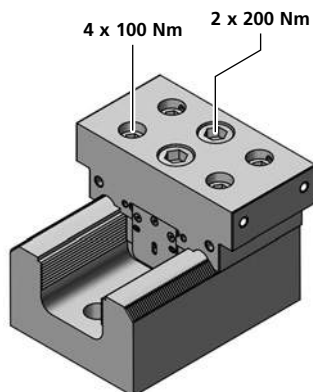

AA5X125-50VB

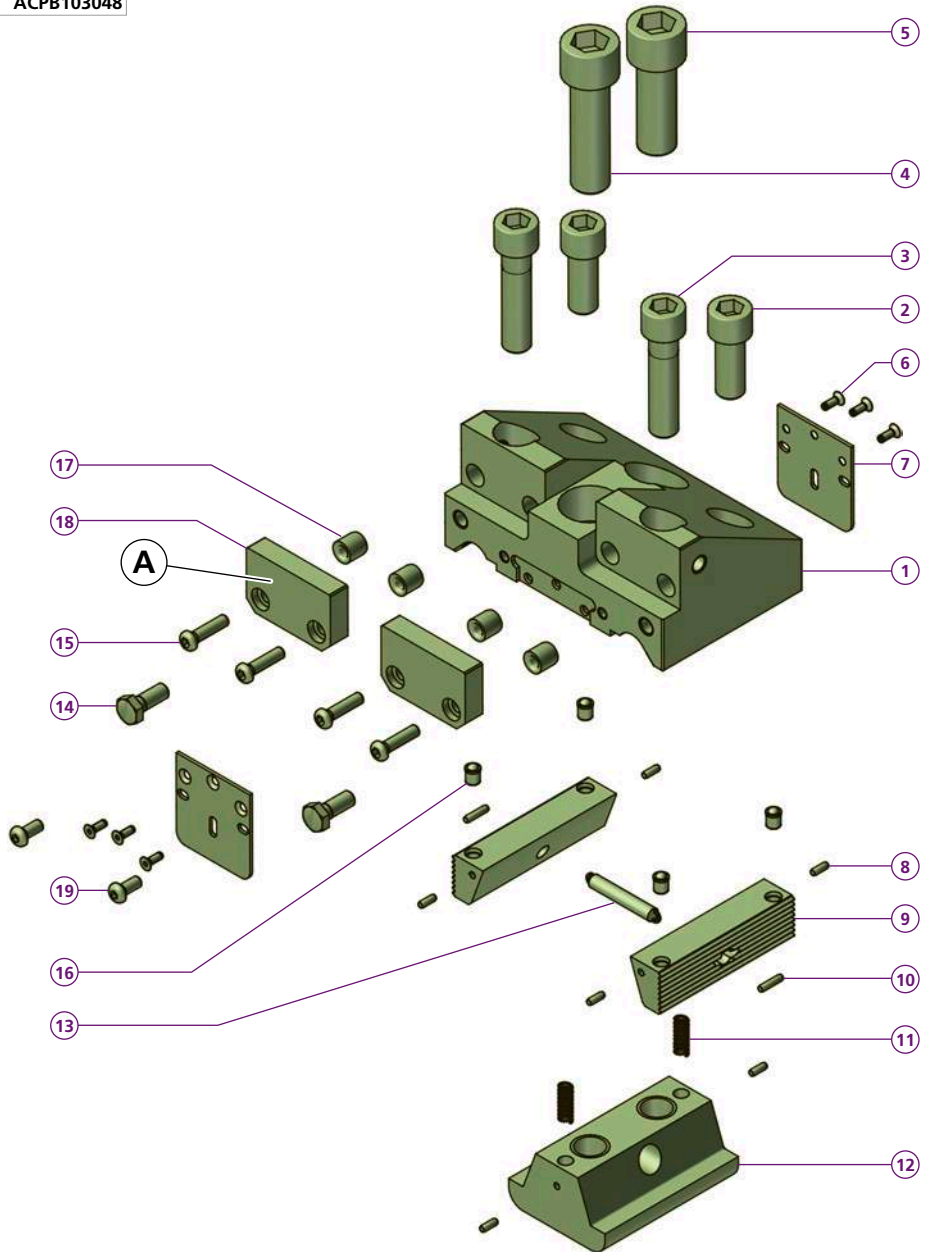
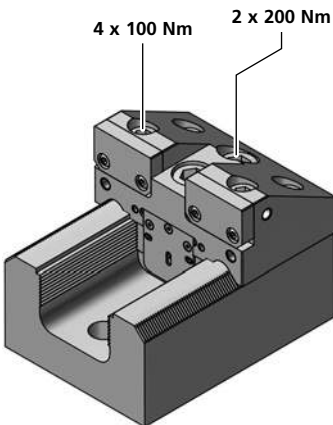
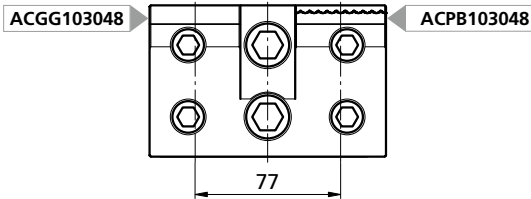
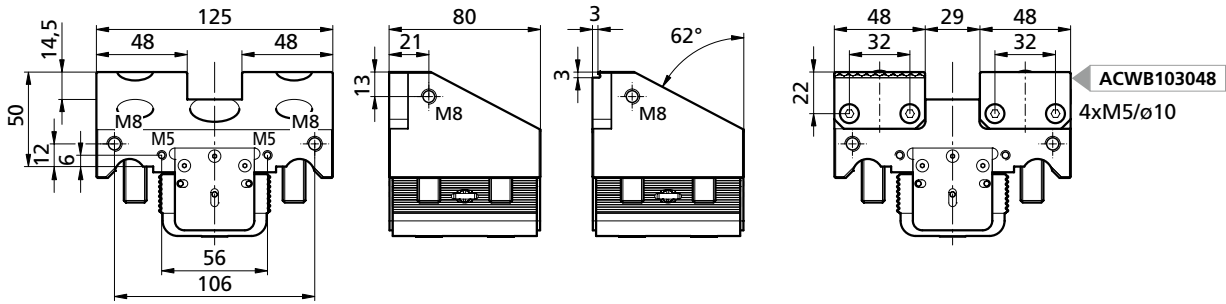

AA5X125-50VB	
1	1x TF140694
2	2x M12X30ISO4762
3	2x M12X50ISO4762
4	1x M16X55ISO4762
5	1x M16X45ISO4762
6	6x M3X6DIN7991
7	2x ACBL4243
8	6x Ø 3x8 VSM 12785
9	2x ACSP7620
10	2x Ø 3h 8x12 ISO 2338
11	2x FED0618
12	1x ACSK7632M16
13	1x FED Ø 5,5x39
14	2x M8X16ISO4017
15	4x M5X20ISO7380-1
16	4x Ø 6-Niro SM1275-3
17	4x 5,2x10x10 DIN179-A
18	2x
19	2x M5X10ISO7380-1
kg	~4,5

ACGGB103048	
*ACWB103048	
ACPB103048	
ACWB103048	
ACPB103048	

Bestellbeispiel / Ordering example:
1x AA5X125-50VB & 2x ACGGB103048

Separat bestellen / Order separately

**Parallelunterlage
Steel parallels**

124mm	B	H	kg
ACU21124	124	21	~0,138
ACU36124	124	36	~0,250
ACU41124	124	41	~0,294
ACU46124	124	46	~0,328

94mm	B	H	kg
PCU14093	93	14	~0,04
PCU20093	93	20	~0,06
PCU24093	93	24	~0,07
PCU29093	93	29	~0,09
PCU31093	93	31	~0,09
PCU34093	93	34	~0,10
PCU39093	93	39	~0,11
PCU44093	93	44	~0,12
PCU46093	93	46	~0,14

125mm	B	H	kg
PCU20124	124	20	~0,08
PCU24124	124	24	~0,09
PCU29124	124	29	~0,11
PCU31124	124	31	~0,12
PCU34124	124	34	~0,13
PCU39124	124	39	~0,15
PCU44124	124	44	~0,17

**Universalnutstein
Universal nut**

ACES6540

- ① 1x ACZS6540
- ② 1x ACEL6540
- ③ 1x M12X30DIN7984
- ④ 2x SM1275-1KSM8

kg ~ 0,67

ACES10240H07

- ① 1x ACZS6540
- ② 1x ACEL6540-07102
- ③ 1x M12X30DIN7984
- ④ 2x SM1275-1KSM8

kg ~ 0,88

ACES10040H25W

- ① 1x ACZS6540
- ② 1x ACEL10040H25W
- ③ 1x M12X30DIN7984
- ④ 2x SM1275-1KSM8

kg ~ 1,42

weich
soft 1.2312

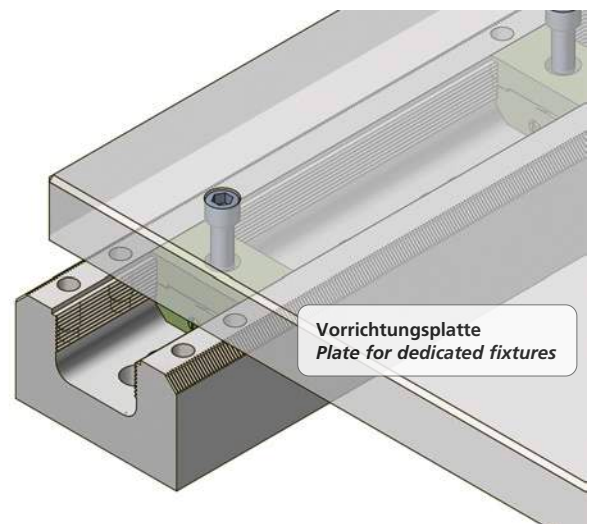

Bestellbeispiel / Ordering example: **ACES6540**

Separat bestellen / Order separately

Universal - Unterlagenhalter

Universal holder for steel parallels

aptoCLAMP

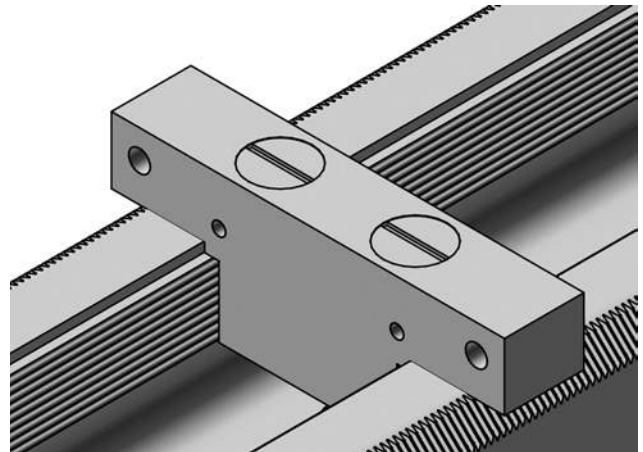
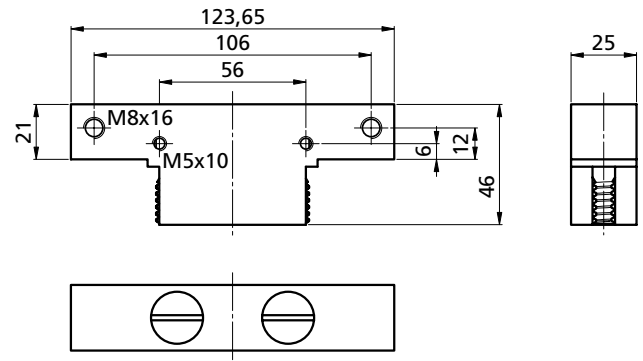
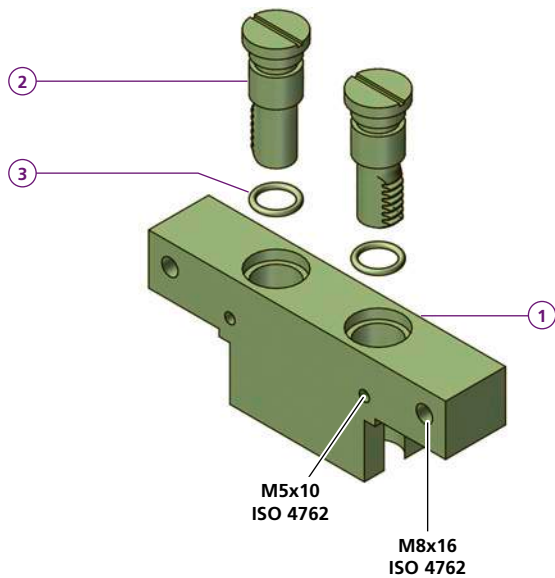

Bestellbeispiel / Ordering example: **ACUH21-124**

ACUH21-124

- ① 1x TW090086-02
 - ② 2x ACBS1646
 - ③ 2x OR Ø 12X2
- kg ~ 0,74

weiche Backe soft jaw

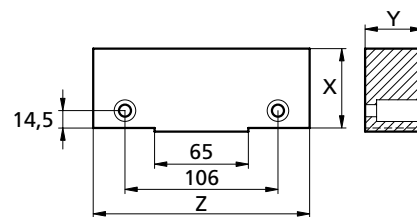
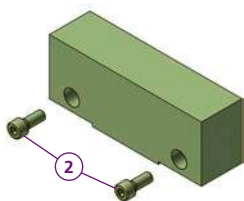

		X	Y	Z	kg
AC1505520W	②	55	20	150	~ 1,28
AC1505540W	M8X20ISO4762	55	40	150	~ 2,55

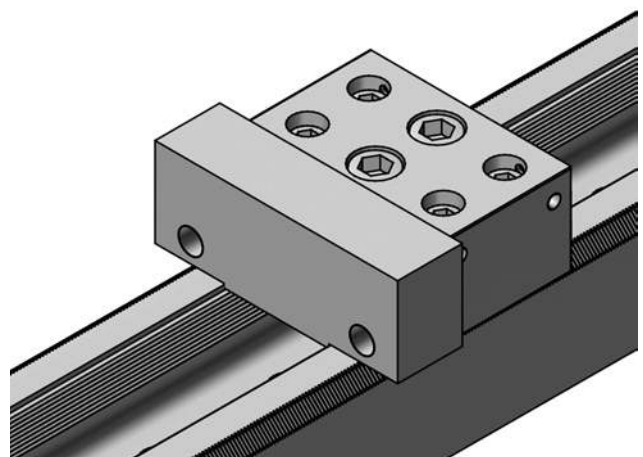

Bestellbeispiel / Ordering example: **AC1505520W**

Kunde <i>Customer</i>			
Maschine <i>Machine</i>		Werkstoff, Halbzeug, Rohteil-Nr., Modell- oder Gesenk-Nr. <i>Raw material, blank or casting-Nr.</i>	
X	Verfahrweg <i>Traverse</i>		mm
Y	Verfahrweg <i>Traverse</i>		mm
Z	Verfahrweg <i>Traverse</i>		mm
Z min.	kleinster Abstand von der Tischoberfläche zur Spindelnase <i>smallest distance from table surface to spindle gauge line</i>		mm
Z max.	grösster Abstand von der Tischoberfläche zur Spindelnase <i>greatest distance from table surface to spindle gauge line</i>		mm
Ø Spindel <i>Spindle</i>	Spindeldurchmesser <i>Spindle diameter</i>		mm
kg max.	Maximale Tischbelastung <i>Maximum loading capacity</i>		kg
A x B	Tischgrösse <i>Size of the table</i>		mm
E	T-Nuten Grösse <i>T-slots size</i>		mm
C	T-Nuten Abstand <i>T-slots distance</i>		mm
Rasterplatte <i>Grid plate</i>	H Raster Abstand <i>Grid distance</i>	mm	G Gewinde & Passungsdurchmesser Ø <i>Thread & Precision Bohre</i>
	Anzahl Werkstücke pro Los <i>Number of workpieces per lot</i>		Stück <i>Pieces</i>

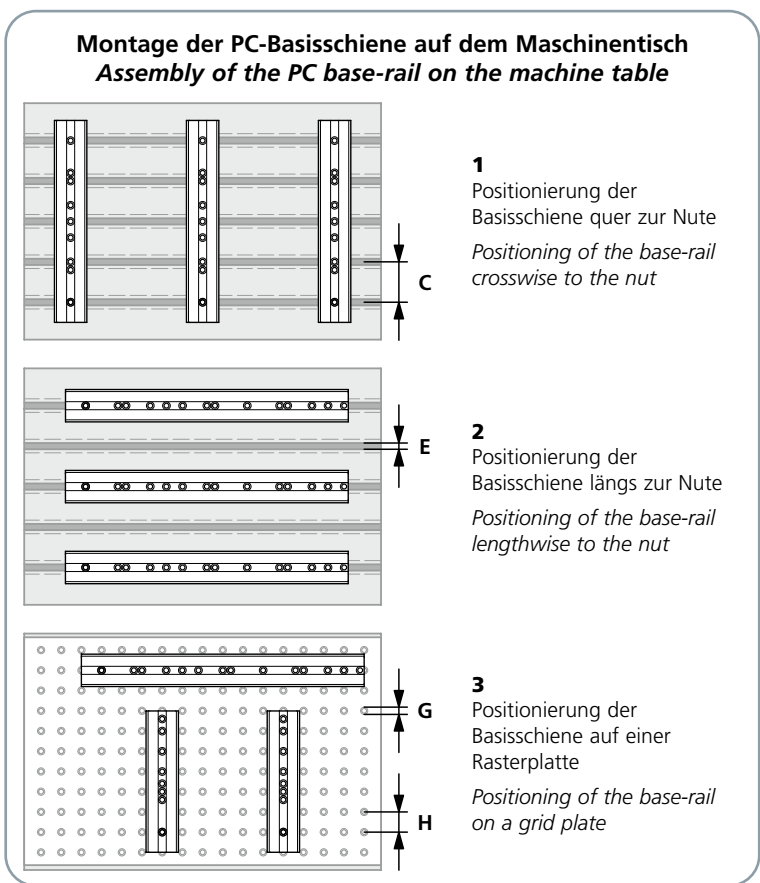
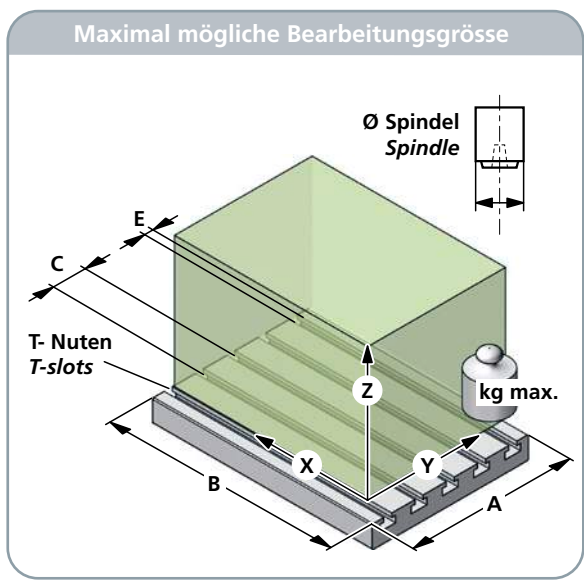



Bitte Werkstückzeichnung beilegen und Bearbeitungsfolge markieren
Enclose drawing of workpiece and mark processing sequence, please

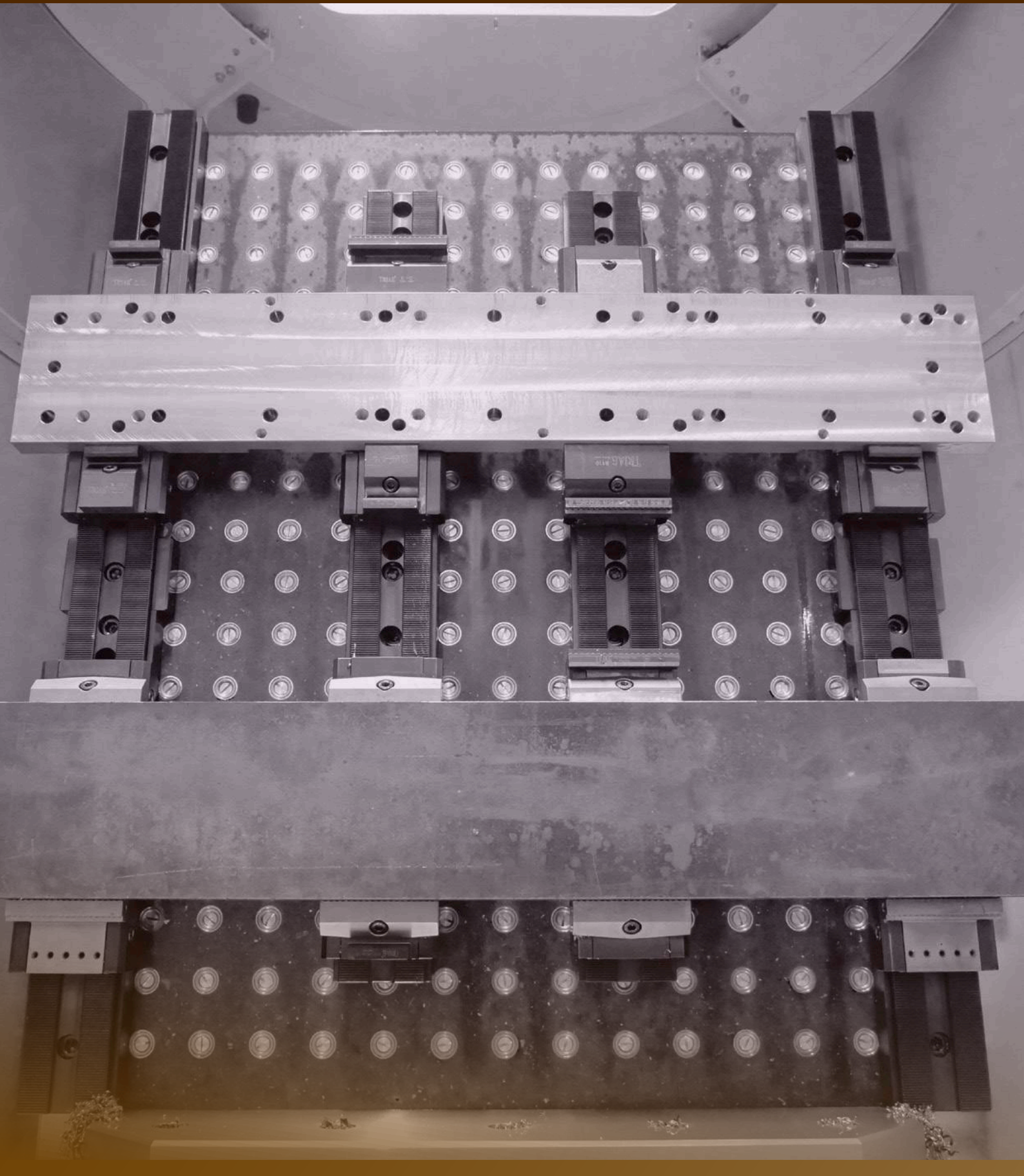

tripoxyMINERAL



 **Einleitung | Introduction** 238 - 243

 **Bedienungsanleitung | Operating manual** 244

Reparaturanleitung für Mineralguss | How to repair epoxy mineral casting 245

Anwendungsbeispiele | Examples of application 247 - 248

Mineralguss | Epoxy mineral 251 - 270

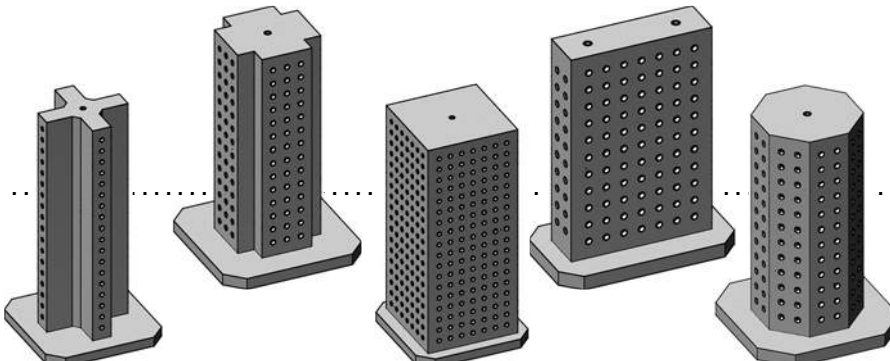

**Mineralgusserhöhung für 5-Achsenmaschinen
 Epoxy casting raises blocks for 5-axis machines** 271

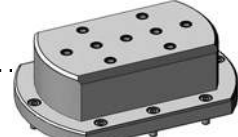

Stahl Mineralguss | Steel epoxy mineral tombstones 272 - 273



Zubehör | Accessories 274 - 275

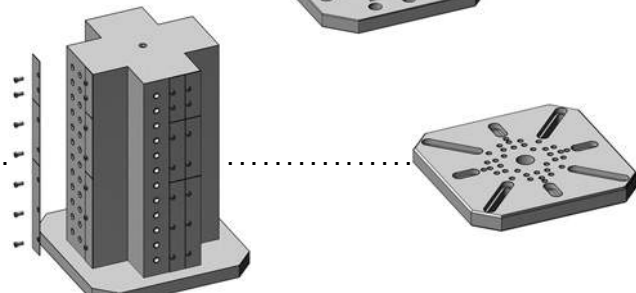

**Stahl Mineralgusserhöhungen mit integriertem Vakuum Anschluss / Steel-epoxy raises block with integrated vacuum
 Balken und Würfel aus Stahl-Mineralguss
 Trunion and cubes made from steel epoxy** 277

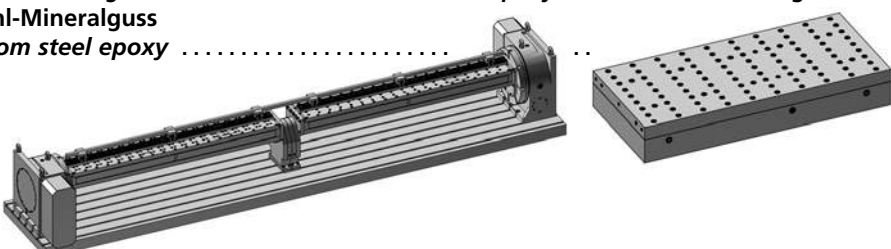

Es ist ein versprechen!
Unsere Mineralgusstürme stehen gerade!

*It's a promise!
Our epoxy tomb stones stand upright!*



Maschinenschonend und leicht, in fast allen Formen herstellbar

Bei den immer schneller werdenden Horizontalbearbeitungszentren ist Gewichtsreduktion der Zuladung ein wichtiger Faktor. Unsere Spanntürme aus Mineralguss haben ein kleineres spezifisches Gewicht als Alu.

Zudem werden Vibrationen derart reduziert, dass auch bei einer Bearbeitung im oberen Turmbereich präzise bearbeitet werden kann. In gewissen Fällen, z.B. bei Werkstückspannungen (ohne Basisschienen) direkt auf den Turm, kann auch ein stahlummantelter Mineralgussturm eine Ergänzung sein.

Reduces machine wear due to low specific weight - can be produced in all sorts of shapes

As the rapid traverse on modern horizontal machining centres is constantly increasing, the weight of the payload becomes obviously an important point. Our tombstones made of epoxy mineral casting are lighter in their specific weight than aluminium.

In addition, vibrations are greatly reduced in a way that even in the upper end of the tombstone high accuracy is guaranteed. In certain cases, as for instance when the fixture is designed without the base rail, that means directly mounted on the cube, the tombstone can be improved by a steel jacket.

- Leicht und stabil
- Vibrationsdämpfung 10 x besser als Grauguss und 100 x besser als Alu!
- Spezifisches Gewicht leichter als Aluminium
- Seitenflächen geschliffen mit Bohrungen (M12 / 12F7)
- Grundplatten nach Maschinenspezifikation
- Andere Formen auf Anfrage

- *Lightweight and rigid*
- *Damping effect 10 x better than cast iron 100 x better than alu!*
- *Specific weight lighter than aluminum*
- *Faces ground, hardened bushings (M12/12F7)*
- *Base plate made to machine specifications*
- *Other dimensions on request*

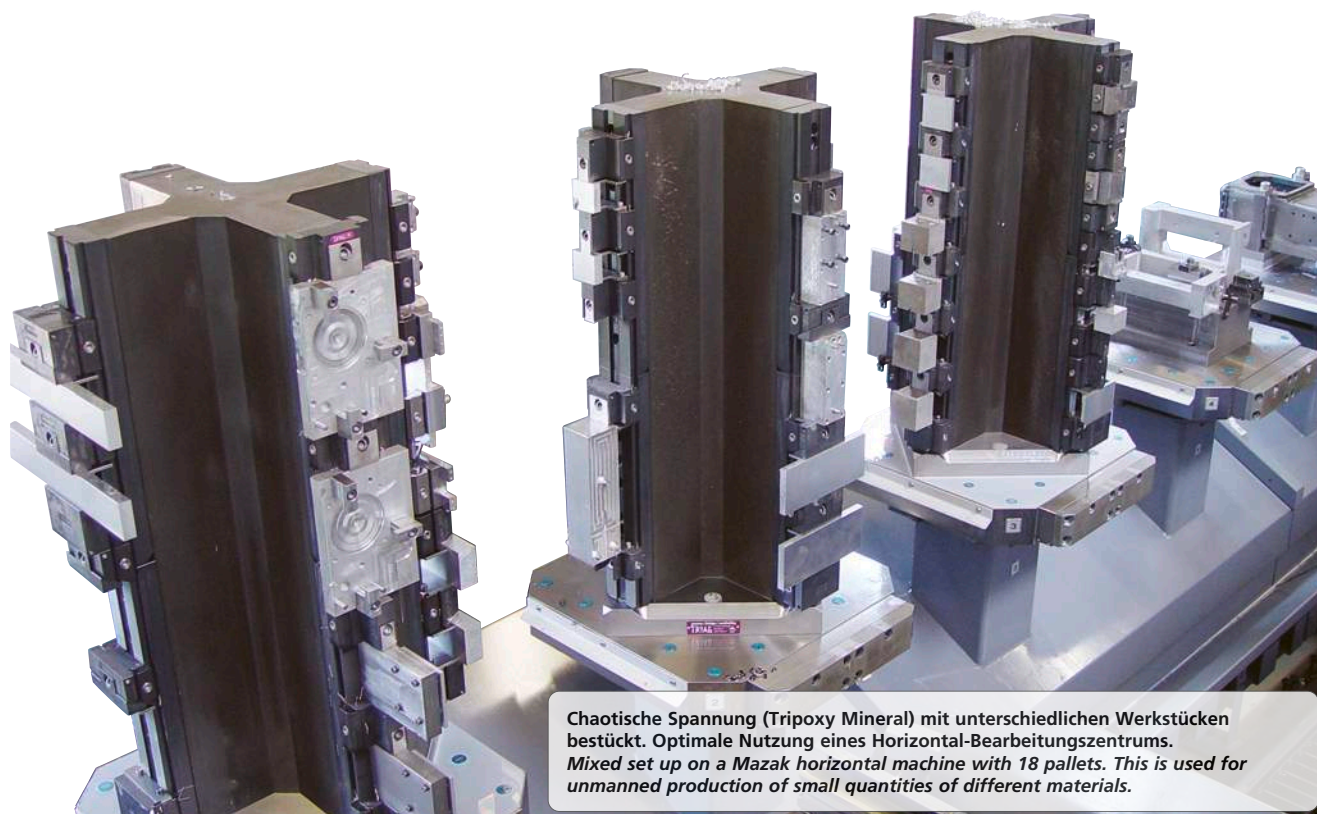

Chaotische Spannung (Tripoxy Mineral) mit unterschiedlichen Werkstücken bestückt. Optimale Nutzung eines Horizontal-Bearbeitungszentrums. Mixed set up on a Mazak horizontal machine with 18 pallets. This is used for unmanned production of small quantities of different materials.

Mineralguss (auch Polymerbeton genannt) ist ein Kunststein, bestehend aus Quarzkies, Quarzsand und Gesteinsmehl. Als Binder dient ein hochwertiger Epoxidharz. Das gemischte Material wird in Giessformen gefüllt.

Während dem Giessprozess wird die Form, mittels Vibrations-tisch ständig vibriert, was zur Verdichtung und Entlüftung der Giessmasse führt. Das spezifische Gewicht ist mit 2,4 kg / dm³ geringer als das von Aluminium und die Vibrationsdämpfung ist 10 mal besser als bei Grauguss, 100 mal besser als Aluminium. Neben den guten Dämpfungseigenschaften ist auch die Temperaturstabilität (geringe Wärmeleitfähigkeit und hohe Wärmekapazität) zu erwähnen.

Das Material ist ausserdem chemisch beständig gegen Öle, Laugen, Säuren und die üblichen Kühlschmierstoffe. Im ausgegossenen Zustand sind die Türme «Umweltneutral».

Mineral casting (also called polymer concrete) is a stone composed of quartz gravel, silica sand and crushed rock. The binder is a high quality epoxy resin. The mixed material is filled into molds.

During the casting process, the form, constantly vibrating. Is resulting in the compaction and extraction of the casting mass. The specific weight is 2,4 kg / dm³ is lower than that of aluminum, and the vibration attenuation is 10 times better than that of cast iron 100 times better than alu. Besides the good damping properties, the temperature stability is to be mentioned (low thermal conductivity and high heat capacity).

The material is also chemically resistant to oils, alkalis, acids and the usual cooling lubricants.

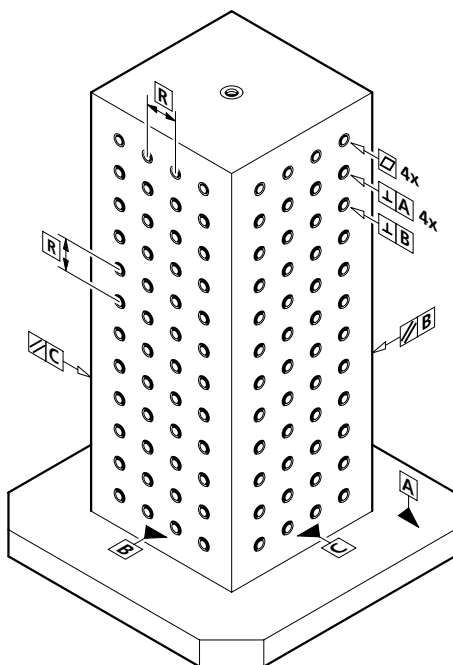

Eigenschaften Caractéristiques	Mineralguss Epoxy mineral	GG20	hochfestes Alu high density Alu
Dichte / Density [kg/dm ³]	ca. 2,4	ca. 7,1-7,3	ca. 2,76
Logarithmisches Dekrement grösser als (Vibrationsdämpfung) Logarithmic Decrement (damping)	0,035	0,004	0,0004
Längenausdehnungs-koeffizient Coefficient of linear expansion [1/K]	ca. 12x10 ⁻⁶	ca. 10x10 ⁻⁶	ca. 23x10 ⁻⁶
Zugfestigkeit / Tensile strength [N/mm ²]	15 - 20	200 - 400	470 - 520
Wärmeleitfähigkeit Thermal conductivity [W/mK]	ca. 2	ca. 50	ca. 140

Lagetoleranz der Rasterbohrungen Positioning tolerance of the holes	R	0 - 500 mm ± 0,01 501 - 1000 mm ± 0,02
Ebenheit Flatness		0,01 mm / 300 mm
Parallelität Parallelism		0,01 mm / 300 mm
Winkligkeit Deviation of angle		0,01 mm / 200 mm

Mineralguss wird unter anderem für folgende Anwendungen eingesetzt: Cast mineral is among other things the following Applications used:

- ➔ Maschinenbetten
Machine beds
- ➔ Maschinenständer und -portale
Machine column and portals
- ➔ Als Alternative zu Grauguss (Kosten, Umweltfreundlichkeit)
As an alternative to cast iron (cost, environmental friendliness)
- ➔ Als Alternative zu Schweisskonstruktionen
As an alternative to welded constructions
- ➔ Als Alternative zu Natursteinanwendungen (z.B. Messtische, Reinraumtechnologie)
As an alternative to natural stone applications (eg, measuring tables, clean room technology)
- ➔ Generell steifigkeits- und festigkeitsdimensionierte Strukturbauteile
General stiffness and strength-scale structural components
- ➔ Integrierte Funktionalität möglich (Schläuche, Ventile, Elektrik, Lastanker etc.), auch nachträgliches Eingiessen möglich
Integrated functionality possible (hoses, valves, electrical, anchor load, etc.), and subsequent pouring possible
- ➔ Füllung von Mineralguss in Blechmantelkonstruktionen (z.B. unsere Stahl-Mineralguss-Basissschienen)
Filling of mineral cast in metal shell constructions (eg, our steel rails with epoxy mineral cast base)

tripoxyMINERAL

Die Gewichtsreduktion der Zuladung ist bei den immer schneller werdenden Horizontalbearbeitungszentren ein wichtiger Faktor. Die Spanntürme aus Mineralguss haben ein kleineres spezifisches Gewicht als Aluminium. Diese verfügen über eine so hohe Vibrationsdämpfung, dass dadurch im oberen Bereich der Türme sehr präzise gearbeitet werden kann und dabei exzellente Oberflächengüten erreicht werden.

Seit Jahren bietet die Triag International AG aus eigener Produktion mit den Tripoxy Mineral-Spanntürmen eine sehr gute Alternative zu Spanntürmen aus anderen Materialien (z.B. Grauguss- oder Aluminium) an.

The weight reduction of the load is an important factor in the increasingly rapid horizontal machining centers. The tombstones of mineral casting have a lower specific weight than aluminum. Another big advantage is the vibration clamping which helps to achieve excellent surfaces on your workpieces, even on top of your tombstone. Beside that there are another two good reasons for epoxy mineral tombstones. One is the materials is not getting rusty and the slow thermal expansion.

For years, the Triag International AG offers its own production with the Tripoxy mineral tombstones, a very good alternative to tombstones made of other materials (such as cast iron or aluminum) to.

**Mineralgusstürme samt
 Spansystem aus einer Hand!**

**Epoxy mineral tombstones including
 clamping system from one source!**



Mineralgussturm kombiniert bestückt mit Power Clamp und Magneten.
 Epoxy cube equipped with magnet and Power Clamp



Grosse Platte auf einem rechteckigen
 Mineralgussturm.
 Large plates on epoxy tombstone.



Chaotische Fertigung auf einem
 Mineralgussturm in Kreuzform.
 Mixed set up on cross epoxy tombstone.

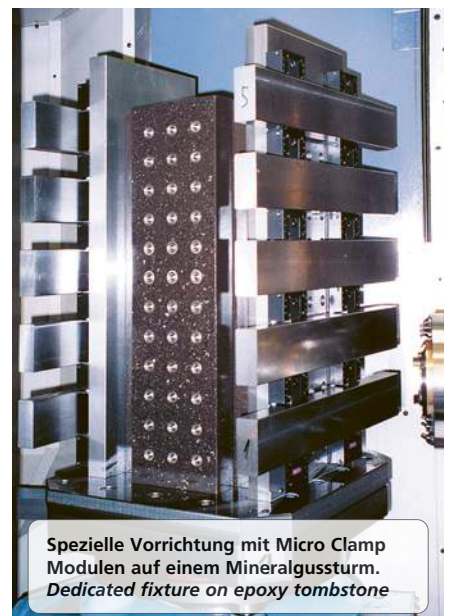

Spezielle Vorrichtung mit Micro Clamp
 Modulen auf einem Mineralgussturm.
 Dedicated fixture on epoxy tombstone

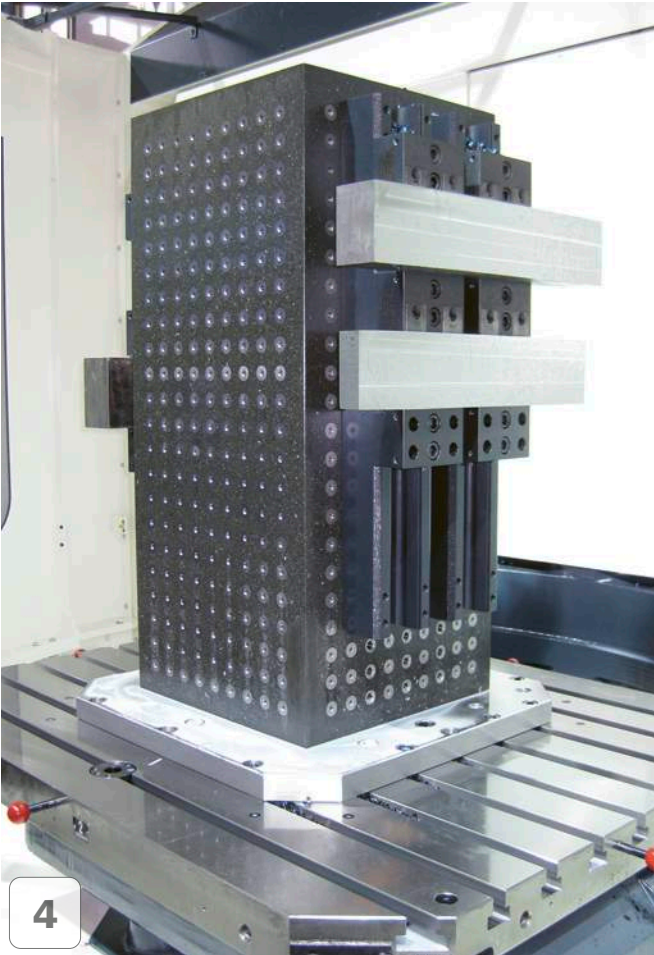
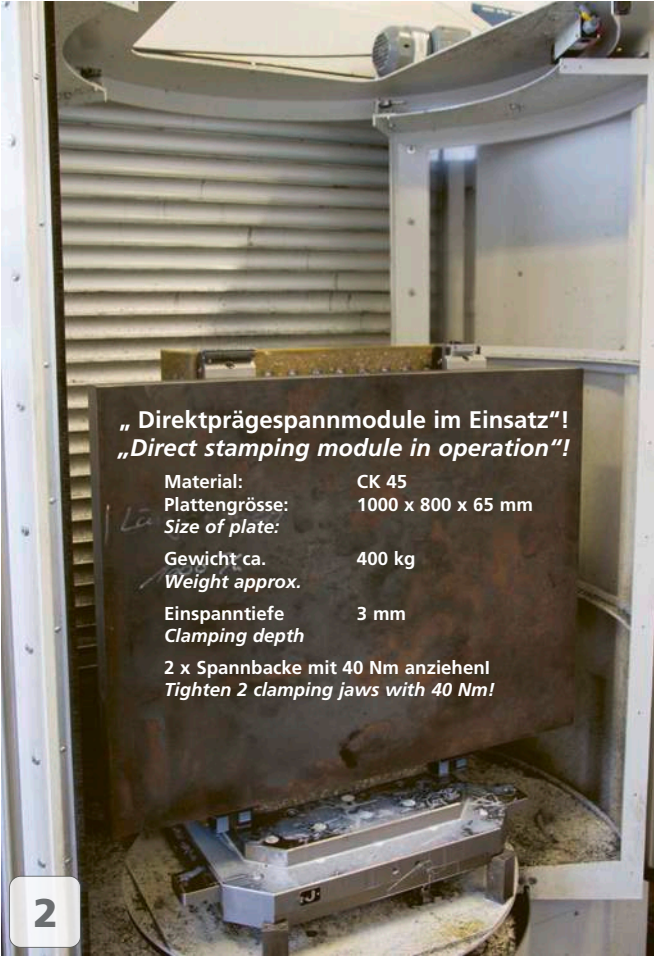

Linear stamping

Stahl-Mineralguss

Steel-epoxy mineral tombstones

tripoxyMINERAL

Stahl-Mineralguss seit 2004 - das ideale Material für Spanntürme

Die Firma Triag International AG hat seit 2004 diese stahlummantelten Türme mit sehr guten Ergebnissen bei Kunden im Einsatz. In den meisten Fällen können optimale Lösungen durch Standardangebote kostengünstig und modular eingerichtet werden.

Steel-epoxy combinations since 2004 - the ideal material for tombstones and ricer cubes

Triag International AG customers are employing successfully tombstones with steel jackets since 2004. In most cases optimal solutions can be found with standard Triag clamping devices.

Stahl-Mineralguss für die perfekte Vibrationsdämpfung
Steel epoxy tombstone for perfect vibration dampening

Max. Palettenzuladung auf Mazak H BZ
Max pallet load on this Mazak application = 600kg H = 800

Komplettes Gewicht 600 kg inkl. Werkstücke WS = 8 x 38 kg
Complete load weighs 600 kg incl-parts

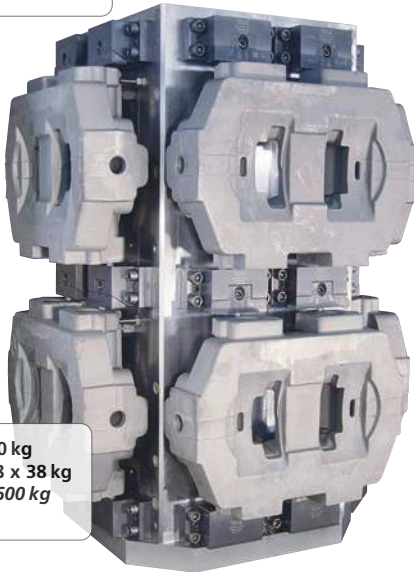

200 x 400 x 1330

Flügelteil für Airbus A320
Tail wing part for Airbus A320

Stahlmineralguss-Säulen mit Power Clamp für die Fertigung von Flügelteilen.
Steel epoxy frames machining wing parts on a Makino machine

Stahl-Mineralguss Dreieck-Turm
Steel epoxy triangle cube



Stahl-Mineralguss Pyramide
Steel epoxy pyramid stomp

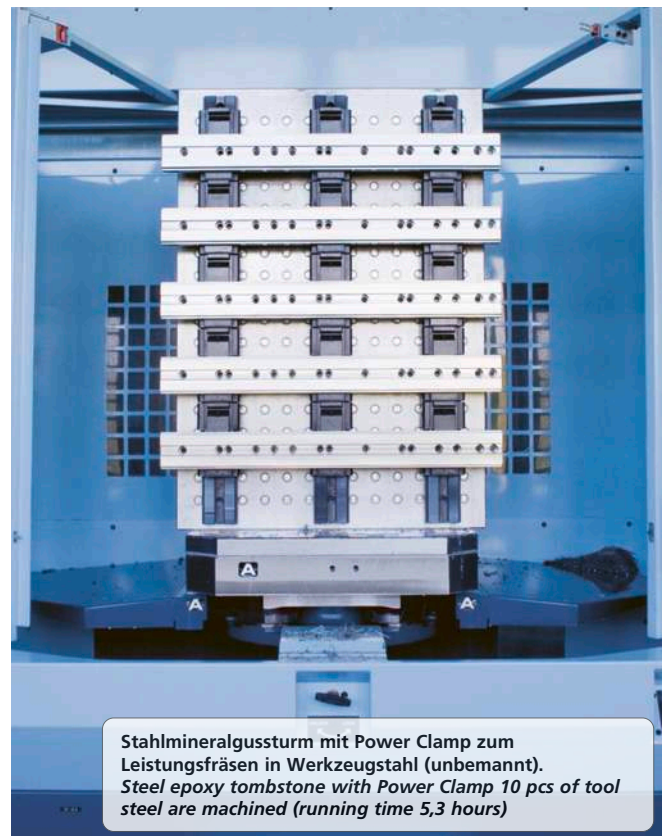

Stahlmineralgussturm mit Power Clamp zum Leistungsfräsen in Werkzeugstahl (unbemannt).
Steel epoxy tombstone with Power Clamp 10 pcs of tool steel are machined (running time 5,3 hours)

Es gibt eine Vielzahl von Standardformen

There are a variety of standard forms

tripoxyMINERAL

Die Mineralgusstürme können in fast allen

The epoxy mineral tombstones can be manu-
factured in almost any shape.

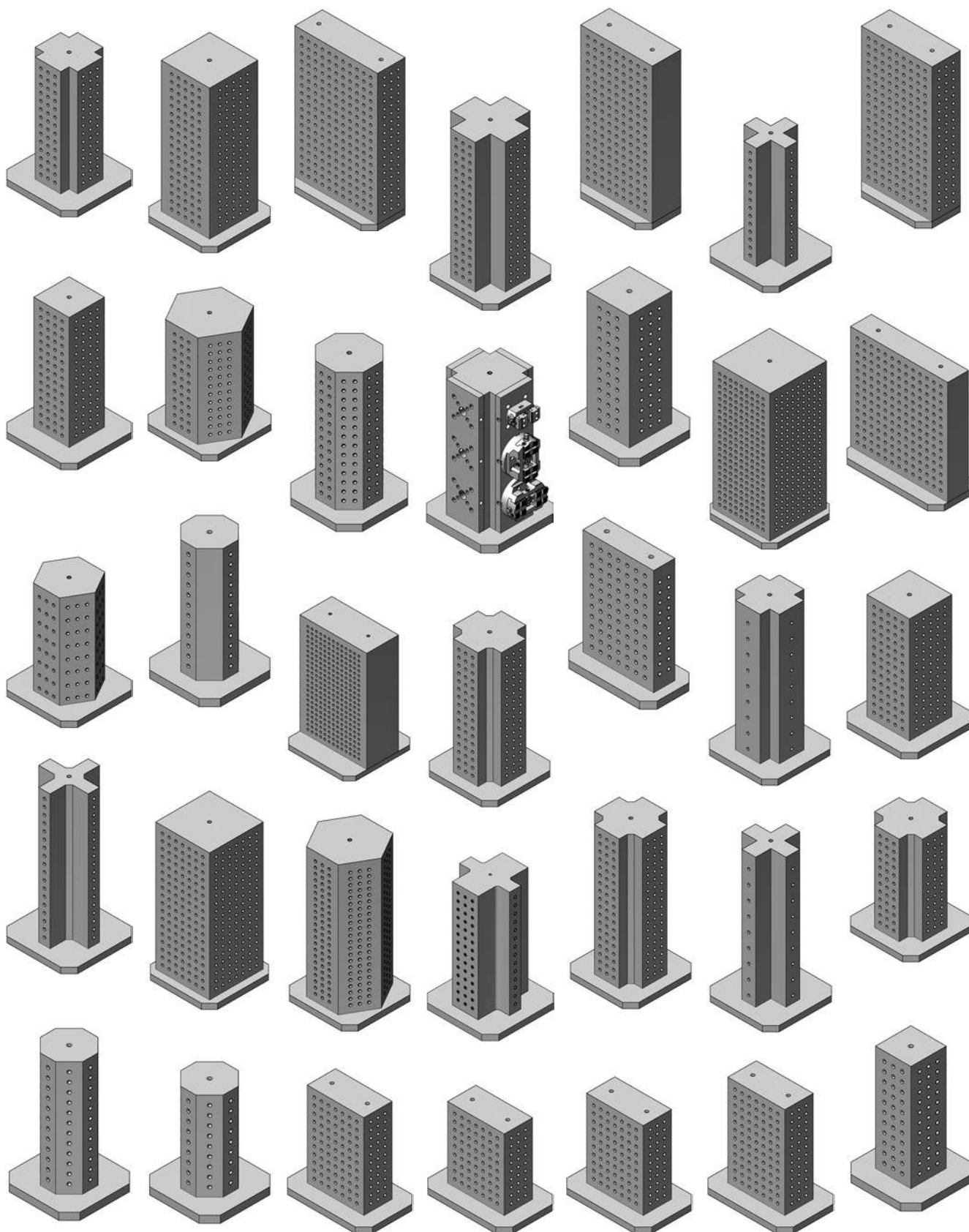

Andere Grössen, Formen und Raster, welche nicht im Katalog sind, können nach Kundenwunsch produziert werden.
Other sizes, forms and grid which are not in the catalogue can be produced on customer's request.

ACHTUNG / CAUTION

Bevor Mineralgusstürme eingesetzt werden, beachten Sie bitte die folgenden Punkte! *Prior to inserting the tombstones please note the following points!*

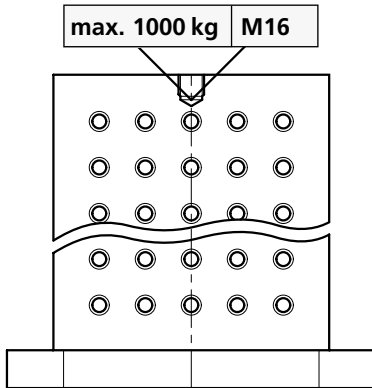

Höchstlast des angehängten Stücks / Maximum load of the affixed piece		
Drahtseil Steel rope	Bei fest angezogener Schraube For tightened screw	Bei zwei Schrauben insgesamt For two tightened screws
MRD 12 = 500 kg MRD 16 = 1000 kg	M12 = 340 kg M16 = 700 kg (DIN 580)	M12 = 240 kg M16 = 500 kg (DIN 580)

Bitte beachten Sie, dass die meisten Ringschrauben eine maximale Last haben von: **M12: 340 kg / M16: 700 kg** auch muss die Ringschraube bis zum Anschlag eingedreht sein!

*Please note that most of the lifting screws have a maximum load of: **M12: 340 kg / M16: 700 kg** It is also important that the lifting screw is driven into the socket!*

Oberflächenabnutzung

Durch schnelle, auf die Turmoberfläche schlagende Späne, sowie durch Hochdruckkühlung, die direkt auf den Turm spritzt, kann die Oberfläche des Mineralgussturmes beschädigt werden!

Surface wear

The surface of the tombstone can be seriously damaged by chips hitting the tombstone quickly as well as by high pressure cooling water splashing directly onto the tombstone!

Massnahmen:

Dort wo lange Späne oder auch kurze abrasive Späne auf den Turm schlagen, Abdeckbleche benutzen! (Abdeckbleche siehe Seite 244)

Measure:

Use cover sheets wherever long or short abrasive chips hit the tombstone! (Cover sheets page 244)

Achtung Grenzfälle

Folgende Anwendungen können nur bedingt eingesetzt werden, da eine einzelne Schraube auf Zug ohne Gegenlast die eingegossene Buchse belastet!

Attention, limited application

The following applications only have limited use as a single screw without a counterweight puts tremendous tension on the integral socket!



Max. Anzugsmomente beachten.

Note max. starting torques.

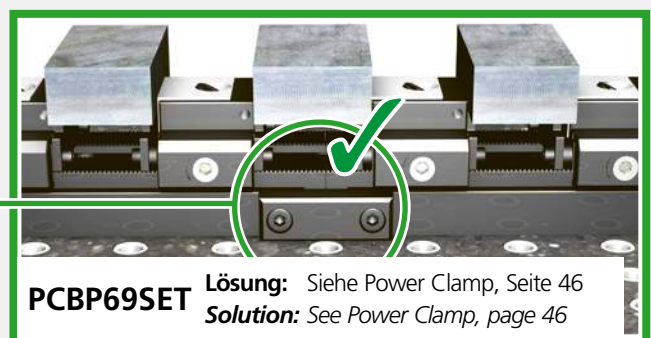
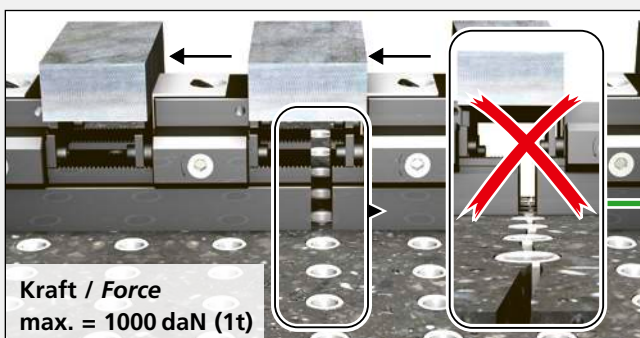
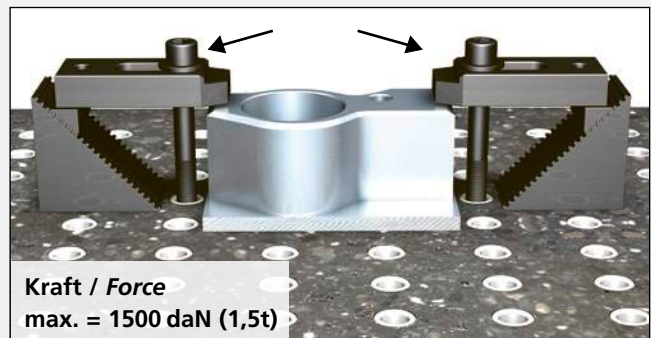
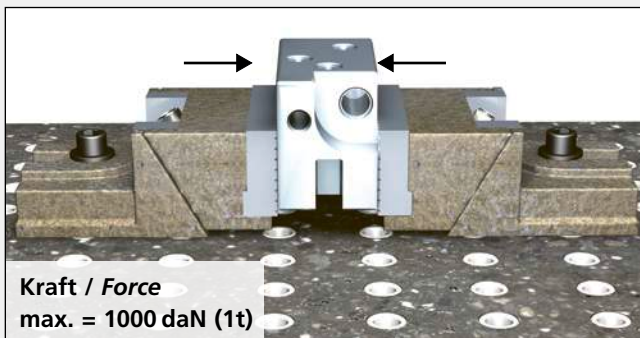

Bruchstelle

Bruchstelle des Mineralgussturmes mit Aceton reinigen, danach mit Metallplatte und Schraubzwinde einschalen. Bei grossen Reparaturen sollte die Platte zusätzlich mit Hartwachs (Bild 6) eingerieben, poliert und nachträglich mit Silikon abgedichtet werden. (Siehe Bilder 1-4)

Mineralgussreparaturset (Bild 5)

MREP-SET 0300 ~ 300 gr = ~ 2 dl

Das Reparaturset setzt sich aus dem Harz, Härter und Füller zusammen. Das Mischverhältnis ist: auf 27 gr Härter kommt 100 gr Harz und 150 gr Füller.

Das Verhältnis ist genau abgewogen. Wichtig ganze angelieferte Menge gebrauchen.

Harz und Härter zusammengiessen und intensiv 2 Min. rühren. Das Durchmischen der Masse ist entscheidend für das optimale Abbinden des Mineralgusses. **Danach Füller dazugeben und das gleiche nochmals 2 Min.** lang untereinander mischen bis eine gipsähnliche Masse entsteht.

Die flüssige Masse wird nun in die Bruchstelle eingegossen.

Das Aushärten der Reparaturmasse beträgt 24 Std. Die Unebenheit der frisch eingegossenen Fläche, wird mit einem Schleifstein plangeschliffen.

Point of rupture

Clean the section of fracture with Acetone, then press metal plates with screw clamps onto the point of damage. If the damage is a major one the metal plates must be waxed first (picture No. 6) and sealed with Silicon if necessary (pls. note pictures 1 to 4)

Repair kit for epoxy mineral castings (picture 5)

MREP-SET 0300 ~ 300 gr = ~ 2 dl

The repair kit consists of the resin, the hardener, and the filler. The mixture ratio is: 27 gr of hardener, 100 gr of resin and 150 gr of filler.

These components are exactly portioned in the kit and should be used up entirely.

The resin and the hardener should be poured together and mixed for 2 min. This mixing process is essential for a good bonding with the mineral casting. **Then the filler should be added while mixing the mass another 2 min.** It will reach a consistency like plaster.

This mortar must be poured into the point of rupture.

The hardening process takes 24 hours. Protruding material can be levelled with a grindstone.

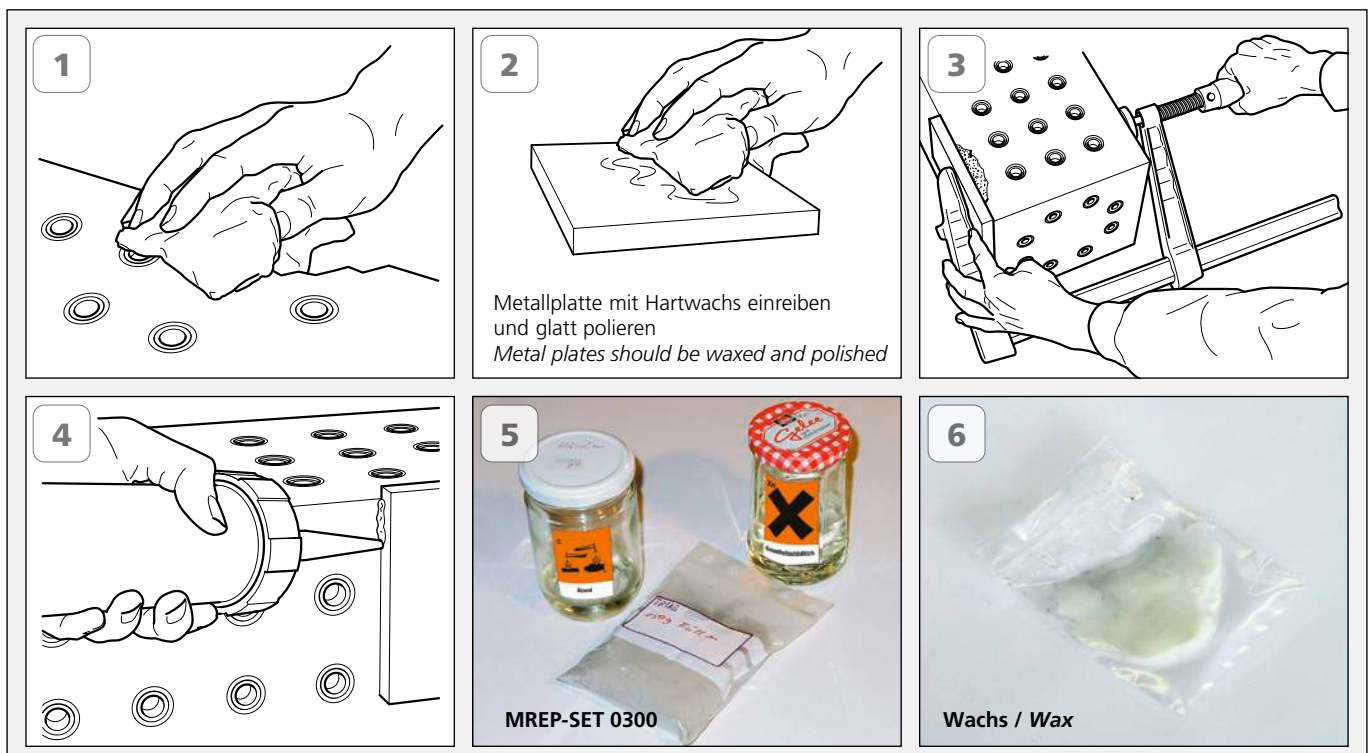

Kunde <i>Customer</i>			
Maschine <i>Machine</i>		Werkstoff, Halbzeug, Rohteil-Nr., Modell- oder Gesenk-Nr. <i>Raw material, blank or casting-Nr.</i>	
X max.	X Achse Hub <i>X axis stroke</i>		mm
Y min.	Kleinsten Abstand von der Palettenoberseite zur Spindelachse <i>Smallest distance from pallet surface to spindle center</i>		mm
Y max.	Grösster Abstand von der Palettenoberseite zur Spindelachse <i>Greatest distance from pallet surface to spindle center</i>		mm
Z min.	Kleinsten Abstand von der Palettenachse zur Spindelchse <i>Smallest distance from pallet center to spindle gauge line</i>		mm
Z max.	Grösster Abstand von der Palettenachse zur Spindelchse <i>Greatest distance from pallet center to spindle gauge line</i>		mm
∅ Spindel <i>Spindle</i>	Spindeldurchmesser <i>Spindle diameter</i>		mm
kg max.	Maximale Tischbelastung <i>Maximum loading capacity</i>		kg
∅D max.	Maximaler Störkreis des Werkstücks <i>Maximum workpiece diameter</i>		mm
H max.	Maximale Beladehöhe des Werkstücks <i>Maximum workpiece height</i>		mm
A x B	Palettenabmessung <i>Size of pallet</i>		mm
	Anzahl Werkstücke pro Los <i>Number of workpieces per lot</i>		Stück <i>Piece</i>

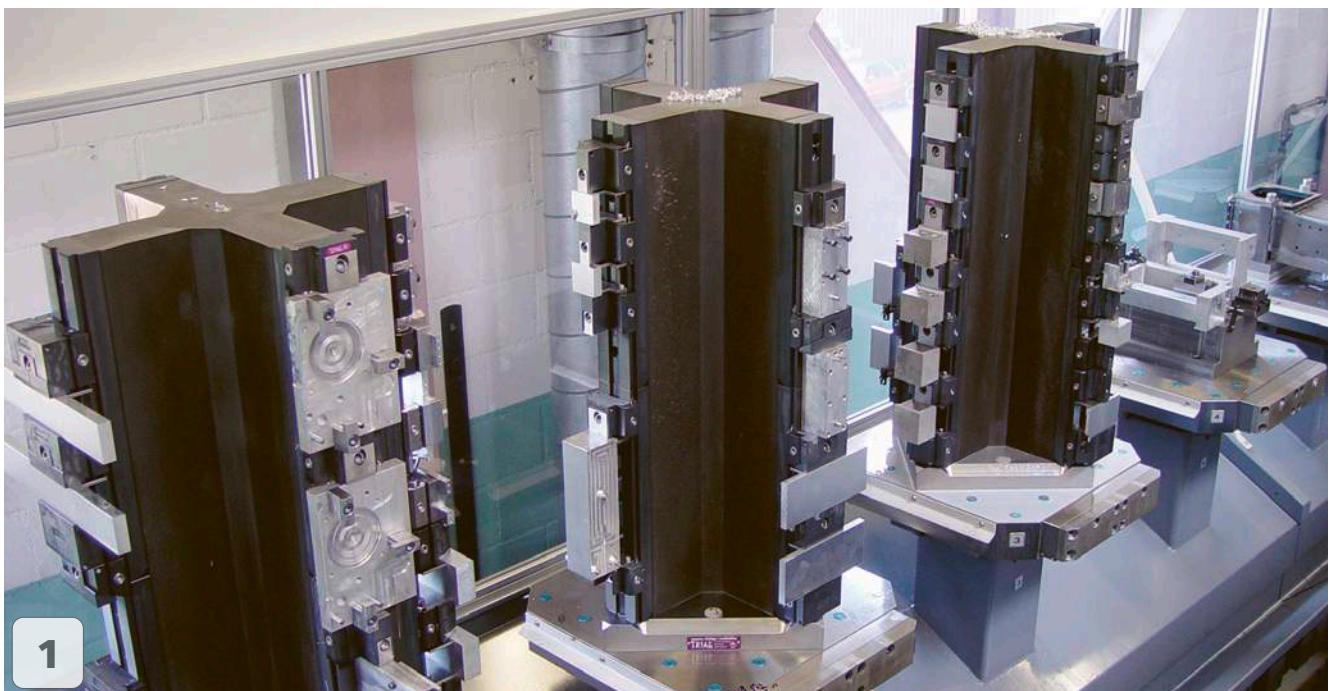
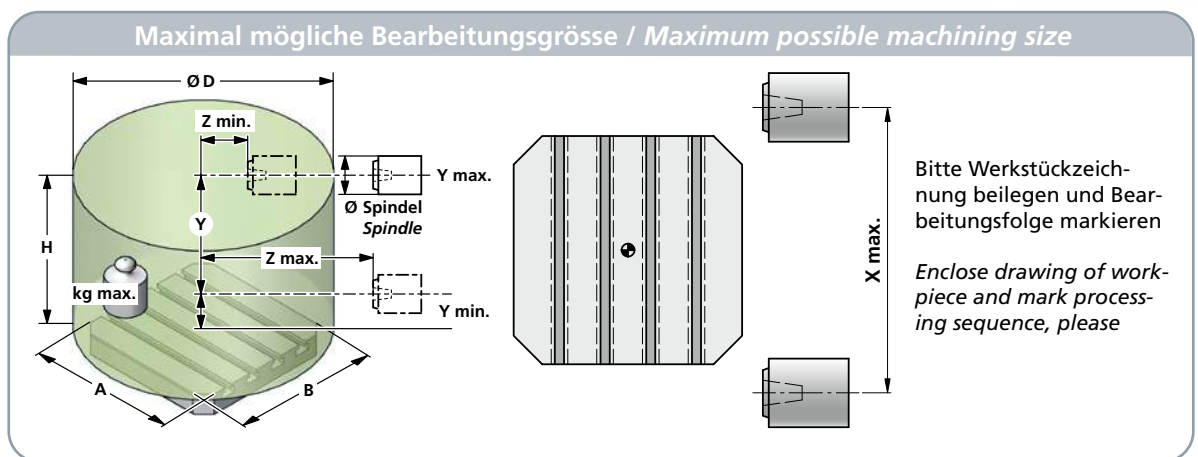

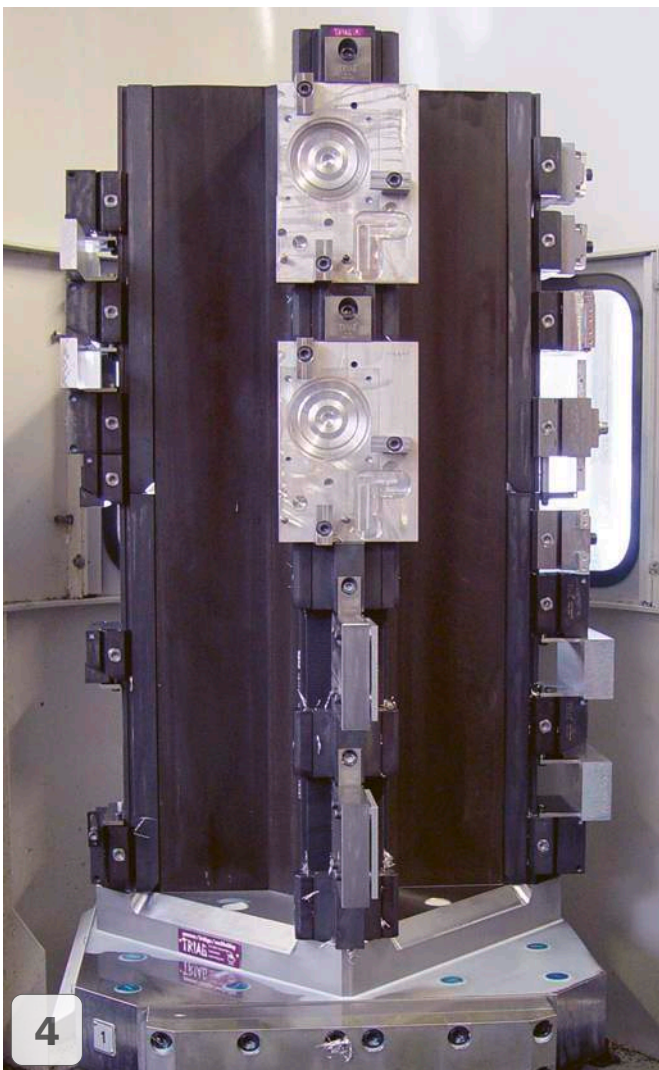
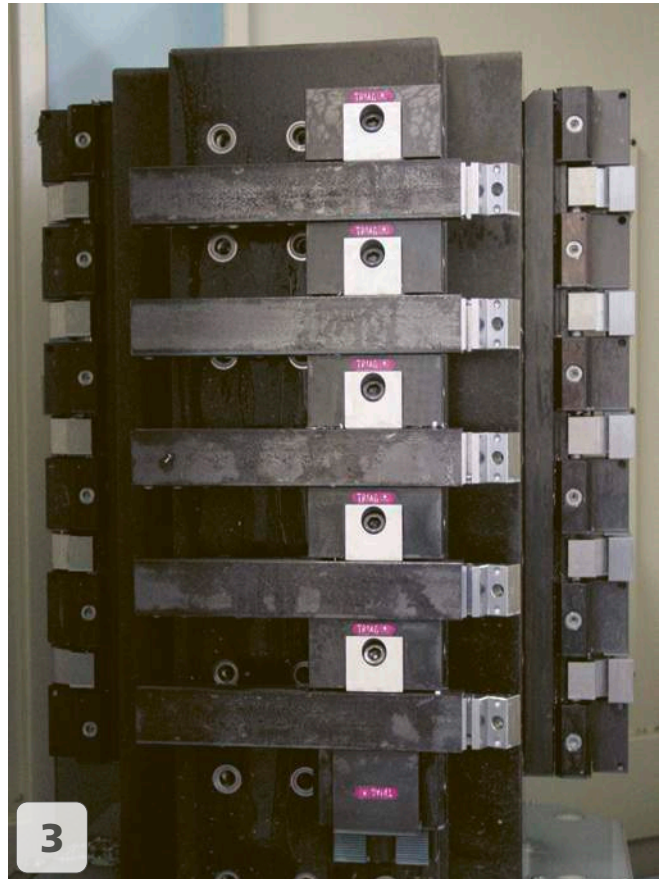
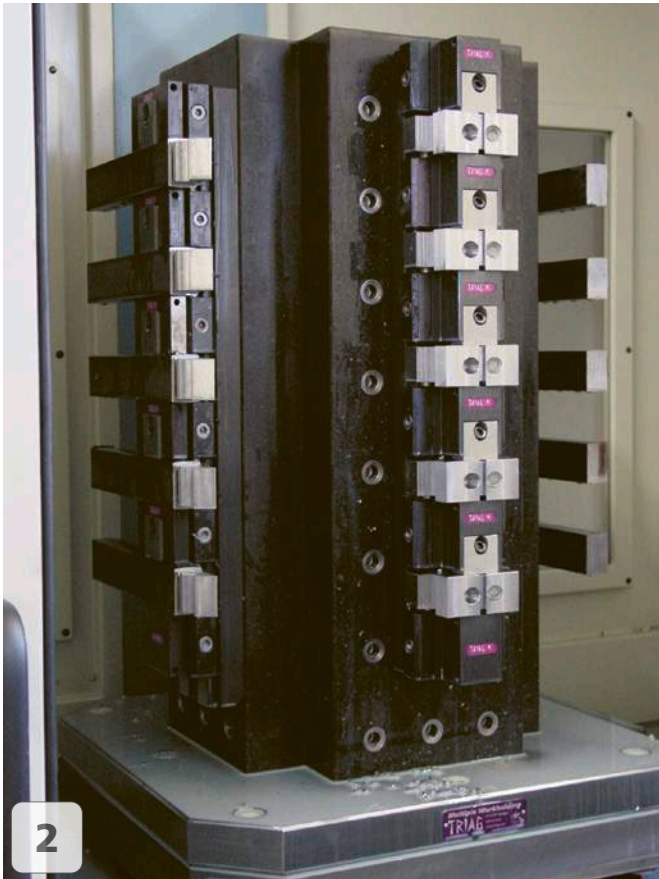

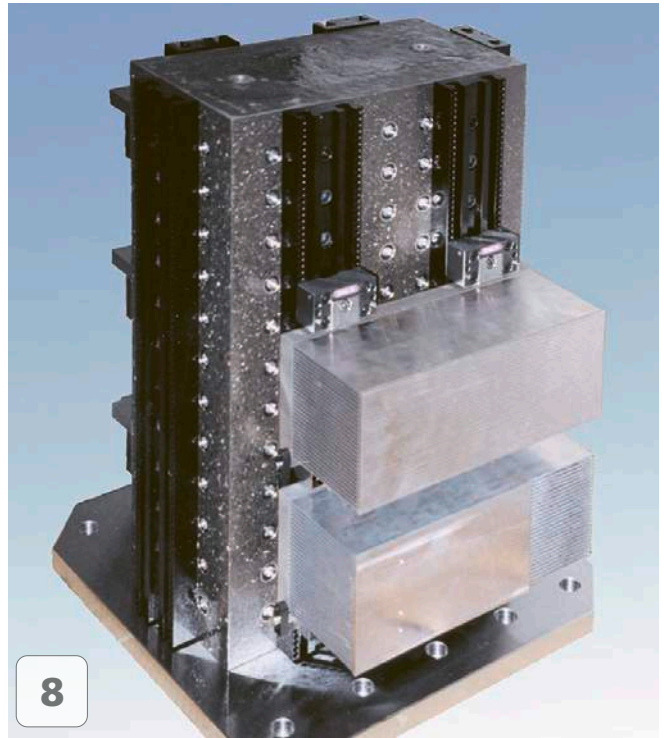

Stahl-Mineralguss Lösungen / Steel epoxy mineral tombstones solutions

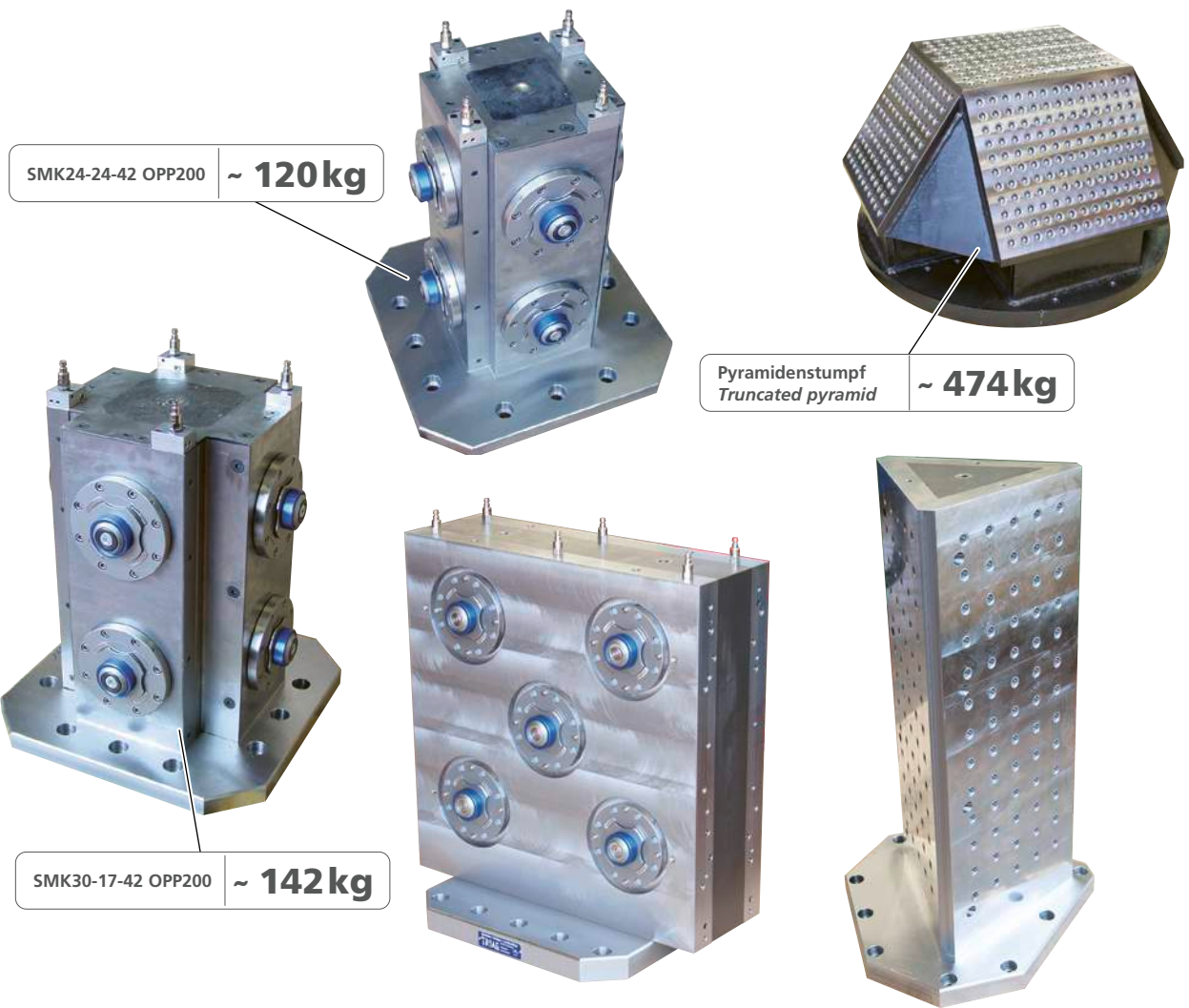

SMK24-24-42 OPP200 ~ 120kg

Pyramidenstumpf
 Truncated pyramid ~ 474kg

SMK30-17-42 OPP200 ~ 142kg

Turm-Material <i>Tombstone material</i>	
M	Mineralguss mit Stahldübel <i>Epoxy mineral with steel anchor</i>
SM	Stahl Mineralguss <i>Steel epoxy mineral tombstones</i>
G	Grauguss <i>Cast iron</i>

Grösste Schlüsselweite <i>Major width</i>	
12	120 mm
20	200 mm
24	240 mm
25	250 mm
30	300 mm
32	320 mm
35	350 mm
40	400 mm
42	420 mm
50	500 mm
60	600 mm
63	630 mm
70	700 mm

Höhe <i>Height</i>	
50	500 mm
55	550 mm
56	567 mm
60	600 mm
62	620 mm
65	650 mm
66	660 mm
70	700 mm
75	750 mm
80	800 mm
85	850 mm
90	900 mm
95	950 mm

M

K

35

18

95

R50

Modultyp <i>Type of module</i>	
K	Kreuz <i>Cross</i>
Q	Quadrat <i>Square</i>
R	Rechteck <i>Rectangular</i>
S	Sechseck <i>Hexagonal</i>
A	Achteck <i>Octagonal</i>
X	Spezialform <i>Special shape</i>

Aufspannbreite <i>Usable width</i>	
08	80 mm
09	90 mm
86	86 mm
10	100 mm
12	120 mm
15	150 mm
16	160 mm
18	180 mm
1808	180 / 80 mm
19	184 mm
20	200 mm
23	231 mm
24	240 mm
25	250 mm
30	300 mm
35	350 mm
40	400 mm
42	420 mm

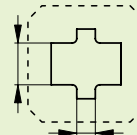

Raster <i>Grid</i>	
R40	40 mm
R50	50 mm
R80	80 mm
R100	100 mm
OPP	200 mm

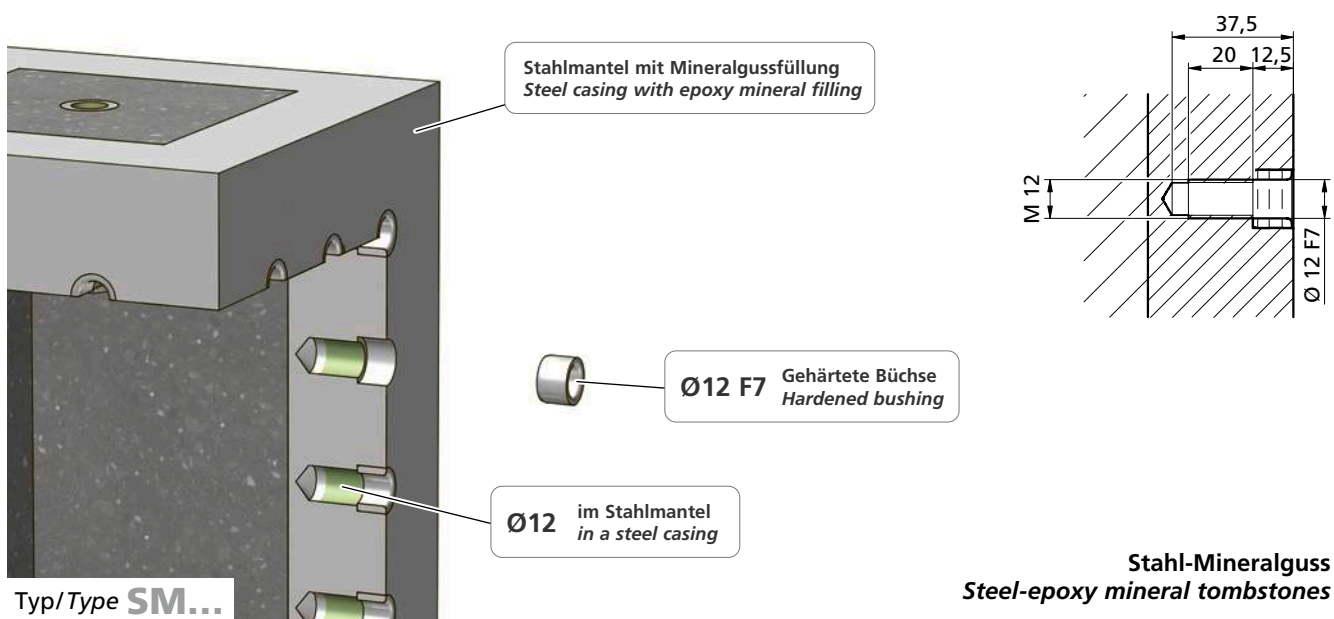
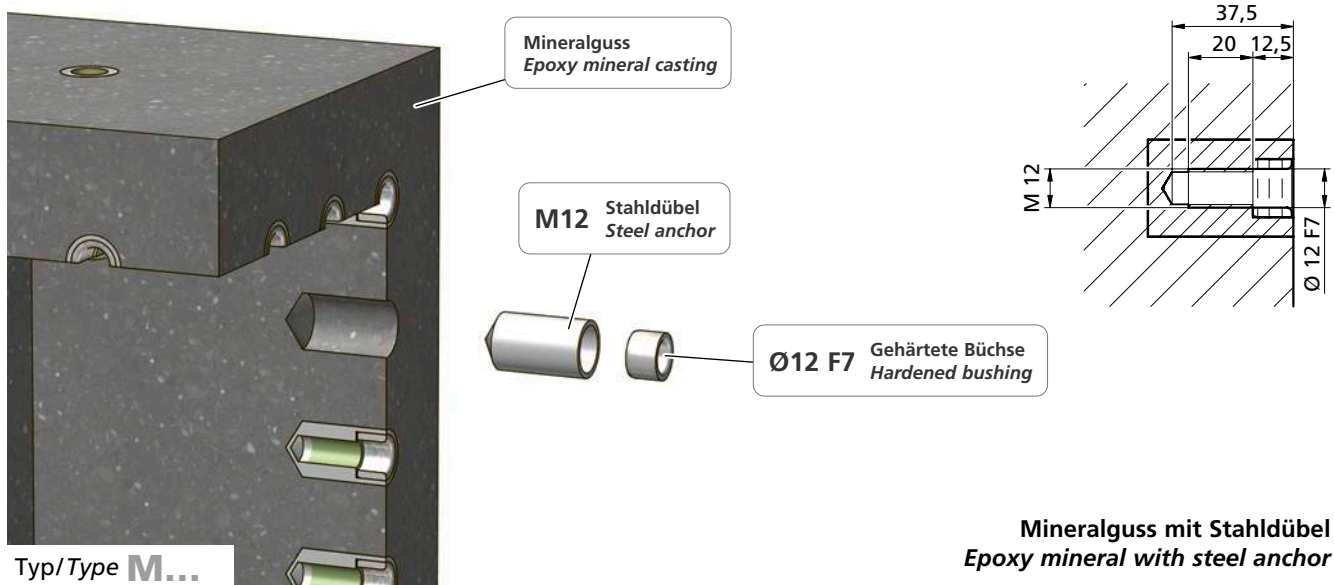

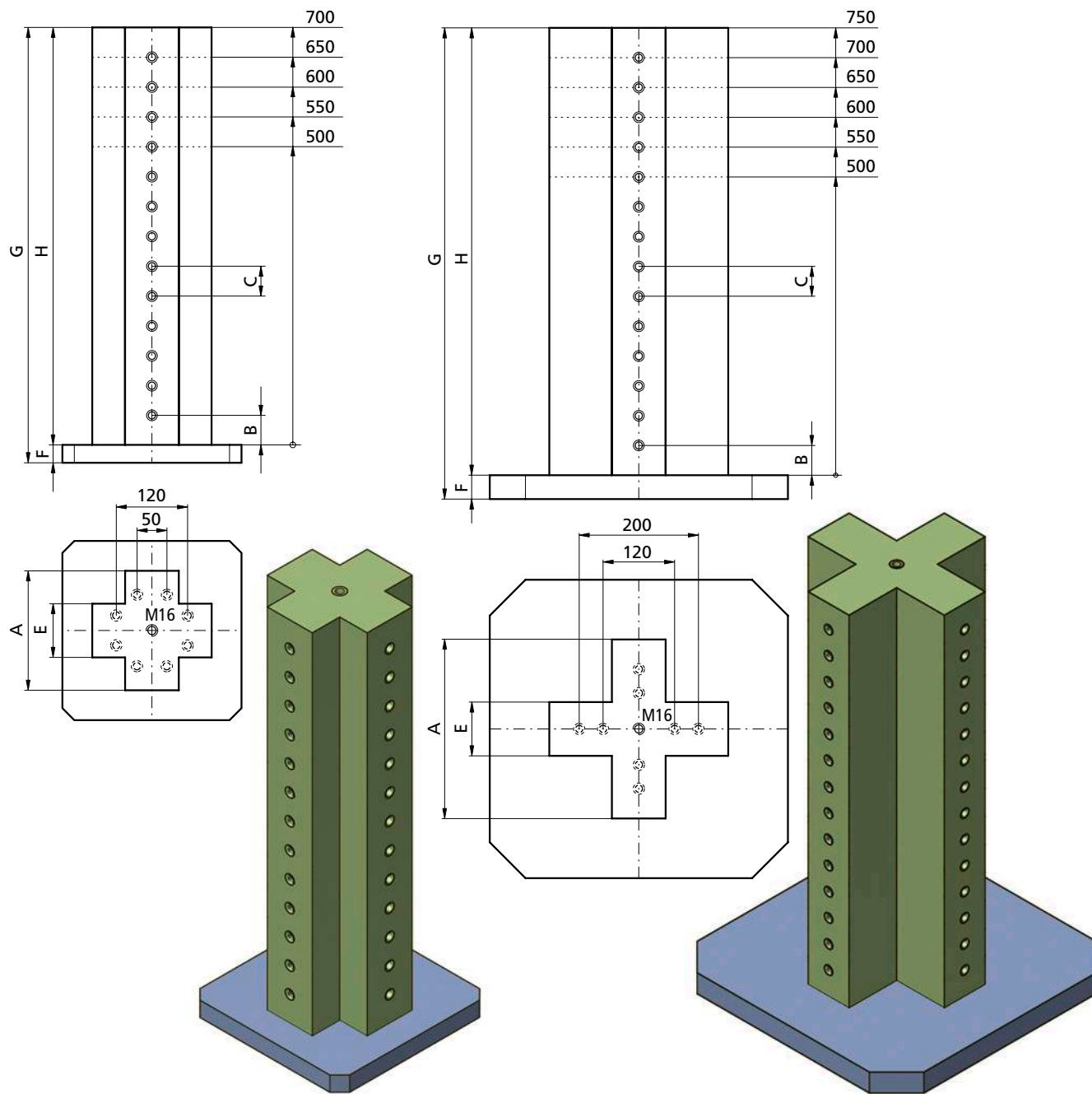

Mineralgussturm mit
Stahldübel
Epoxy Mineral with
Steel Anchor

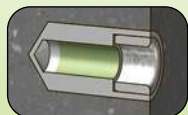

Seite / Page 250

Bestellbeispiel
Ordering example: **MK200965R50** &

p. 274

Grundplatte wird passend
zu Ihrer Maschinenpalette
hergestellt und muss separat
bestellt werden!
Base plate according to your
machine configuration please
order extra!

	kg*	A	B	C	E	F	G	H	Raster / Grid
MK200950R50	~38	200	50	50	90	(30)	(530)	500	36 x M12/12F7
MK200955R50	~42	200	50	50	90	(30)	(580)	550	40 x M12/12F7
MK200960R50	~45	200	50	50	90	(30)	(630)	600	44 x M12/12F7
MK200965R50	~49	200	50	50	90	(30)	(680)	650	48 x M12/12F7
MK200970R50	~53	200	50	50	90	(30)	(680)	700	48 x M12/12F7
MK300950R50	~60	300	50	50	90	(40)	(540)	500	36 x M12/12F7
MK300955R50	~66	300	50	50	90	(40)	(590)	550	40 x M12/12F7
MK300960R50	~72	300	50	50	90	(40)	(640)	600	44 x M12/12F7
MK300965R50	~78	300	50	50	90	(40)	(690)	650	48 x M12/12F7
MK300970R50	~84	300	50	50	90	(40)	(740)	700	52 x M12/12F7
MK300975R50	~90	300	50	50	90	(40)	(790)	750	56 x M12/12F7

* Gewicht ohne Grundplatte! / Weight without baseplate!

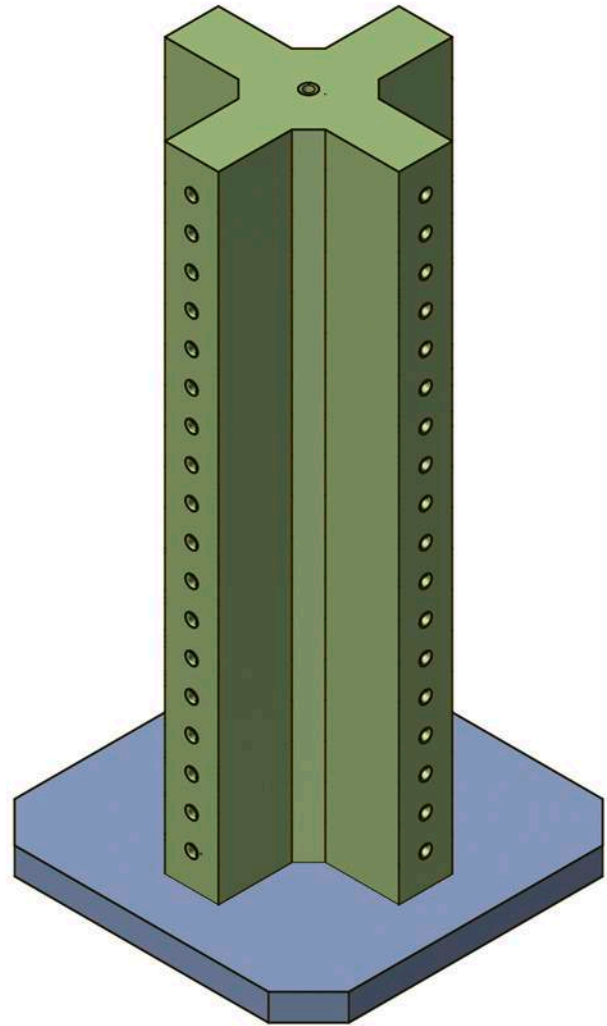
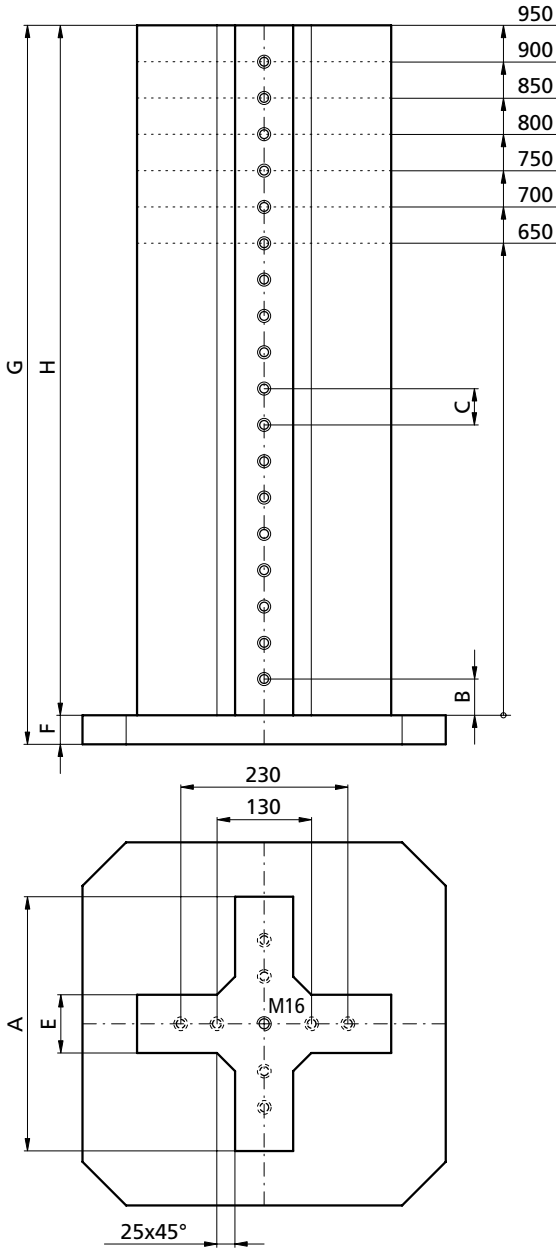

Grundplatte wird passend zu Ihrer Maschinenpalette hergestellt und muss separat bestellt werden!
Base plate according to your machine configuration please order extra!

Mineralgussturm mit Stahldübel
Epoxy Mineral with Steel Anchor

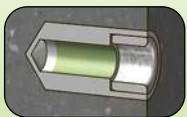

Seite / Page 250

Bestellbeispiel

Ordering example: MK350865R50 & _____ p. 274

	kg*	A	B	C	E	F	G	H	Raster / Grid
MK350865R50	~85	350	50	50	80	(40)	(690)	650	48 x M12/12F7
MK350870R50	~92	350	50	50	80	(40)	(740)	700	52 x M12/12F7
MK350875R50	~99	350	50	50	80	(40)	(790)	750	56 x M12/12F7
MK350880R50	~105	350	50	50	80	(40)	(840)	800	60 x M12/12F7
MK350885R50	~112	350	50	50	80	(40)	(890)	850	64 x M12/12F7
MK350890R50	~118	350	50	50	80	(40)	(940)	900	68 x M12/12F7
MK350895R50	~125	350	50	50	80	(40)	(990)	950	72 x M12/12F7

* Gewicht ohne Grundplatte! / Weight without baseplate!

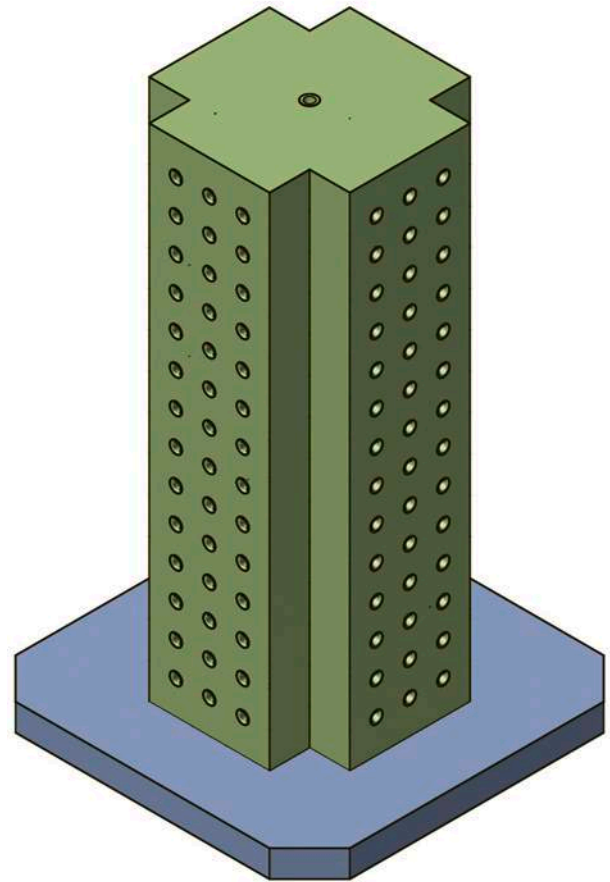
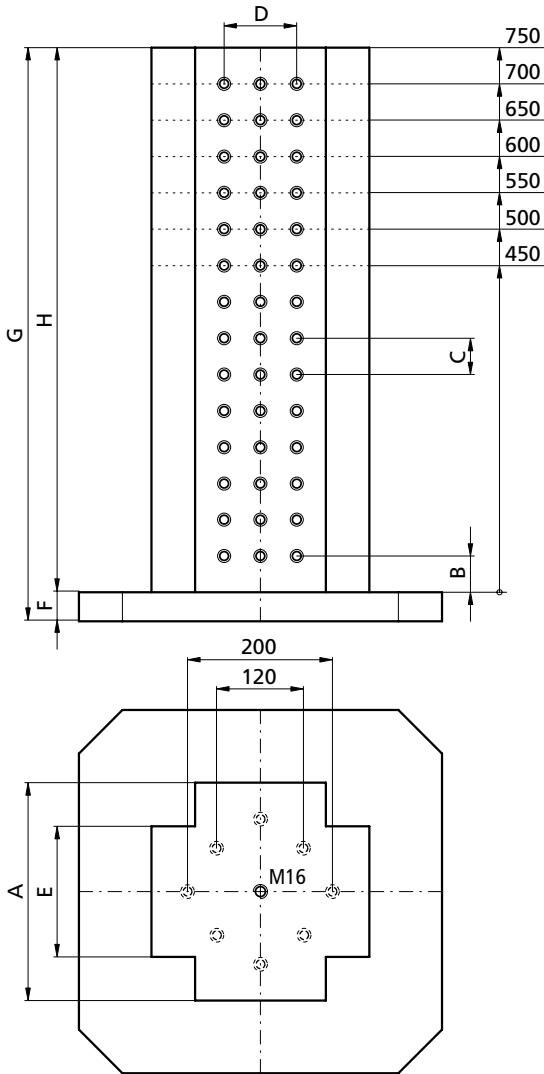

Grundplatte wird passend zu Ihrer Maschinenpalette hergestellt und muss separat bestellt werden!

Base plate according to your machine configuration please order extra!

p. 274

Mineralgussturm mit
Stahldübel
Epoxy Mineral with
Steel Anchor

Stahl-Mineralguss
Steel-epoxy mineral
tombstones

Seite / Page 250

Bestellbeispiel
Ordering example: MK301850R50 &

	kg*		kg*	A	B	C	D	E	F	G	H	Raster / Grid
MK301845R50	~77	SMK301845R50	~100	300	50	50	100	180	(40)	(440)	450	96xM12/12F7
MK301850R50	~86	SMK301850R50	~110	300	50	50	100	180	(40)	(540)	500	108xM12/12F7
MK301855R50	~94	SMK301855R50	~120	300	50	50	100	180	(40)	(590)	550	120xM12/12F7
MK301860R50	~102	SMK301860R50	~132	300	50	50	100	180	(40)	(640)	600	132xM12/12F7
MK301865R50	~110	SMK301865R50	~141	300	50	50	100	180	(40)	(690)	650	144xM12/12F7
MK301870R50	~117	SMK301870R50	~152	300	50	50	100	180	(40)	(740)	700	156xM12/12F7
MK301875R50	~125	SMK301875R50	~162	300	50	50	100	180	(40)	(790)	750	168xM12/12F7

* Gewicht ohne Grundplatte! / Weight without baseplate!

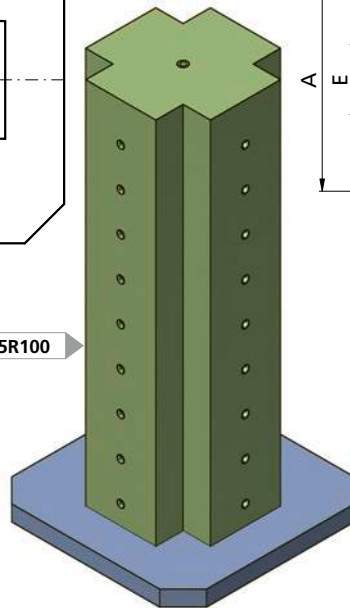
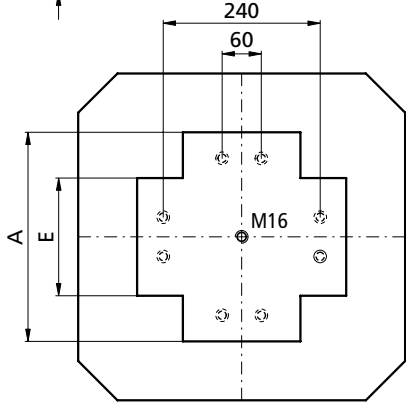
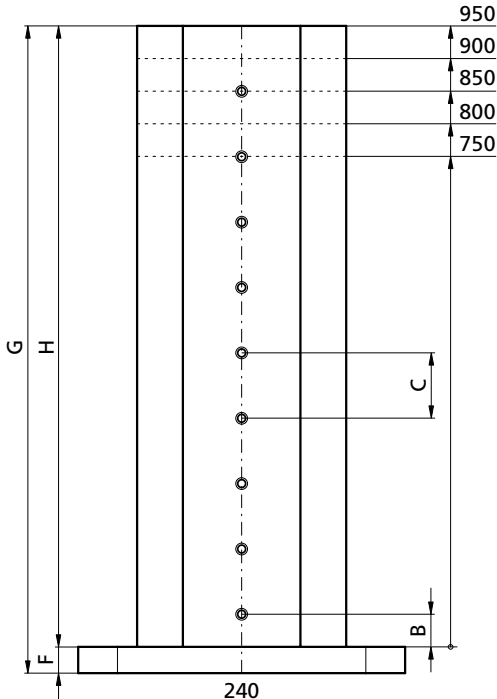

MK321895R100

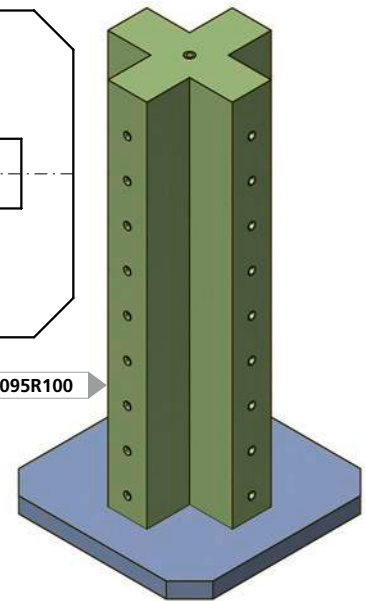
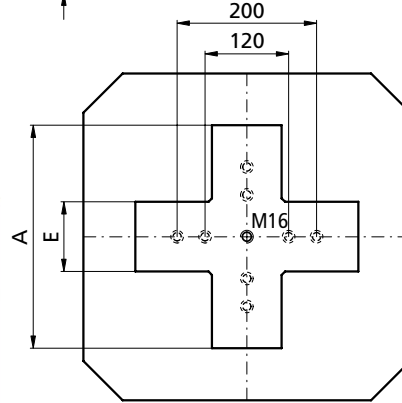
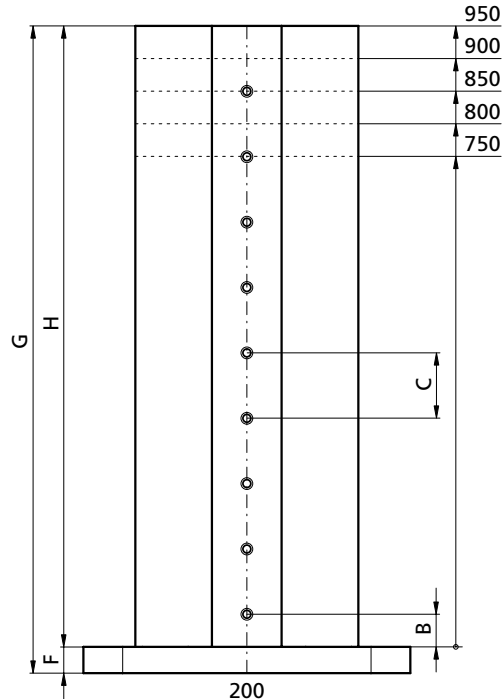

MK321095R100

Grundplatte wird passend zu Ihrer Maschinenpalette hergestellt und muss separat bestellt werden!
Base plate according to your machine configuration please order extra!

Mineralgussturm mit Stahldübel
Epoxy Mineral with Steel Anchor

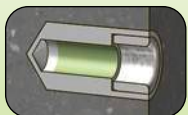

Seite / Page 250

Bestellbeispiel
Ordering example: MK321075R100 & p. 274

	kg*	A	B	C	E	F	G	H	Raster / Grid
MK321075R100	~101	320	50	100	100	(40)	(790)	750	20 x M12/12F7
MK321080R100	~108	320	50	100	100	(40)	(840)	800	24 x M12/12F7
MK321085R100	~115	320	50	100	100	(40)	(890)	850	28 x M12/12F7
MK321090R100	~121	320	50	100	100	(40)	(940)	900	32 x M12/12F7
MK321095R100	~128	320	50	100	100	(40)	(990)	950	36 x M12/12F7
MK321875R100	~106	320	50	100	180	(40)	(790)	750	20 x M12/12F7
MK321880R100	~116	320	50	100	180	(40)	(840)	800	24 x M12/12F7
MK321885R100	~126	320	50	100	180	(40)	(890)	850	28 x M12/12F7
MK321890R100	~135	320	50	100	180	(40)	(940)	900	32 x M12/12F7
MK321895R100	~145	320	50	100	180	(40)	(990)	950	36 x M12/12F7

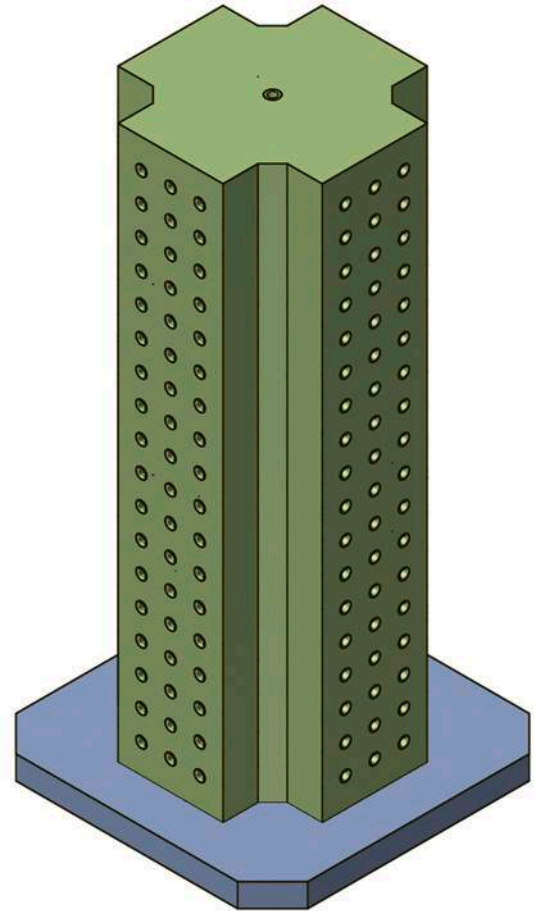
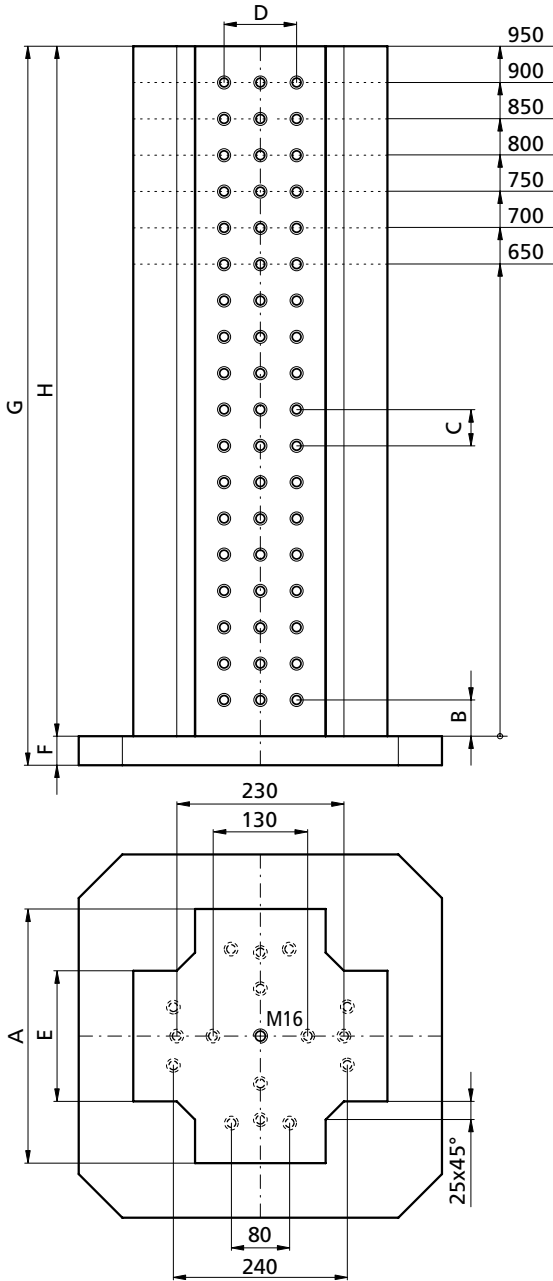

Grundplatte wird passend zu Ihrer Maschinenpalette hergestellt und muss separat bestellt werden!
Base plate according to your machine configuration please order extra!

p. 274

Mineralgussturm mit
Stahldübel
Epoxy Mineral with
Steel Anchor

Stahl-Mineralguss
Steel-epoxy mineral
tombstones

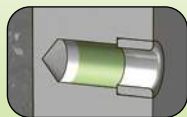
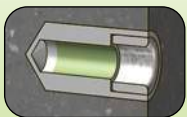

kg*

kg*

Seite / Page 250

Bestellbeispiel
Ordering example: **MK351865R50** &

					A	B	C	D	E	F	G	H	Raster / Grid
MK351865R50	~134	SMK351865R50	~165		350	50	50	100	180	(40)	(690)	650	144 x M12/12F7
MK351870R50	~144	SMK351870R50	~180		350	50	50	100	180	(40)	(740)	700	156 x M12/12F7
MK351875R50	~153	SMK351875R50	~190		350	50	50	100	180	(40)	(790)	750	168 x M12/12F7
MK351880R50	~163	SMK351880R50	~205		350	50	50	100	180	(40)	(840)	800	180 x M12/12F7
MK351885R50	~172	SMK351885R50	~215		350	50	50	100	180	(40)	(890)	850	192 x M12/12F7
MK351890R50	~182	SMK351890R50	~230		350	50	50	100	180	(40)	(940)	900	204 x M12/12F7
MK351895R50	~191	SMK351895R50	~240		350	50	50	100	180	(40)	(990)	950	216 x M12/12F7

* Gewicht ohne Grundplatte! / Weight without baseplate!

MK4018 ... R50

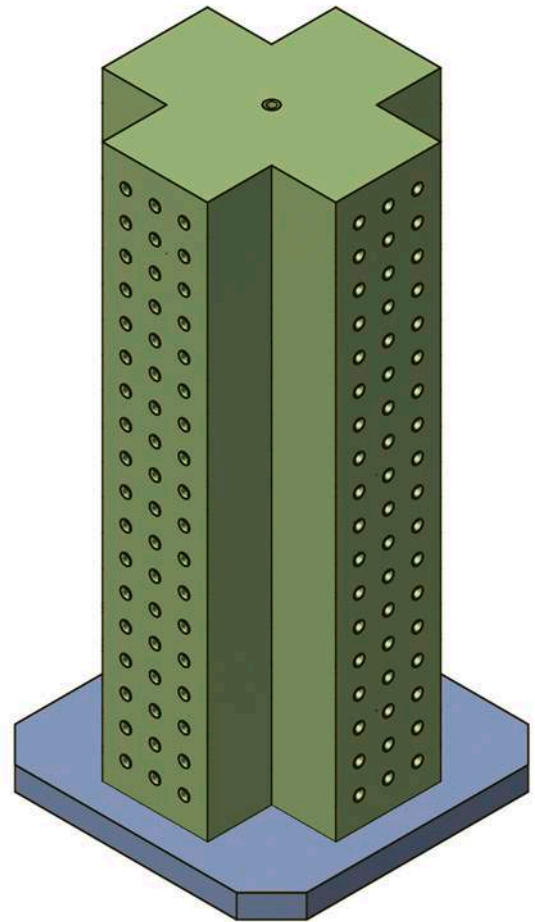
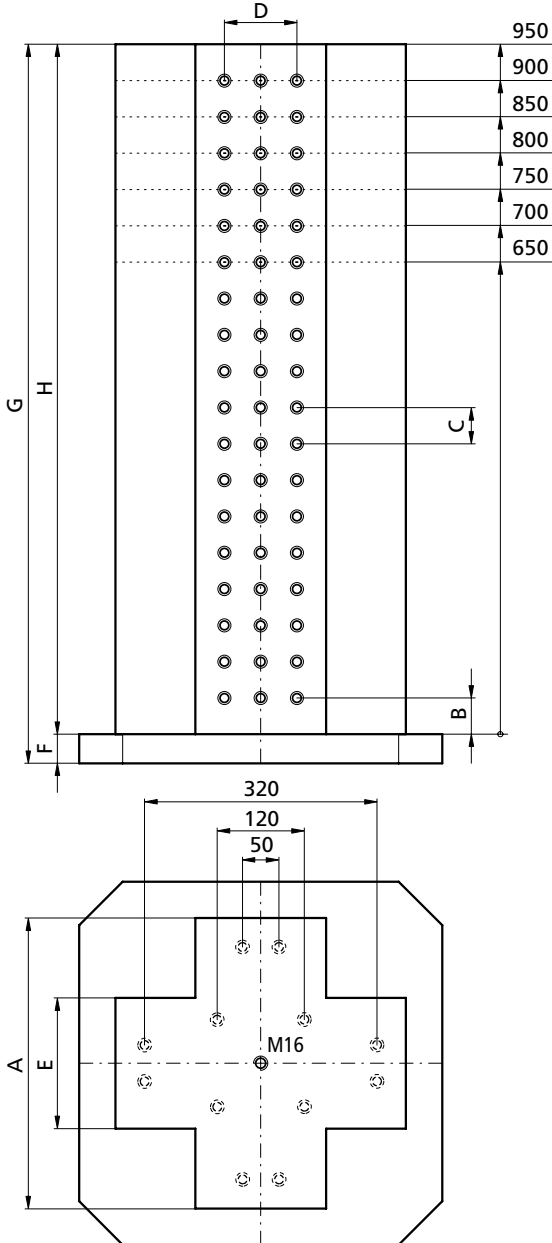

Grundplatte wird passend zu Ihrer Maschinenpalette hergestellt und muss separat bestellt werden!
Base plate according to your machine configuration please order extra!

p. 274

Mineralgussturm mit Stahldübel
Epoxy Mineral with Steel Anchor

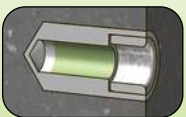

Seite / Page 250

Bestellbeispiel
Ordering example: **MK401865R50** &

	kg*	A	B	C	D	E	F	G	H	Raster / Grid
MK401865R50	~161	400	50	50	100	180	(40)	(690)	650	144 x M12/12F7
MK401870R50	~172	400	50	50	100	180	(40)	(740)	700	156 x M12/12F7
MK401875R50	~184	400	50	50	100	180	(40)	(790)	750	168 x M12/12F7
MK401880R50	~195	400	50	50	100	180	(40)	(840)	800	180 x M12/12F7
MK401885R50	~207	400	50	50	100	180	(40)	(890)	850	192 x M12/12F7
MK401890R50	~218	400	50	50	100	180	(40)	(940)	900	204 x M12/12F7
MK401895R50	~230	400	50	50	100	180	(40)	(990)	950	216 x M12/12F7

* Gewicht ohne Grundplatte! / Weight without baseplate!

Art. Nr.	kg	Raster / Grid	H
MQ161630R50	~19	20 x M12/12F7	300
MQ161635R50	~22	24 x M12/12F7	350
MQ161640R50	~25	28 x M12/12F7	400
MQ161645R50	~28	32 x M12/12F7	450
MQ161650R50	~31	36 x M12/12F7	500

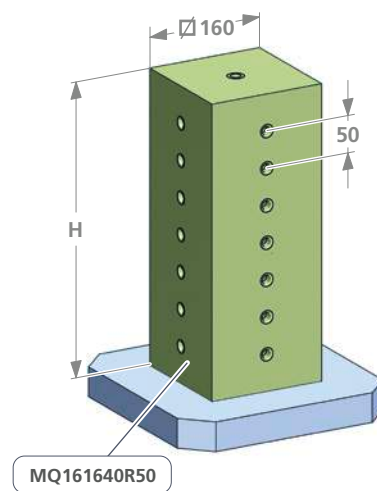

*Maschinenschonend und leicht,
fast in allen Formen herstellbar.*

*Reduces machine wear due to low
specific weight - can be produced in
all sorts of shapes.*

Mineralgussturm Mineral tombstone



tripoxyMINERAL

Art. Nr.	kg	Raster / Grid	H
MQ202040R50	~42	84 x M12/12F7	400
MQ202045R50	~53	96 x M12/12F7	450
MQ202050R50	~59	108 x M12/12F7	500
MQ202055R50	~64	120 x M12/12F7	550
MQ202060R50	~70	132 x M12/12F7	600
MQ202065R50	~76	144 x M12/12F7	650
MQ202070R50	~81	156 x M12/12F7	700
MQ242450R50	~81	108 x M12/12F7	500
MQ242455R50	~89	120 x M12/12F7	550
MQ242460R50	~97	132 x M12/12F7	600
MQ242465R50	~103	144 x M12/12F7	650

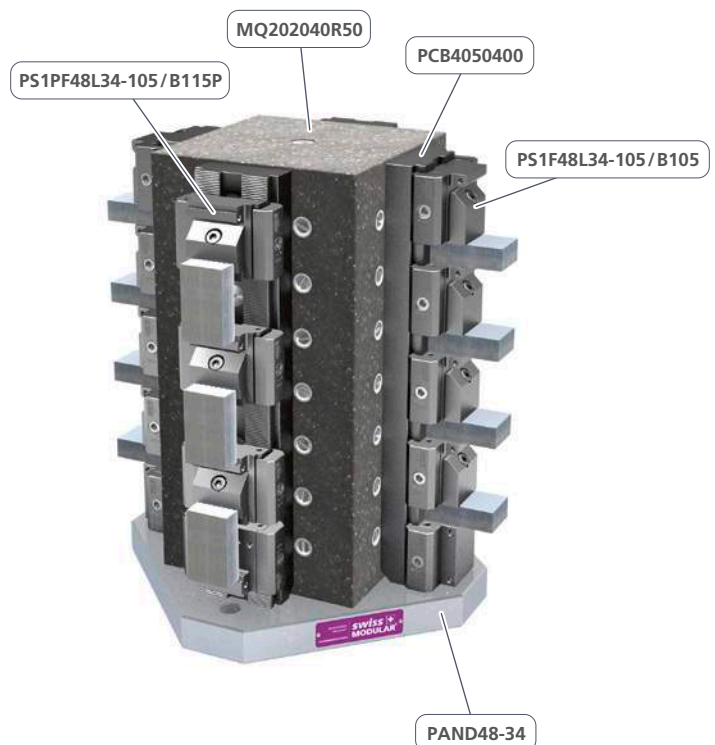
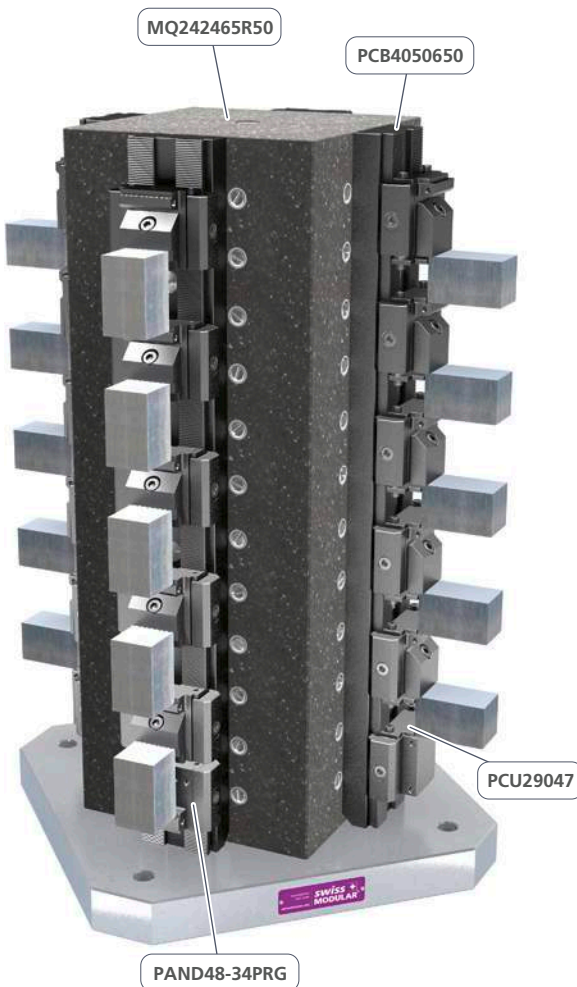
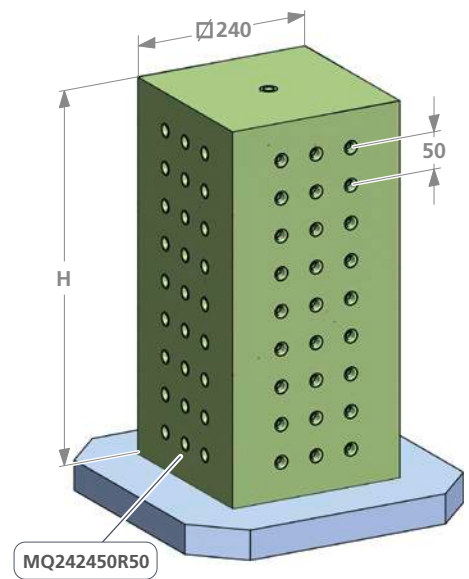
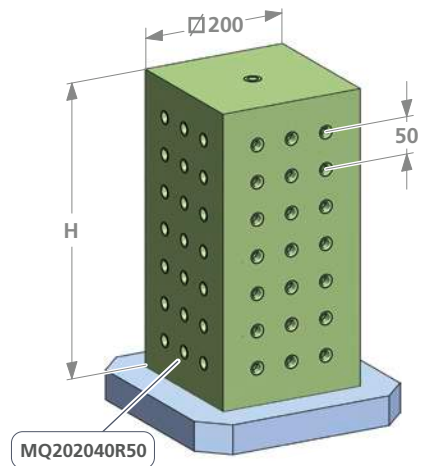

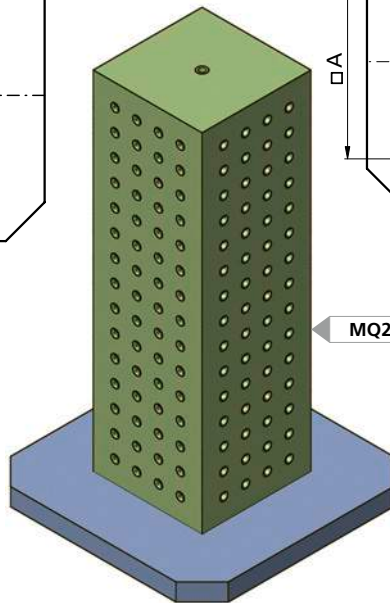
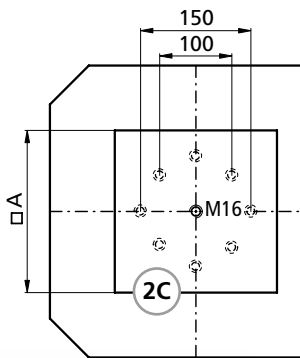
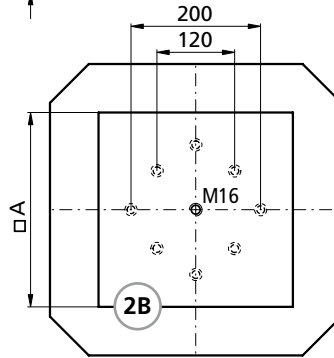
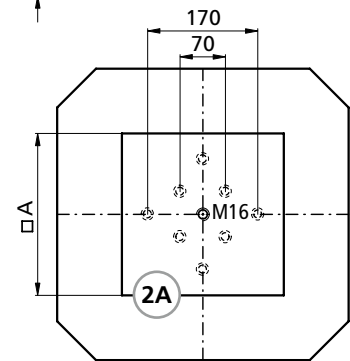
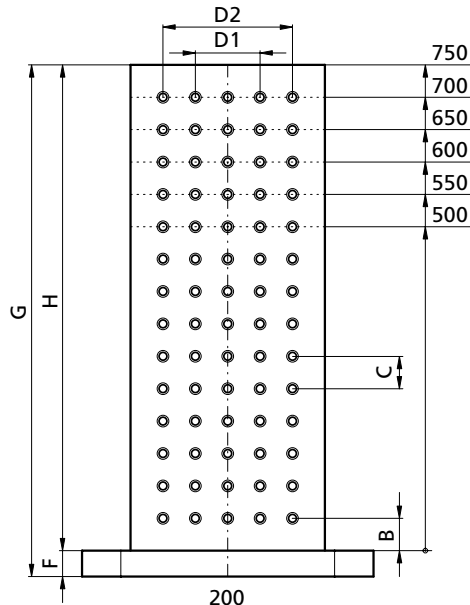
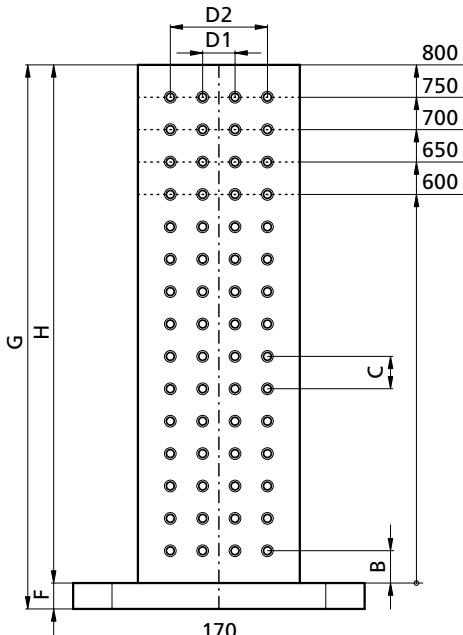

MQ303075R50

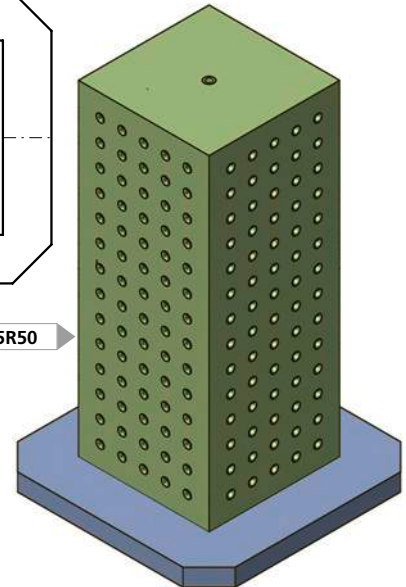

Grundplatte wird passend zu Ihrer Maschinenpalette hergestellt und muss separat bestellt werden!
Base plate according to your machine configuration please order extra!

p. 274

Mineralgussturm mit
Stahldübel
Epoxy Mineral with
Steel Anchor

Seite / Page 250

Bestellbeispiel
Ordering example: MQ252560R50 &

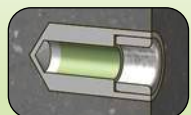

kg*

		Bohrbild Hole pattern	A	B	C	D1	D2	F	G	H	Raster / Grid
MQ252560R50	~107	2A	250	50	50	100	150	(40)	(640)	600	176 x M12/12F7
MQ252565R50	~116	2A	250	50	50	100	150	(40)	(690)	650	192 x M12/12F7
MQ252570R50	~125	2A	250	50	50	100	150	(40)	(740)	700	208 x M12/12F7
MQ252575R50	~134	2C	250	50	50	100	150	(40)	(790)	750	224 x M12/12F7
MQ252580R50	~143	2C	250	50	50	100	150	(40)	(840)	800	240 x M12/12F7
MQ303050R50	~109	2B	300	50	50	100	200	(40)	(540)	500	180 x M12/12F7
MQ303055R50	~119	2B	300	50	50	100	200	(40)	(590)	550	200 x M12/12F7
MQ303060R50	~129	2B	300	50	50	100	200	(40)	(640)	600	220 x M12/12F7
MQ303065R50	~139	2B	300	50	50	100	200	(40)	(690)	650	240 x M12/12F7
MQ303070R50	~149	2B	300	50	50	100	200	(40)	(740)	700	260 x M12/12F7
MQ303075R50	~162	2B	300	50	50	100	200	(40)	(790)	750	280 x M12/12F7

* Gewicht ohne Grundplatte! / Weight without baseplate!

MQ4040 ... R50

MQ3535 ... R50



tripoxyMINERAL

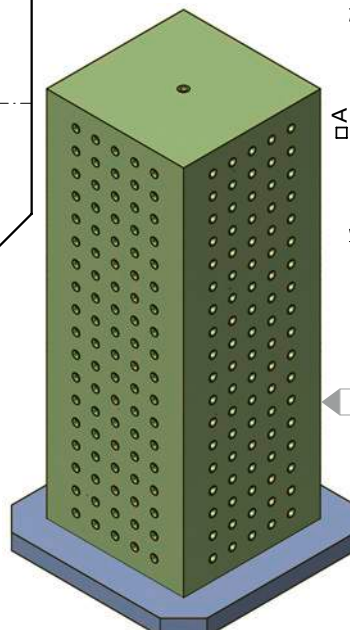
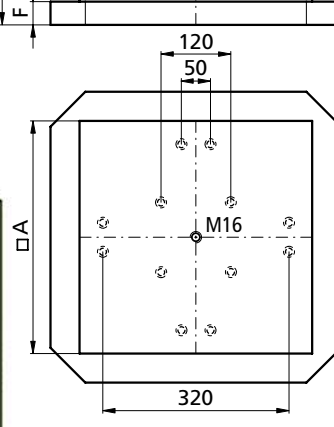
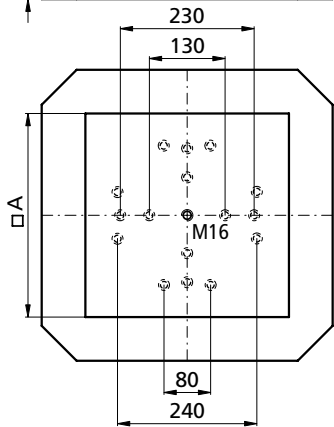
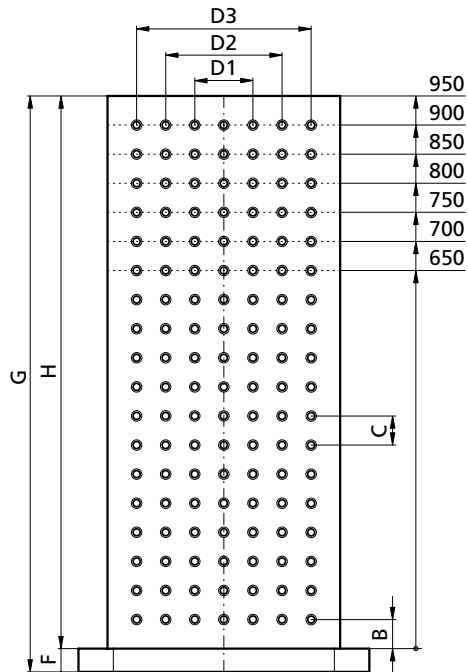
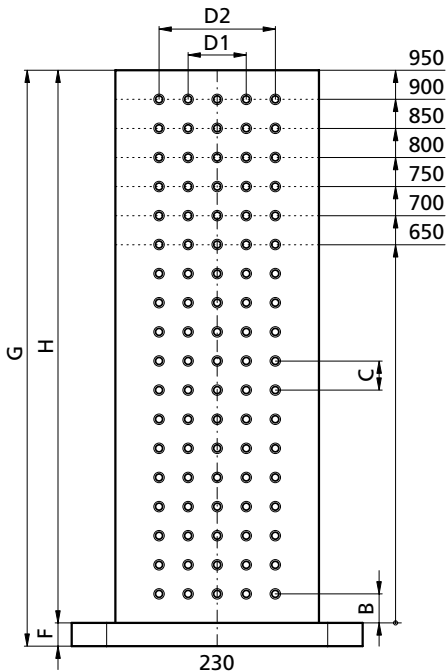

MQ353595R50

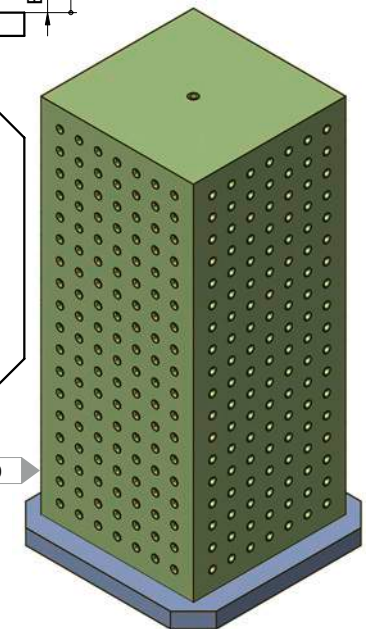

MQ404095R50

Mineralgussturm mit
Stahldübel
Epoxy Mineral with
Steel Anchor

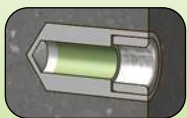

Seite / Page 250

Bestellbeispiel
Ordering example: **MQ353565R50** & _____

p. 274

Grundplatte wird passend
zu Ihrer Maschinenpalette
hergestellt und muss separat
bestellt werden!
Base plate according to your
machine configuration please
order extra!

	kg*	A	B	C	D1	D2	D3	F	G	H	Raster / Grid
MQ353565R50	~175	350	50	50	100	200		(40)	(690)	650	240 x M12/12F7
MQ353570R50	~187	350	50	50	100	200		(40)	(740)	700	260 x M12/12F7
MQ353575R50	~200	350	50	50	100	200		(40)	(790)	750	280 x M12/12F7
MQ353580R50	~213	350	50	50	100	200		(40)	(840)	800	300 x M12/12F7
MQ353585R50	~225	350	50	50	100	200		(40)	(890)	850	320 x M12/12F7
MQ353590R50	~238	350	50	50	100	200		(40)	(940)	900	340 x M12/12F7
MQ353595R50	~250	350	50	50	100	200		(40)	(990)	950	360 x M12/12F7
MQ404065R50	~217	400	50	50	100	200	300	(40)	(690)	650	336 x M12/12F7
MQ404070R50	~232	400	50	50	100	200	300	(40)	(740)	700	364 x M12/12F7
MQ404075R50	~247	400	50	50	100	200	300	(40)	(790)	750	392 x M12/12F7
MQ404080R50	~262	400	50	50	100	200	300	(40)	(840)	800	420 x M12/12F7
MQ404085R50	~277	400	50	50	100	200	300	(40)	(890)	850	448 x M12/12F7
MQ404090R50	~292	400	50	50	100	200	300	(40)	(940)	900	476 x M12/12F7
MQ404095R50	~307	400	50	50	100	200	300	(40)	(990)	950	504 x M12/12F7

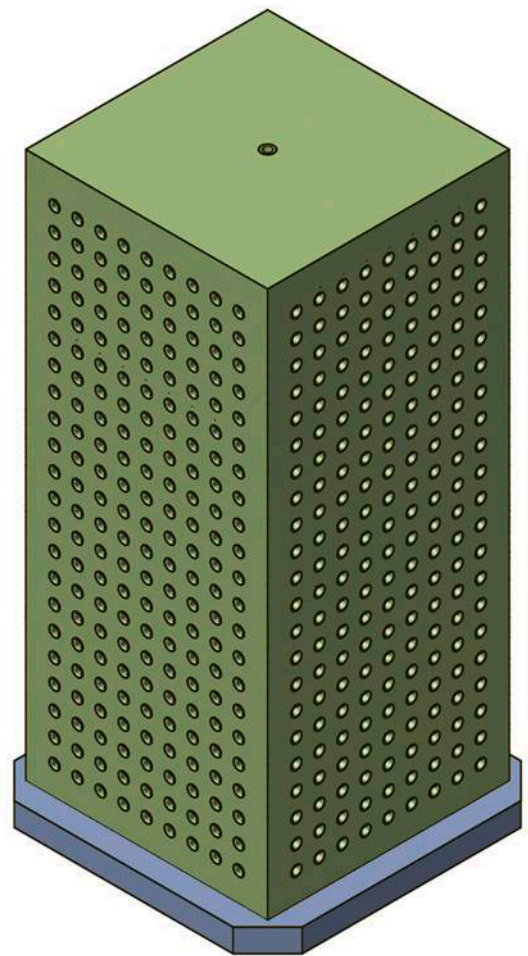
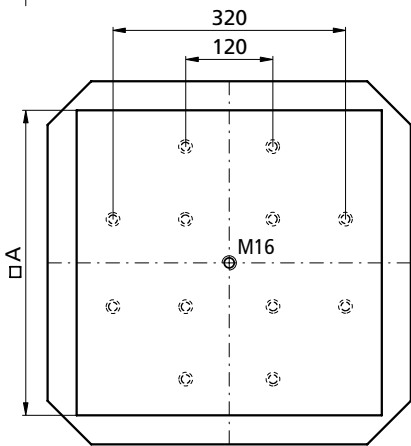
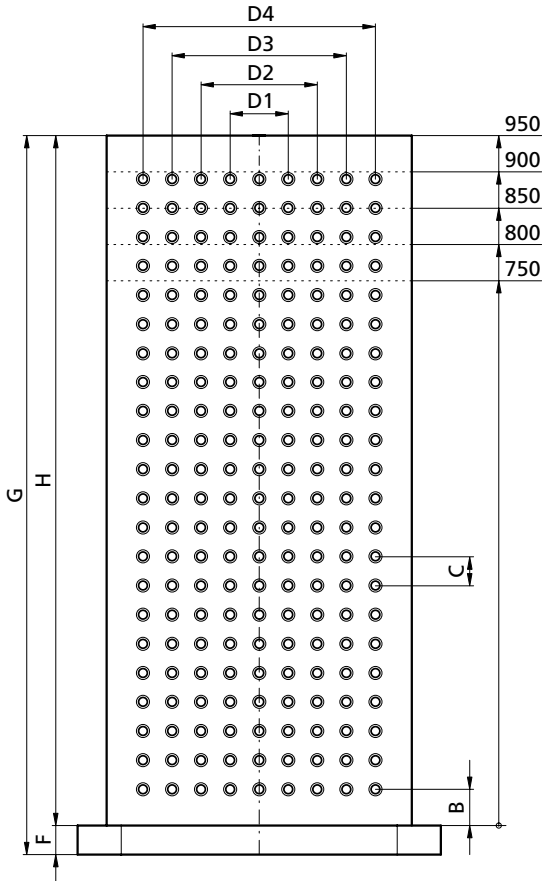

Grundplatte wird passend zu Ihrer Maschinenpalette hergestellt und muss separat bestellt werden!
Base plate according to your machine configuration please order extra!

Mineralgussturm mit Stahldübel
Epoxy Mineral with Steel Anchor

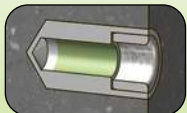

Seite / Page 250

Bestellbeispiel
Ordering example: **MQ424275R40** & _____ p. 274

	kg*	A	B	C	D1	D2	D3	D4	F	G	H	Raster / Grid
MQ424275R40	~329	420	50	40	80	160	240	320	(40)	(790)	750	612 x M12/12F7
MQ424280R40	~349	420	50	40	80	160	240	320	(40)	(840)	800	648 x M12/12F7
MQ424285R40	~373	420	50	40	80	160	240	320	(40)	(890)	850	684 x M12/12F7
MQ424290R40	~393	420	50	40	80	160	240	320	(40)	(940)	900	720 x M12/12F7
MQ424295R40	~413	420	50	40	80	160	240	320	(40)	(990)	950	756 x M12/12F7

* Gewicht ohne Grundplatte! / Weight without baseplate!

MR3015 ... R50

MR4012 ... R50

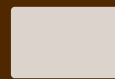

Rechteck
Rectangle

tripoxyMINERAL

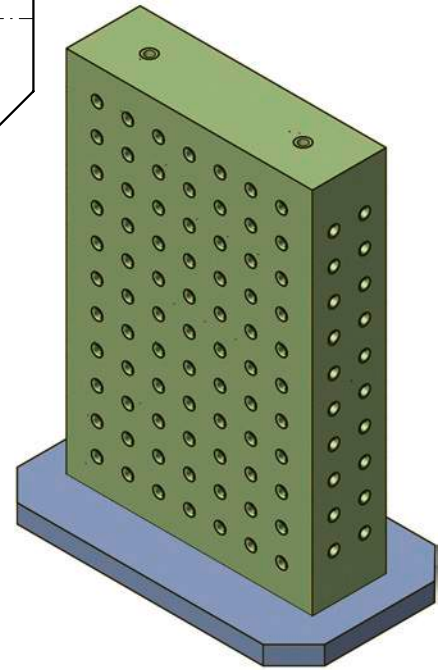
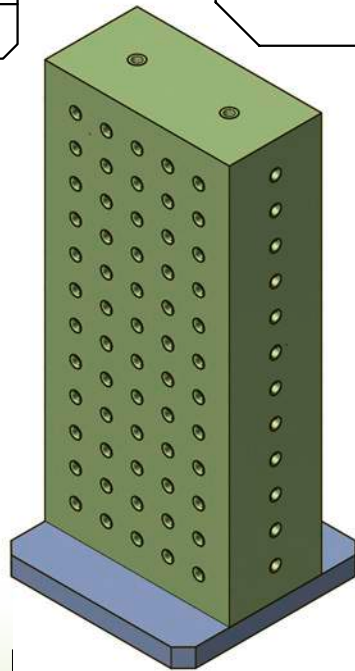
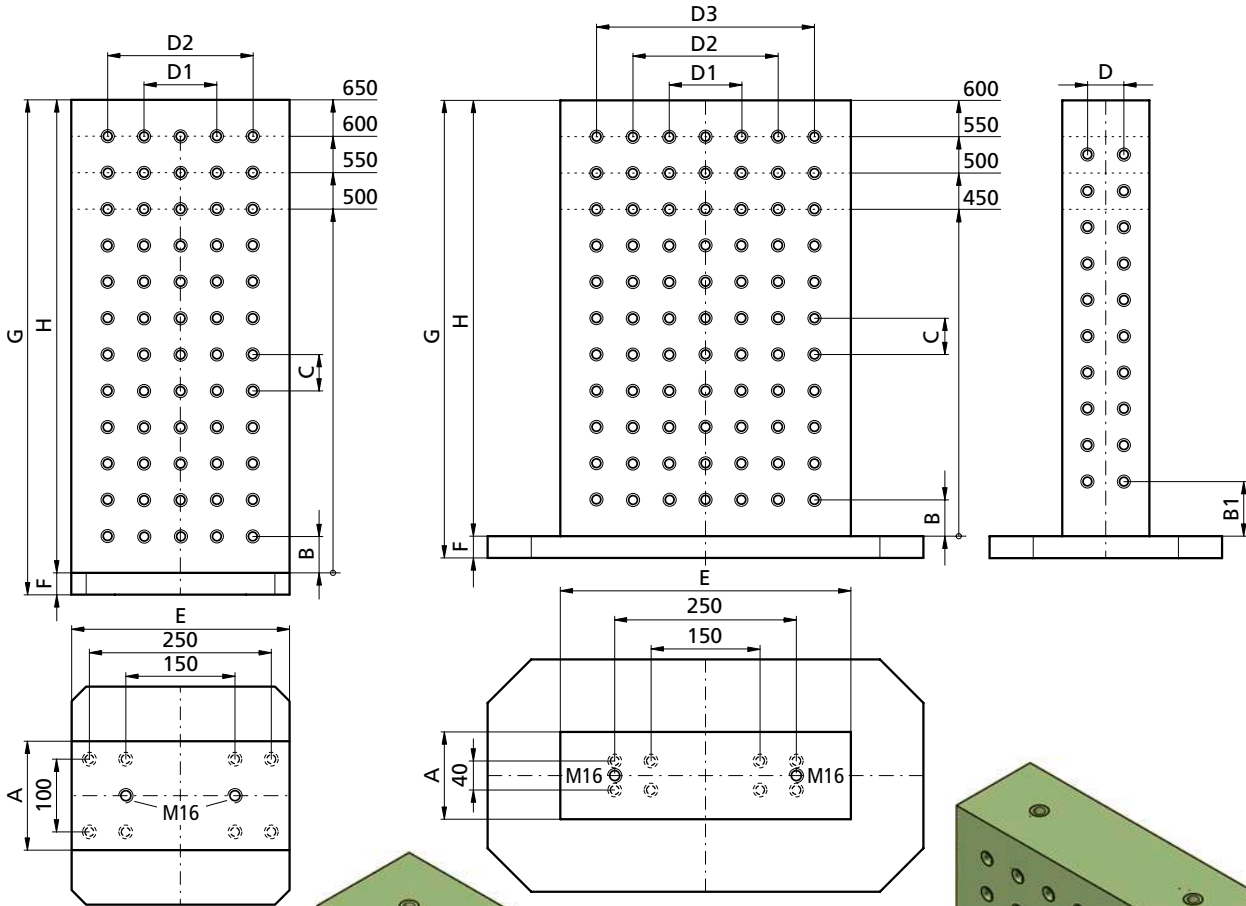

Mineralgussturm mit
Stahldübel
Epoxy Mineral with
Steel Anchor

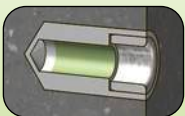

Seite / Page 250

Bestellbeispiel

Ordering example: **MR401245R50** &

p. 274

Grundplatte wird passend
zu Ihrer Maschinenpalette
hergestellt und muss separat
bestellt werden!

Base plate according to your
machine configuration please
order extra!

	kg*	A	B	B1	C	D	D1	D2	D3	E	F	G	H	Raster / Grid
MR301550R50	~65	150	50		50		100	200		300	(30)	(530)	500	63 x M12/12F7
MR301555R50	~72	150	50		50		100	200		300	(30)	(580)	550	70 x M12/12F7
MR301560R50	~78	150	50		50		100	200		300	(30)	(630)	600	77 x M12/12F7
MR301565R50	~85	150	50		50		100	200		300	(30)	(680)	650	84 x M12/12F7
MR401245R50	~64	120	50	75	50	50	100	200	300	400	(30)	(480)	450	140 x M12/12F7
MR401250R50	~71	120	50	75	50	50	100	200	300	400	(30)	(530)	500	158 x M12/12F7
MR401255R50	~78	120	50	75	50	50	100	200	300	400	(30)	(580)	550	176 x M12/12F7
MR401260R50	~85	120	50	75	50	50	100	200	300	400	(30)	(630)	600	194 x M12/12F7

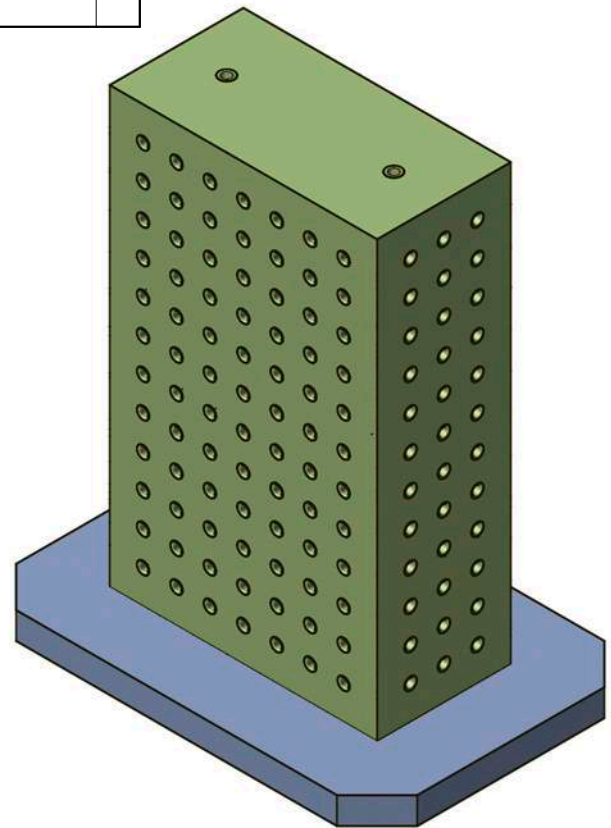
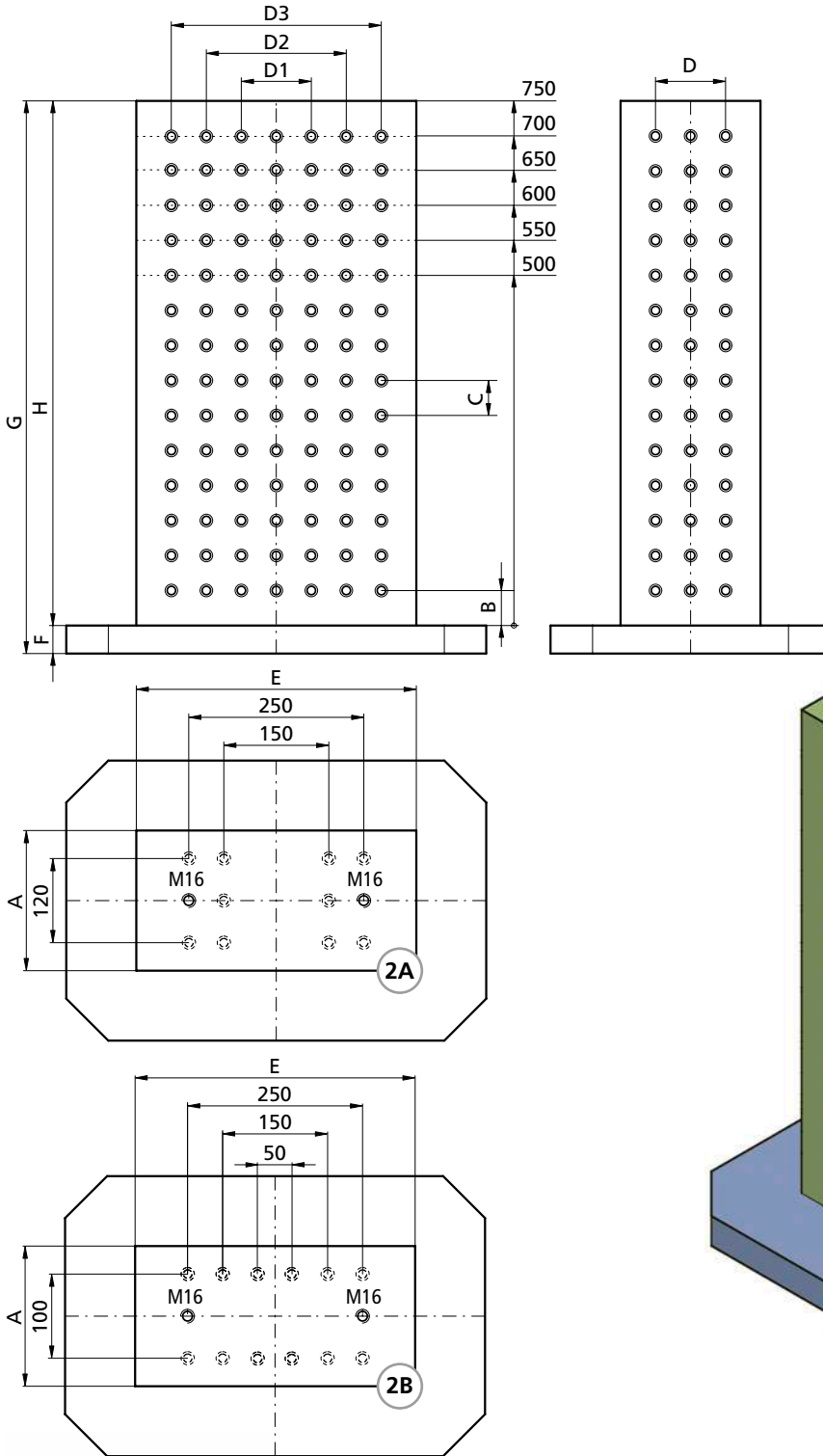

Grundplatte wird passend zu Ihrer Maschinenpalette hergestellt und muss separat bestellt werden!
Base plate according to your machine configuration please order extra!

Mineralgussturm mit Stahldübel
Epoxy Mineral with Steel Anchor

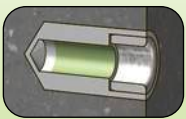

Seite / Page 250

Bestellbeispiel
Ordering example: **MR402050R50** & _____ p. 274

	kg*	Bohrbild / Hole pattern	A	B	C	D	D1	D2	D3	E	F	G	H	Raster / Grid
MR402050R50	~115	2A	200	50	50	100	100	200	300	400	(40)	(540)	500	180 x M12/12F7
MR402055R50	~126	2A	200	50	50	100	100	200	300	400	(40)	(590)	550	200 x M12/12F7
MR402060R50	~138	2A	200	50	50	100	100	200	300	400	(40)	(640)	600	220 x M12/12F7
MR402065R50	~149	2A	200	50	50	100	100	200	300	400	(40)	(690)	650	240 x M12/12F7
MR402070R50	~162	2B	200	50	50	100	100	200	300	400	(40)	(740)	700	260 x M12/12F7
MR402075R50	~172	2B	200	50	50	100	100	200	300	400	(40)	(790)	750	280 x M12/12F7

* Gewicht ohne Grundplatte! / Weight without baseplate!

MR5020 ... R50-2

MR5020 ... R50-4



Rechteck
Rectangle

tripoxyMINERAL

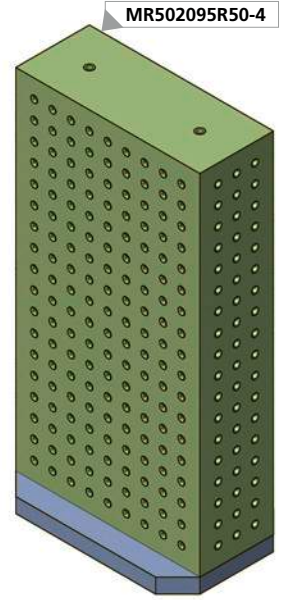
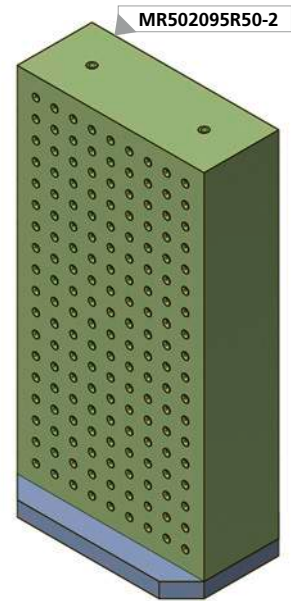
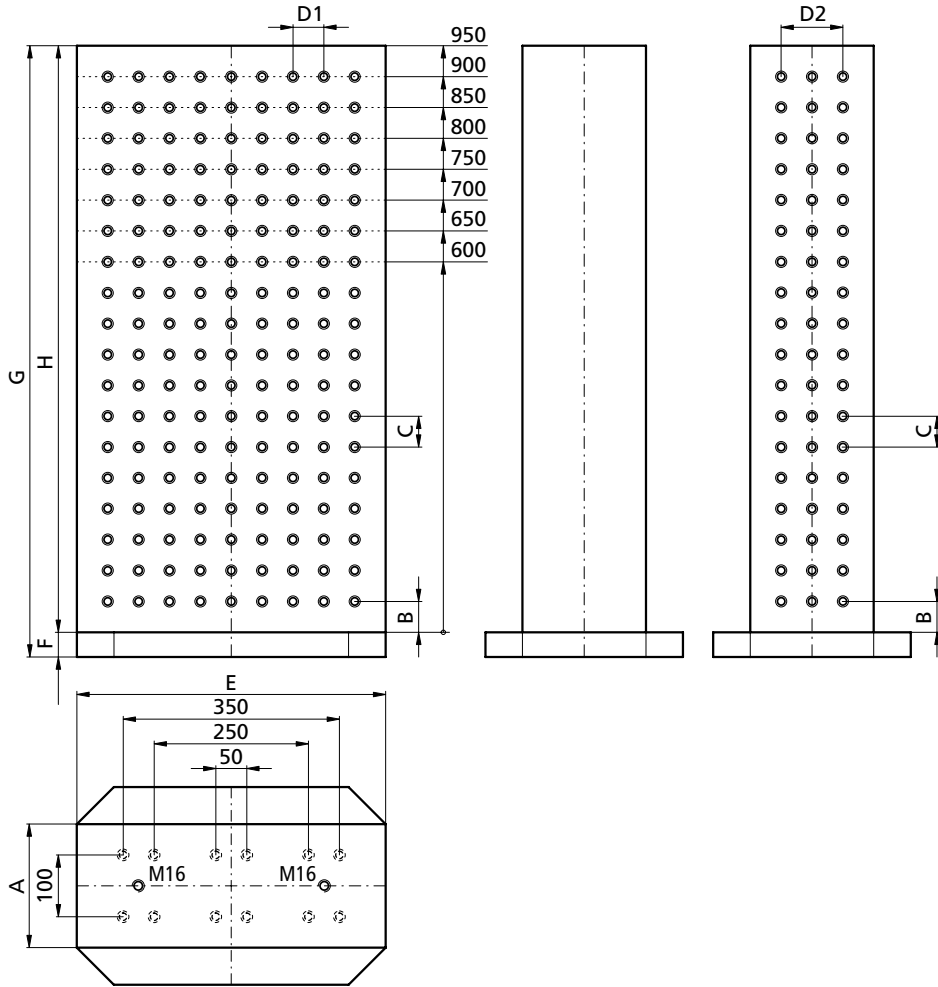

Mineralgussturm mit
Stahldübel
Epoxy Mineral with
Steel Anchor

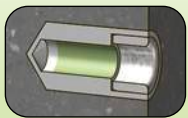

Seite / Page 250

Bestellbeispiel

Ordering example: MR502060R50-2 & _____ p. 274

Grundplatte wird passend
zu Ihrer Maschinenpalette
hergestellt und muss separat
bestellt werden!
Base plate according to your
machine configuration please
order extra!

	kg*	A	B	C	D1	D2	E	F	G	H	Raster / Grid
MR502060R50-2	~165	200	50	50	50		500	(40)	(640)	600	198 x M12/12F7
MR502065R50-2	~179	200	50	50	50		500	(40)	(690)	650	216 x M12/12F7
MR502070R50-2	~193	200	50	50	50		500	(40)	(740)	700	234 x M12/12F7
MR502075R50-2	~208	200	50	50	50		500	(40)	(790)	750	252 x M12/12F7
MR502080R50-2	~222	200	50	50	50		500	(40)	(840)	800	270 x M12/12F7
MR502085R50-2	~236	200	50	50	50		500	(40)	(890)	850	288 x M12/12F7
MR502090R50-2	~251	200	50	50	50		500	(40)	(940)	900	306 x M12/12F7
MR502095R50-2	~265	200	50	50	50		500	(40)	(990)	950	324 x M12/12F7
MR502060R50-4	~171	200	50	50	50	100	500	(40)	(640)	600	264 x M12/12F7
MR502065R50-4	~185	200	50	50	50	100	500	(40)	(690)	650	288 x M12/12F7
MR502070R50-4	~199	200	50	50	50	100	500	(40)	(740)	700	312 x M12/12F7
MR502075R50-4	~214	200	50	50	50	100	500	(40)	(790)	750	336 x M12/12F7
MR502080R50-4	~228	200	50	50	50	100	500	(40)	(840)	800	360 x M12/12F7
MR502085R50-4	~242	200	50	50	50	100	500	(40)	(890)	850	384 x M12/12F7
MR502090R50-4	~257	200	50	50	50	100	500	(40)	(940)	900	408 x M12/12F7
MR502095R50-4	~271	200	50	50	50	100	500	(40)	(990)	950	432 x M12/12F7

MR6020 ... R50-2

MR6020 ... R50-4

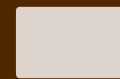

Rechteck
Rectangle

tripoxyMINERAL

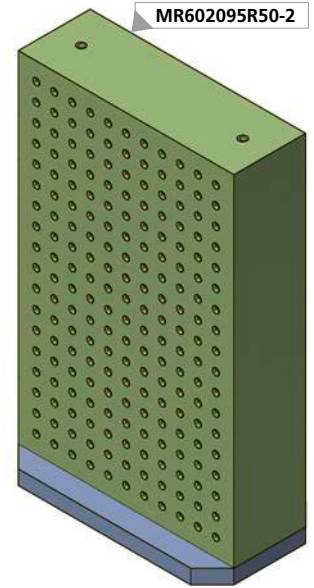
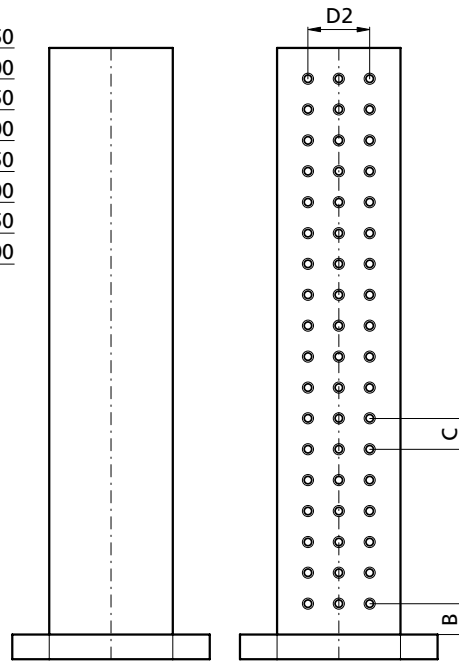
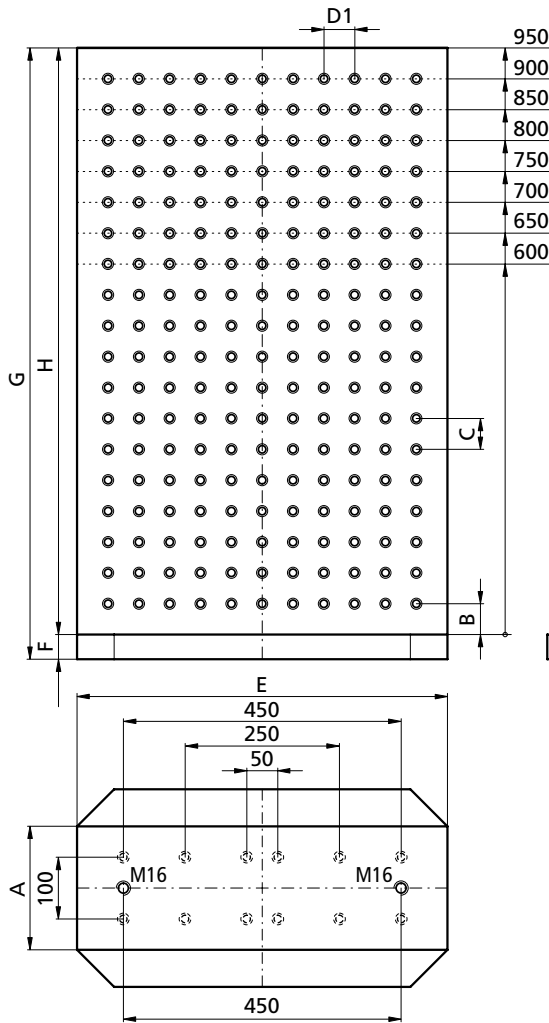

MR602095R50-2

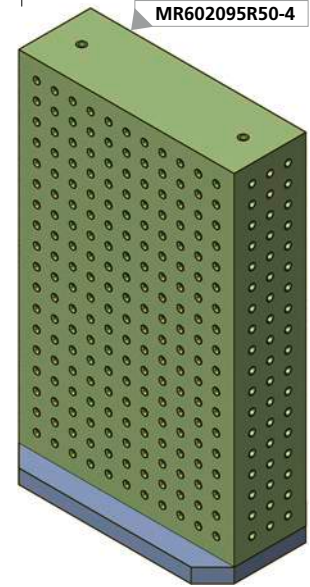

MR602095R50-4

Mineralgussturm mit
Stahldübel
Epoxy Mineral with
Steel Anchor

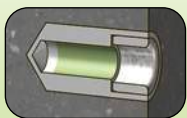

Seite / Page 250

Bestellbeispiel

Ordering example: MR602060R50-2 & _____ p. 274

Grundplatte wird passend
zu Ihrer Maschinenpalette
hergestellt und muss separat
bestellt werden!
Base plate according to your
machine configuration please
order extra!

	kg*	A	B	C	D1	D2	E	F	G	H	Raster / Grid
MR602060R50-2	~200	200	50	50	50		600	(40)	(640)	600	242 x M12/12F7
MR602065R50-2	~217	200	50	50	50		600	(40)	(690)	650	264 x M12/12F7
MR602070R50-2	~234	200	50	50	50		600	(40)	(740)	700	286 x M12/12F7
MR602075R50-2	~250	200	50	50	50		600	(40)	(790)	750	308 x M12/12F7
MR602080R50-2	~267	200	50	50	50		600	(40)	(840)	800	330 x M12/12F7
MR602085R50-2	~284	200	50	50	50		600	(40)	(890)	850	352 x M12/12F7
MR602090R50-2	~301	200	50	50	50		600	(40)	(940)	900	374 x M12/12F7
MR602095R50-2	~317	200	50	50	50		600	(40)	(990)	950	396 x M12/12F7
MR602060R50-4	~205	200	50	50	50	100	600	(40)	(640)	600	308 x M12/12F7
MR602065R50-4	~222	200	50	50	50	100	600	(40)	(690)	650	330 x M12/12F7
MR602070R50-4	~239	200	50	50	50	100	600	(40)	(740)	700	364 x M12/12F7
MR602075R50-4	~256	200	50	50	50	100	600	(40)	(790)	750	392 x M12/12F7
MR602080R50-4	~273	200	50	50	50	100	600	(40)	(840)	800	420 x M12/12F7
MR602085R50-4	~290	200	50	50	50	100	600	(40)	(890)	850	448 x M12/12F7
MR602090R50-4	~307	200	50	50	50	100	600	(40)	(940)	900	476 x M12/12F7
MR602095R50-4	~324	200	50	50	50	100	600	(40)	(990)	950	504 x M12/12F7

* Gewicht ohne Grundplatte! / Weight without baseplate!

Separat bestellen / Order separately

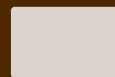

Rechteck
Rectangle

MR6330 ... R40

tripoxyMINERAL

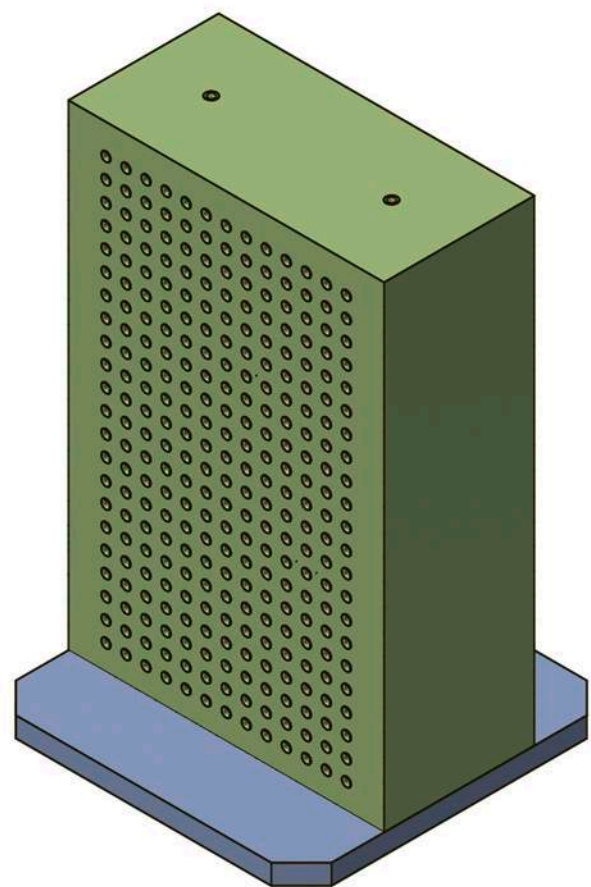
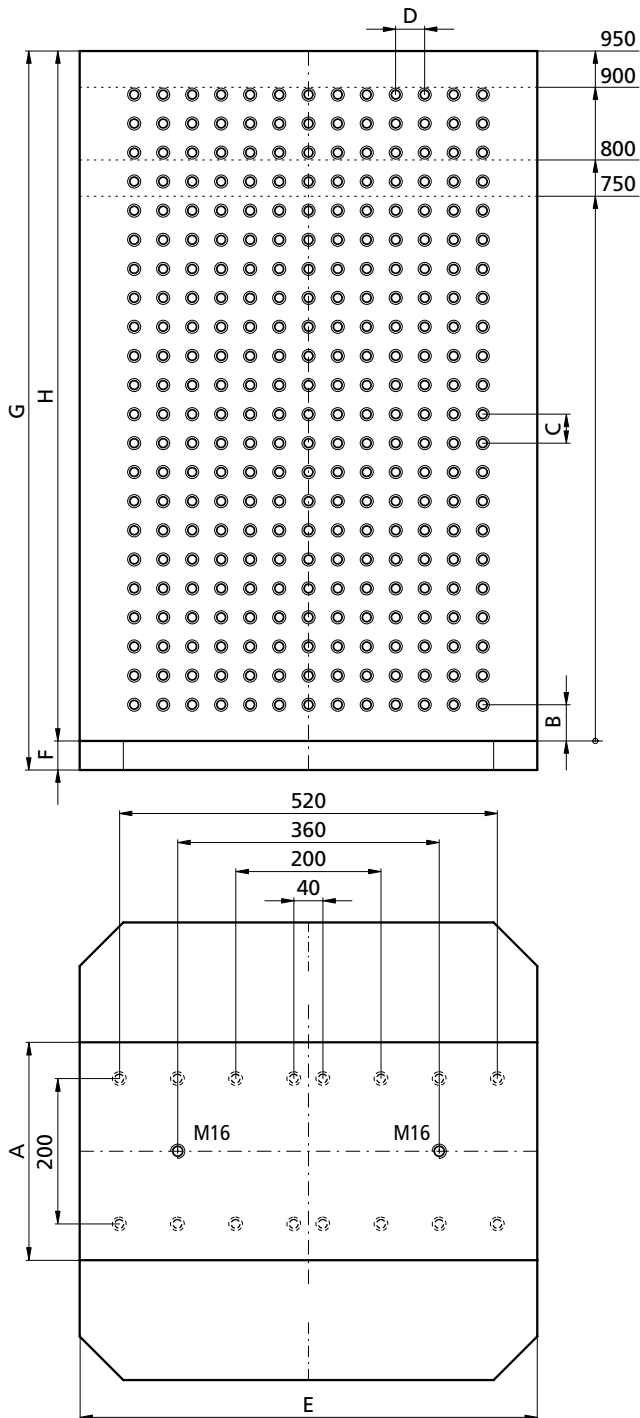

Grundplatte wird passend zu Ihrer Maschinenpalette hergestellt und muss separat bestellt werden!
Base plate according to your machine configuration please order extra!

Mineralgussturm mit
Stahldübel
Epoxy Mineral with
Steel Anchor

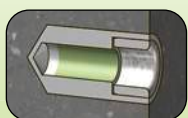

Seite / Page 250

Bestellbeispiel

Ordering example: **MR633075R40** & _____ p. 274

	kg*	A	B	C	D	E	F	G	H	Raster / Grid
MR633075R40	~314	300	50	40	40	630	(40)	(790)	750	468 x M12/12F7
MR633080R40	~333	300	50	40	40	630	(40)	(840)	800	494 x M12/12F7
MR633090R40	~374	300	50	40	40	630	(40)	(940)	900	546 x M12/12F7
MR633095R40	~393	300	50	40	40	630	(40)	(990)	950	572 x M12/12F7



Rechteck
Rectangle

MR7015 ... R50

tripoxyMINERAL

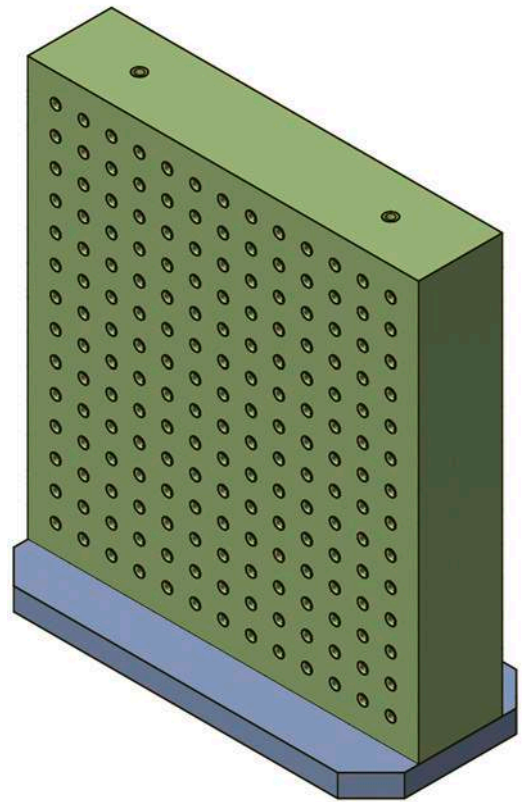
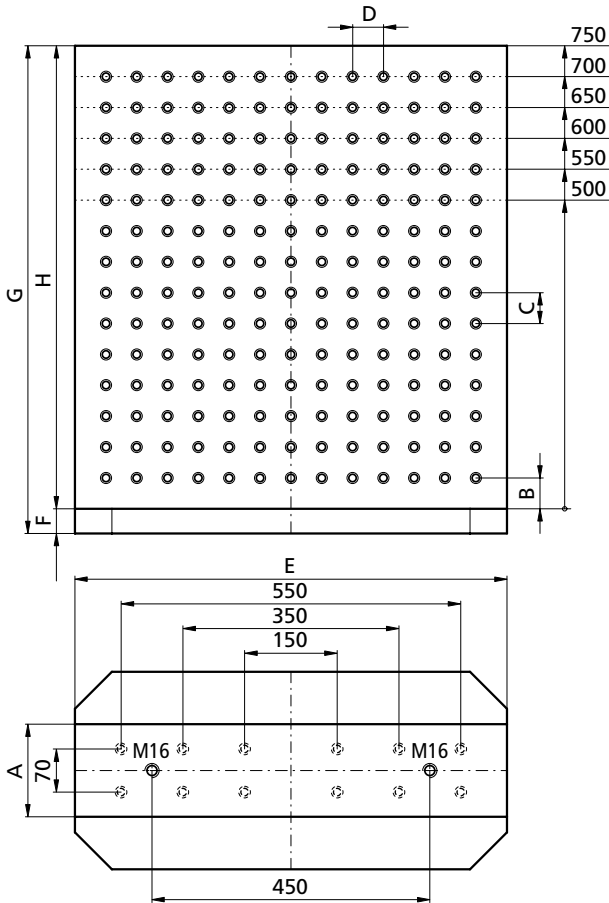

Grundplatte wird passend zu Ihrer Maschinenpalette hergestellt und muss separat bestellt werden!
Base plate according to your machine configuration please order extra!

Mineralgussturm mit Stahldübel
Epoxy Mineral with Steel Anchor

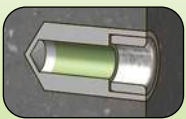

Seite / Page 250

Bestellbeispiel
Ordering example: MR701550R50 & _____ p. 274

	kg*	A	B	C	D	E	F	G	H	Raster / Grid
MR701550R50	~153	150	50	50	50	700	(40)	(540)	500	234 x M12/12F7
MR701555R50	~168	150	50	50	50	700	(40)	(590)	550	260 x M12/12F7
MR701560R50	~183	150	50	50	50	700	(40)	(640)	600	286 x M12/12F7
MR701565R50	~199	150	50	50	50	700	(40)	(690)	650	312 x M12/12F7
MR701570R50	~214	150	50	50	50	700	(40)	(740)	700	338 x M12/12F7
MR701575R50	~229	150	50	50	50	700	(40)	(790)	750	364 x M12/12F7

* Gewicht ohne Grundplatte! / Weight without baseplate!

Separat bestellen / Order separately

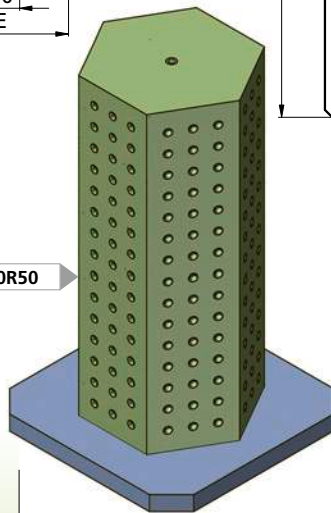
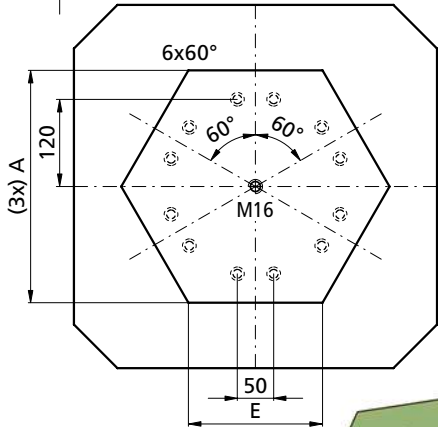
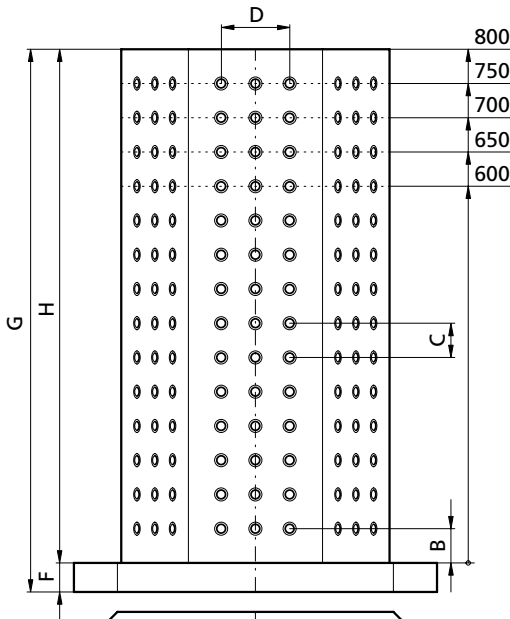

MS321980R50

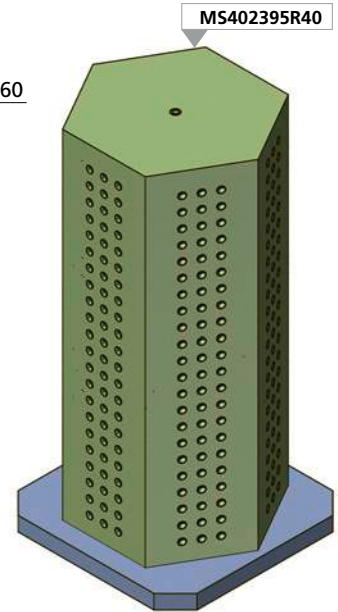
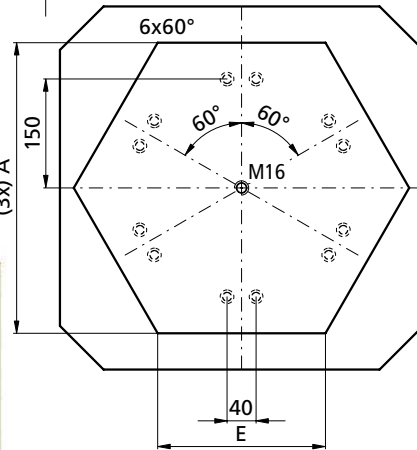
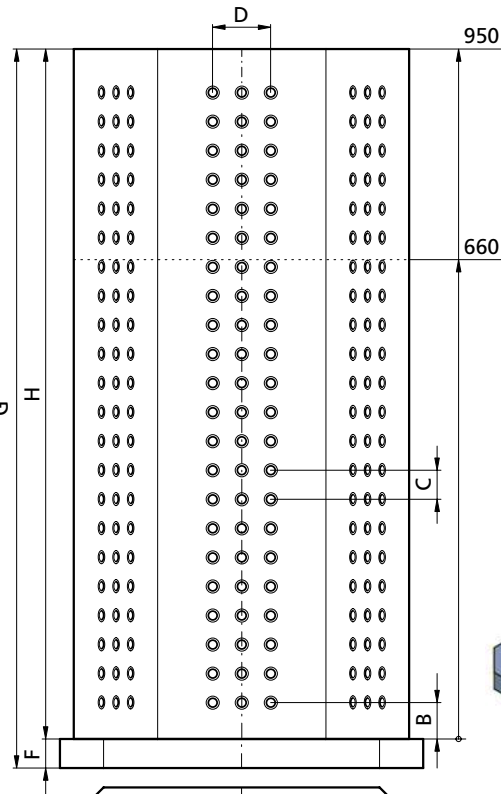

MS402395R40

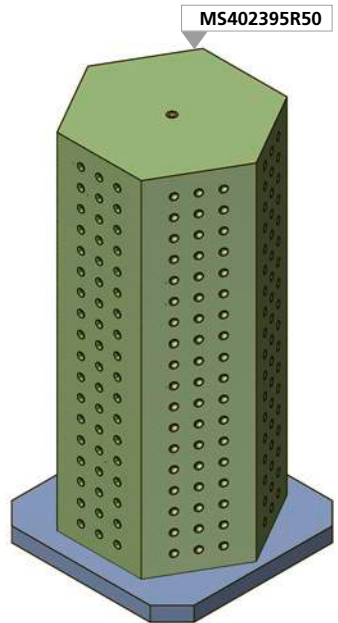

MS402395R50

Mineralgussturm mit
Stahldübel
Epoxy Mineral with
Steel Anchor

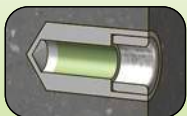

Seite / Page 250

Bestellbeispiel

Ordering example: MS321966R80 &

p. 274

Grundplatte wird passend
zu Ihrer Maschinenpalette
hergestellt und muss separat
bestellt werden!

Base plate according to your
machine configuration please
order extra!

	kg*	A	B	C	D	E	F	G	H	Raster / Grid
MS321960R50	~120	320	50	50	100	184	(40)	(640)	600	198 x M12/12F7
MS321965R50	~131	320	50	50	100	184	(40)	(690)	650	216 x M12/12F7
MS321970R50	~142	320	50	50	100	184	(40)	(740)	700	234 x M12/12F7
MS321975R50	~154	320	50	50	100	184	(40)	(790)	750	252 x M12/12F7
MS321980R50	~165	320	50	50	100	184	(40)	(840)	800	270 x M12/12F7
MS402366R40	~167	400	50	40	80	231	(40)	(700)	660	270 x M12/12F7
MS402395R40	~311	400	50	40	80	231	(40)	(990)	950	396 x M12/12F7
MS402366R50	~160	400	50	50	100	231	(40)	(700)	660	216 x M12/12F7
MS402395R50	~260	400	50	50	100	231	(40)	(990)	950	324 x M12/12F7

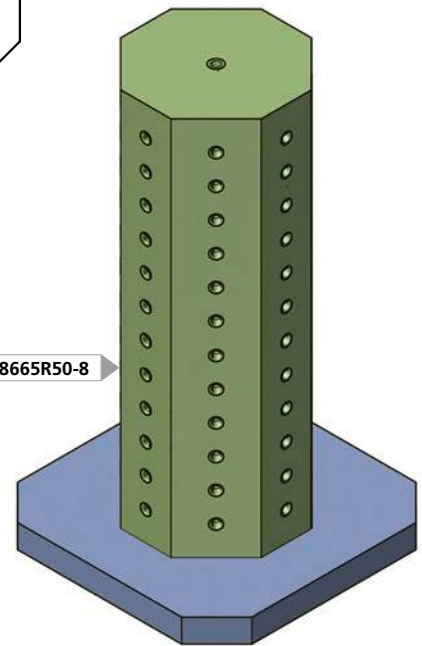
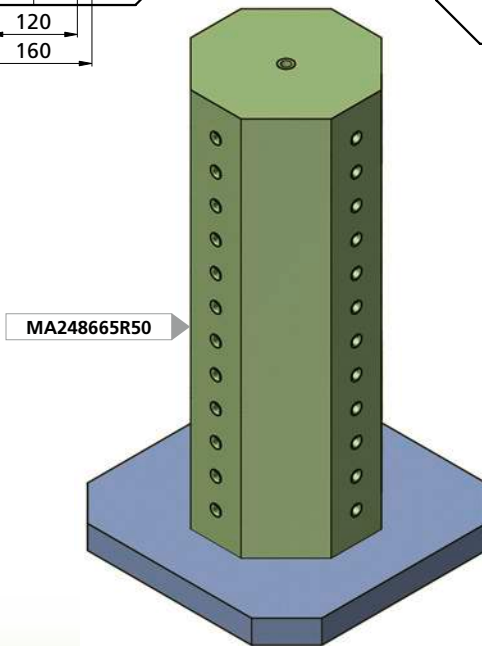
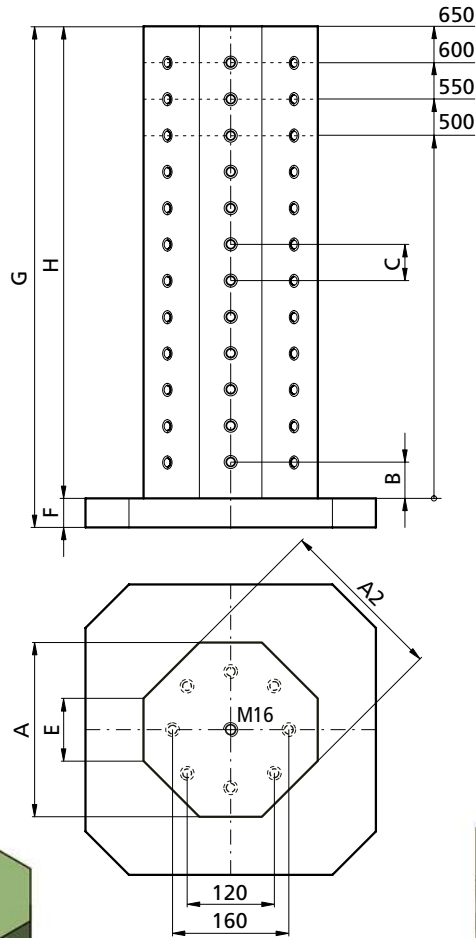
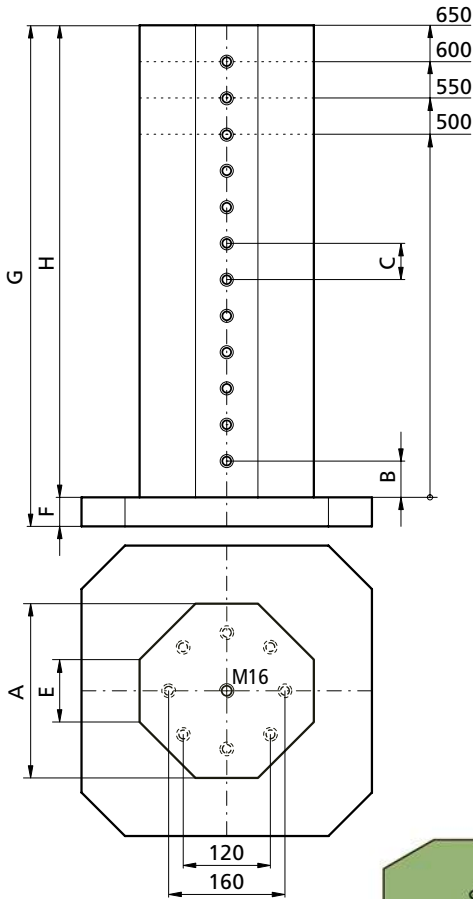

Mineralgussturm mit
Stahldübel
Epoxy Mineral with
Steel Anchor

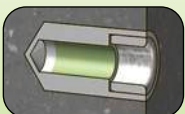

Seite / Page 250

Bestellbeispiel
Ordering example: **MR24865R50** &

p. 274

Grundplatte wird passend
zu Ihrer Maschinenpalette
hergestellt und muss separat
bestellt werden!
Base plate according to your
machine configuration please
order extra!

	kg*			A	A2	B	C		E	F	G	H	Raster / Grid
MA24865R50	~56			240		50	50		86	(40)	(540)	500	36 x M12/12F7
MA24865R50	~61			240		50	50		86	(40)	(590)	550	40 x M12/12F7
MA24866R50	~70			240		50	50		86	(40)	(640)	600	44 x M12/12F7
MA24866R50	~72			240		50	50		86	(40)	(690)	650	48 x M12/12F7
MA24865R50-8	~61			240	230	50	50		86	(40)	(540)	500	72 x M12/12F7
MA24865R50-8	~67			240	230	50	50		86	(40)	(590)	550	80 x M12/12F7
MA24866R50-8	~71			240	230	50	50		86	(40)	(640)	600	88 x M12/12F7
MA24866R50-8	~79			240	230	50	50		86	(40)	(690)	650	96 x M12/12F7

* Gewicht ohne Grundplatte! / Weight without baseplate!

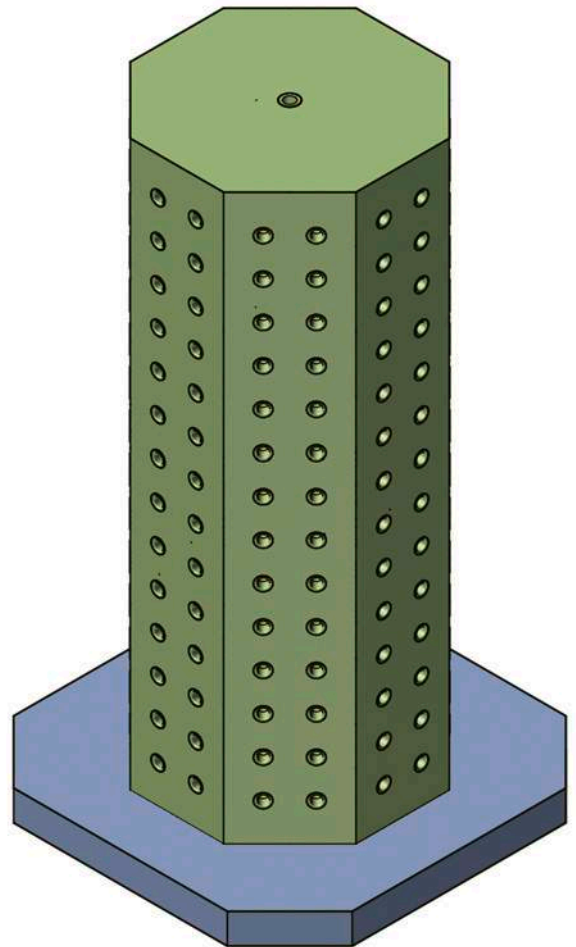
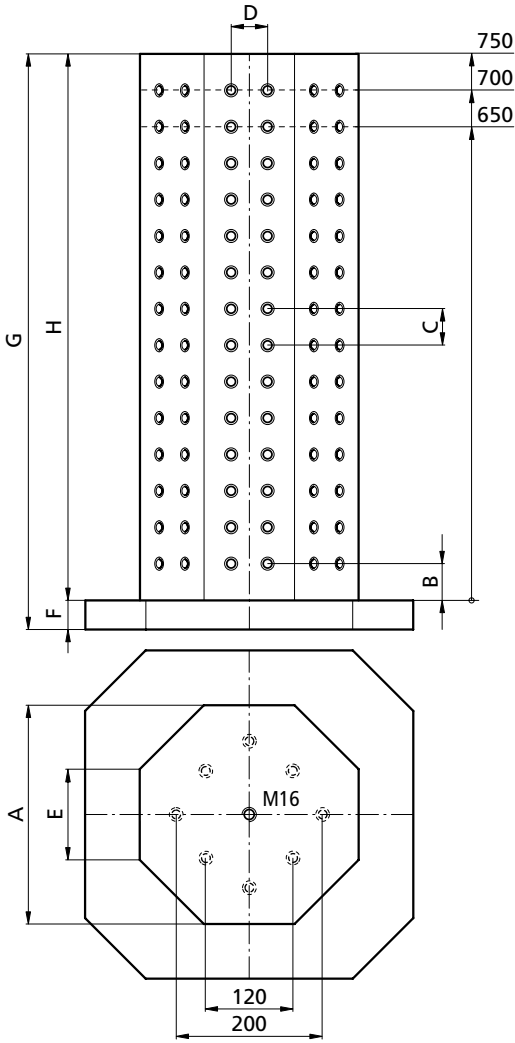

Grundplatte wird passend zu Ihrer Maschinenpalette hergestellt und muss separat bestellt werden!
Base plate according to your machine configuration please order extra!

Mineralgussturm mit
Stahldübel
Epoxy Mineral with
Steel Anchor

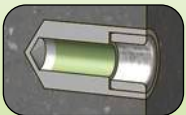

andere Höhen auf Anfrage
other heights on request

Seite / Page 250

Bestellbeispiel
Ordering example: MA301265R50-8-2 & _____ p. 274

	kg*	A	B	C	D	E	F	G	H	Raster / Grid
MA301265R50-8-2	~118	300	50	50	50	125	(40)	(690)	650	192 x M12/12F7
MA301270R50-8-2	~130	300	50	50	50	125	(40)	(740)	700	208 x M12/12F7
MA301275R50-8-2	~156	300	50	50	50	125	(40)	(790)	750	224 x M12/12F7

* Gewicht ohne Grundplatte! / Weight without baseplate!

Minergusserhöhung für 5-Achsenmaschinen

Epoxy casting raises blocks for 5-axis machines

tripoxyMINERAL

Art. Nr.	kg	H	Raster / Grid R50
MUB2817-H85	~8,7	85	9 x M12/12F7
MUB2817-H100	~10,3	100	
MUB2817-H125	~12,9	125	

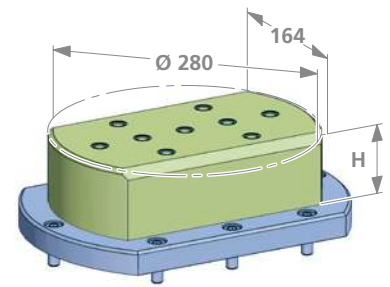

Minergusserhöhungen um eine optimale Bearbeitungshöhe und Zugänglichkeit mit der Spindel zu erreichen.

Epoxy casting raises to achieve an optimal machining height and accessibility with the spindle.

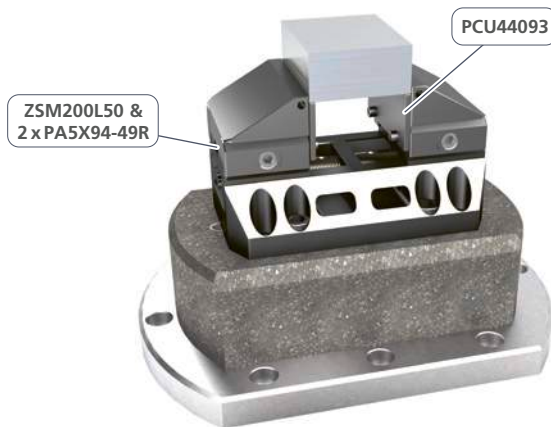

Art. Nr.	kg	Raster / Grid R50
MUB3535H140	~44,1	73 x M12/12F7



Diese Minergusserhöhung mit schrägen Basisschienen (PCB50207W27) und einer seitlichen Anordnung weiterer Spannstellen, bietet Ihnen eine Vielzahl an Spannmöglichkeiten.

This mineral casting raises with inclined base rails (PCB50207W27) and a lateral arrangement of further clamping points offers you a wide range of clamping possibilities.

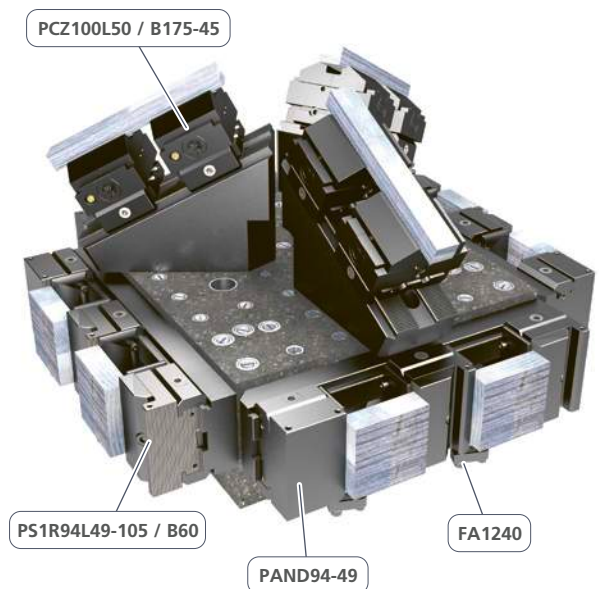
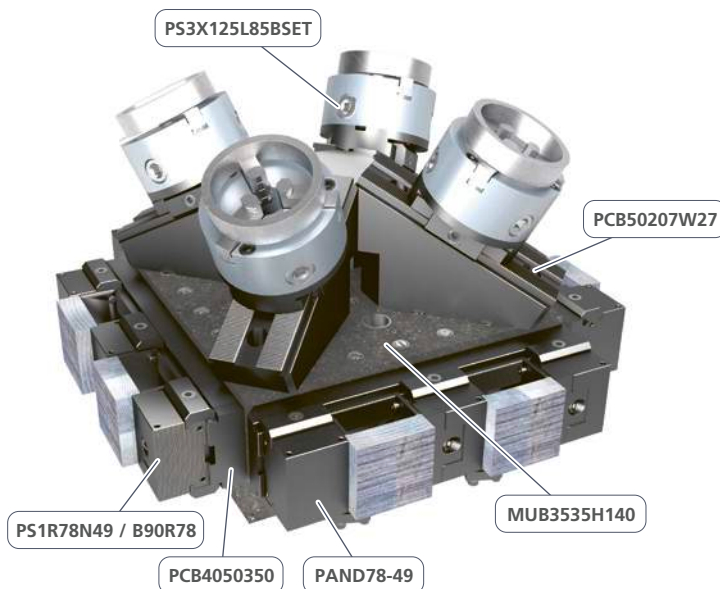
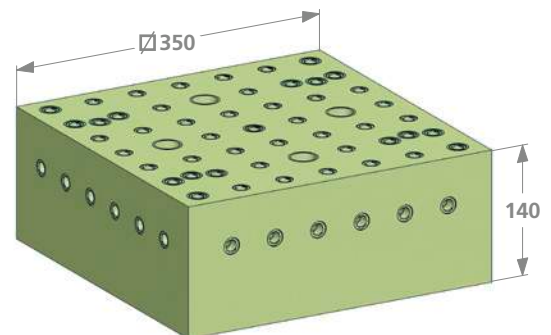

SMK24-24-42 OPP200

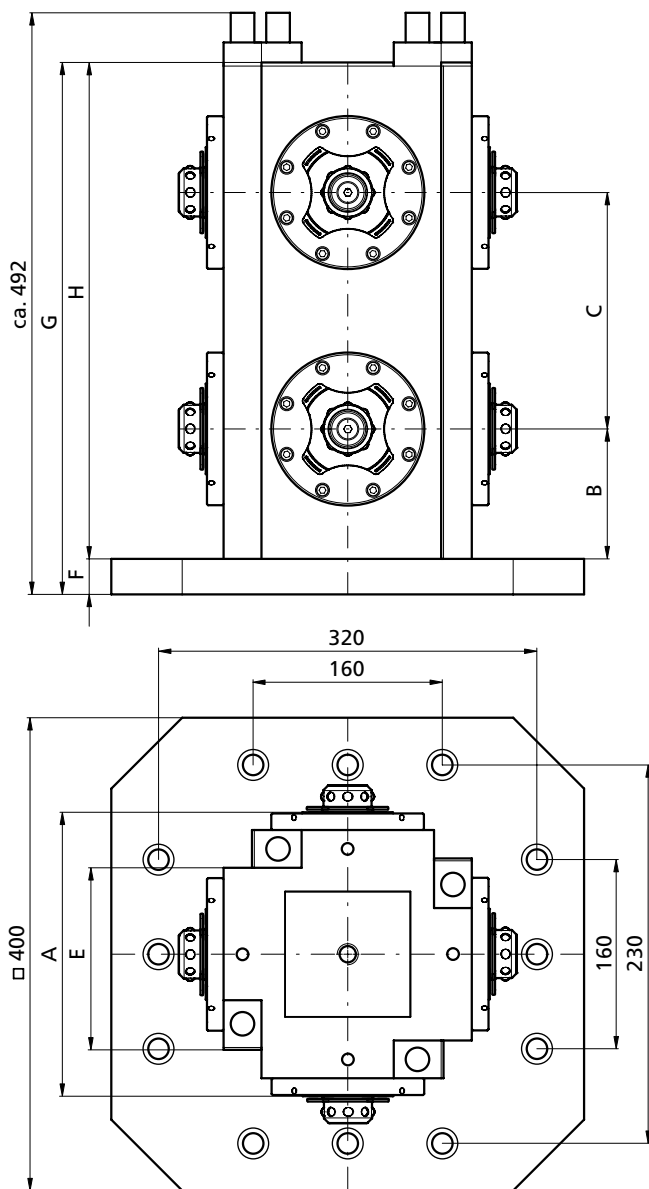

SMK30-17-42 OPP200

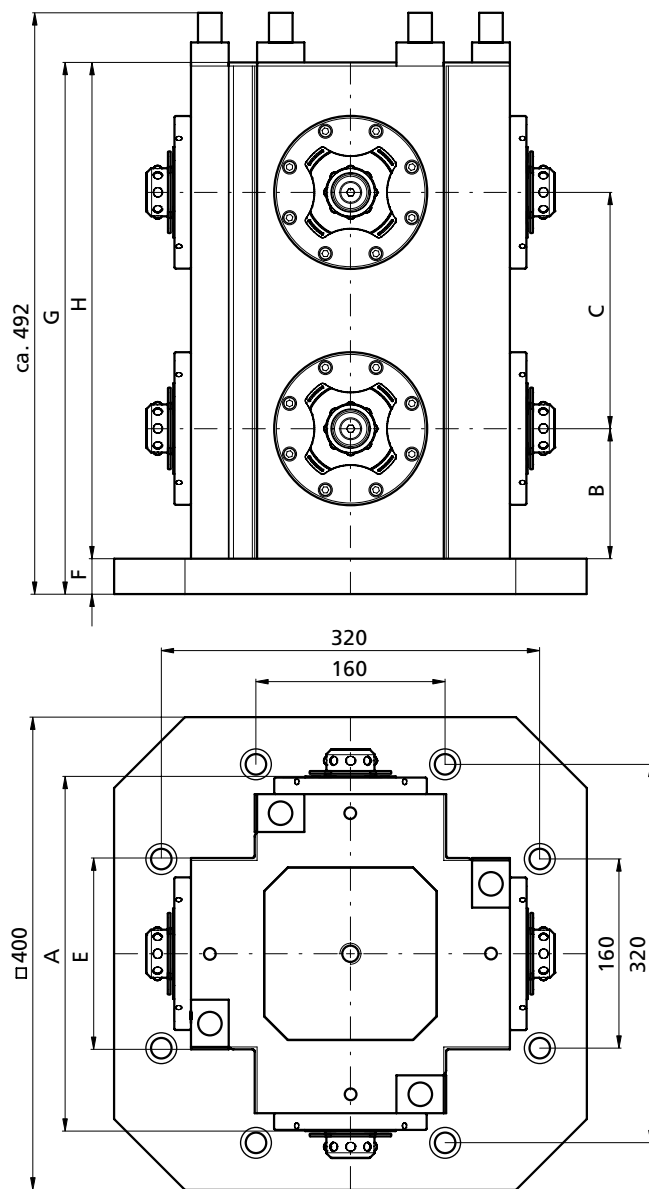

Stahl-Mineralguss

Steel-epoxy mineral tombstones

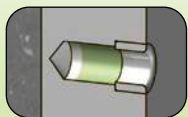

andere Höhen auf Anfrage
other heights on request

Seite / Page 250

Bestellbeispiel
Ordering example: **SMK242442OPP-200**

	kg	A	B	C	E	F	G	H	Raster / Grid
SMK24-24-42OPP200	~120	240	110	200	166	(30)	(450)	420	OPP-200
SMK30-17-42OPP200	~142	300	110	200	166	(30)	(450)	420	OPP-200

Stahl-Mineralgusstürme
Steel-epoxy mineral tombstones

tripoxyMINERAL

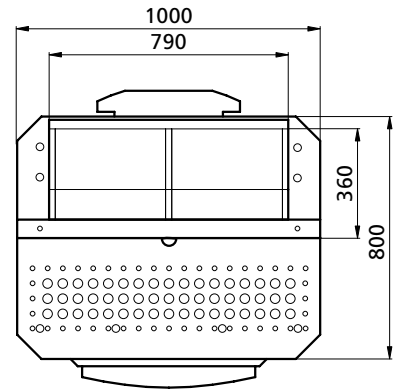
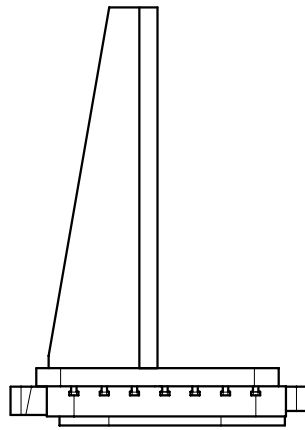
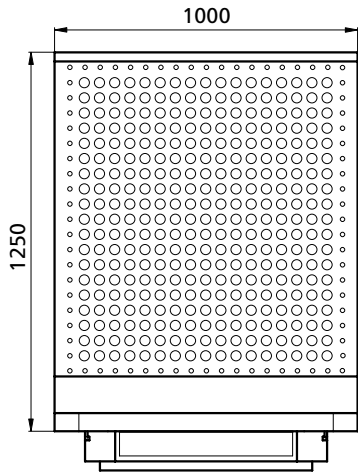

Gesamtgewicht
 Total weight **~1300kg**



Epoxy

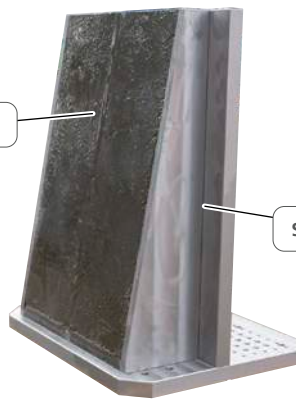

Stahl / Steel



SPECIALS

Patent pending



Beine aus rostfreiem Stahl oder Holz
 Legs made of stainless steel or wood

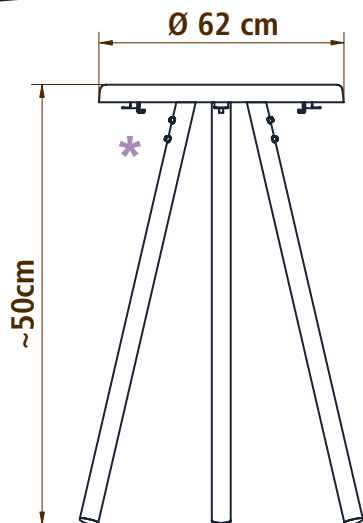

* Inkl. 3x Flaschenöffner / Kleiderhaken
 Incl. 3x bottle opener / coat hook



Ihr Logo hier
 Your logo here



Salontisch
Salon table

Jeder Tisch ist ein Unikat
 - Hergestellt aus Schweizer Stein-Granulat

Each table is unique
 - Made from Swiss stone granulate

Art. Nr.

MST-TRI-600

Grundplatten für Mineralgusstürme
Base plate for epoxy mineral tombstone

	A	B	C	kg
GPL30040	300	300	40	~27
GPL40040	400	400	40	~47
GPL50040	500	500	40	~74
GPL45040	450	450	40	~61
GPL50040040	500	400	40	~58
GPL63040	630	630	40	~120
GPL80040	800	800	40	~195

Rasterplatten für 5AX-Master
Grid plate for 5AX-Master

	A	B	C	Raster / Grid	kg
RPQ50504-R50	500	500	40	M12/12F7	~74
RPD504-R50	∅ 500		40	M12/12F7	~64

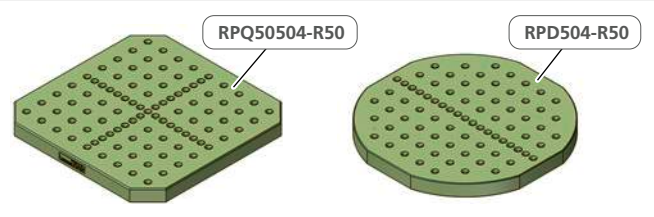

Andere Grössen auf Anfrage
Other dimensions available on request

Im Lieferumfang: Schrauben zur Befestigung des Turms, ohne Positionierzapfen und Schrauben maschinenseitig.
The package: Screws for fixing the tombstone, without screws and counter piece to the machine side.

Bohrungen der Grundplatte / Drill holes in the baseplate:
Kundenspezifisch an die Maschine angepasst
Made up to customer's specifications

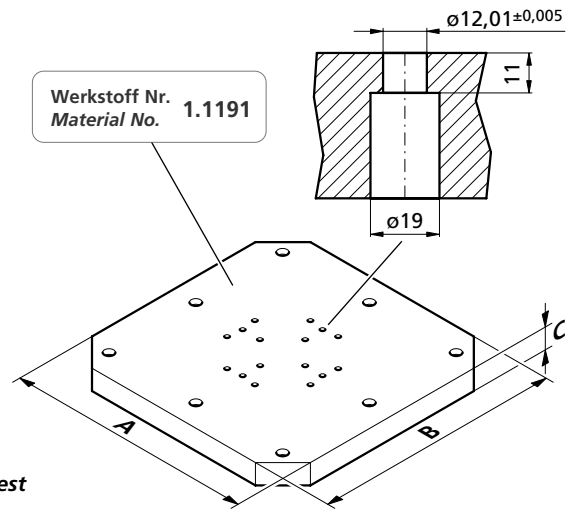

GPL40040-UV

kg ~40,34

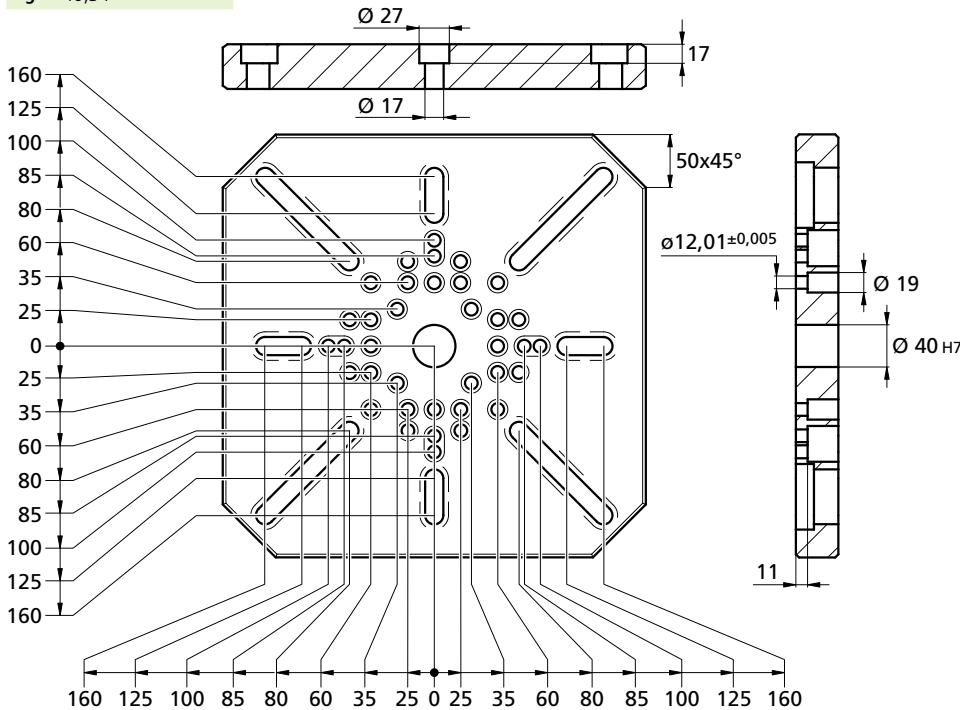

27 verschiedene Mineralgusstürme passend zu dieser Grundplatte.
27 different Epoxy mineral tombstone are suitable for this base plate.

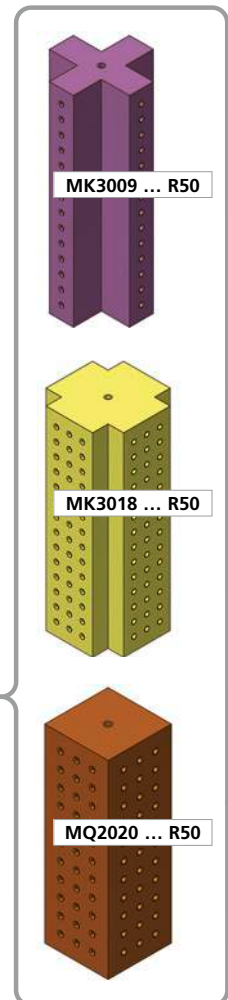

MABD501550

MABD502050

MABD502550 MABD503050

tripoxyMINERAL

Abdeckbleche zum Schutz der Oberfläche der Mineralgusstürme
Cover plates for surface protection of epoxy mineral tombstones

MABD501550

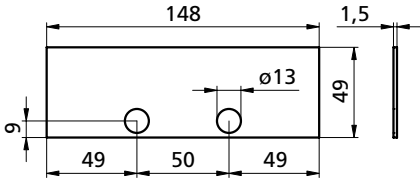

MABD502050

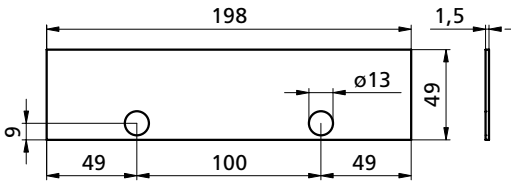

MABD502550



MABD503050

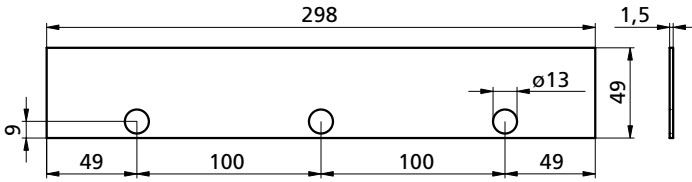

M12X25DIN7984

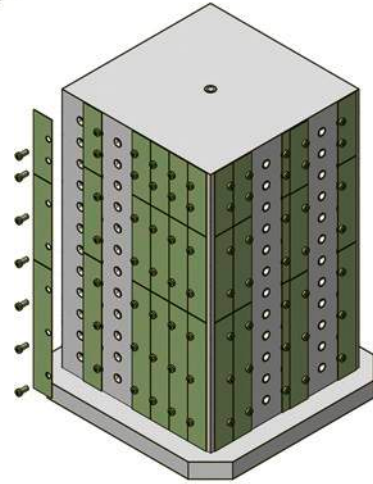
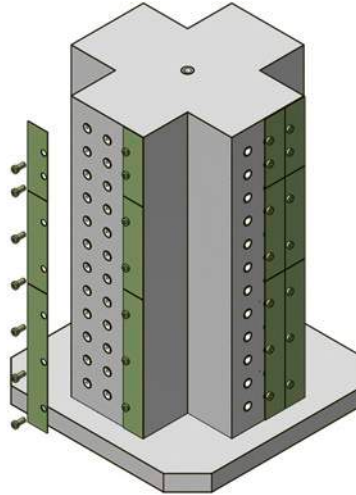
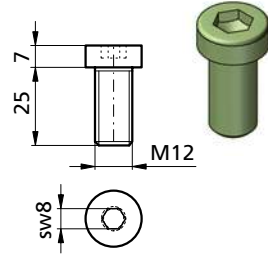

Stahl-Mineralguss
Steel-epoxy mineral tombstones

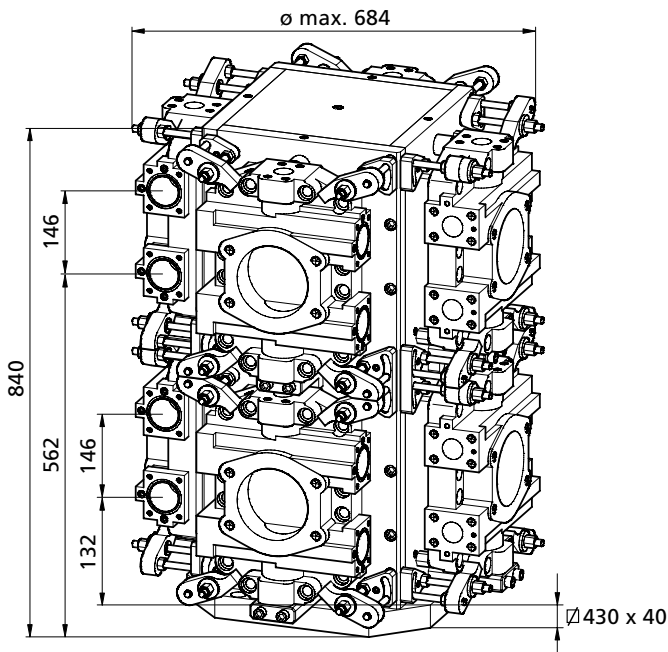

Gesamtgewicht
Total weight
~600kg

~38 kg

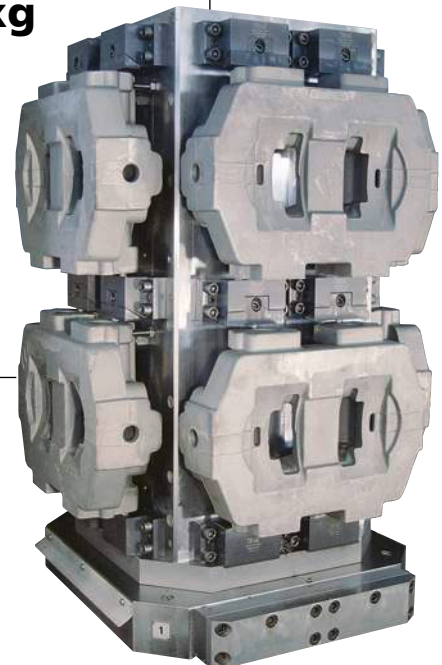

Stahl Mineralgusserhöhungen

Steel-epoxy raises blocks

SMUB2373H220

SMUB3373H220

tripoxyMINERAL

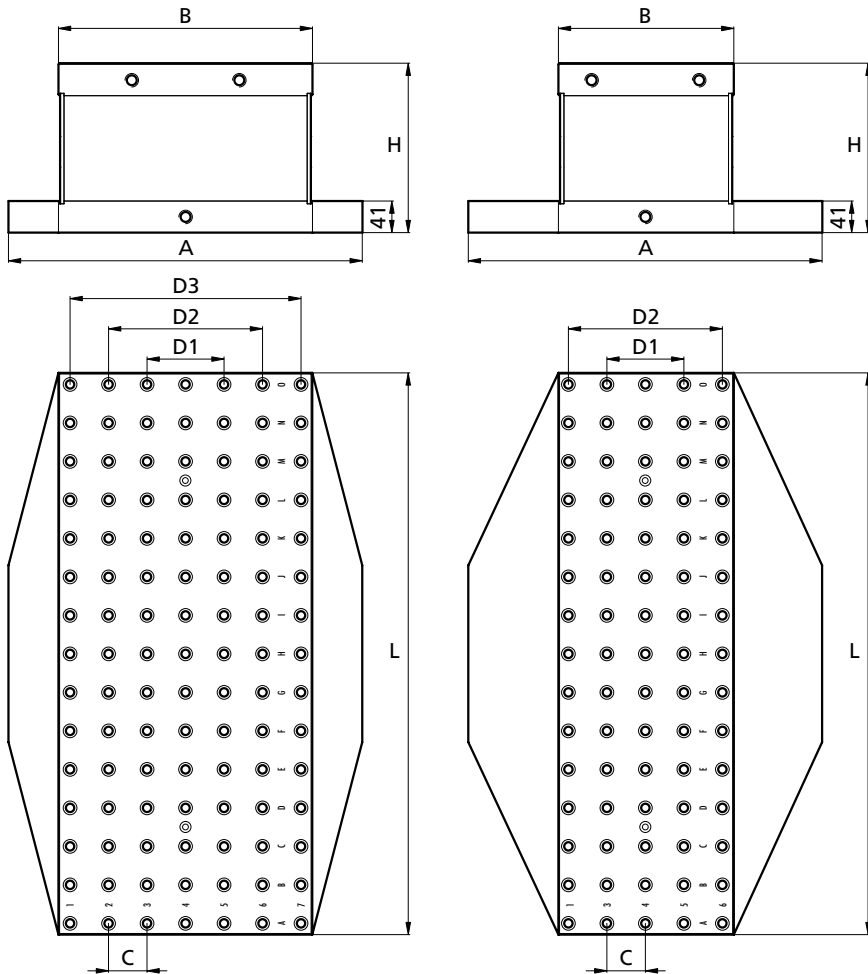

**Entwickelt für die Luftfahrt.
Gewappnet für höchste Anforderungen.**

Sehr hohe Vibrationsdämpfung dank Kern aus Mineralguss. Hohe Festigkeit dank Ummantelung aus Stahl. Begünstigt die Gewichtsreduktion wodurch die Maschine geschont wird.

Mit integrierten Vakuum Kanälen erhältlich.

**Developed for aviation.
Prepared for the highest requirements**

Very high vibration damping thanks to mineral cast core. High strength thanks to the coat made of steel. Supports weight reduction which protects the machine.

Raisers can be made with integrated vacuum channels.

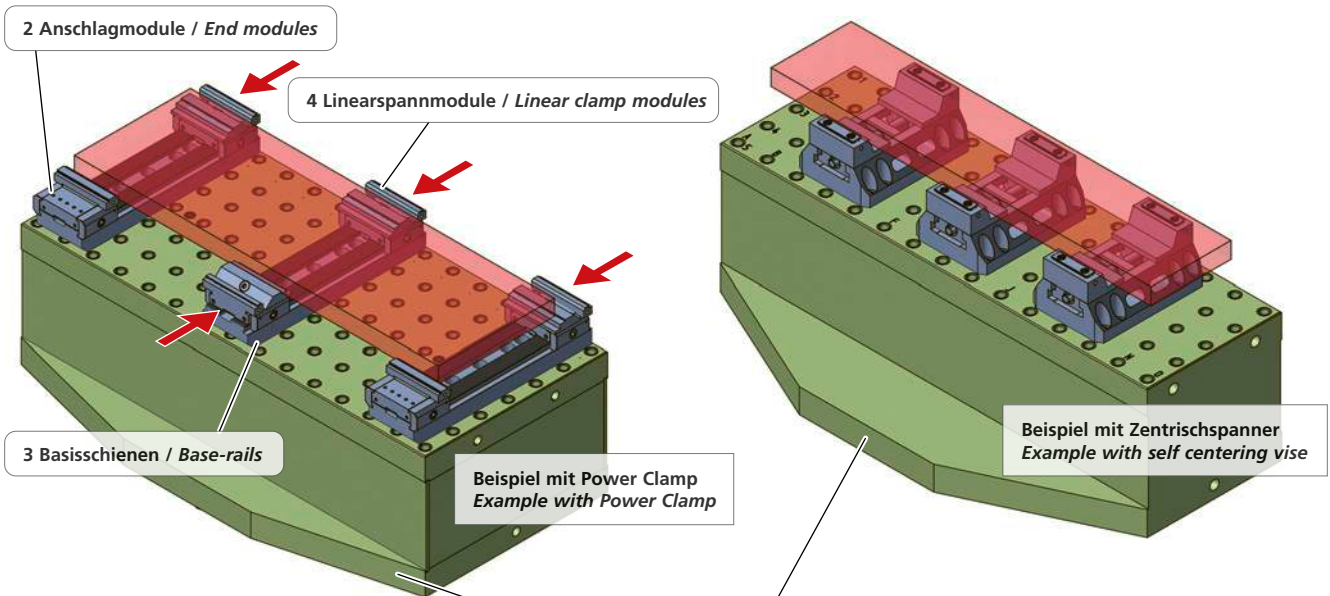

Stahl-Mineralguss
Steel-epoxy mineral tombstones

kg

Bestellbeispiel
Ordering example: **SMUB2373H220**

		A	B	C	D1	D2	D3	H	L	Raster / Grid
SMUB2373H220	~168,0	460	230	50	100	200		220	730	75 x M12/12F7
SMUB3373H220	~214,4	460	330	50	100	200	300	220	730	105 x M12/12F7

Separat bestellen / Order separately

Stahl Mineralgusserhöhungen mit integriertem Vakuum Anschluss

Steel-epoxy raises block with integrated vacuum

tripoxyMINERAL

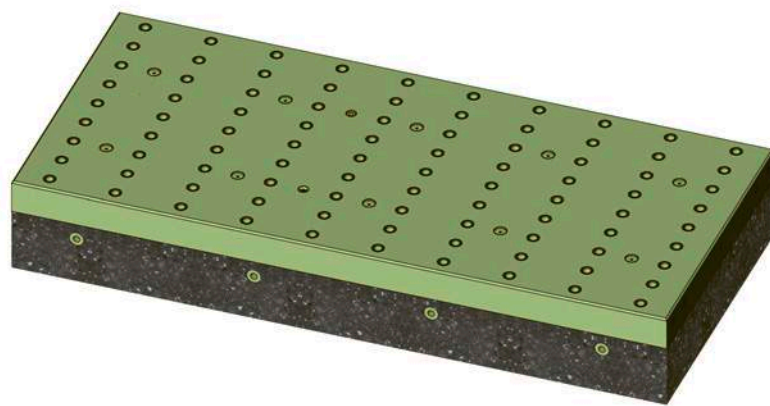
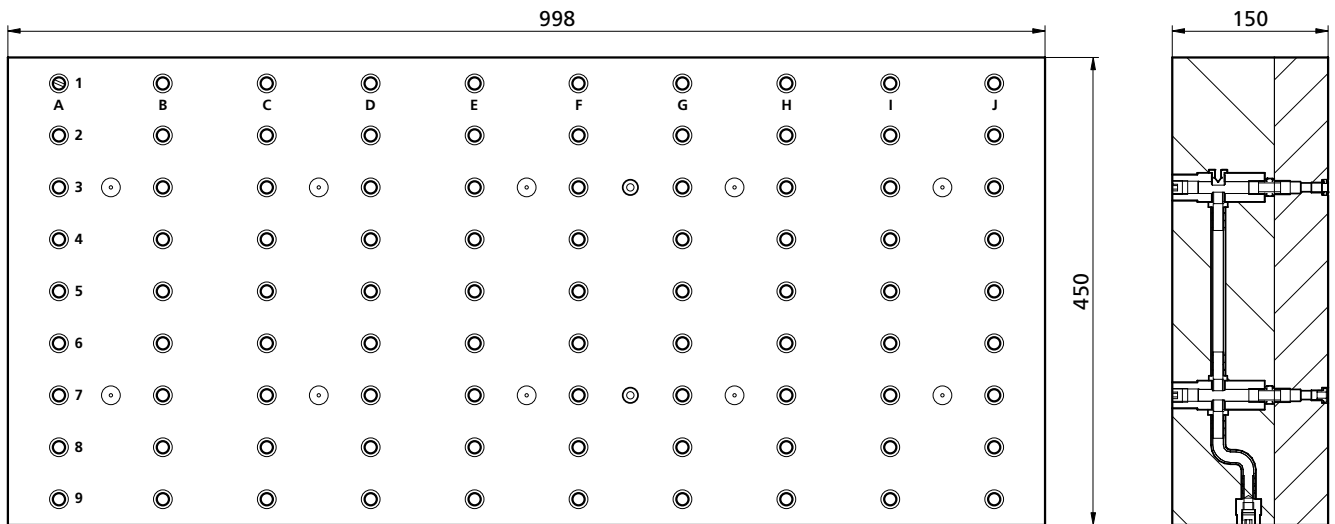

Balken und Würfel aus Stahl-Mineralguss
Trunion and cubes made from steel epoxy

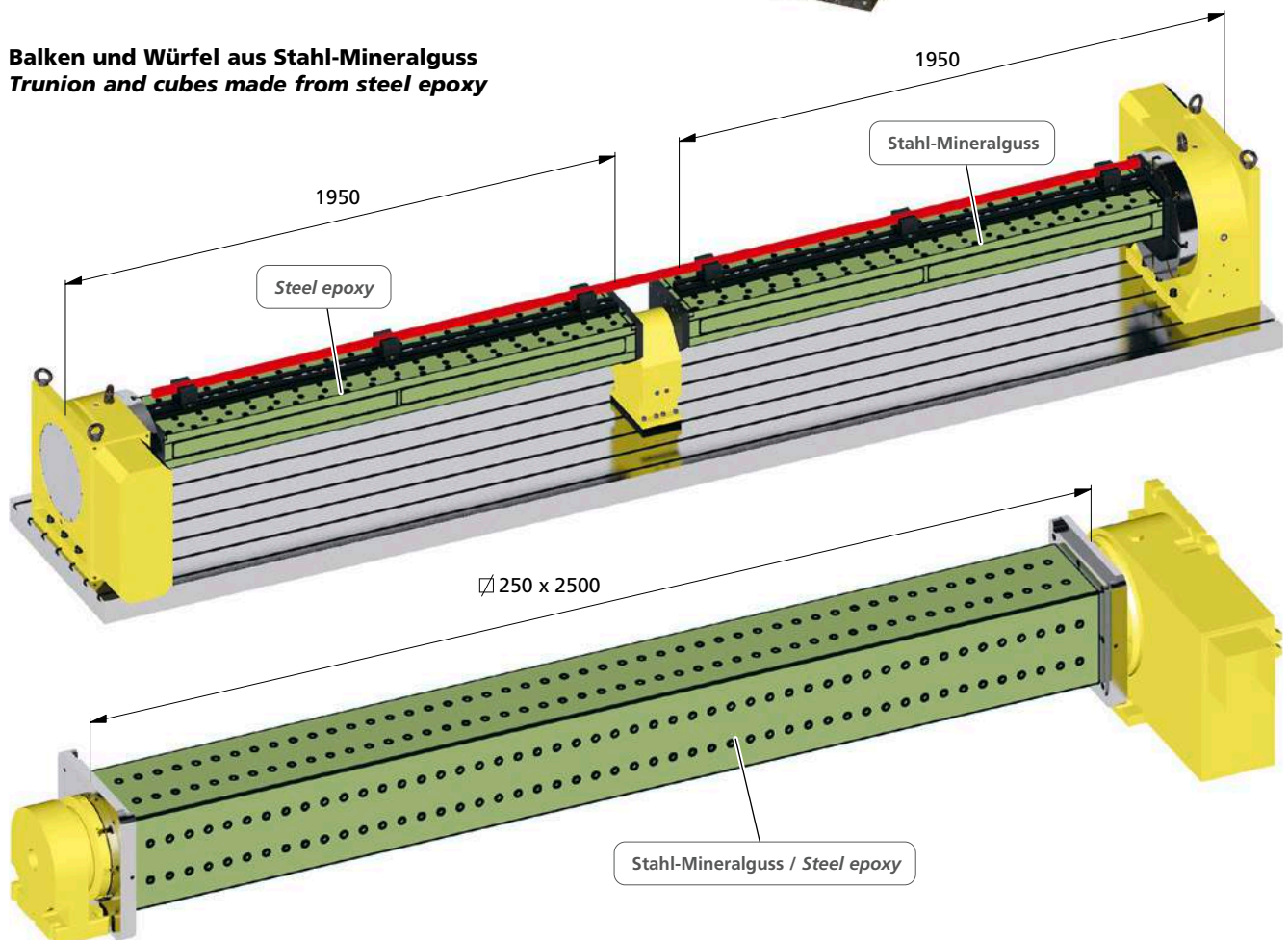

Mineralgusstürme seit
Epoxy tombstones since

1998

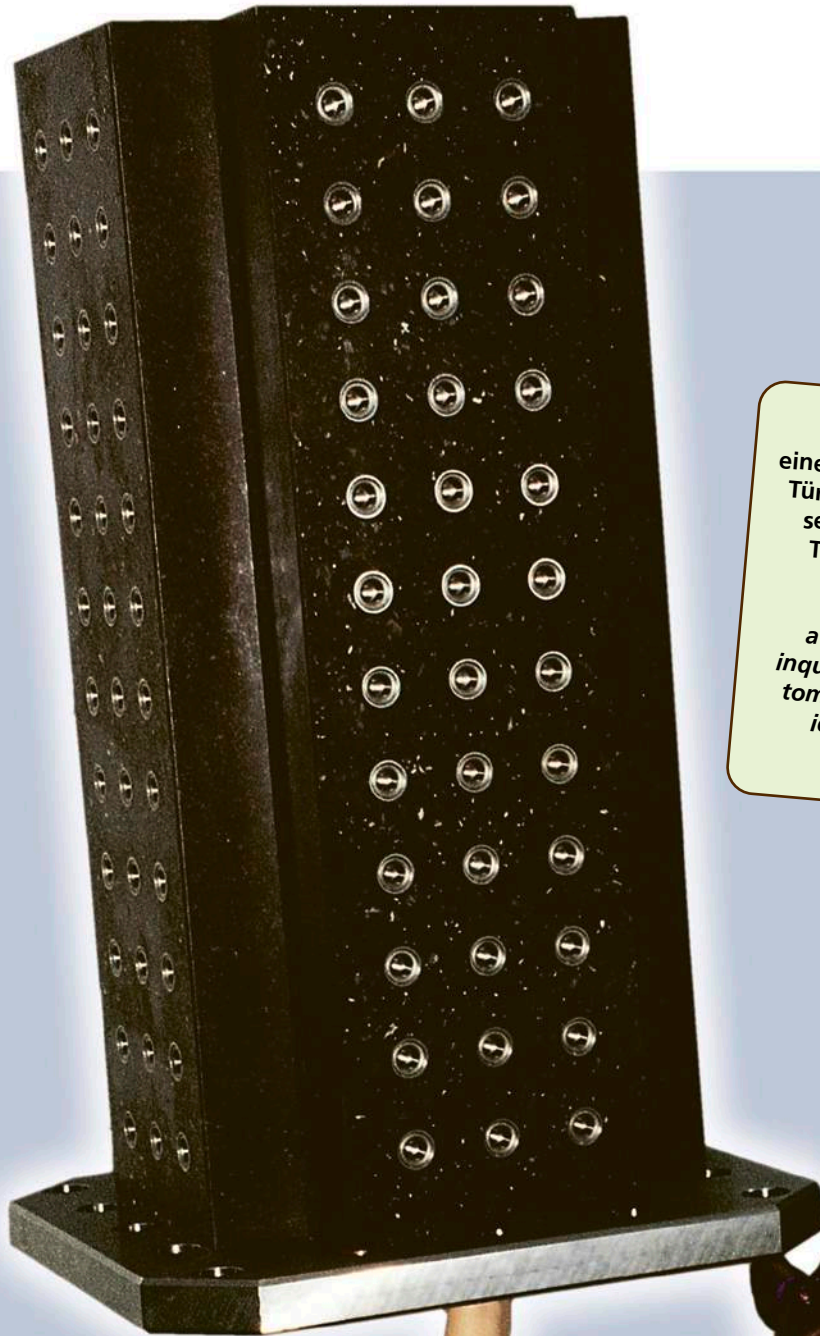

Beat Baumgartner erhält von einem Kunden eine Anfrage für leichte Türme, die aber nicht aus Aluminium sein dürfen. Er hat die Idee, einen Turm aus Mineralguss zu bauen.

Beat Baumgartner receives a request from a customer who inquires about light, non-aluminium tombstones. He comes up with the idea to build a mineral epoxy tombstone.



oppSYSTEM & 5axes

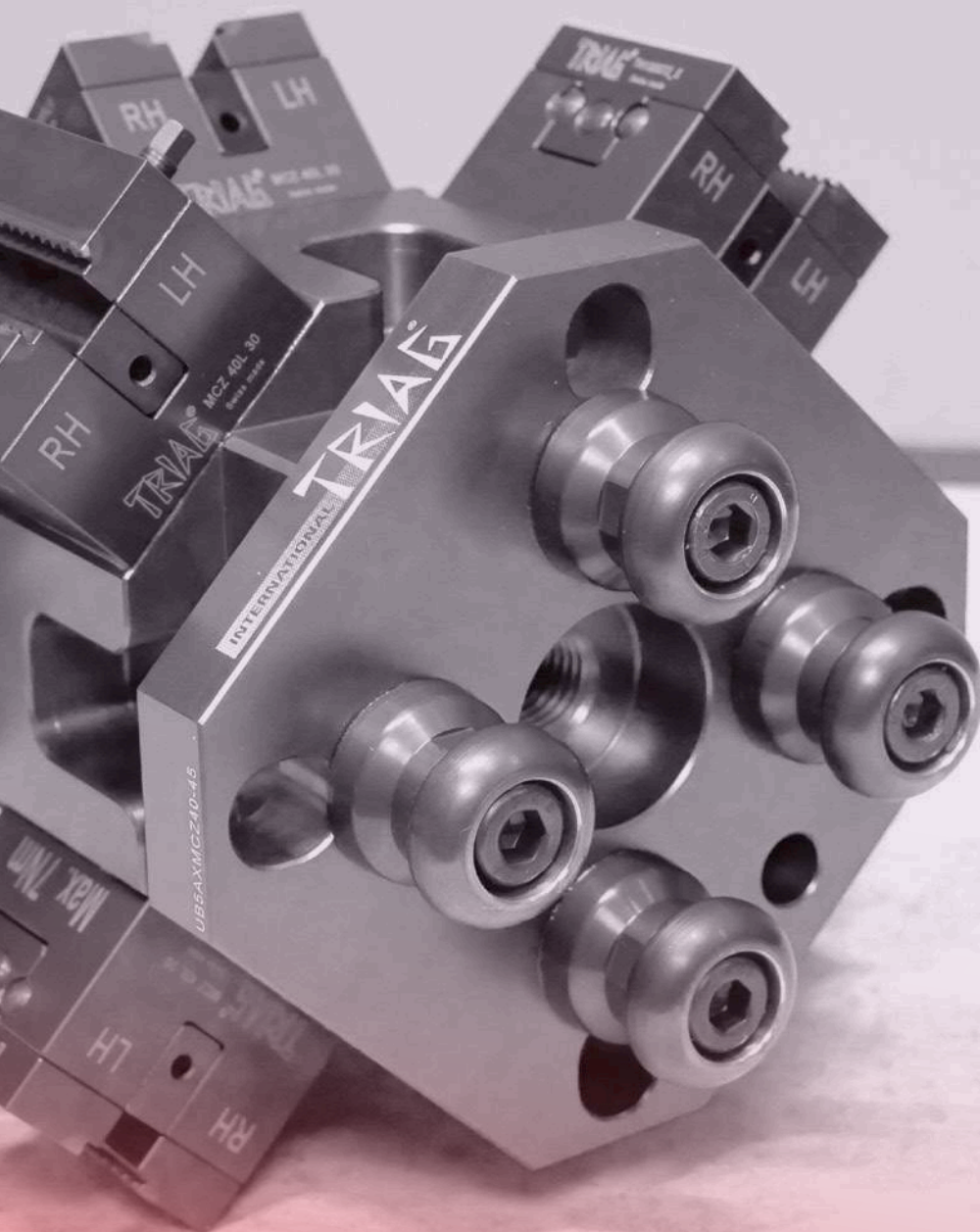



Einleitung | *Introduction* 281 - 283

Anwendungsbeispiele | *Examples of application* 284 - 285

Mechanisches Nullpunktsystem mit diversen Spannlösungen
Mechanical zero point system with different workholding solutions 286

0-Punkt Schnellwechselsystem | *Mechanical zero point system* 287



4-Achs Lösungen für mechanische 0-Punkt Schnellwechselsysteme
4-axis solution for mechanical 0-point quick change systems 288



0-Punkt Erhöhung & Ausrichtplatte
Zero point riser & Alignment plate 289

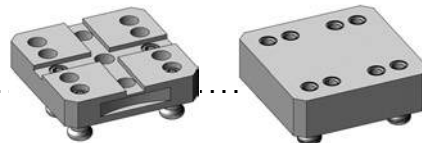

Dreibackenfutter | *Three-jaw chuck* 290

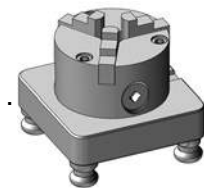

Klemmbüchse | *Clamping-case* 291



Zentriereinheit | *Chuck unit* 292

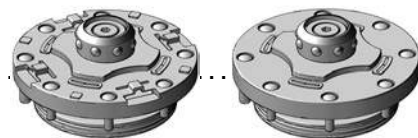

Palettenträger | *Receiver chuck with chucks* 293

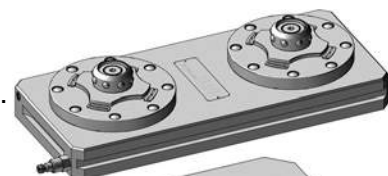

MTS Palettier-System | *MTS palleting system* 297 - 300

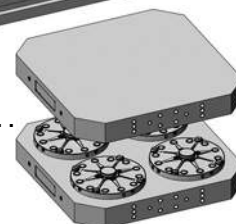

Zubehör | *Accessoires* 301



Nullpunkt-Palettiersystem

Zero-point palleting system

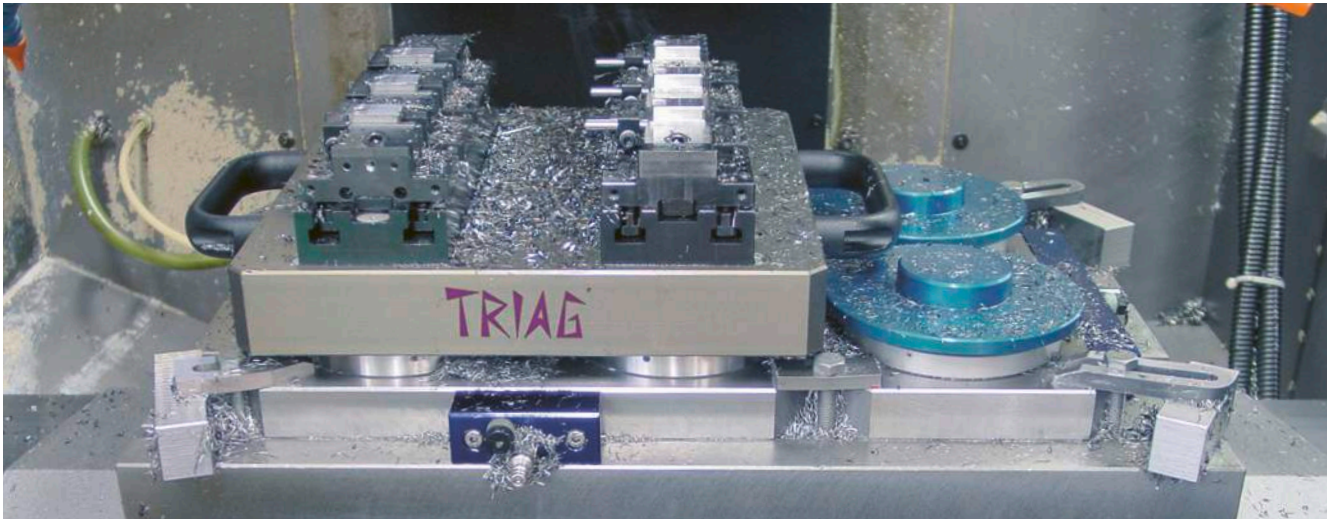

In den letzten Jahren wurden die Werkzeugmaschinen viel leistungsfähiger. Damit wurden die Bearbeitungszeiten wesentlich kürzer. Aufgrund der vom Auftraggeber verlangten Lieferzeiten „just in time“ sind aber die Losgrößen geringer geworden, was zu vermehrten Einrichtzeiten führt.

The productivity of modern machining centers has been drastically increased over the past years. Hence the time per workpiece is falling. On the contrary the batch sizes are getting smaller due to the increasing trend to „just in time“ production.

Auch die technisch hochentwickelten Maschinen sind jedoch immer noch mit einem T-Nuten Tisch ausgerüstet. Die Befestigung und das Ausrichten des zu bearbeitenden Werkstückes auf dem T-Nutentisch kann nur während der (teuren) Maschinen-Stillstandszeit erledigt werden. Diese Unproduktivität kumuliert sich, wenn die Werkstückbearbeitung mehrere Maschinenprozesse und somit mehrmaliges Befestigen und Ausrichten erfordert.

This means that the machine must be set up more frequently. Is the machine not equipped with a pallet changer, the set up and the changing of workpieces may only be accomplished during the stand still of the machine. This idling of the machine results in the loss of costly productive machine time. As it is, the aim of any machining facility to keep the spindle turning, the unproductive time must be minimized. As any machinist knows, the set up and alignment of workpieces on a T-slot table is very awkward and time consuming.

Die Lösung, die wir Ihnen für dieses Problem bieten, ist unser neuartiges, modulares Palettiersystem, das oppSystem.

The TRIAG opp (Zero-Point-Palleting) System represents an ideal interface between machining table and workholding device.

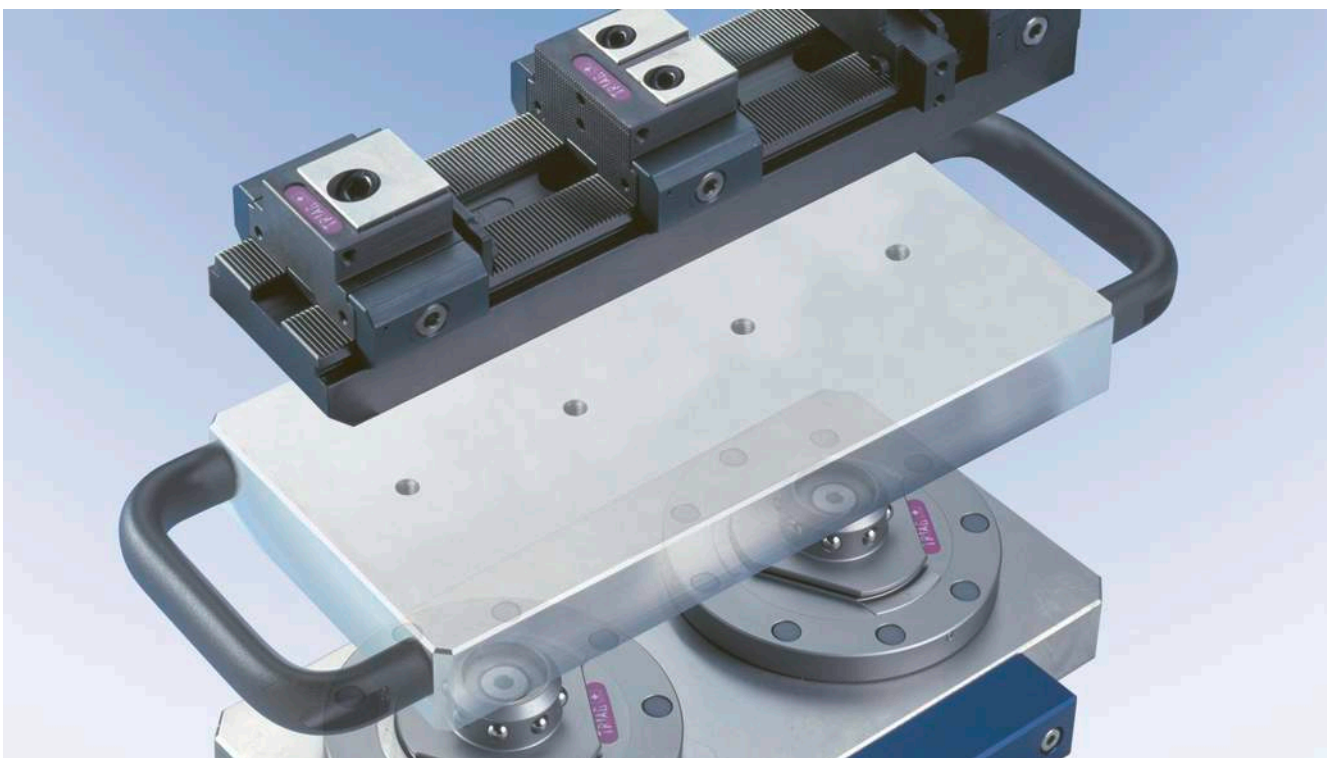

Das System besteht aus dem auf dem Maschinentisch der Werkzeugmaschine montierten Palettenträger und mindestens zwei Paletten oder mit Zentrier- und Klemmbüchsen ausgerüsteten Werkstückträgern. Die sehr präzise gefertigte Schnittstelle zwischen dem Palettenträger und der Palette ermöglicht ein sekundenschnelles Ein- und Auswechseln der Paletten, auf welcher ausserhalb der Werkzeugmaschine das zu bearbeitende Werkstück montiert und positioniert wird. Es wird eine sehr hohe Ausnutzung der theoretisch zur Verfügung stehenden Maschinenlaufzeit erreicht. Dies erhöht die Produktivität der Maschine und damit die Wirtschaftlichkeit des ganzen Betriebes.

Im Gegensatz zu vielen anderen Palettiersystemen auf dem Markt ist die Dimension des oppSystems in Form von Stichmassen genormt und richtet sich damit nach den individuellen Werkstückdimensionen. Die patentierte Konstruktion erlaubt überdies auch die unbemannte Be- und Entladung mit Hilfe eines Beschickungsgerätes.

Mit dem oppSystem sind 750'000 Spannungen ohne Referenzverlust möglich, bei einer Repetiergenauigkeit von $\pm 0,002$ mm. Das Lösen erfolgt pneumatisch mit ca. 6 bar, womit keine Mehrkosten für Hydraulikaggregate entstehen. Eine allfällig entstehende Wärmeausdehnung wird über die federnde Zentrierung kompensiert. Alle wichtigen Bauteile sind wartungsarm, leicht zu überprüfen und im Bedarfsfall einfach auszutauschen.

On the machine table the receiver chuck is installed. This chuck may consist of one, two, four, six or more receiver units. Onto these air operated receiver chucks a pallet, a fixture or a vice is mounted within a matter of seconds. On the bottom surface of the workholding devices centering rings are inserted. These centering rings are ground to a very high accuracy permitting the locking down of the workholding device with a repeatability of ± 0.002 mm on all three axes. The chucks are locked by spring force and unlocked by compressed air of 6 bar. This means that no hose connection is necessary during machining. Hydraulic pumps or hydraulic amplifiers are superfluous.

The patented oppSystem allows for 750'000 locking and unlocking cycles without loss of positioning accuracy. If necessary, the changing of the pallet may be accomplished by a robot or a handling system. Thermal expansion is compensated for by the spring loaded centering units.

Due to the unique oppSystem it is possible to bring the loading and unloading of the actual workpiece out of the machine which guarantees a maximum of productive machine time. Maintenance is simple as all components are easily accessible and replaceable. There are standard receiver chucks and pallets available with two or four receiver units. For other solutions or dedicated fixture you should contact TRIAG or your nearest dealer.

SMK30-17-42 OPP200 ~ 142 kg

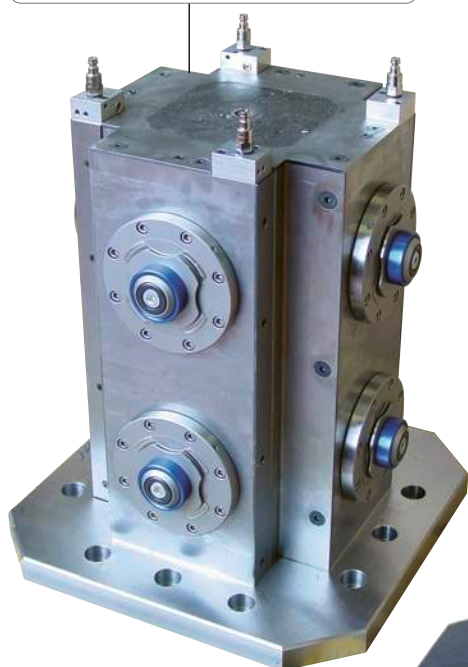

SMK24-24-42 OPP200 ~ 120 kg

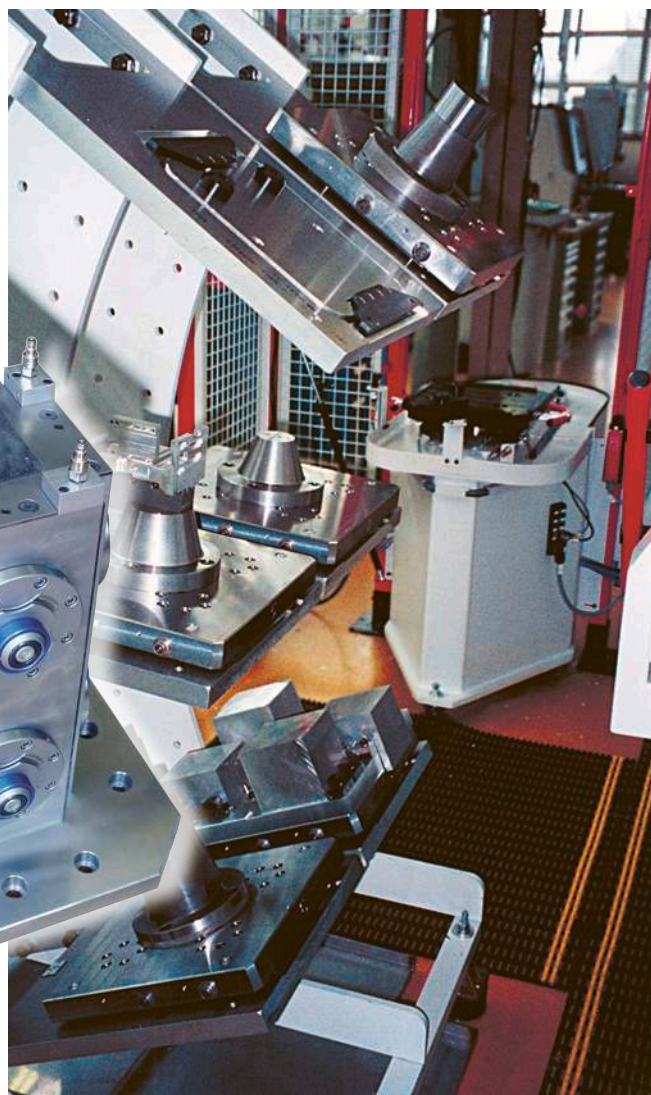
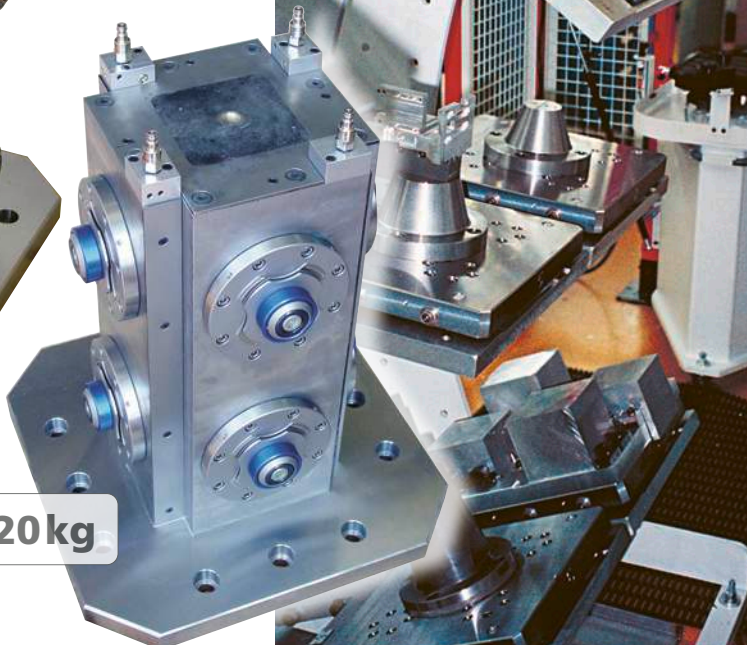

Mehr Informationen siehe Tripoxy Mineral
For more information check the Tripoxy Mineral

p. 272

Nullpunkt-System OPP & Erowa MTS

In Verbindung mit dem Spannsystem powerCLAMP bilden die Nullpunkt-Paletten oppSysteme sehr kompakte, hochgenaue und schnell wechselbare Spannvorrichtungseinheiten.

Zentrischspanner mit OPP-Anschluss

Das neue mechanische 0-Punktsystem (**OPBM4Q100R50**) findet seine Einsatzmöglichkeiten in allen Bereichen.

Von der einfachen Schnellwechselpalette zur Einzelteilmontage bis hin zur Mehrfachspannung in modernen Fräszentren.

Dank der hohen Wiederholgenauigkeit lassen sich Grossserien problemlos und in höchster Genauigkeit fertigen.

Zero-point system OPP & Erowa MTS

Together the modular system with zero point pallets, give a great performance! Fast changing and accurate!

Self centering vise with integrated zero point adaptation OPP

Because of its compact build body this self centering vise gives a perfect performance to automated 5 axis machines!

The index zero point system is built into the body of the vise, a sub pallet as you normally mount the vises!

The OPP system is a very accurate system reliable and durable! We guarantee 150'000 changes within $\pm 0,002\text{mm}$

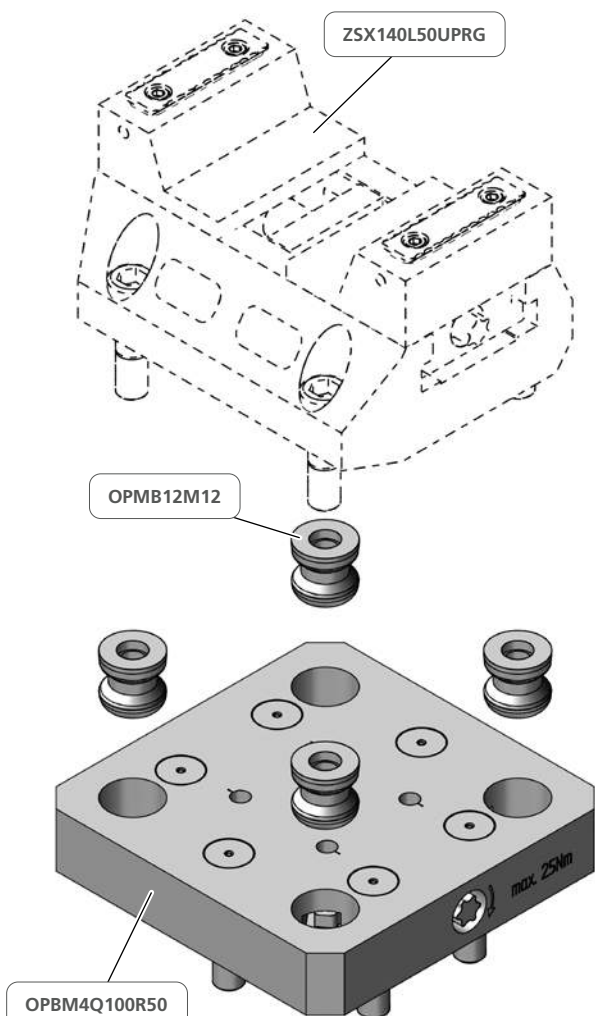

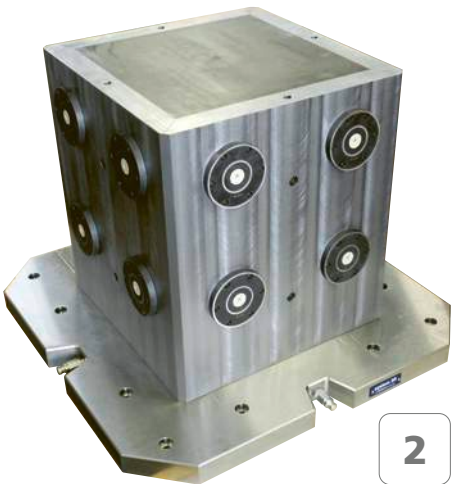

HORIZONTAL

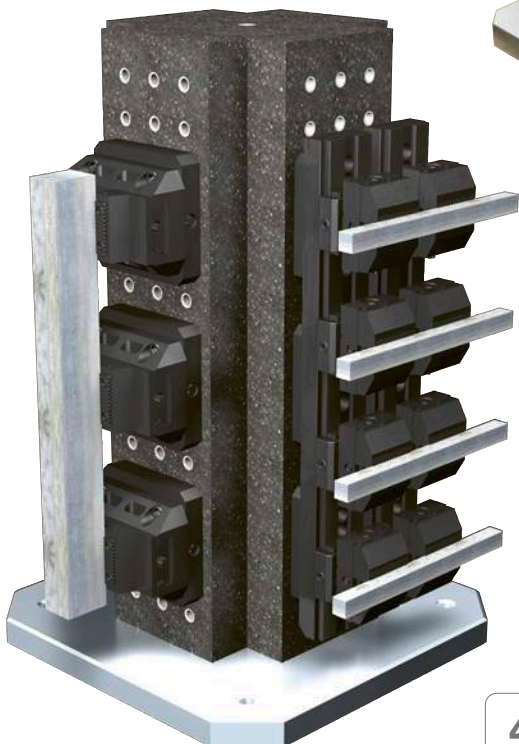

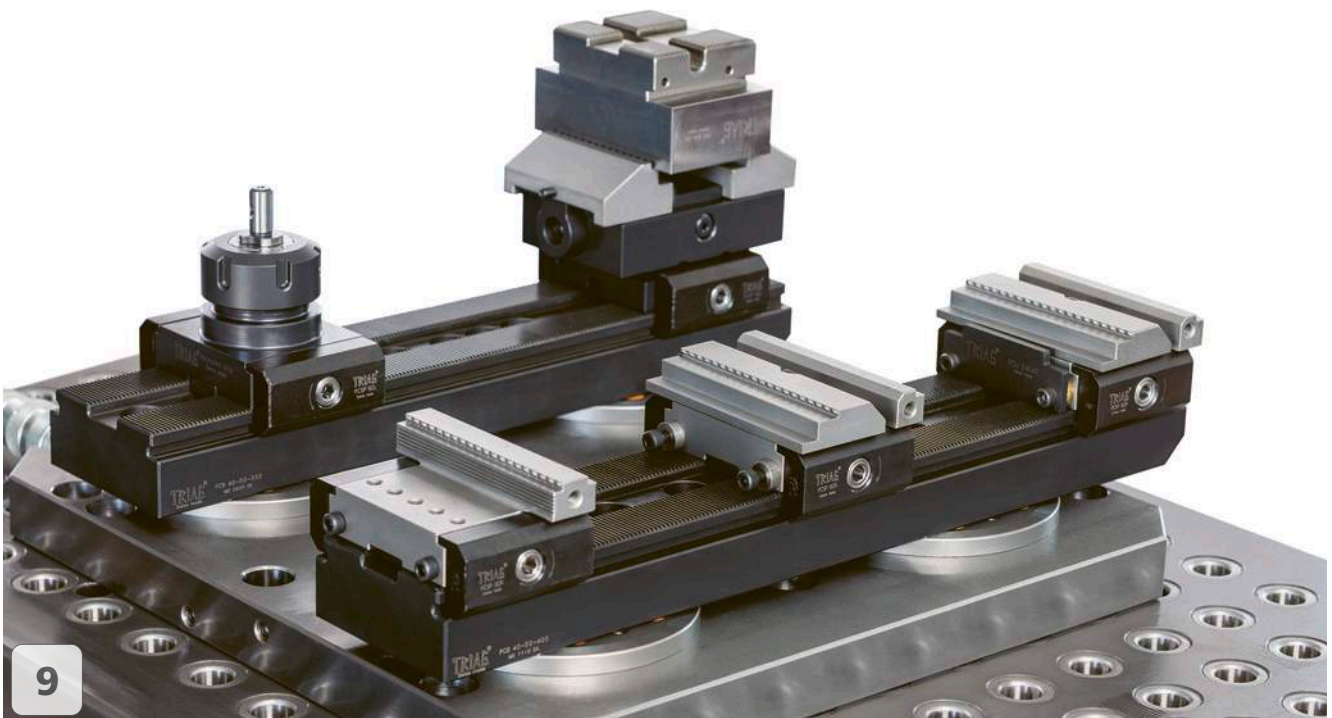
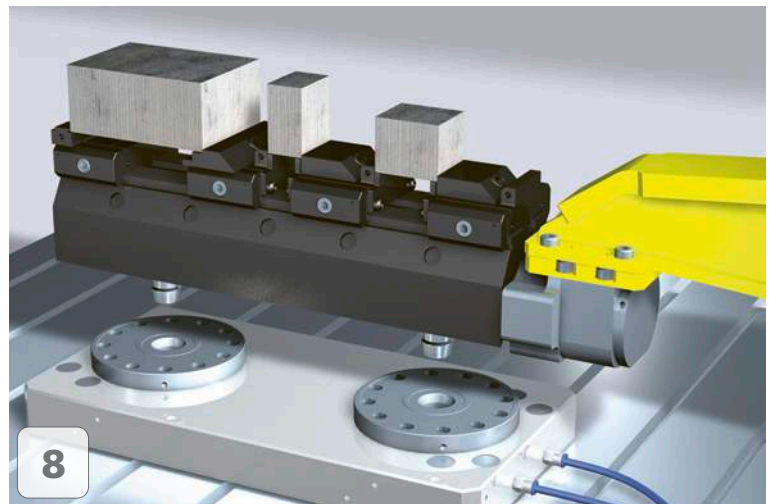
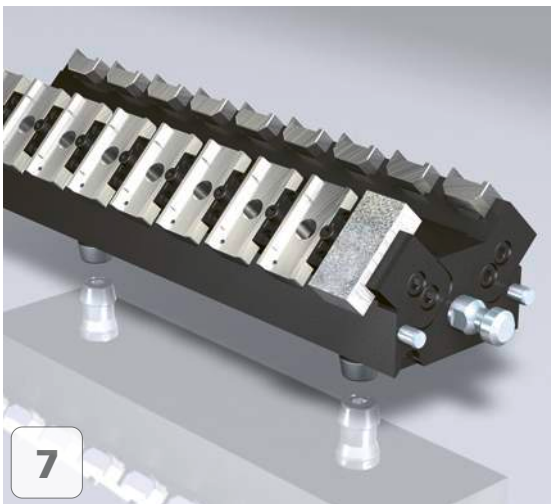

Mechanisches Nullpunktsystem mit diversen Spannlösungen

Mechanical zero point system with different workholding solutions

Da die Anforderungen an „just in time“ Produktion in den letzten Jahren stetig gewachsen sind, ist ein modulares Nullpunkt Schnellwechselsystem der richtige Weg um lange Standzeiten der Werkzeugmaschine zu verhindern.

Since the requirements for „just in time“ production have grown steadily in the recent years, a modular zero-point quick-change system is the right way to prevent long down time of a machine.

- ✓ **Sehr tiefe Bauhöhe (28 mm)**
- ✓ **Wiederholgenauigkeit 0.01 mm**
- ✓ **6000 dAN Haltekraft**
- ✓ **Abhebefunktion ein- und ausschaltbar (3-4 mm)**

- ✓ **Very low height (28mm)**
- ✓ **Repeat accuracy of 0.01mm**
- ✓ **6000daN holding force**
- ✓ **Lift-off function can be switched on and off (3-4 mm)**

triCENTRO p. 141

140x120x83
Erhältlich in 4 versch. Größen
Available in 4 sizes
140x120x83 / 160x120x83
180x120x83 / 200x120x83

triCENTRO p. 119

Ø176, H=129

0-Punkt Basis / 0-point base kg

A	OPBM4Q100R50	~3,8
B	OPBM4Q100R200	~7,6
C	OPBM4Q100D184	~7,6
D	ZF211785	~7,6

3-Backenfutter / 3-jaw chuck kg

	OPM3X80L75	~5,8
1	OPM3X100L82	~7,3
	OPM3X125L88	~9,5

Zentrischspanner / Self centering vise

	Spannbereich / Clamping area	kg
2	ZSX140L50UPRG-OPM	62-118 ~7,1
	ZSX160L50UPRG-OPM	62-138 ~7,7
	ZSX180L50UPRG-OPM	62-158 ~8,1
	ZSX200L50UPRG-OPM	62-178 ~8,8

spaceGRIP I kg

3	UB5AXMCZ4045SET8-OPBM	~6,2
---	-----------------------	------

PowerCLAMP Set kg

4	PCSET18250-OPM	
	1x PCSET18-250A / O3	~5,9
	2x PCSET18-L1 / B48-20	~2,65

Basisschiene diagonal / Baserail diagonal kg

5	PCSET18220W2-OPM	~8,2
---	------------------	------

PC Schiene / PC Rail 250 mm kg

6	PCB2550250-OPM	~4,8
---	----------------	------

Abdeckung / Cover kg

7	OPMAD	~0,8
---	-------	------

Erhöhung / Raiser block kg

8	OPUB150H44	~8,5
---	------------	------

Rasterplatte / Grid plate kg

9	OPM25-15R50H28	~7,7
---	----------------	------

Aluminiumplatte / Aluminium plate kg

10	OPM25-15RH40	~4,3
----	--------------	------

Art. Nr.	kg	
OPBM4Q100R200	~4,3	

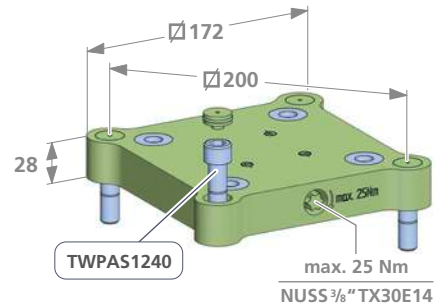

Art. Nr.	kg	
OPBM4Q100D184	~4,7	

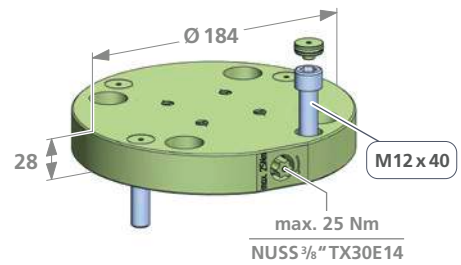

Art. Nr.	kg	
OPBM4Q100R50	~3,8	

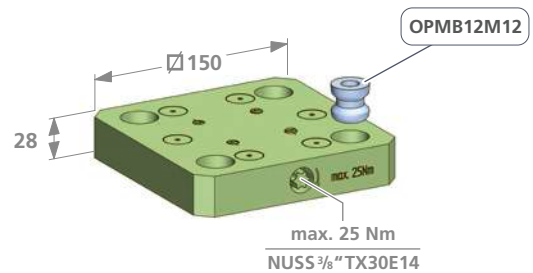

Positionier-Flansch Positioning-flange

Art. Nr.	A	Ø	kg	
ZF211785	235	250	~7,6	
ZF222333	172	180	~3,7	

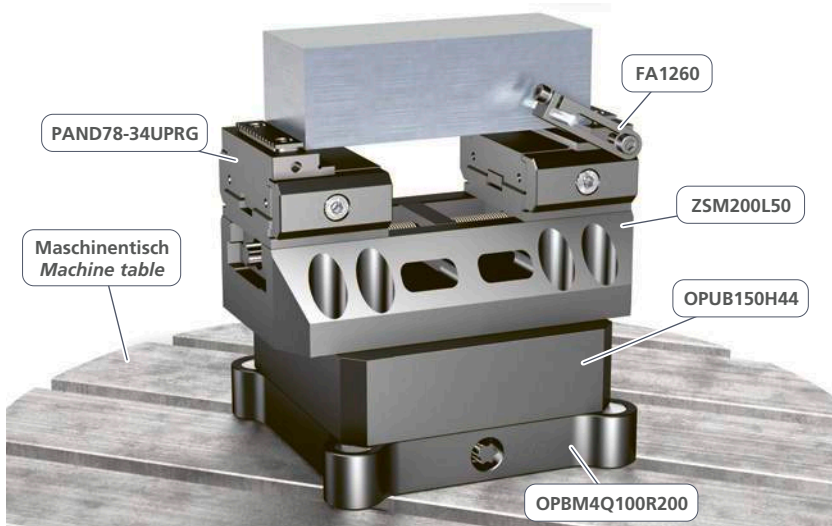
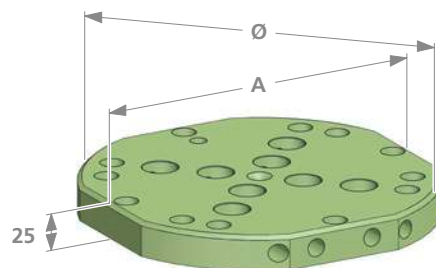

Die Verbindung zwischen Maschinentisch und dem opp-Schnellwechselsystem
The connection between the machine table and the opp-quick-change system

4-Achs Lösung für mechanische 0-Punkt Schnellwechselsysteme

4-axis solution for mechanical 0-point quick change systems

oppSystem

Winkel für die 4-Achse
Angle for the 4-axis

Art. Nr.	Y	kg
WU-18	180	~14,1
WU-25	244	~16

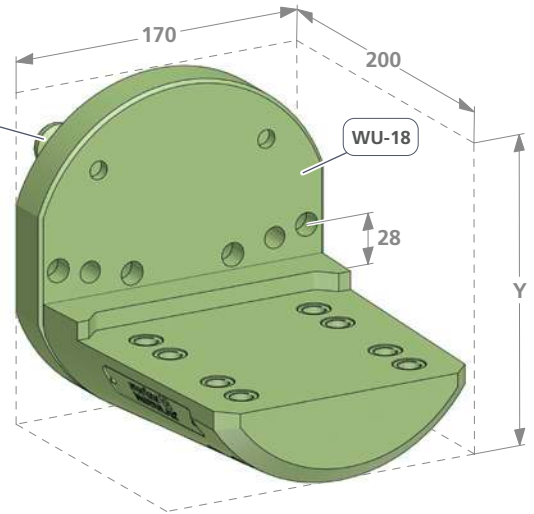
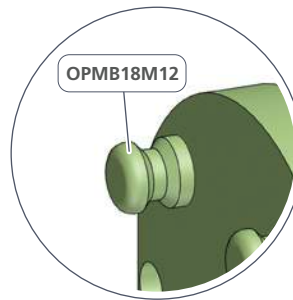

Flansch / Flange
Optional erhältlich
Optional accessory

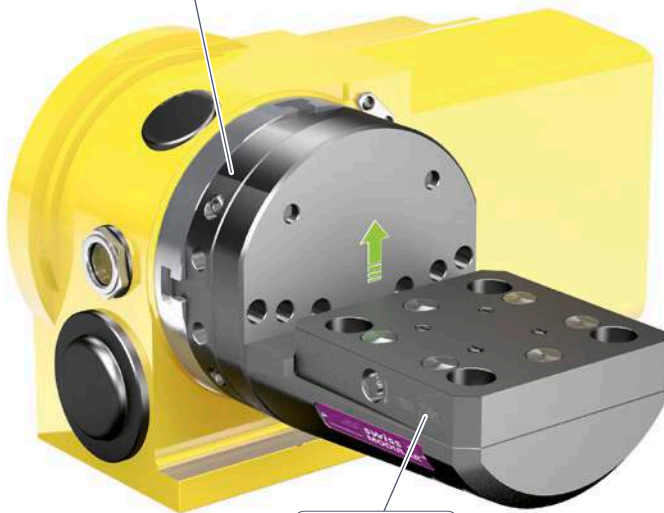

OPBM4Q100R50

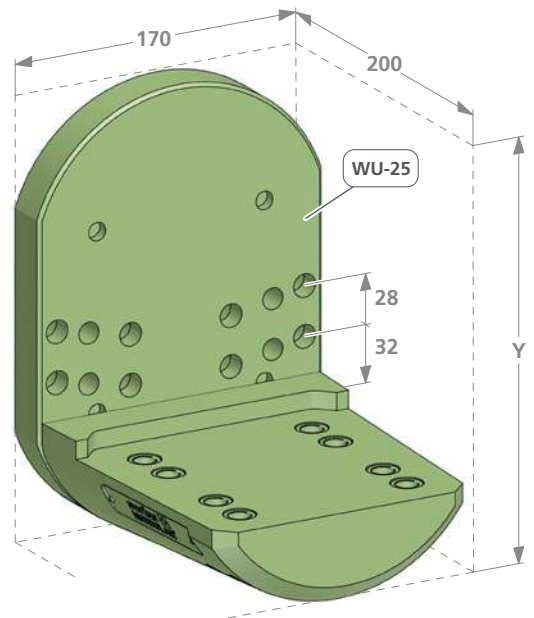

ZSX140L50UPRG

Bei diesen Winkeln kann die Brücke für die Aufnahme der Spannmittel inklusive Werkstücke in der Höhe angepasst werden.

With these angles, the bridge can be adjusted in height to accommodate the clamping devices including workpieces.

0-Punkt Erhöhung & Ausrichtplatte

Zero point riser & Alignment plate

oppSystem

0-Punkt Erhöhung Zero point riser

Art. Nr.	kg	QR
OPUB150H44	~8,5	

Optimal kombinierbar mit der Erhöhung (OPUB150H44) für eine bessere Zugänglichkeit zum Werkstück.

Ideally combined with the riser (OPUB150H44) for better access to work piece.

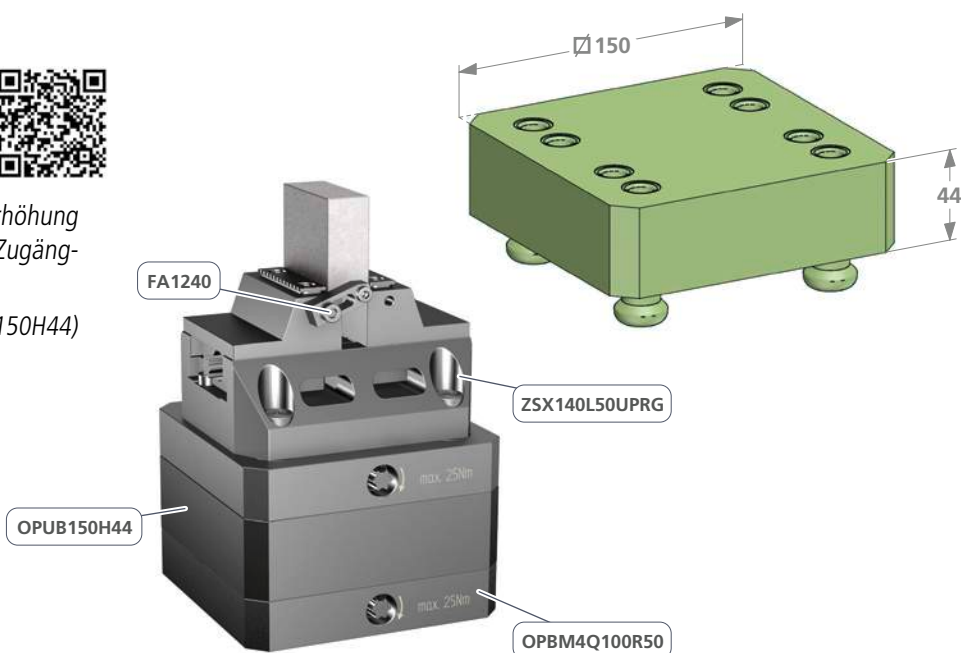

Ausrichtplatte Alignment plate

Art. Nr.	kg
OPMAW	~3,54

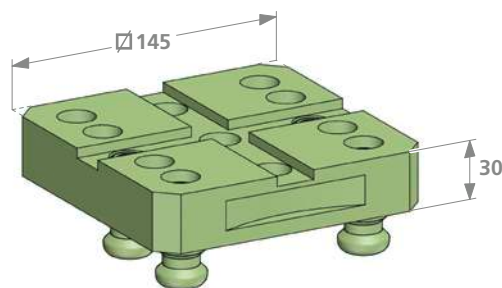
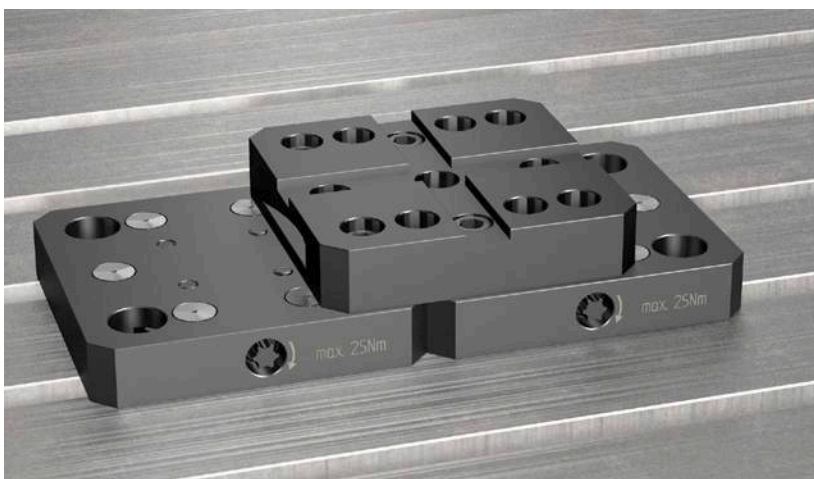

Diese Platte dient zum Ausrichten auf dem T-Nutentisch.

This plate is used to align on the T-slot table.

Nullpunkt Zentrier- und Klemmbolzen Zero point pull studs	Nullpunkt Schwertbolzen Diamond pull studs	Klemmbolzen mit Untermass Pull studs with minus tolerance	Schutzbolzen Protection bolts
 kg ~0,1 OPMB18M12	 kg ~0,1 OPMB18M12S	 kg ~0,1 OPMB18M12U	 kg ~0,08 OPMBL
 kg ~0,06 OPMB12M12	 kg ~0,06 OPMB12M12S	 kg ~0,06 OPMB12M12U	 kg ~0,07 OPMBL-25

Dreibackenfutter
Three-jaw chuck

OPM3X80L75
OPM3X100L82
OPM3X125L88

oppSystem

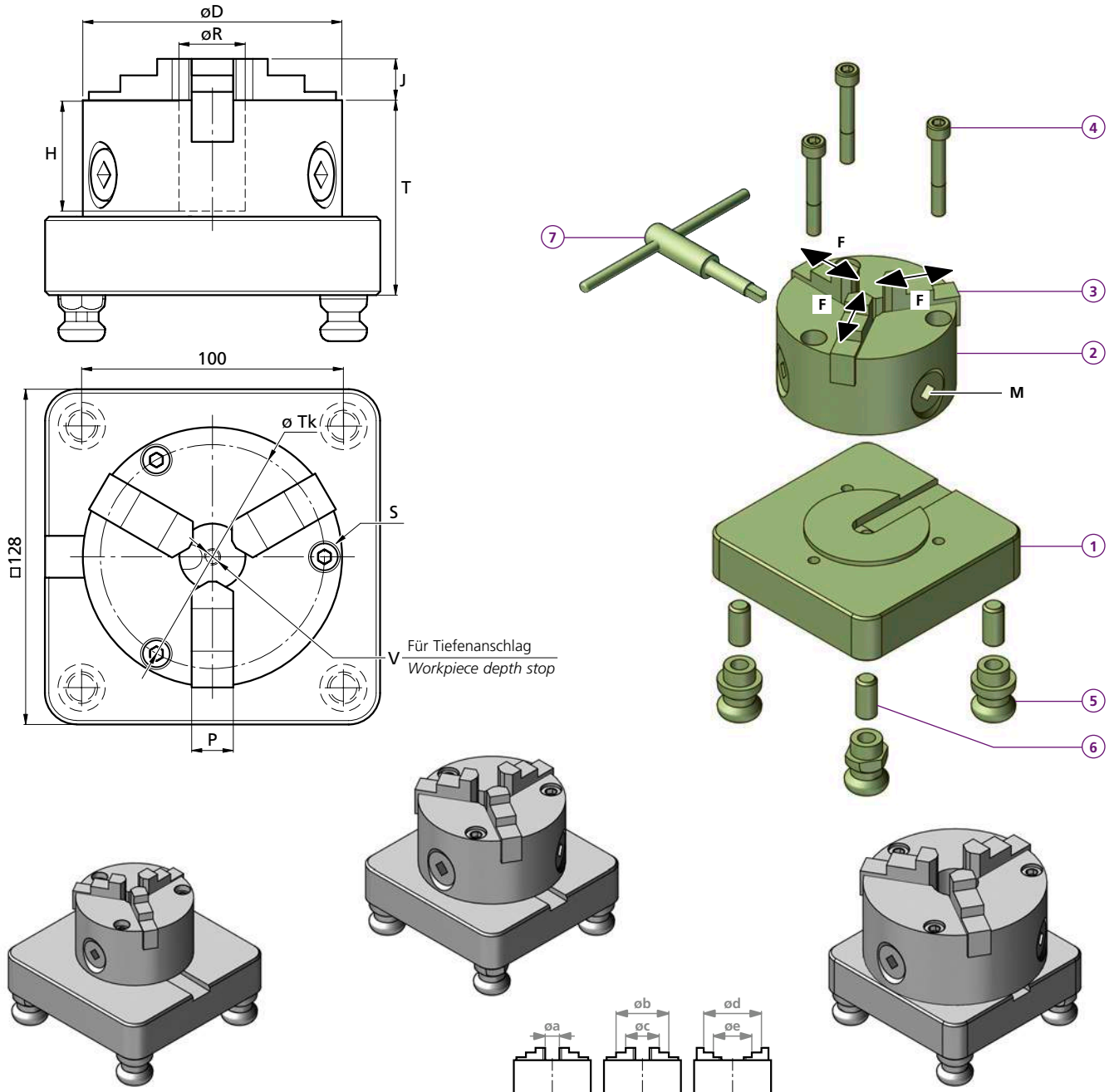

	D	J	T	R	H	P	V	a mm	b mm	c mm	d mm	e mm	M (max.)	F (max.)	$\varnothing Tk$	S
OPM3X80L75	80	13	75	15	42,5	10	M6	3...27	48...73	23...48	52...76	27...51	28 Nm	1300 daN	67	M6
OPM3X100L82	100	17	82	20	49,5	14	M8	3...39	58...94	24...60	64...100	30...66	38 Nm	1600 daN	83	M8
OPM3X125L88	125	19	88	32	55	16	M8	3...49	70...116	30...75	83...125	38...84	55 Nm	2600 daN	108	M8

	OPM3X80L75	OPM3X100L82	OPM3X125L88
1	1x TB161207	1x TB161208	1x TB161209
2	1x 243809.0083220	1x 243809.0103220	1x 243809.0123220
3	2x 3 Stk. / pcs	2x 3 Stk. / pcs	2x 3 Stk. / pcs
4	3x TN100346	3x TN100360	3x TN100361
5	1x OPMB18M12	1x OPMB18M12	1x OPMB18M12
6	2x OPMB18M12U	2x OPMB18M12U	2x OPMB18M12U
7	1x OPMB18M12S	1x OPMB18M12S	1x OPMB18M12S
8	4x TN100067	4x TN100067	4x TN100067
9	1x 243864.0080000	1x 243864.0100000	1x 243864.0120000
kg	~ 5,8	~ 7,3	~ 9,5

243849.0083200
243849.0103200
243849.0123200

B

3x
 $\varnothing 3 - 49$

243850.0083200
243850.0103200
243850.0123200

B

3x
 $\varnothing 38 - 125$

*243834.0083300
*243834.0103300
*243834.0123300

3x
*Weich
Soft
16MnCr5

Separat bestellen / Order separately

Bestellbeispiel / Ordering example: **OPM3X80L75**

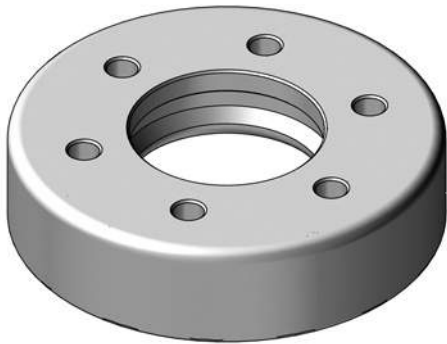

OP92BUE23

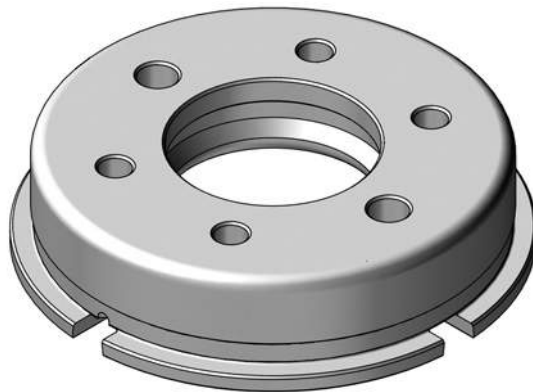

OP92BUE23ID

	kg
OP92BUE23	~0,75
OP92BUE23ID	~0,78

Bestellbeispiel / Ordering example: **OP92BUE23**

Einbauanleitung / Assembling instructions

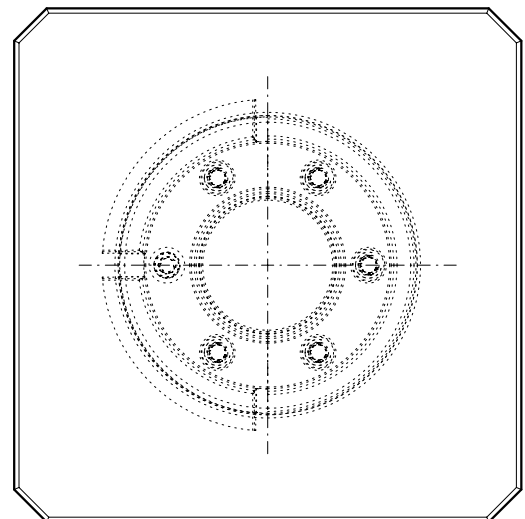
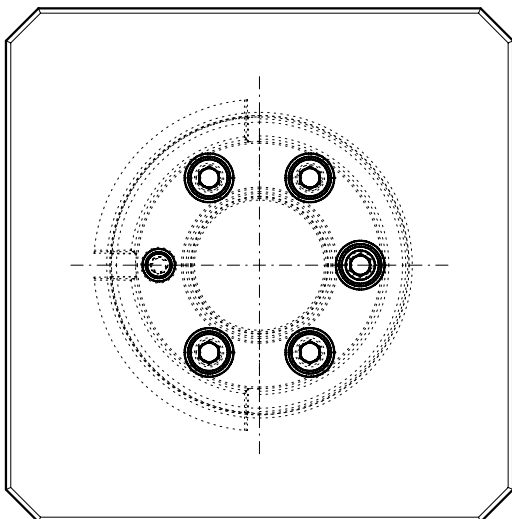
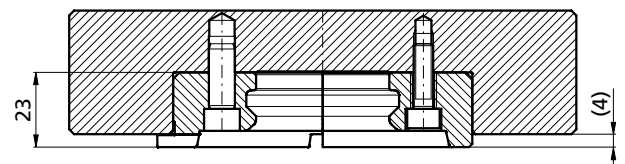
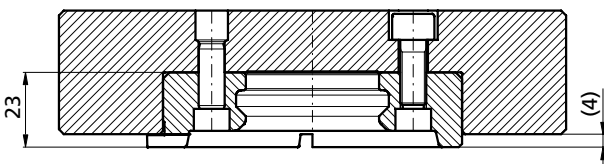
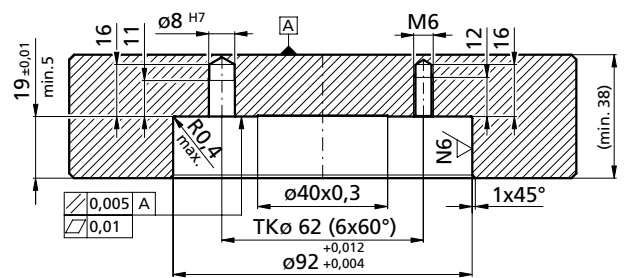
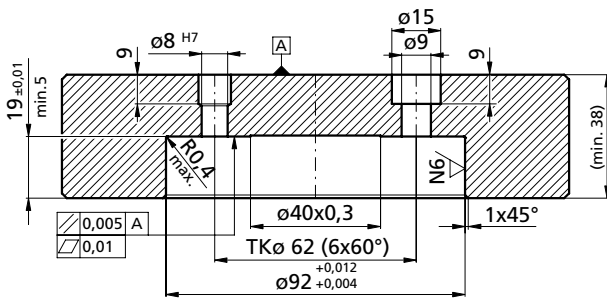

Zentriereinheit
Chuck unit

Zentrierkörper
Chuck body

oppSystem

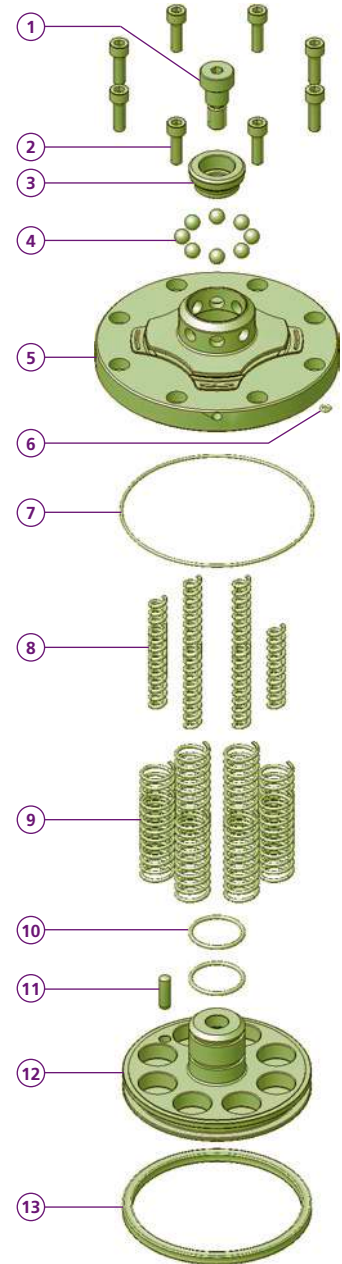
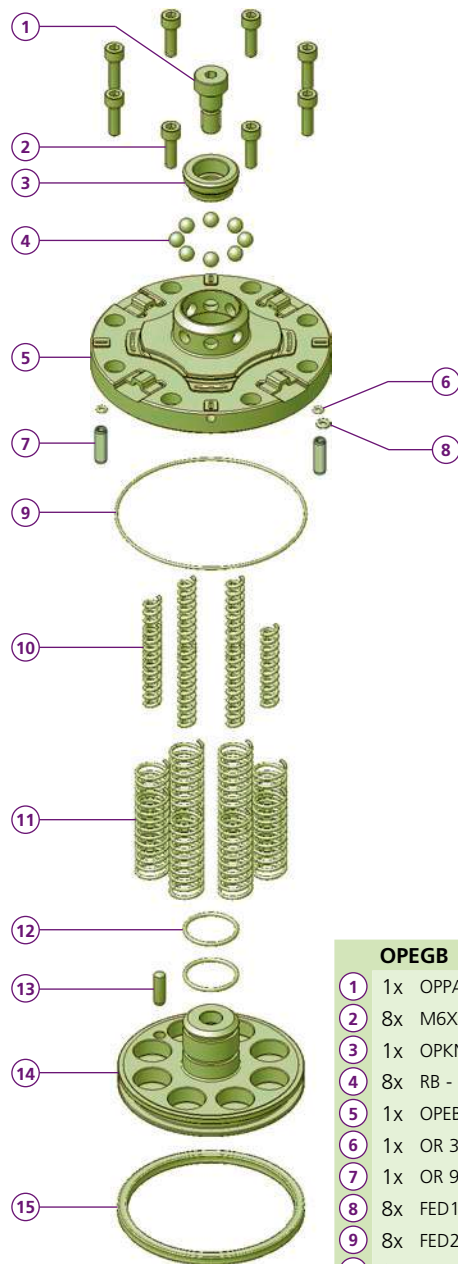
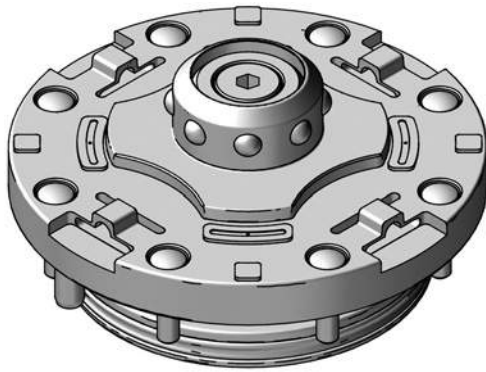

OPEGBID (Index)

- ① 1x OPPAS M10x12
- ② 8x M6X20 ST
- ③ 1x OPKN 30x13,5
- ④ 8x RB - 8/G20W
- ⑤ 1x OPEBID
- ⑥ 1x OR 3x1,5
- ⑦ 2x **CCBO0801**
- ⑧ 1x OR 5x1,5
- ⑨ 1x OR 90x1,5
- ⑩ 8x FED1044
- ⑪ 8x FED2051
- ⑫ 2x OR 26x2
- ⑬ 1x 6m6x20 DIN 6325
- ⑭ 1x OPKLB100
- ⑮ 1x OPDR885

kg ~2,28

OPEGB

- ① 1x OPPAS M10x12
- ② 8x M6X20 ST
- ③ 1x OPKN 30x13,5
- ④ 8x RB - 8/G20W
- ⑤ 1x OPEB
- ⑥ 1x OR 3x1,5
- ⑦ 1x OR 90x1,5
- ⑧ 8x FED1044
- ⑨ 8x FED2051
- ⑩ 2x OR 26x2
- ⑪ 1x 6m6x20 DIN 6325
- ⑫ 1x OPKLB100
- ⑬ 1x OPDR885

kg ~2,26

Bestellbeispiel
Ordering example: OPEGBID

1er Palettenträger

Receiver chuck with 1 chucks

oppSystem

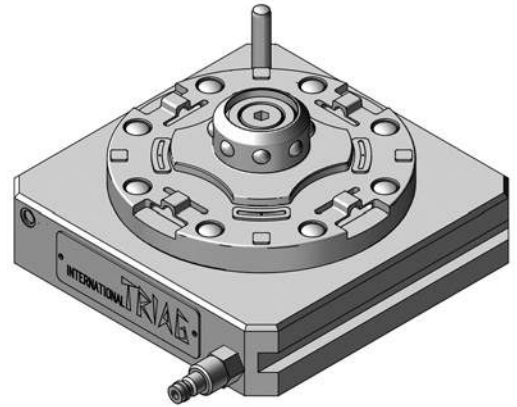
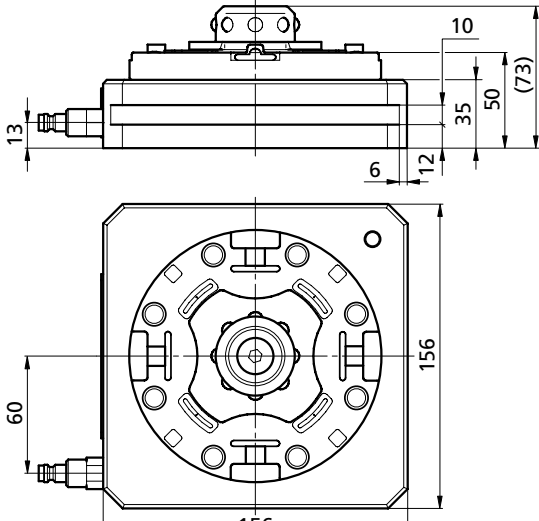

Bestellbeispiel / Ordering example : **OPB1ID**

	kg
OPB1ID (Index)	~7,6

1er Palette

Pallet with 1 clamping case

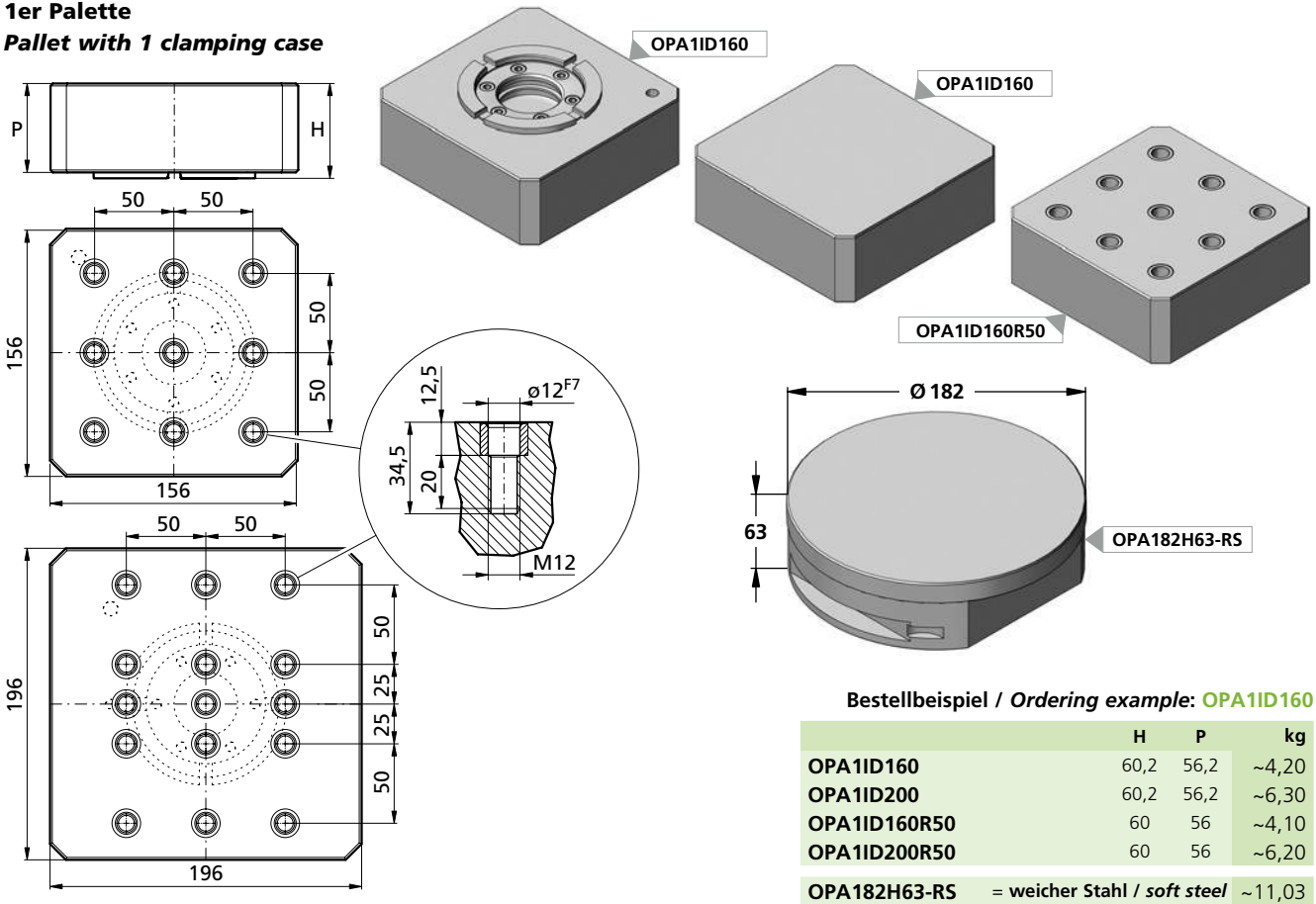

Bestellbeispiel / Ordering example: **OPA1ID160**

	H	P	kg
OPA1ID160	60,2	56,2	~4,20
OPA1ID200	60,2	56,2	~6,30
OPA1ID160R50	60	56	~4,10
OPA1ID200R50	60	56	~6,20
OPA182H63-RS	= weicher Stahl / soft steel		~11,03

Basis mit integrierter 0-Punkt Index Aufnahme oppSystem

Base rail with integrated oppSystem index

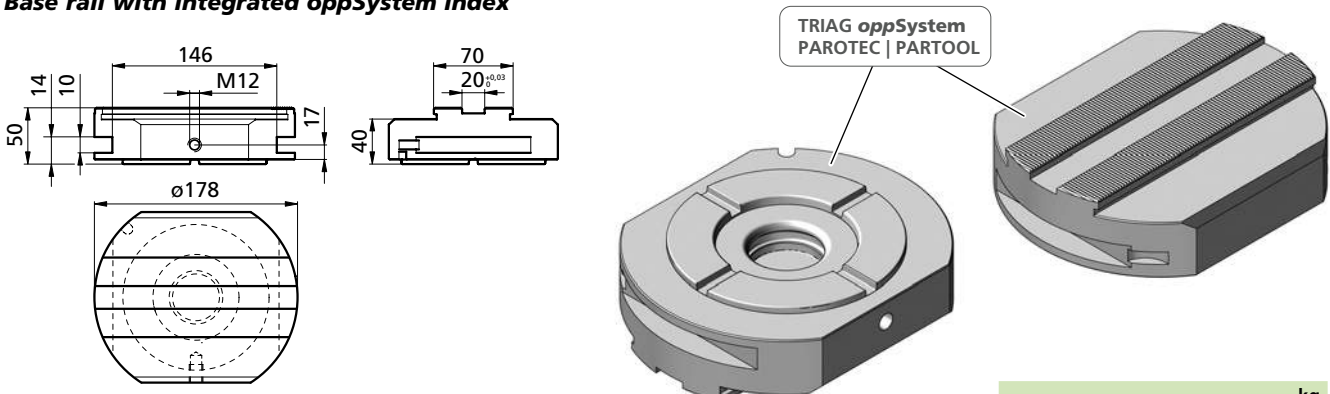

Bestellbeispiel / Ordering example: **OPA1IDPCB178**

	kg
OPA1IDPCBD178	~8,0

2er Palettenträger

Receiver chuck with 2 chucks

oppSystem

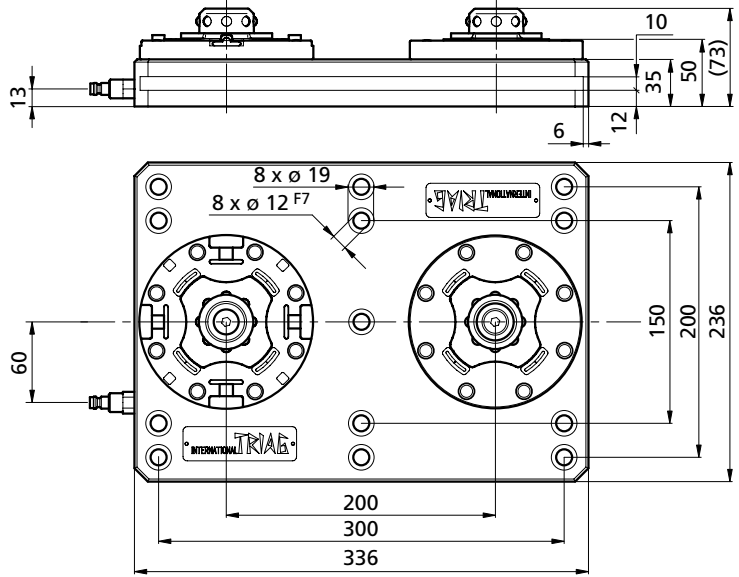
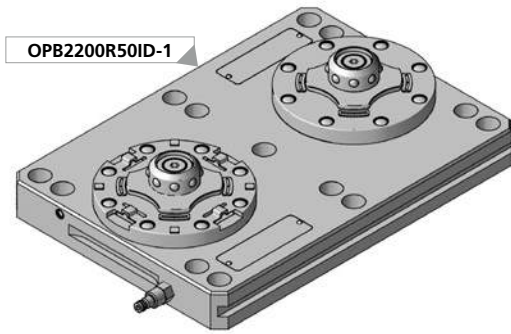

	kg
OPB2200R50	~27,60
OPB2200R50ID-1 (Index)	~30,00
OPB2200R50ID-2 (Index)	~30,00

Bestellbeispiel / Ordering example: **OPB2200R50**

2er Palette

Pallet with 2 clamping case

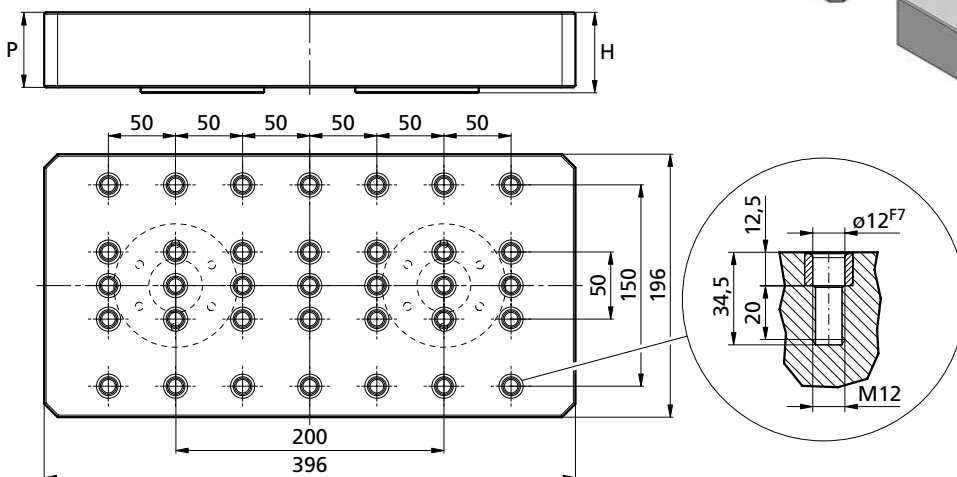
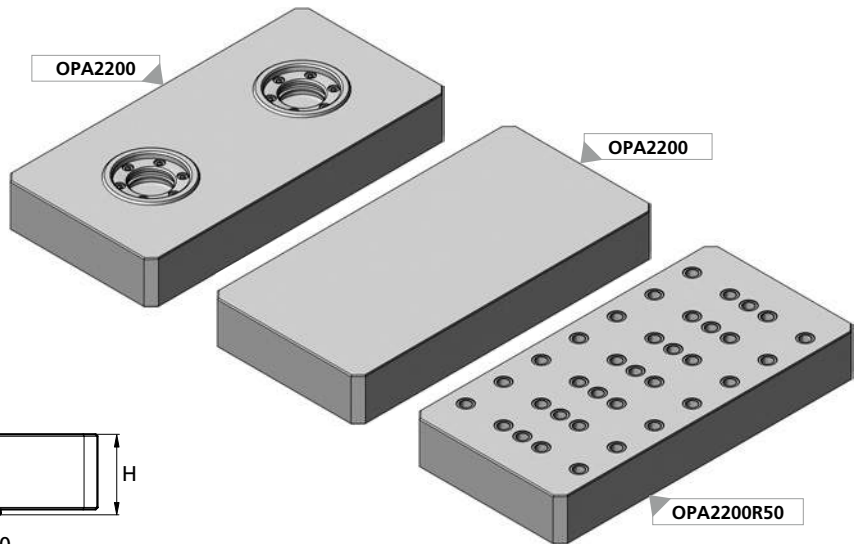

	H	P	kg
OPA2200	60,2	56,2	~12,18
OPA2200R50	60	56	~12,50

Bestellbeispiel / Ordering example: **OPA2200R50**

3er Palettenträger

Receiver chuck with 3 chucks

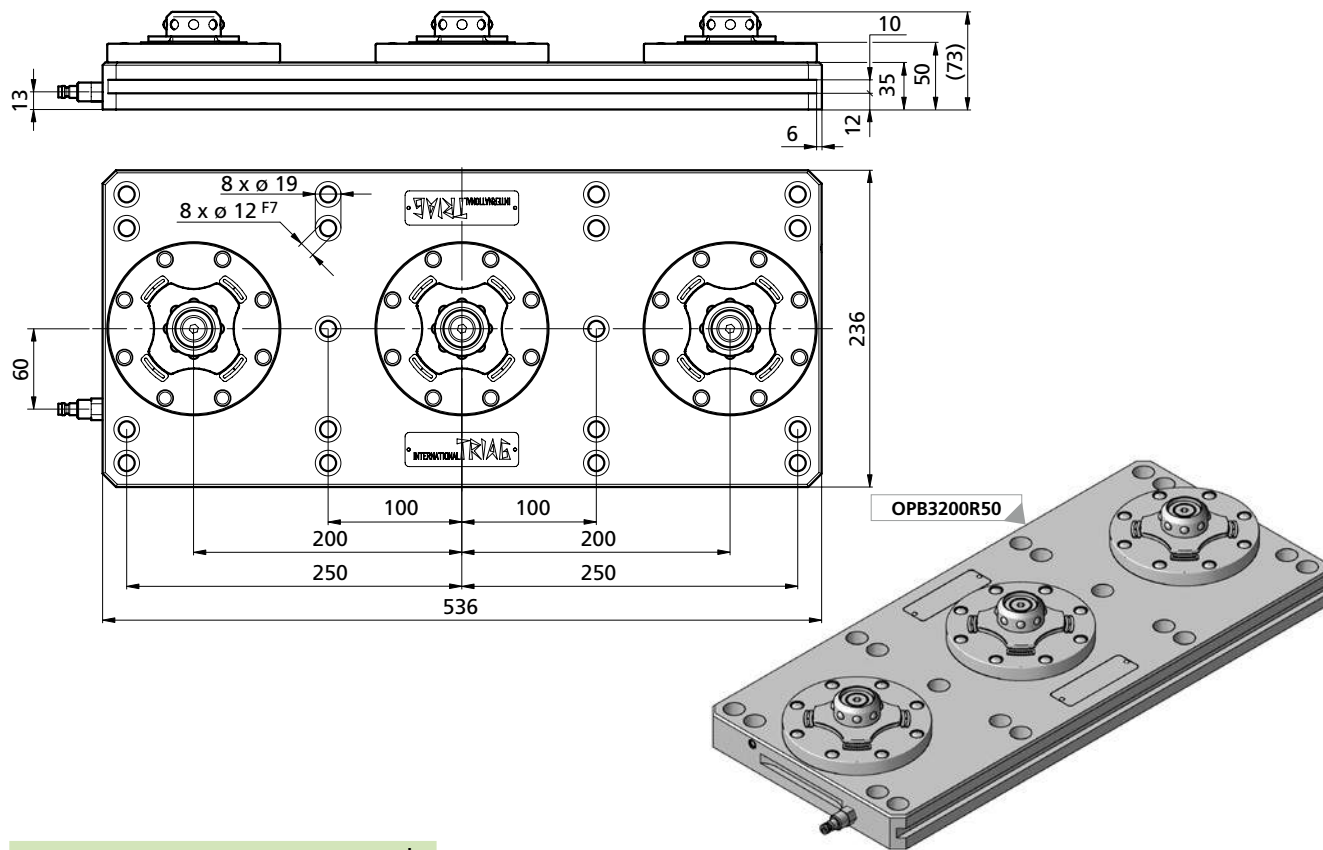

	kg
OPB3200R50	~36,10
OPB3200ID-1 (Index)	~36,00

Bestellbeispiel / Ordering example: **OPB3200R50**

3er Palette

Pallet with 3 clamping case

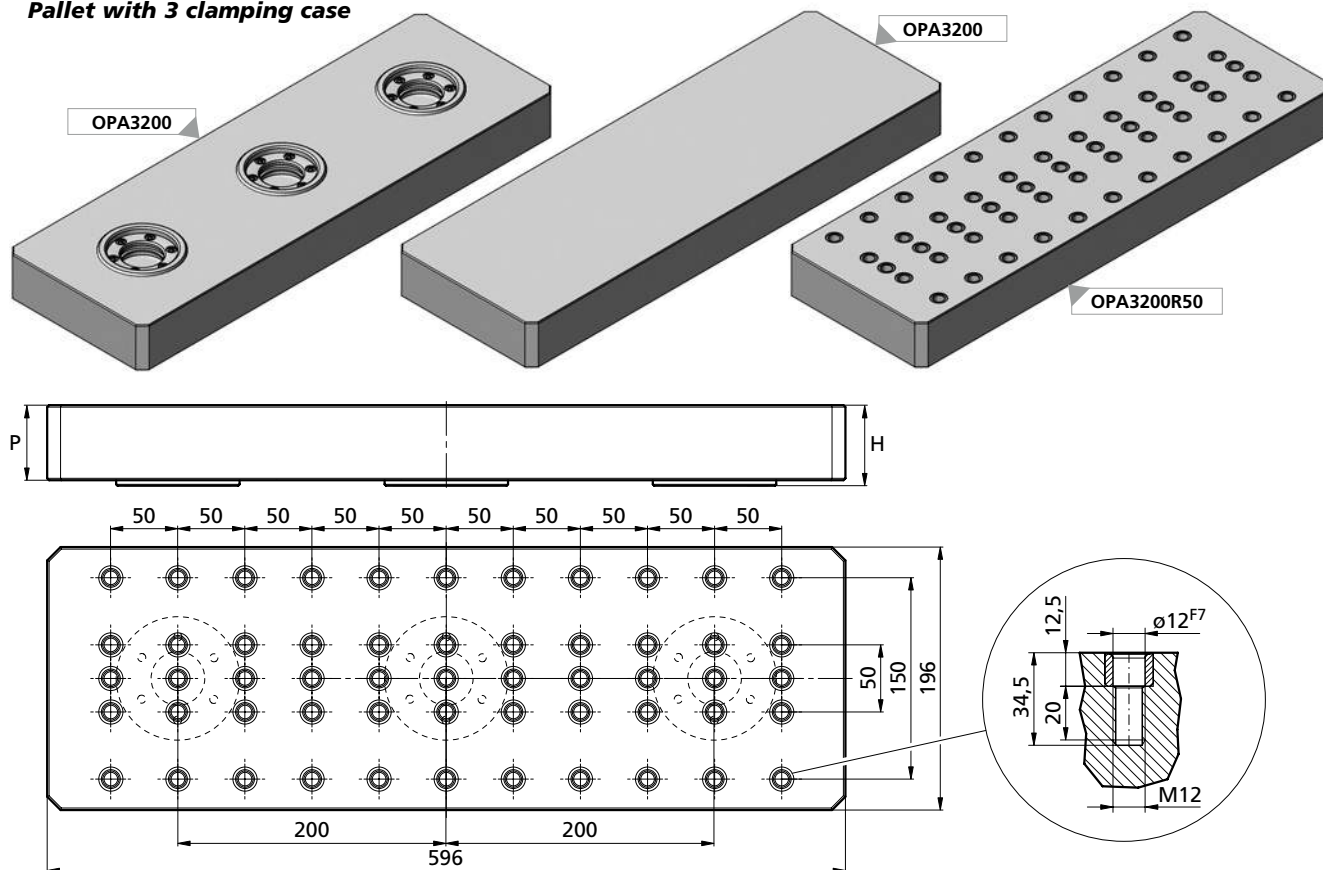

	H	P	kg
OPA3200	60,2	56,2	~18,90
OPA3200R50	60	56	~18,80

Bestellbeispiel / Ordering example: **OPA3200**

4er Palettenträger

Receiver chuck with 4 chucks

oppSystem

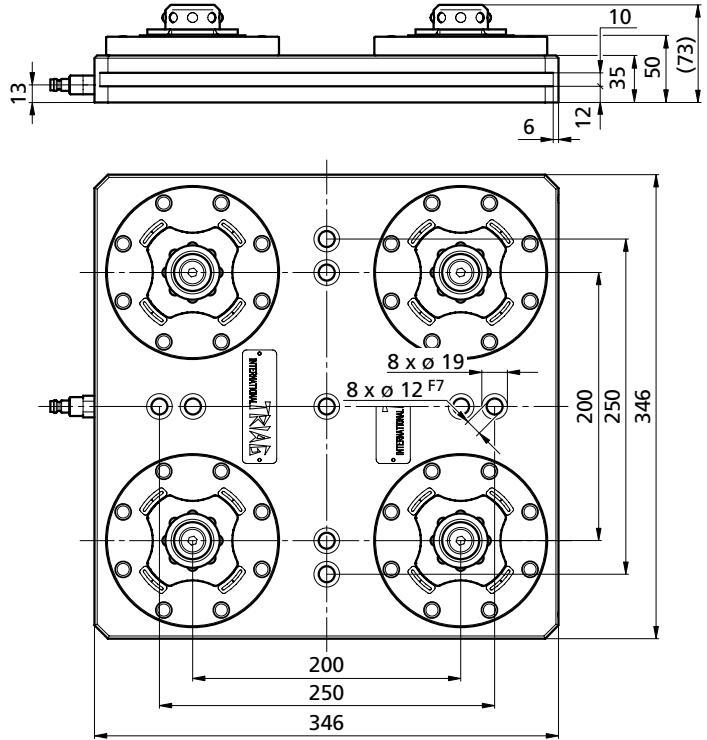
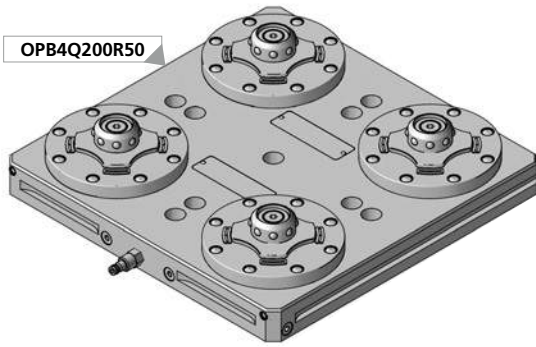

	kg
OPB4Q200R50	~35,80
OPB4Q200R50ID-4	~35,70

Bestellbeispiel / Ordering example: **OPB4Q200R50**

4er Palette

Pallet with 4 clamping case

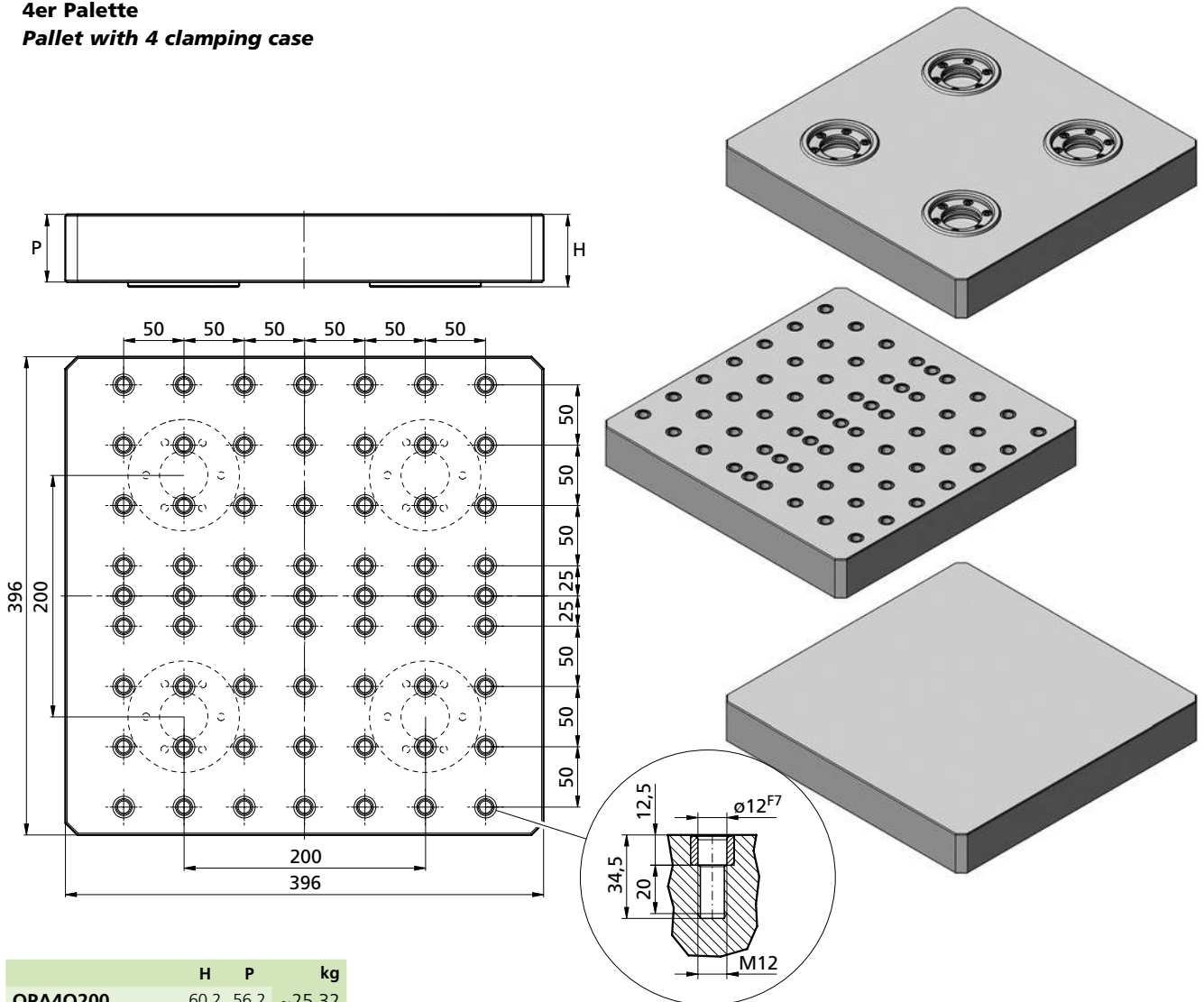

	H	P	kg
OPA4Q200	60,2	56,2	~25,32
OPA4Q200R50	60	56	~25,23

Bestellbeispiel / Ordering example: **OPA4Q200**

EROWA MTS Einbauspannfutter / Integral chucks

Einbauvariante (gültig für MTS IntegralChuck Single und Multi). Toleranzen entsprechend der Einbauanleitung beachten!

Integration variant (applicable to MTS IntegralChucks Single and Multi). Observe tolerances according to integration instructions!

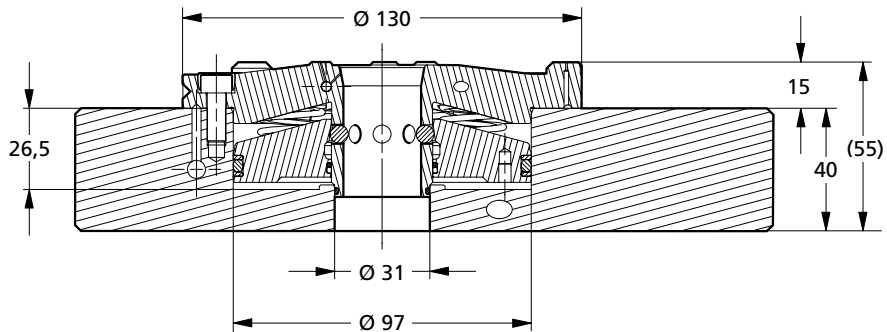

Manuelle Bedienung
Manual operation



Geeignet zur Anwendung unter Flüssigkeit
Suited for submerged operation



Geeignet für automatische Anwendung
Suited for automatic operation



Mit Druckluftpistole bedienen
Operate with compressed air jet



Für spanabhebende Bearbeitung
For chip-removing processes



Zum Senkerodieren
For EDM sinking

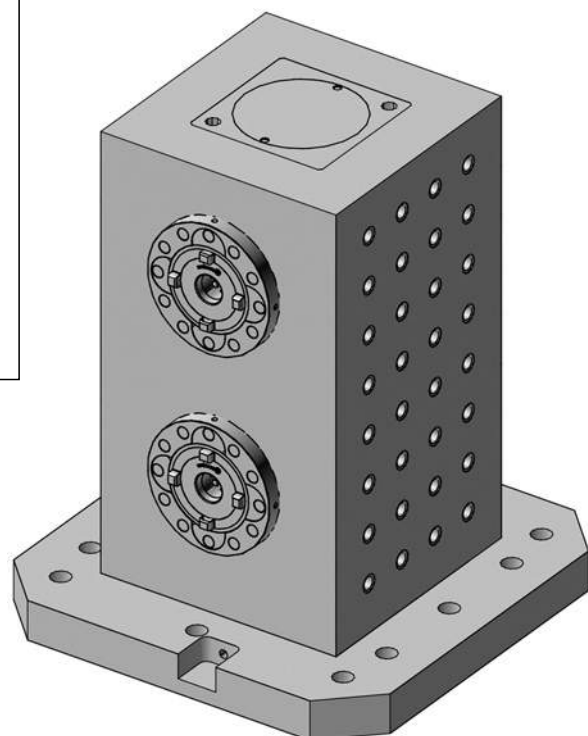

1 Präzise

Spielfreie Kurzkegel-Zentrierung.
 Repetiergenauigkeit: < 0,005 mm.
 Leichtes Einfahren der Paletten.

2 Spannmechanismus

Zuverlässiger Spannmechanismus durch selbsthemmenden Kugerverschluss.

3 Öffnen

MTS Spannfutter werden pneumatisch betätigt.

4 Sauberkeit

Flüssigkeit kann ablaufen, keine Schmutzecken.

1 Precise

Play-free round-cone centering.
 Repeatability: <0.005 mm.
 Easy insertion of the pallets.

2 Clamping mechanism

Reliable clamping mechanism through self-locking ball lock.

3 Open

MTS are operated pneumatically.

4 Cleanliness

Liquids can drain off. No dirt traps.

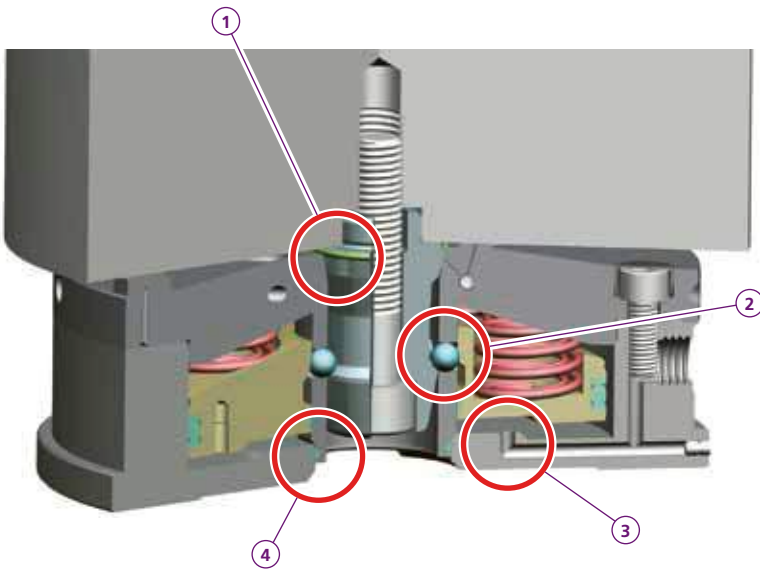

L x B x H: Maschinenabhängig
L x W x H: Depending on the machine

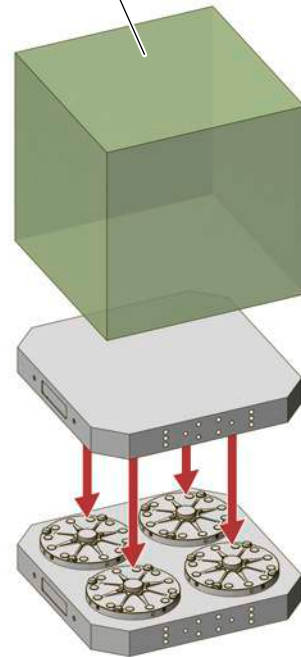

MTS Spannfutter

Das pneumatische MTS Spannfutter benötigt trotz der hohen Spannkraft von 12'000 N dank interner Kraftverstärkung nur 7 bar Öffnungsdruck.

MTS Chuck

A mere 7 bar of opening pressure results in 12,000 N clamping power thanks to internal power boosting.

MTS Spannfutter, automatisierbar

Automatische Reinigung der Auflageflächen und des Zentrierzapfens beim Werkstückwechsel.

MTS chuck, automatable

Automatic cleaning of contact surfaces and of the centering spigot cone while the workpiece is changed.

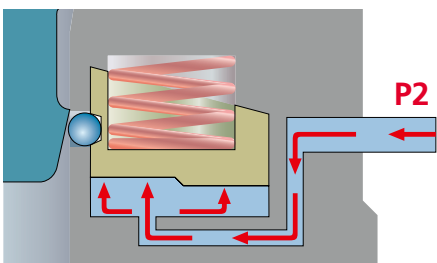

Anschluss (P2)
 Öffnen
Prise (P2)
 Ouverture

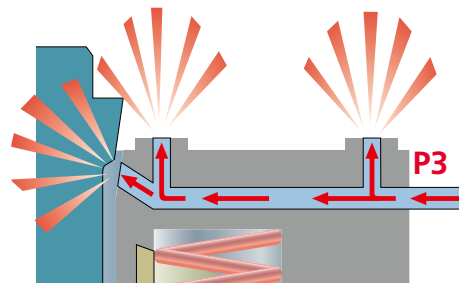

Anschluss (P3)
 Reinigen
Prise (P3)
 Cleaning

MTS IntegralChuck S-P (single + multiple / manually)

ER-033402



- Ausführung** Für den direkten Einbau in Maschinentische, Platten, Spanntürme, Winkel oder Teilapparate.
- Anschlüsse** Zum Öffnen: Pneumatisch.
- Anwendung** Zur Aufnahme von Einzel- oder Mehrfachpaletten.
- Version** For direct integration in machine tables, plates, tombstones, squares or dividing heads.
- Connections** To open: pneumatic or hydraulic.
- Application** To accommodate single or multiple pallets.

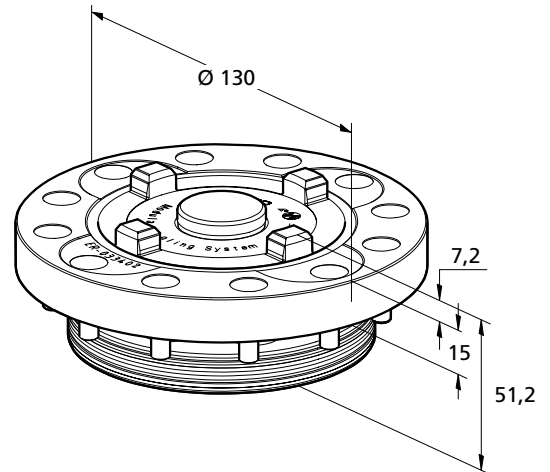

MTS IntegralChuck S-P/A (single + multiple / auto)

ER-036802



- Ausführung** Für den direkten Einbau in Maschinentische, Platten, Spanntürme, Winkel oder Teilapparate.
- Anschlüsse** Zum Öffnen: Pneumatisch.
Zum Reinigen: Pneumatisch.
- Anwendung** Zur Aufnahme von Einzel- oder Mehrfachpaletten.
- Version** For direct integration in machine tables, plates, tombstones, squares or dividing heads.
- Connections** To open: pneumatic.
To clean: pneumatic.
- Application** To accommodate single or multiple pallets.

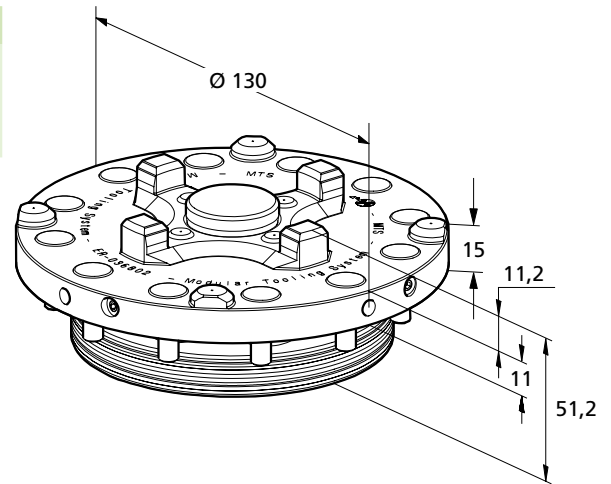

Spannzapfen / Spigot		
ER-033800	manuell / 0-Punkt Zapfen manually zero point locating	
ER-039201	auto / Ausgleichszapfen auto / alignment spigot	
ER-039200	auto / Zapfen mit Spiel auto / spigot with clearance	
ER-038000	auto / 0-Punkt Zapfen auto / Zero point spigot	

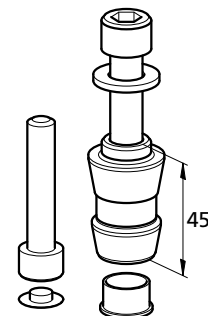

Um Ihnen die schnelle Orientierung über die Anwendungsbereiche der EROWA Produkte zu erleichtern, verwenden wir die folgenden Zeichen:
 To make it easier for you to find your way about the fields of application for EROWA products, we use the following symbols:

- S** = Single
- M** = Multi
- A** = Automatisierbar / Able to automate
- P** = Pneumatisch betätigt / Pneumatically operated

- Manuelle Bedienung
Manual operation
- Geeignet zur Anwendung unter Flüssigkeit
Suited for submerged operation
- Geeignet für die automatische Anwendung
Suited for automatic operation
- Für spanabhebende Bearbeitung
For chip-removing processes
- Zum Senkerodieren
For EDM sinking

MTS IntegralChuck M-P (multiple / manually)

ER-033400



- Ausführung** Für den direkten Einbau in Maschinentische, Platten, Spanntürme, Winkel oder Teilapparate.
- Anschlüsse** Zum Öffnen: Pneumatisch.
- Anwendung** Zur Aufnahme von Einzel- oder Mehrfachpaletten.
- Version** For direct integration in machine tables, plates, tombstones, squares or dividing heads.
- Connections** To open: pneumatic or hydraulic.
- Application** To accommodate single or multiple pallets.

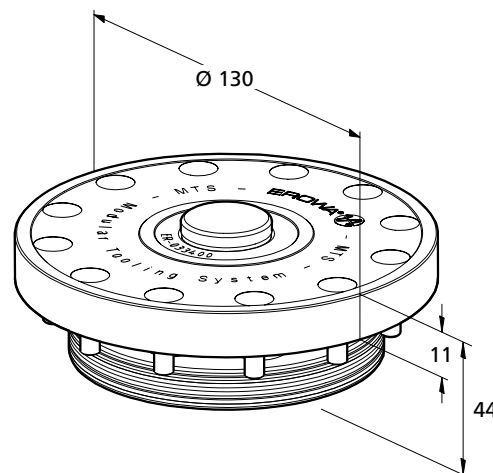

MTS IntegralChuck M-P/A (multiple / auto)

ER-036800



- Ausführung** Für den direkten Einbau in Maschinentische, Platten, Spanntürme, Winkel oder Teilapparate.
- Anschlüsse** Zum Öffnen: Pneumatisch.
Zum Reinigen: Pneumatisch.
- Anwendung** Zur Aufnahme von Einzel- oder Mehrfachpaletten.
- Version** For direct integration in machine tables, plates, tombstones, squares or dividing heads.
- Connections** To open: pneumatic.
To clean: pneumatic.
- Application** To accommodate single or multiple pallets.

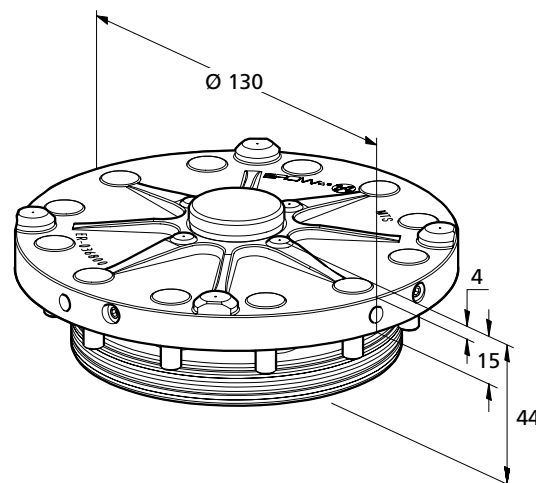

Spannzapfen / Spigot		
ER-033800	manuell / 0-Punkt Zapfen manually zero point locating	
ER-039201	auto / Ausgleichszapfen auto / alignment spigot	
ER-039200	auto / Zapfen mit Spiel auto / spigot with clearance	
ER-038000	auto / 0-Punkt Zapfen auto / Zero point spigot	

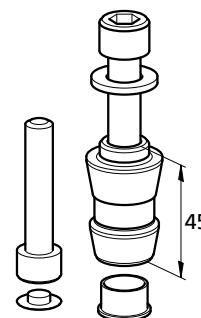

Um Ihnen die schnelle Orientierung über die Anwendungsbereiche der EROWA Produkte zu erleichtern, verwenden wir die folgenden Zeichen:

To make it easier for you to find your way about the fields of application for EROWA products, we use the following symbols:

- S** = Single
M = Multi
A = Automatisierbar / Able to automate
P = Pneumatisch betätigt / Pneumatically operated

- Manuelle Bedienung
Manual operation
- Geeignet zur Anwendung unter Flüssigkeit
Suited for submerged operation
- Geeignet für die automatische Anwendung
Suited for automatic operation
- Für spanabhebende Bearbeitung
For chip-removing processes
- Zum Senkerodieren
For EDM sinking

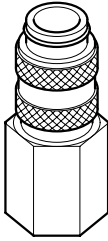
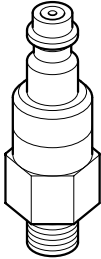
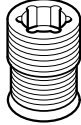
OPSKU	G1/4" Innengewinde <i>Internal thread</i>	OPST-NI	G1/8" Aussengewinde <i>Male thread</i>	OPRV	G1/8" Aussengewinde <i>Male thread</i>
 <p>Schnellkupplung <i>Quick fitting coupling</i></p>		 <p>Stecknippel verschmutzungsgeschützt <i>Plug nipple protected against staining</i></p>		 <p>Rückschlagventil <i>Nonreturn valve</i></p>	
OPANS-8 G1/4" Aussengewinde <i>Male thread</i>					

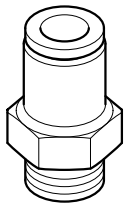

Für 8 mm Schlauch / *For hose*

Abdeckung
Cover

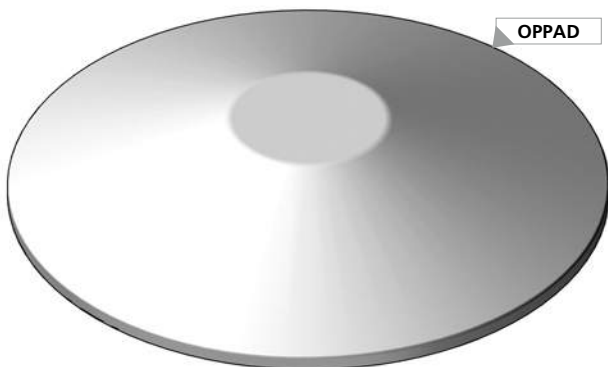

Dichtlippe
Leakproof cover

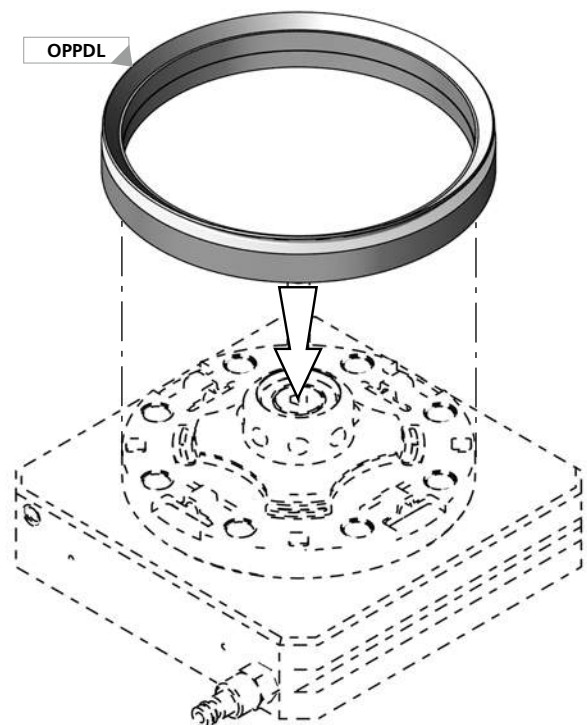

	kg
OPPDL	~0,525
OPPDL	~0,075

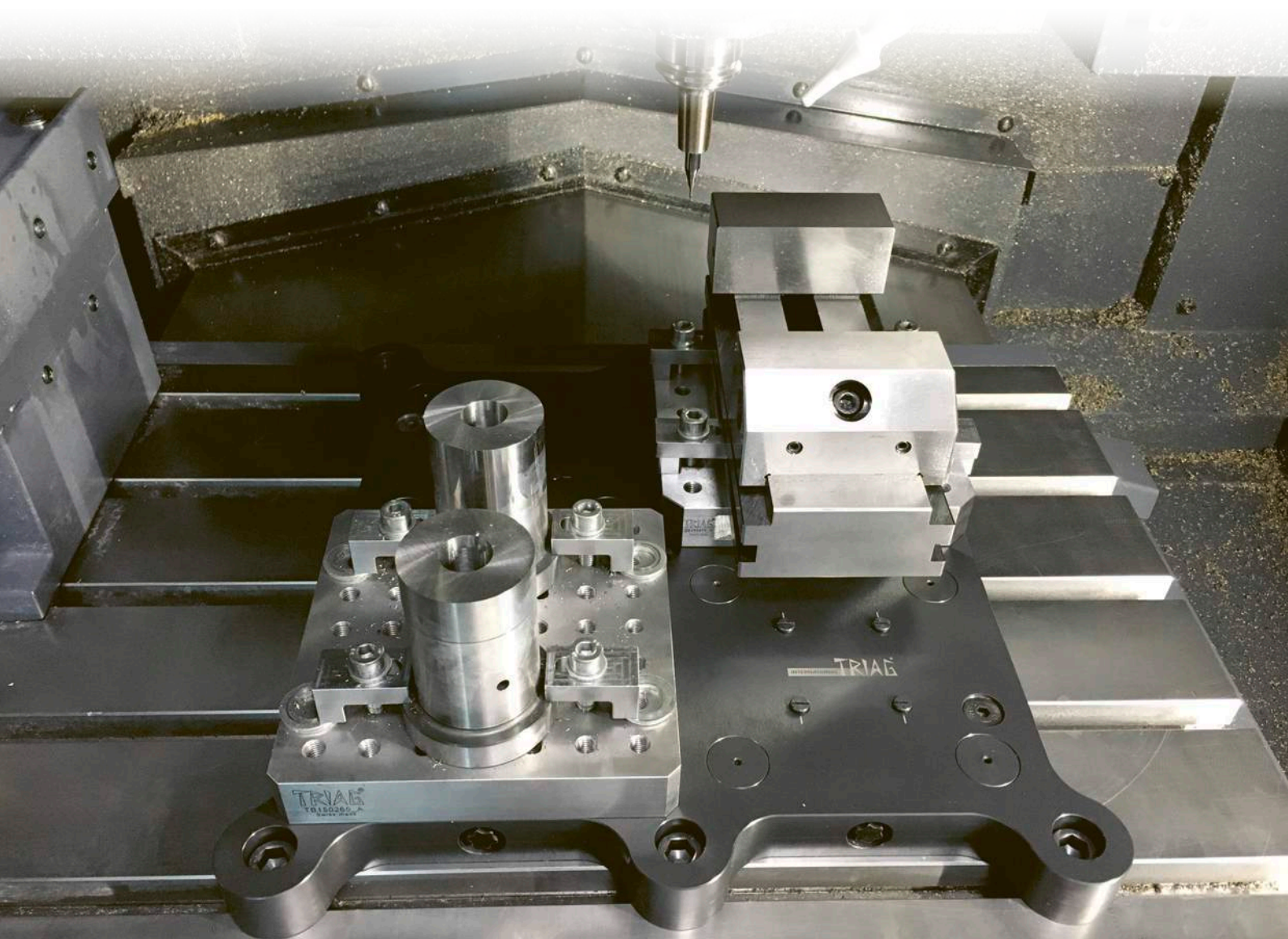

Bestellbeispiel / *Ordering example* : 1x **OPPDL**



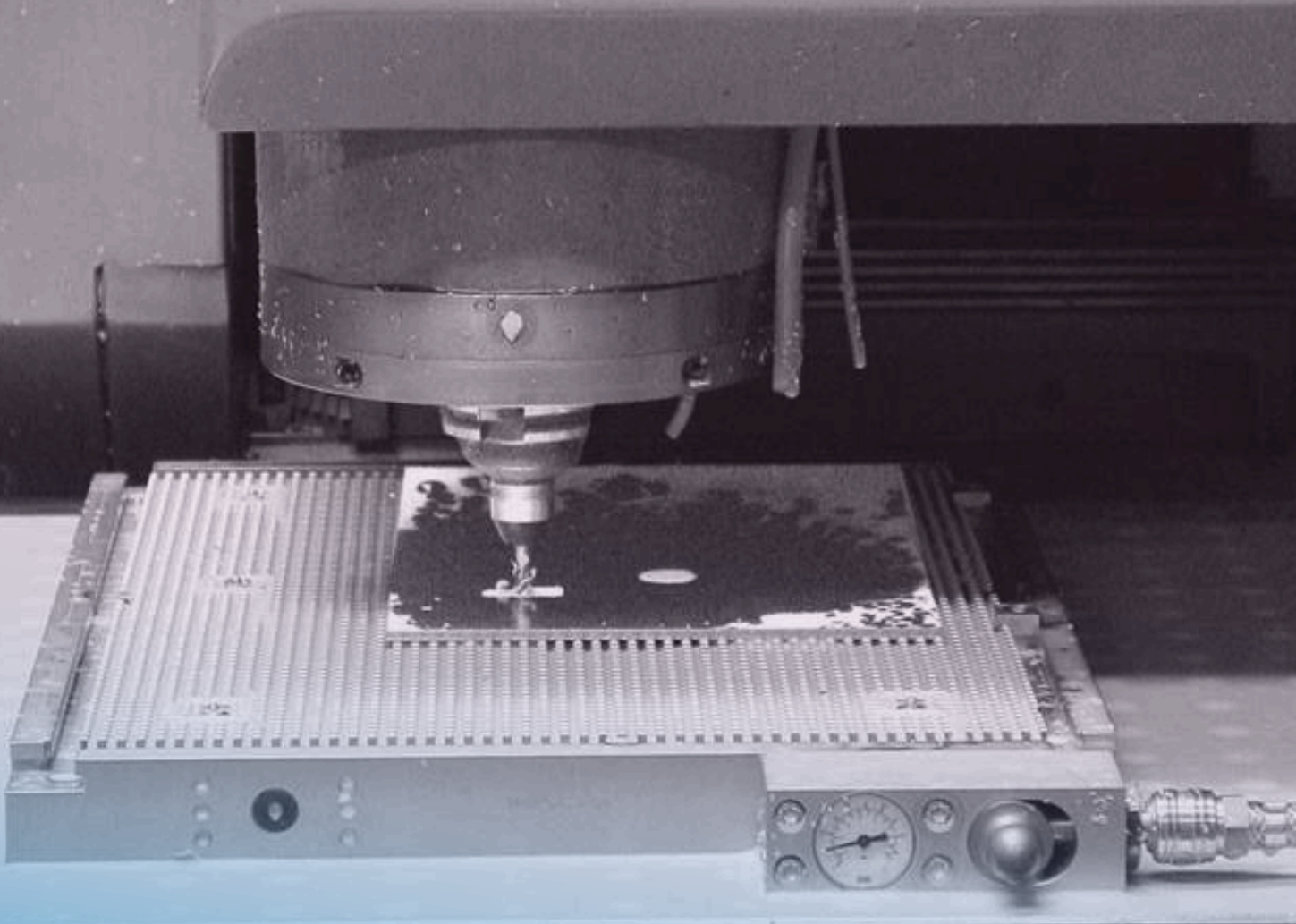

trivaCLAMP



	Einleitung <i>Introduction</i>	305 - 307
	Bedienungsanleitung <i>Operating manual</i>	308 - 309
	Anwendungsbeispiele <i>Examples of application</i>	310 - 312
	Modulare Vakuumplatten <i>Modular vacuum plates</i>	314 - 317
	Vakuum-Modul für powerCLAMP <i>Vacuum module for powerCLAMP</i>	318 - 319
	Kombinationsvarianten (Vakuumplatten) <i>Possible combination of vacuum plates</i>	320
	Startersets nach Ihrer Wahl <i>Starter kit (Your choice)</i>	321
	Zubehör <i>Accessories</i>	322 - 324
	Vakuum erzeugen <i>Generate vacuum</i>	325 - 327

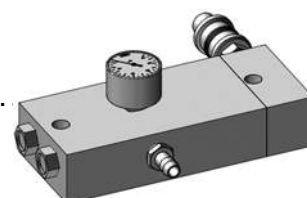
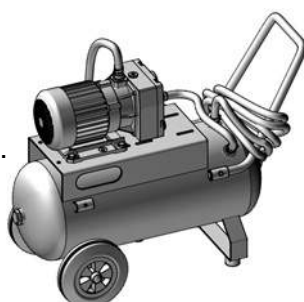
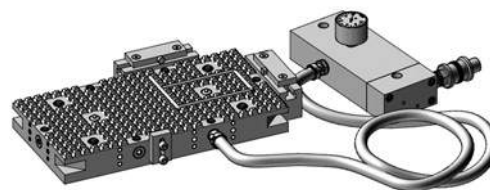
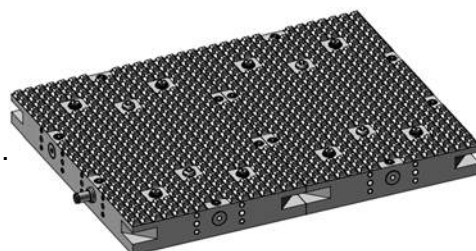
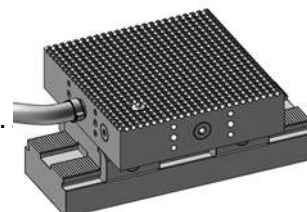
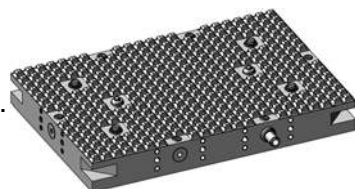

Vakuumpspannen

Die mechanische Spannung hat bekanntlich auch Nachteile. Hohe Kräfte auf das Werkstück können zu Druckmarken und Verformungen führen. Vor allem bei grösseren Werkstücken besteht zudem die Gefahr, dass das Werkstück vibriert.

Workholding by vacuum

Mechanical clamping, as described before, has disadvantages. High specific forces on the workpiece can cause pressure marks and distortions. And, particularly on large parts, there is a risk that the workpiece will vibrate.

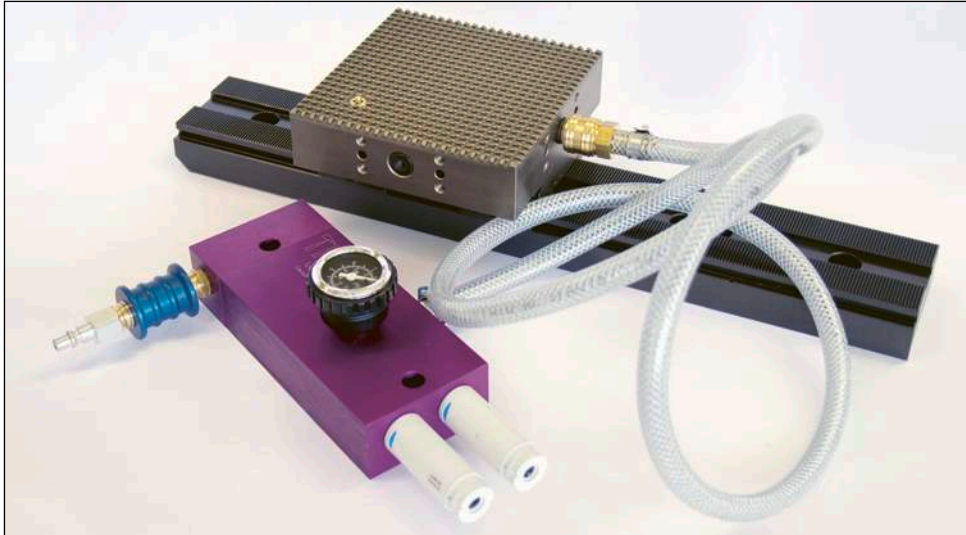

Bei der Spannung mit Vakuum wird der Druck nicht mechanisch auf das Werkstück sondern durch die umgebende Atmosphäre ausgeübt. Dadurch werden die Werkstücke schonend und gleichmässig über die ganze Auflagefläche fixiert, so dass kaum Vibrationen entstehen.

Der Beschickungs- und Arbeitsraum bleibt zudem frei von Briden und Spannmittel.

► **Diese Spannmethode ist vor allem für grossflächige, dünnwandige, auch nichtmagnetische Werkstücke geeignet.**

Triva Clamp besteht aus folgenden Funktionsteilen:

- **Vakuumpplatten** mit passenden Anschlagleisten für den Einsatz mit seitlich einwirkenden Kräften.
- **Dichtschnur aus Silikongummi**, die immer entlang der Peripherie des Werkstücks eingelegt wird. Die Haltekraft wächst proportional zur Aufspannfläche, die durch die Dichtschnur begrenzt wird.
- **Rotations-Vakuumpumpe** mit Schaltventil und Druckwächter optional.
- **Injektorpumpe** mit Schaltventil.

Die Ansaugbohrungen werden mit Hilfe von **Triva Clamp-Ventilen** versiegelt. Wenn die Ventile geschlossen sind, sind keine Löcher in der Platte vorhanden, so dass kaum Kühlflüssigkeit eindringen kann. Das **Triva Clamp-Ventil** wird bei der Auflage des Werkstückes automatisch aktiviert. Ständiges manuelles Öffnen und Verschliessen der Bohrungen entfällt somit.

In vacuum clamping the clamping force is not applied to the work piece mechanically, but is provided by the surrounding atmosphere. This means that the work piece is gently and evenly pulled down over the whole supporting surface, so that vibration is minimized. As there are no obstructing brackets, clamps or workholding modules in the working and loading area, there are fewer chances for collisions with the tool.

► **This clamping method is particularly suitable for large surface, thin-walled and also non magnetic work pieces.**

Triva Clamp consists of the following functional devices:

- **Vacuum plates** with suitable stop gauges for application with lateral workholding forces.
- **Silicone-rubber sealing cord** inlaid along the periphery of the work piece. The clamping force increases proportionally to the surface area defined by the sealing cord.
- **Rotary vacuum pump** with control unit and pressure sensor.
- **Injector pump** with control unit.

*The suction holes are sealed by the **Triva Clamp valves**. With these valves closed there are no holes in the plate so that hardly any coolant can enter. The **Triva Clamp valve** is automatically activated by placing the work piece on the vacuum plate. Hence constant opening and closing of the suction holes is omitted.*

Theoretische Haltekraft:

Unter Einbezug eines Sicherheitsfaktors für atmosphärische Druckschwankungen und Leckagen im Vakuumkreislauf rechnen wir mit einem zur Verfügung stehenden Druck von 0,85 bar Vakuum oder 8,5 N/cm² (wobei der Druck von der Höhe über Meer abhängig ist).

Diesen Druck bezeichnen wir als theoretisch 100%. Bei 300 cm² Spannfläche ergibt sich also eine theoretische Spann-/Haltekraft von 8,5 N/cm² x 300 cm² = 2550N.

Diese theoretische Haltekraft basiert auf einem vollständigen Hohlraum unter dem Werkstück. Dies ist in der Praxis jedoch nicht möglich, weil das Werkstück abgestützt werden muss.

Effektive Haltekraft:

Das heisst, je grösser der Hohlraum unter dem Werkstück und je geringer die Auflagefläche für das Werkstück, desto grösser sind die Haltekräfte.

Die effektive Haltekraft ist folglich abhängig vom Wirkungsgrad des Vakuumspannsystems.

Vakuumspannsysteme im Vergleich:

Lochplatte Plate with suction holes

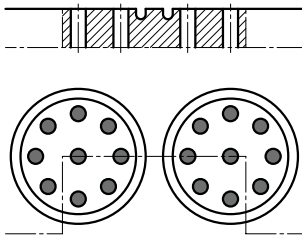

Pro Element Ø 40 mm
9 Bohrungen Ø 4 mm.
Each section of Ø 40 mm
having 9 bores of Ø 4 mm.

Wirkungsgrad: 9%
Degree of efficiency: 9%

Schlitzplatte Plate with slots

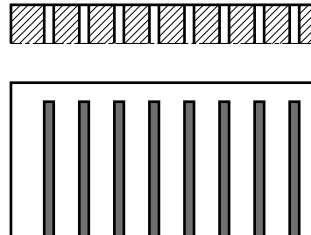

Steg 8 mm, Schlitz 2 mm
Slots 2 mm, bar 8 mm

Wirkungsgrad: 25%
Degree of efficiency: 25%

Theoretical holding force:

Including a safety factor for atmospheric pressure variations and leaks within the vacuum circuit, we calculate an available pressure of 0,85 bar (12,1psi) vacuum equalling 8,5 N/cm² (whereas pressure is dependent on altitude).

This amount of pressure is referred to as theoretically attainable 100%. For 300 cm² /46,5 sq inch the pressure thus is 8,5 N/cm² x 300 cm² = 2550N (12,1psi x 46,5sq in = 562lbs).

This theoretically calculated holding force is based upon a hollow space underneath the entire work piece. This is not possible because the work piece must be supported. Therefore we have to subtract the area supporting the workpiece.

Effective holding force:

In other words: the larger the work piece supporting area, thus reducing the hollow space representing the holding area, the lesser the holding force.

Consequently, the effective holding force depends entirely upon the rate of efficiency of the vacuum system.

Comparison of various vacuum systems:

Nutenplatte Plate with U-shaped grooves

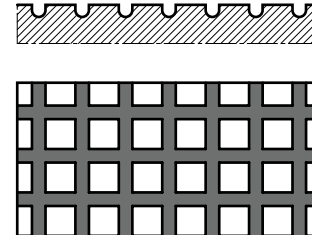

Raster 10x10 mm, Nute 3 mm
Grid 10x10 mm, grooves 3 mm

Wirkungsgrad: 51%
Degree of efficiency: 51%

Triva Clamp Waffelmuster Triva Clamp waffle pattern

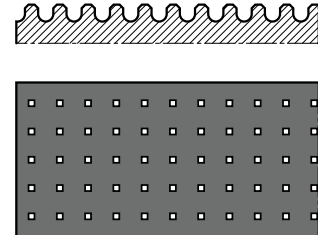

Raster 6,5 mm, Nute 5 mm
Grid 6,5 mm, grooves 5 mm

Wirkungsgrad: 92%
Degree of efficiency: 92%

Besonderheiten von Triva Clamp:

Durch die besondere Formgebung der Werkstückauflage (Waffelmuster) erreicht Triva Clamp einen kaum zu übertreffenden **Wirkungsgrad von theoretisch 92% = 2346 N bei einem maximal erreichbaren Wert von 2550 N (bezogen auf 300 cm² Spannfläche).**

Toleranzen

Höhe 40 mm ± 0,02 / 400 mm
Ebenheit über alles: ± 0,03 / 400 mm

Special features Triva Clamp:

The unique shape of the Triva Clamp workpiece supporting area (waffle pattern) guarantees maximum attainable holding force with a rate of **efficiency of theoretically 92%, equalling 2346 N holding force applied to the work piece of 300cm² (46,5sq in) holding surface.**

Tolerances

Height 40 mm ± 0,02 / 400 mm
Flatness all over: ± 0,03 / 400 mm

Alle Vakuumplatten sind aus hochfestem Aluminium hergestellt und für eine lange Lebensdauer **Hartanodisiert** beschichtet. Durch an jeder Seite angebrachte Koppelbohrungen wird es möglich, die Spannfläche nach Bedarf allseitig zu erweitern.

Vacuum plates are made from high tensile aluminum alloy, are **hard anodized** treated for long tool life. Triva plates can be coupled longitudinally and transversely with any holding plate to suit workpieces, limited by machine table size only.

Mechanische Spannung = Druck auf das Werkstück, daraus resultieren:

- Belastung des Werkstücks
- Druckmarken in weichen Werkstoffen
- Verformung labiler Teile
- Risiko von Vibrationen

Mechanical clamping = pressure applied to workpiece, result:

- Stress applied to workpiece
- Pressure marks in soft materials
- Deforming of delicate workpieces
- Risk of vibrations

Vakuumspeisung = Druck auf Spannplatte

Durch die umgebende Atmosphäre, daraus folgt:

- Schonende, gleichmässige Fixierung jeglicher Werkstoffe über die ganze Auflagefläche
- Keine Vibrationen
- Freier Bestückungs- und freier Arbeitsraum

Vacuum clamping = pressure upon vacuum-plate

By the surrounding atmosphere, resulting in:

- Equal distribution of holding force over the Entire workpiece holding surface
- Machining with no risk of vibrations
- Free, clear loading and processing area

Spannen von Platten mit Klemm-Briden

Haltekräft nur am Rand. Vibrationen in Werkstückmitte. Folgeoperationen notwendig.

Clamping of plates, using clamps

Edges fixed only - Vibrations in center of workpiece - Subsequent operations required.

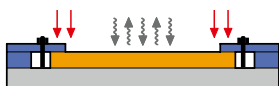

Spannen von unförmigen Werkstücken

Für Werkstücke mit unförmigen Konturen und Durchgangsbohrungen stellen wir Spezialvorrichtungen her.

Holding of bulky workpieces

We build special devices for workpieces with bulky outlines and through bore-holes.

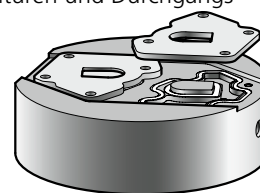

Spannen von Platten mit Tiefspannbacken

Haltekräft nur am Rand, Vibrationen in Werkstückmitte. Hoher Spanndruck erzeugt Spannung und Verformung.

Clamping of plates, using clamping jaws

Also high pressure applied to workpiece, holding effect at the edges - Risk of deformation and vibrations.

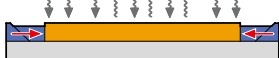

Spannen von Platten auf Vakuum-Platte

Haltekräft gleichmässig über ganze Auflagefläche verteilt. Keine Vibrationen - Freier Arbeitsraum.

Holding of plates, using vacuum-plate

Holding force equally spread all over the workpiece holding area - No vibrations - Free processing area.

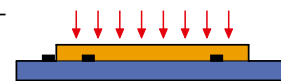

Kubus spannen im Schraubstock

Belastung des Werkstücks - Risiko von Druckmarken.

Clamping of cubic-shaped items, using vise

Stress applied - Risk of pressure marks in workpiece.



Kubisches Werkstück spannen mit Vakuum-Platte und Steilwänden

Werkstück an 3 (bis 5) Seiten ohne mechanischen Druck gehalten.

Holding of cubic-shaped item, using vacuum-plate and vertical walls

Workpiece held from 3 (up to 5) directions. No stress applied - No stress applied - No pressure marks.

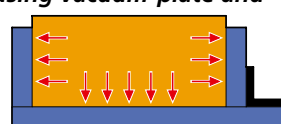

Spannen von U-Profilen im Schraubstock

Risiko von Deformationen und Vibrationen.

Clamping of U-profile, using vise

Risk of deformation and vibrations during processing.

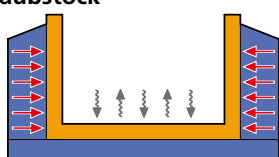

Spannen von U-Profilen mit Vakuum-Platte und Steilwänden

Allseitig gleichmässige, druckfreie Aufspannung. Bearbeitung ohne Risiko von Vibrationen.

Holding of U-profile, using vacuum-plate and 2 vertical walls

Uniform, stressfree holding from 3 directions - No risk of deformations or vibrations during processing.

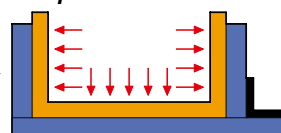

Spannen von Winkelprofil mit Briden

Umständliches Bestücken und Bearbeiten sowie grosse Vibrationen.

Clamping of angled workpiece, using clamps

Bothersome clamps, vibrations, subsequent operation.

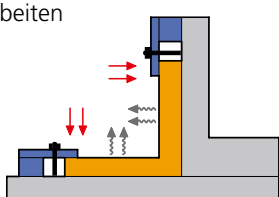

Spannen von Winkelprofil mit Vakuum-Platte und 1 Steilwand

Gleichmässig verteilte Haltekräft. Leichtes Bestücken und freier Arbeitsraum. Keine Vibrationen, keine Nacharbeit notwendig.

Holding of angled workpiece, using vacuum-plate and 1 vertical wall

Uniform stressfree holding - No risk of vibrations - No clamps, free, clear work area for easier, faster loading and processing.

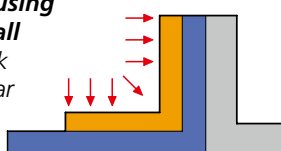

Rote Pfeile → zeigen die Spannrichtung, graue Pfeile ~→ zeigen Vibrationskräfte
Red arrows → show the holding force direction, gray arrows ~→ show vibration forces

Vakuumplatte auf Maschinentisch befestigen / Mounting vacuum plate on machine table

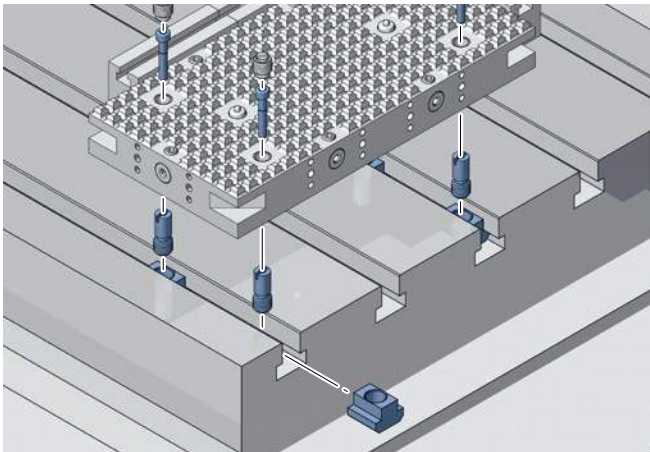

Mechanisch befestigt / Mechanical mounting

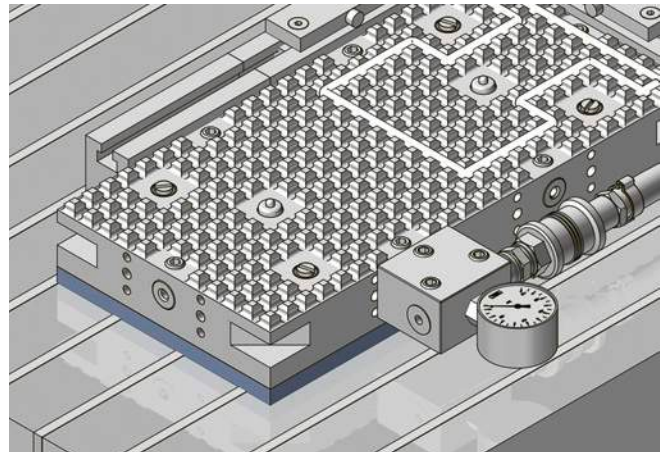

Magnetisch befestigt / Magnetical mounting

Platten koppeln / Connect plates

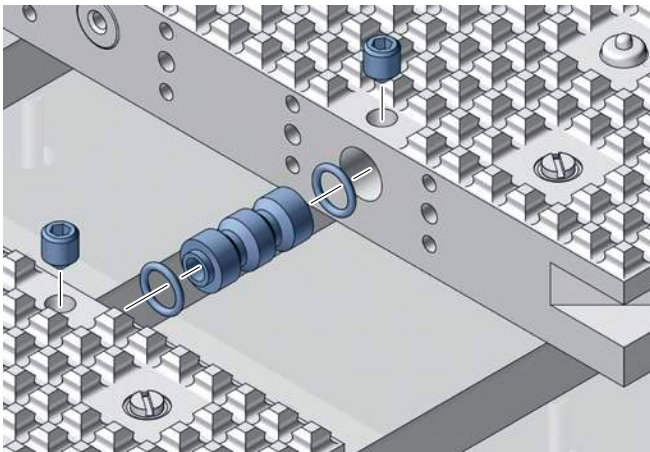

Mit Vakuumverbinder / With vacuum circuit connector

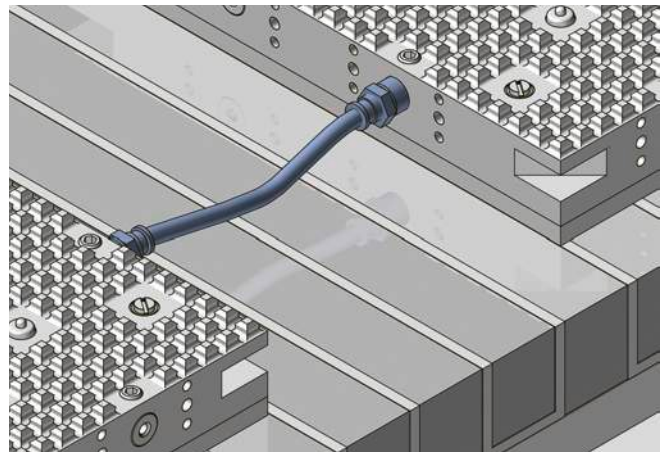

Mit Verbindungsschlauch / With connector-tube

Mit Pumpe verbinden / Connect to pump

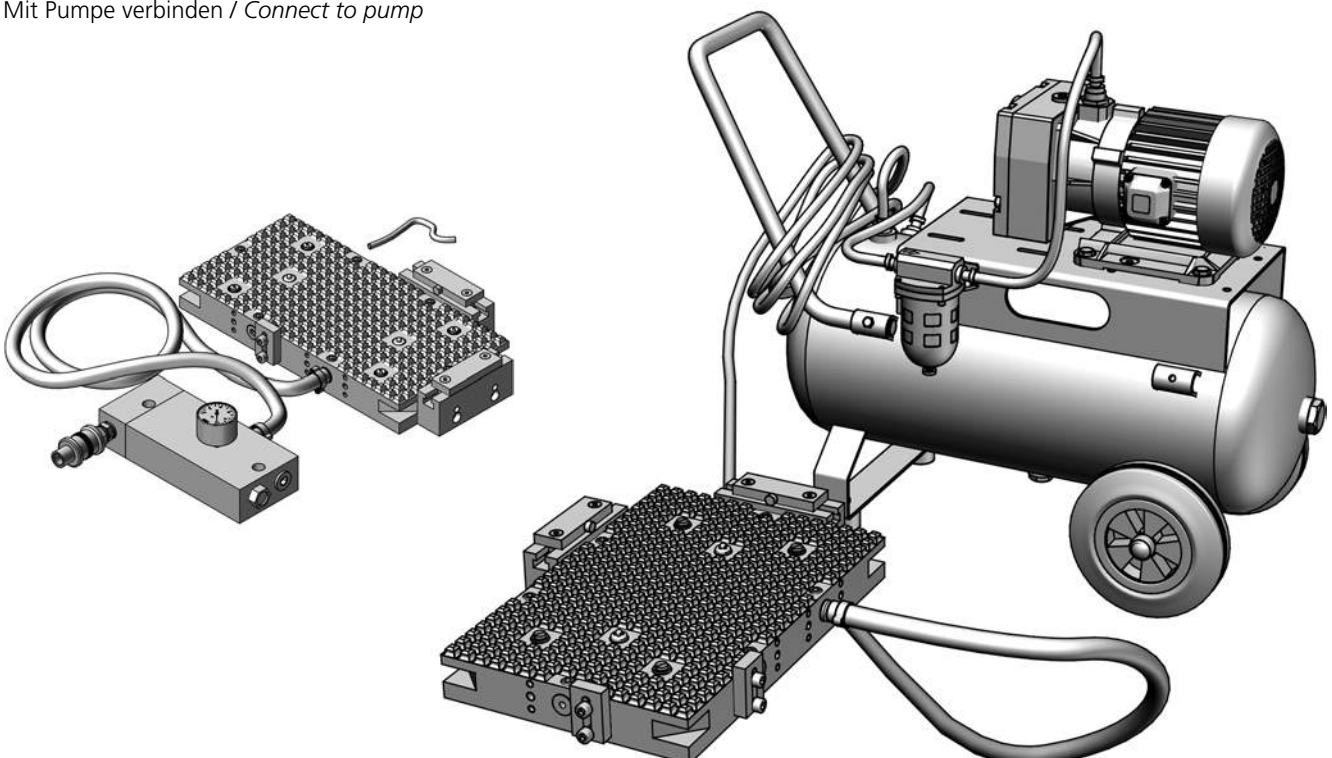

Dichtsnur und Werkstück einlegen / Insert sealing cord and workpiece

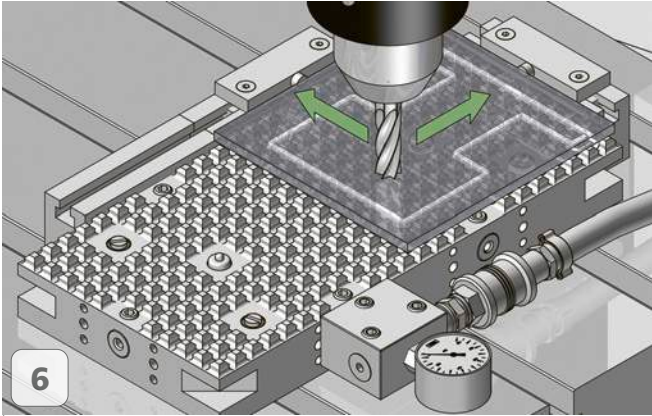
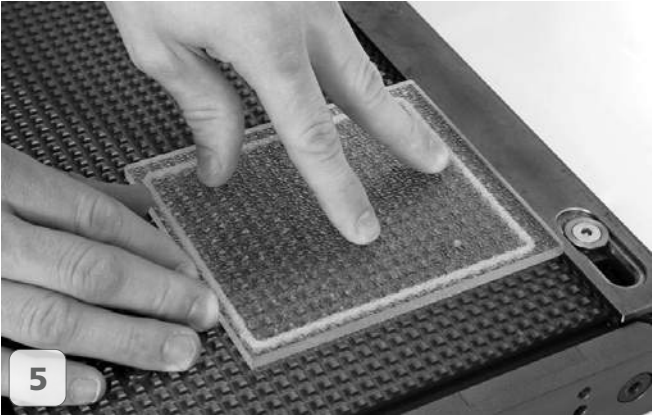
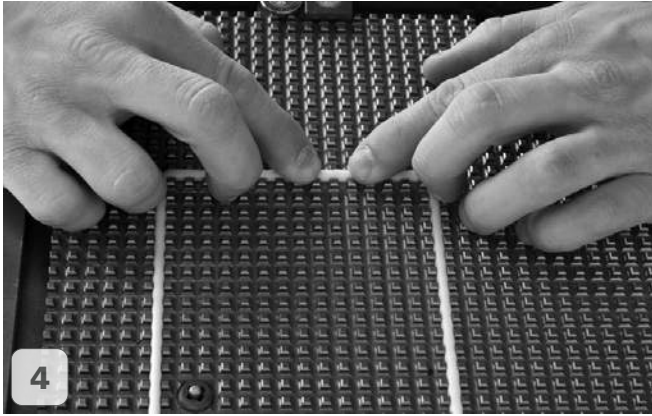
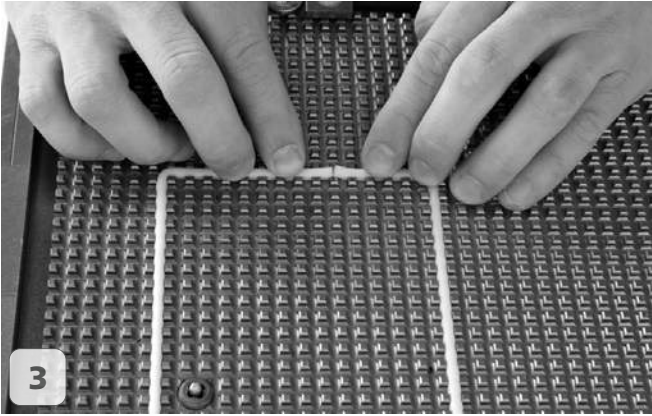
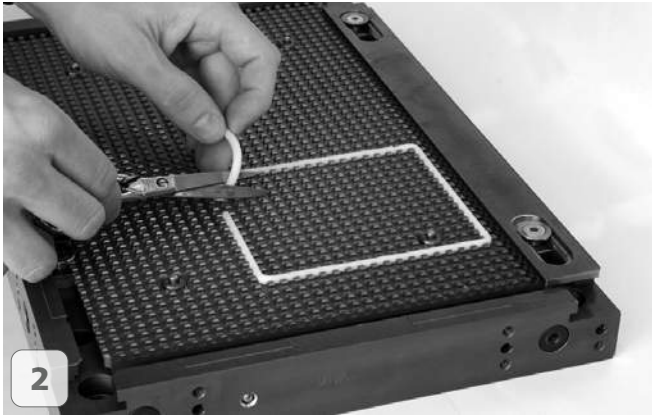
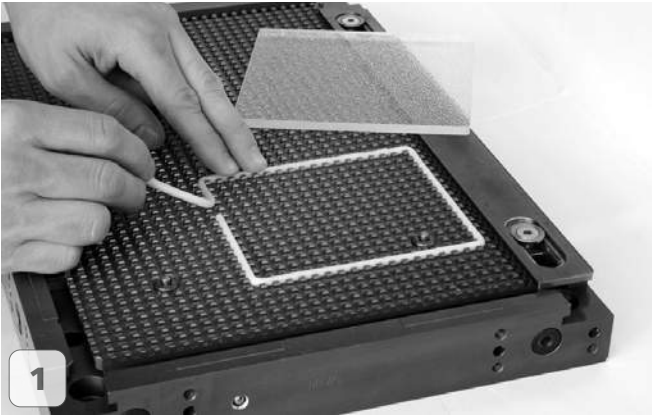

Fräsrichtung beachten:
wenn möglich, gegen Festanschläge fräsen.
Pay attention to machining direction:
if possible, toward stop gages milling.

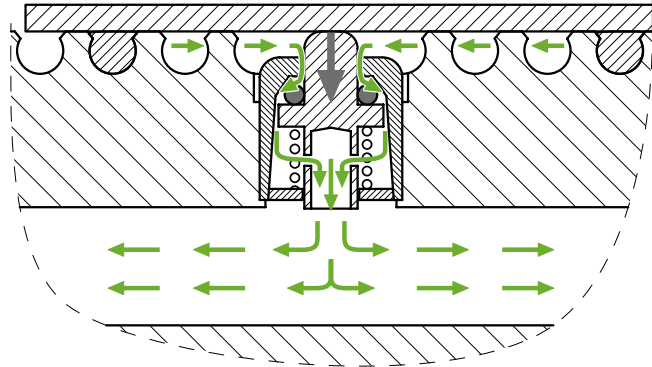
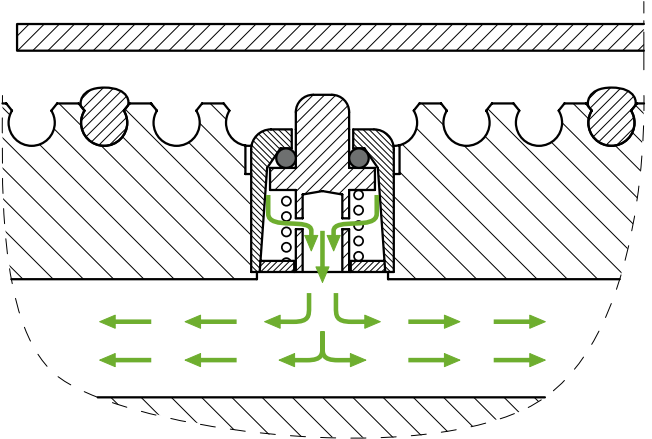



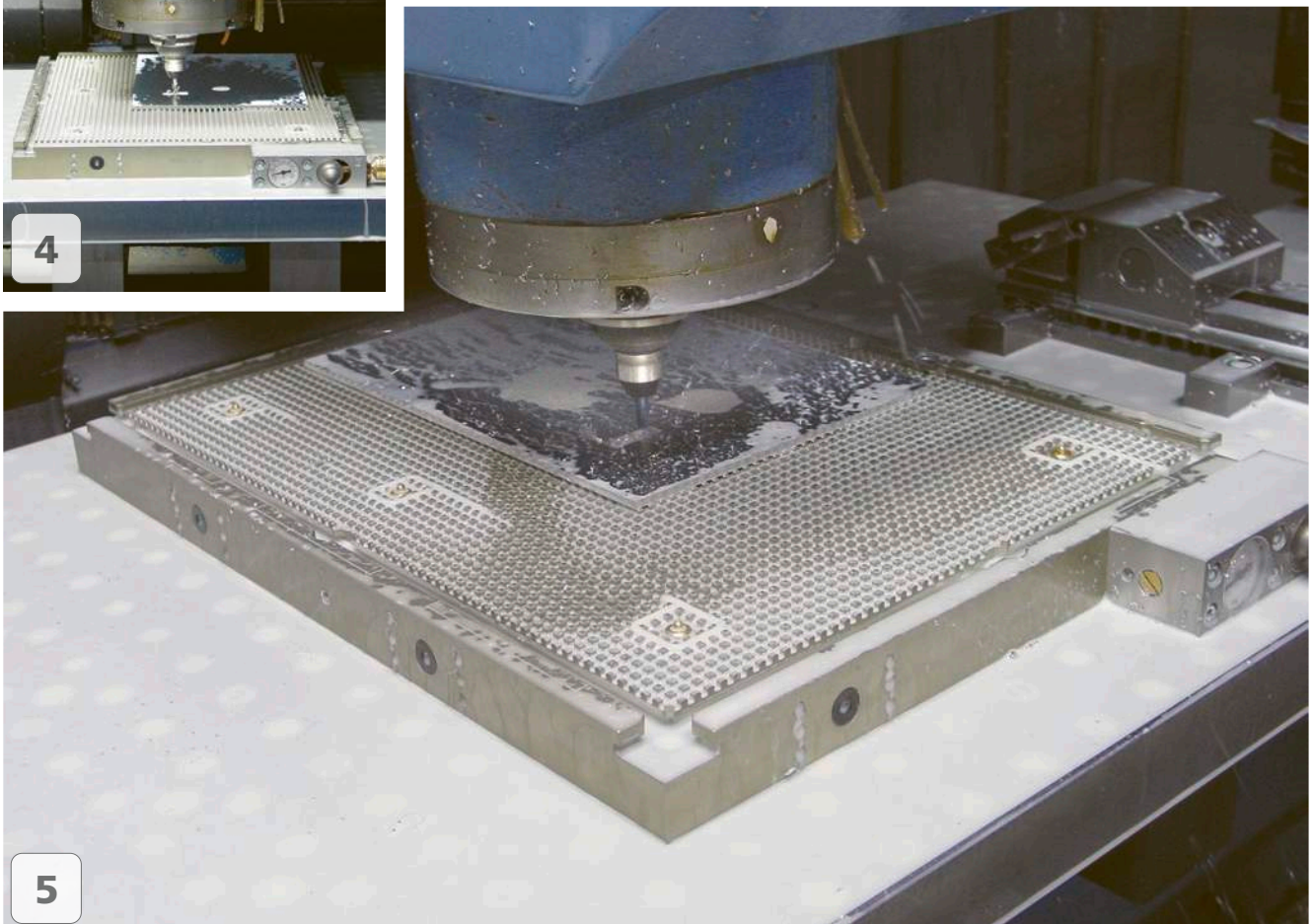
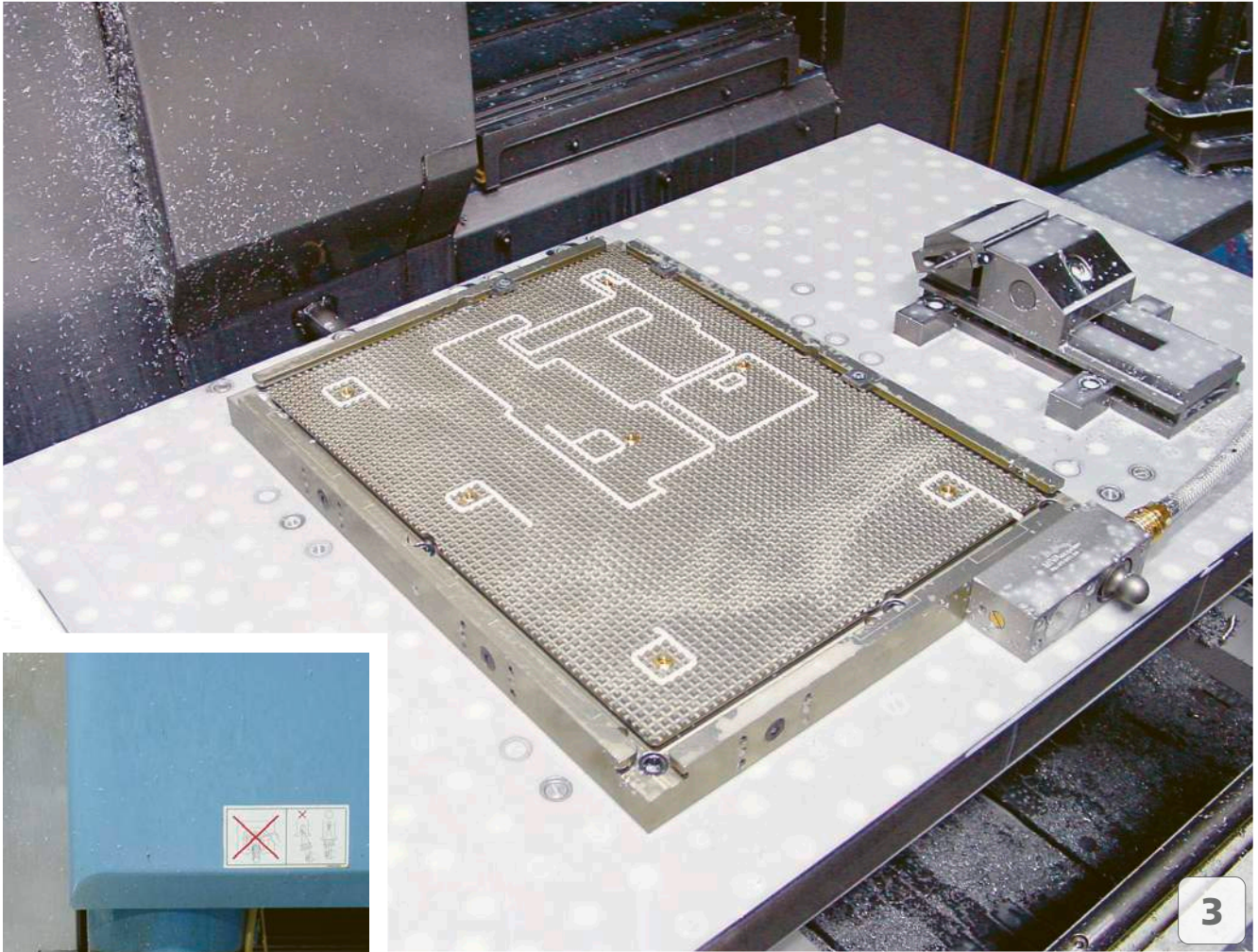

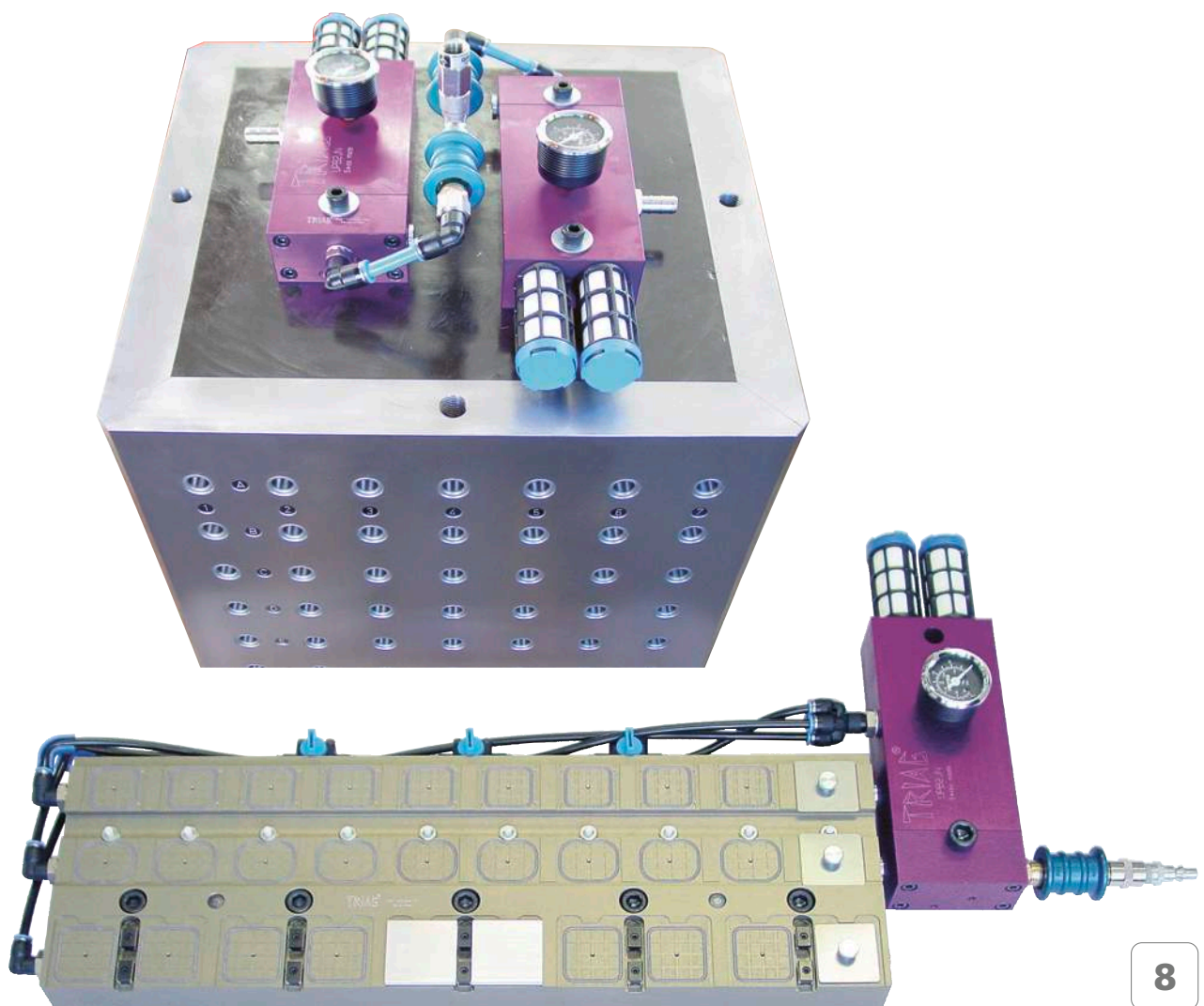

Bestellschlüssel Vakuumplatten

Order code vacuum plates

trivaCLAMP

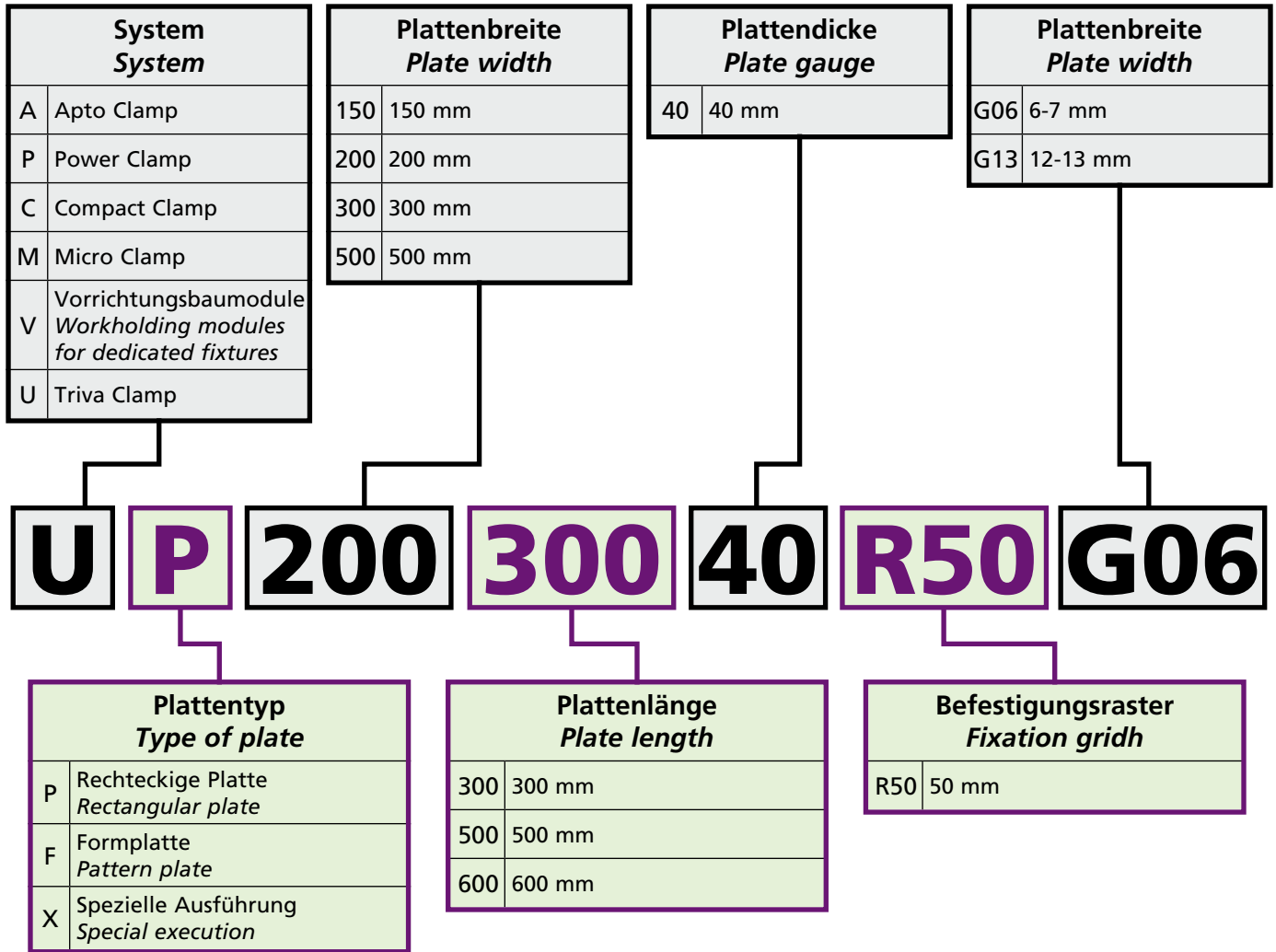

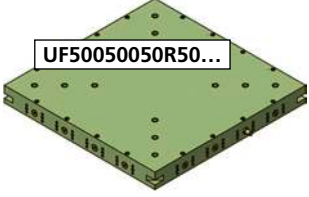

UF50050050R50...

Formplatten

Für spezielle Werkstücke, die für das Spannen auf den Standardplatten ungeeignet sind, haben wir Rohplatten entwickelt, die bis zu 3 mal überfräst werden können. So lassen sich bis zu 3 verschiedene Werkstücke nacheinander bearbeiten.

Die plates

For special work pieces that are unsuitable for clamping on the standard plates, we have developed raw plates that can be milled again up to 3 times. This way, up to 3 different work pieces can be machined one after the other.

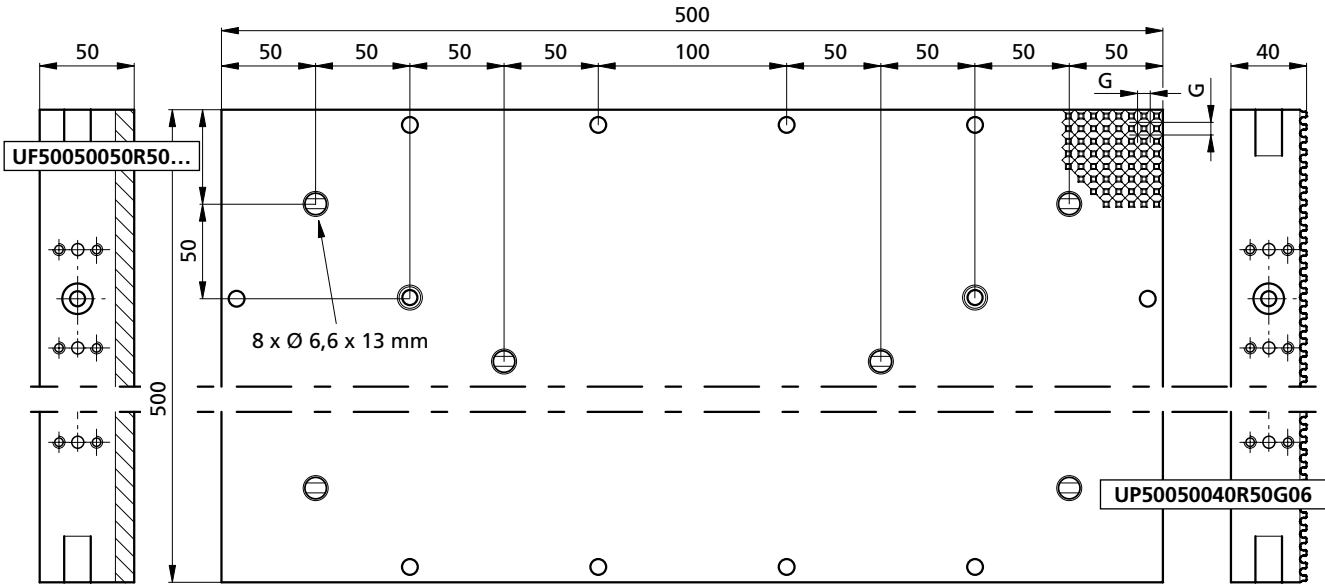

- G13**
- UP50050040R50G13**
- ① 1x TH160150
 - ② 4x 0700100
 - ③ 1x 1110100
 - ④ 15x 0920000
 - ⑤ 16x 1111003
 - ⑥ 16x M10X12ISO4027
 - ⑦ 8x M6X45ISO4762
 - ⑧ 1x 0910001
 - ⑨ 8x 0700102
- G = 12,5 mm
kg ~24

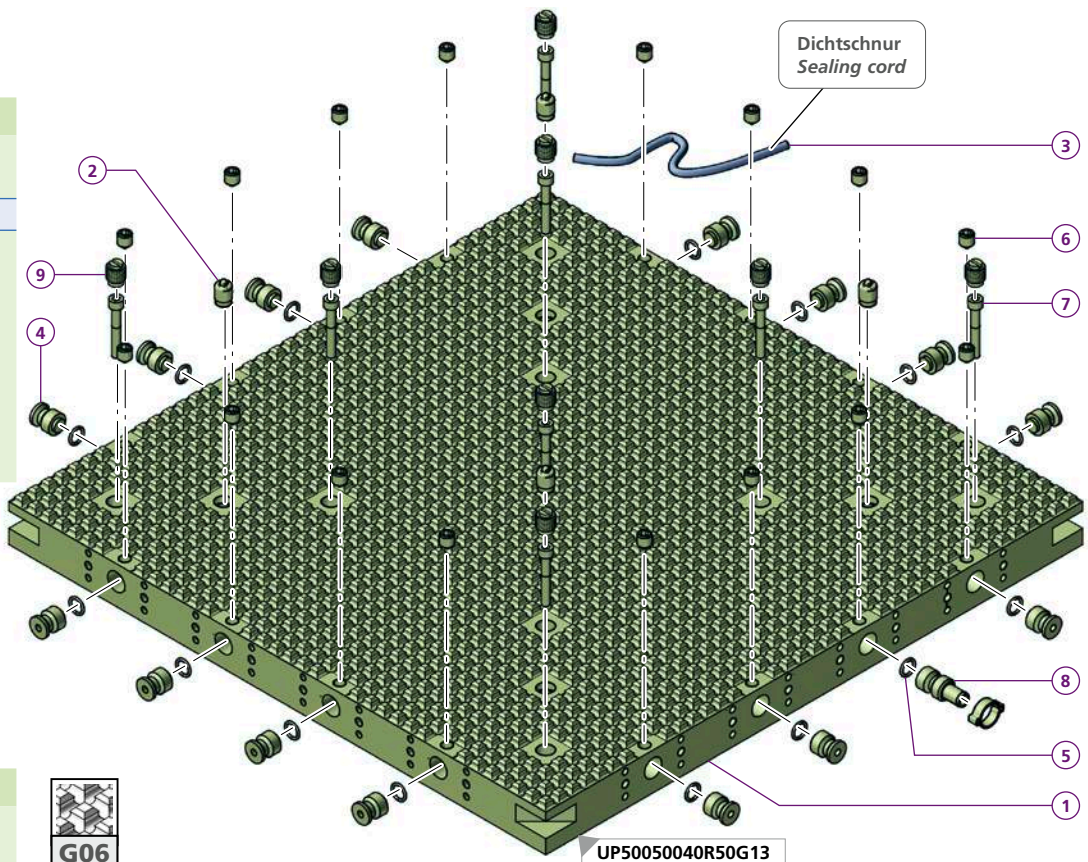

- UF50050050R50...**
- ① 1x TH160151
 - ② 4x 0700100
 - ③ 1x
 - ④ 15x 0920000
 - ⑤ 16x 1111003
 - ⑥ 16x M10X12ISO4027
 - ⑦ 8x M6X45ISO4762
 - ⑧ 1x 0910001
 - ⑨ 8x 0700102
- kg ~32,5

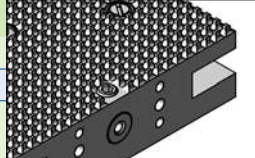
- G06**
- UP50050040R50G06**
- ① 1x TB160159
 - ③ 1x 1120100
- G = 6,5 mm
kg ~26
- 

Profilfräser / Carbide end mills G13 / G06 p. 324

Dichtschnüre je nach Bedarf / Sealing cords as needed

Bestellbeispiel / Ordering example:
UP50050040R50G13 & 1x 1110100

Separat bestellen / Order separately

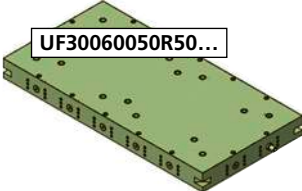

UF30060050R50...

Formplatten

Für spezielle Werkstücke, die für das Spannen auf den Standardplatten ungeeignet sind, haben wir Rohplatten entwickelt, die bis zu 3 mal überfräst werden können. So lassen sich bis zu 3 verschiedene Werkstücke nacheinander bearbeiten.

Die plates

For special work pieces that are unsuitable for clamping on the standard plates, we have developed raw plates that can be milled again up to 3 times. This way, up to 3 different work pieces can be machined one after the other.

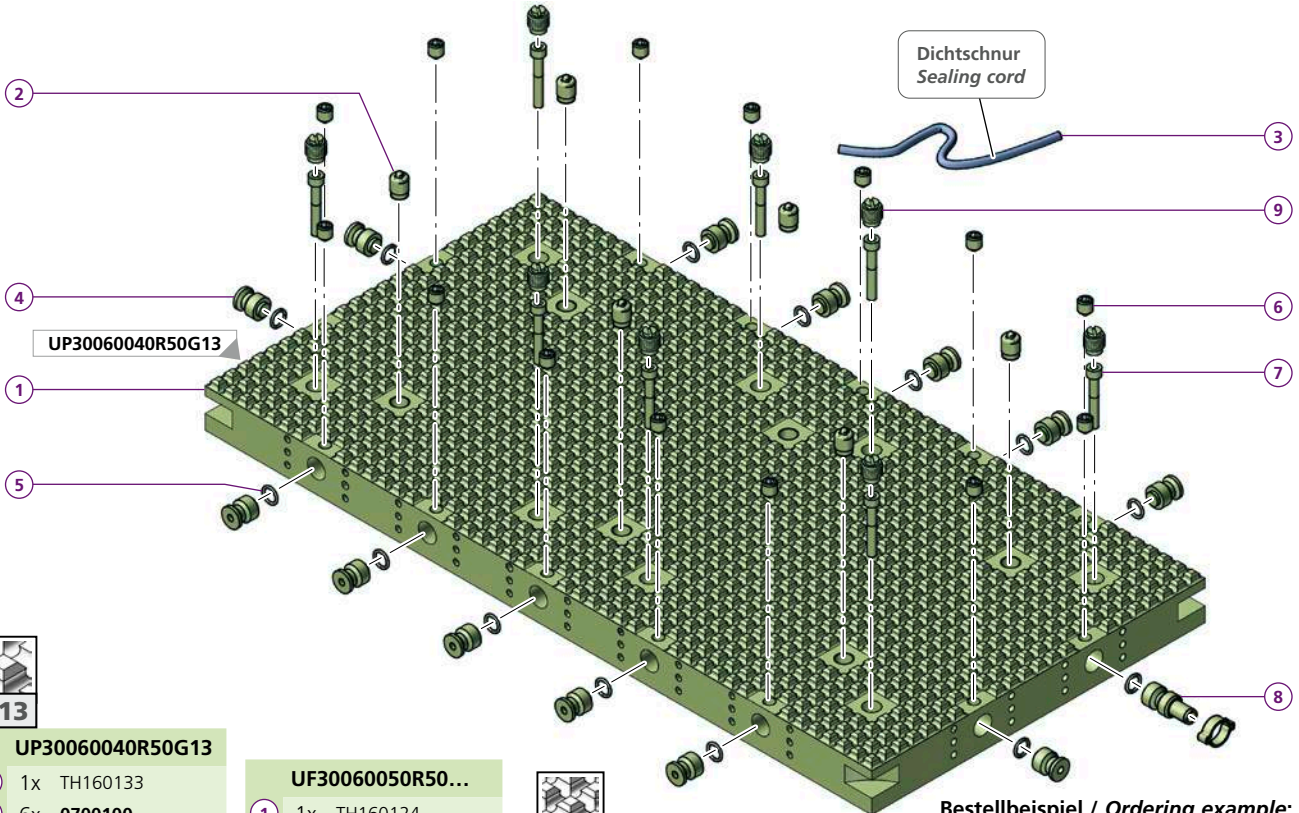
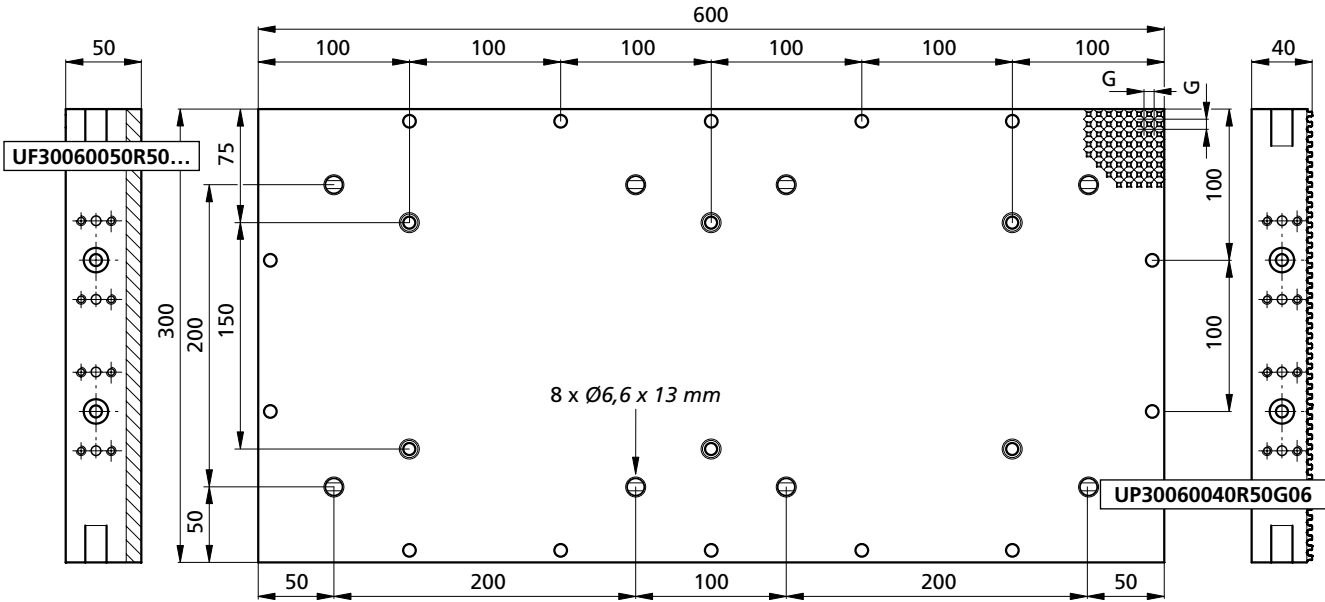

UP30060040R50G13	
1	1x TH160133
2	6x 0700100
3	1x 1110100
4	13x 0920000
5	13x 1111003
6	14x M10X12ISO4027
7	8x M6X45ISO4762
8	1x 0910001
9	8x 0700102
G	= 12,5 mm
kg	~18

UF30060050R50...	
1	1x TH160124
2	6x 0700100
3	1x
4	13x 0920000
5	13x 1111003
6	14x M10X12ISO4027
7	8x M6X45ISO4762
8	1x 0910001
9	8x 0700102
kg	~24,36



UP30060040R50G06	
1	1x TH120176
3	1x 1120100
G	= 6,5 mm
kg	~18,5

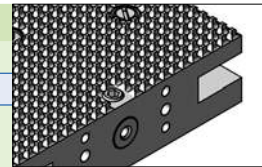

Bestellbeispiel / Ordering example:
UP30060040R50G13 & 1x 1110100

Profilfräser / Carbide end mills G13 / G06 p. 324

Dichtsnüre je nach Bedarf / Sealing cords as needed

Separat bestellen / Order separately

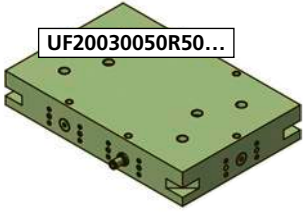

Formplatten
 Für spezielle Werkstücke, die für das Spannen auf den Standardplatten ungeeignet sind, haben wir Rohplatten entwickelt, die bis zu 3 mal überfräst werden können. So lassen sich bis zu 3 verschiedene Werkstücke nacheinander bearbeiten.

Die plates
 For special work pieces that are unsuitable for clamping on the standard plates, we have developed raw plates that can be milled again up to 3 times. This way, up to 3 different work pieces can be machined one after the other.

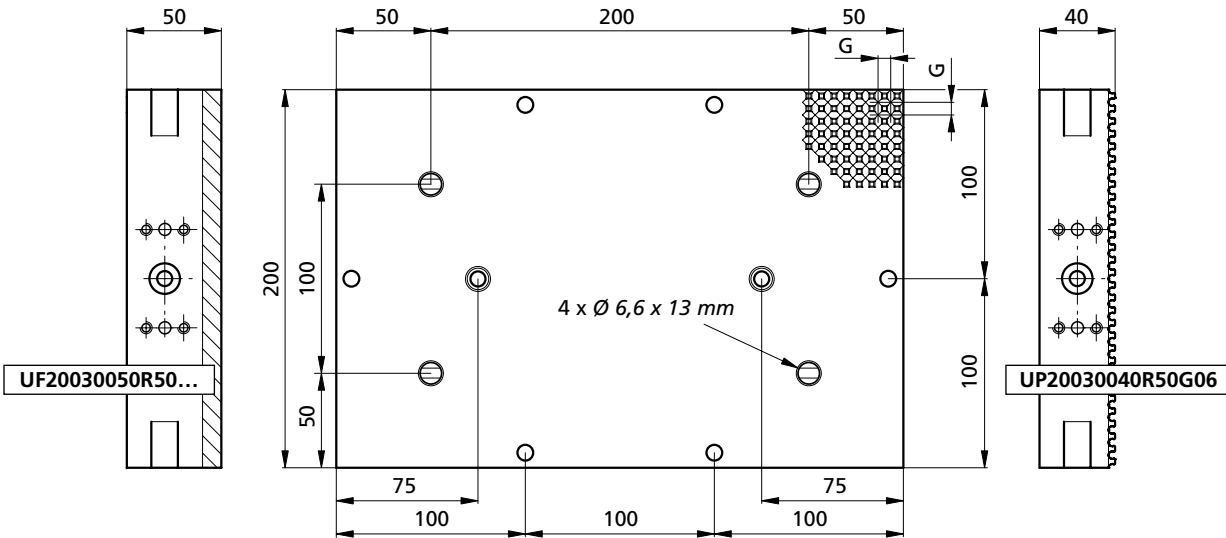

G13

UP20030040R50G13

1	1x TH160135
2	2x 0700100
3	1x 1110100
4	5x 0920000
5	6x 1111003
6	6x M10X12ISO4027
7	4x M6X45ISO4762
8	1x 0910001
9	4x 0700102
G	= 12,5 mm
kg	~5,5

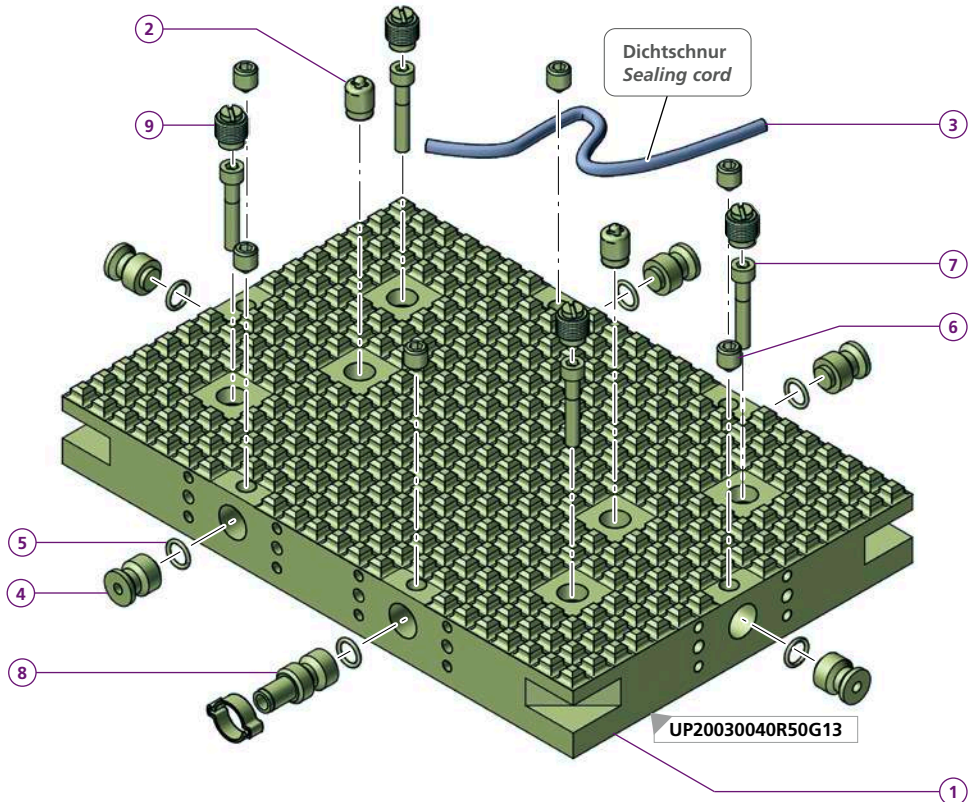

G06

UP20030040R50G06

1	1x TH120175
3	1x 1120100
G	= 6,5 mm
kg	~6,0

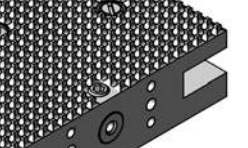

UF20030050R50...

1	1x TH160136
2	2x 0700100
3	1x
4	5x 0920000
5	6x 1111003
6	6x M10X12ISO4027
7	4x M6X45ISO4762
8	1x 0910001
9	4x 0700102
kg	~8,09

Bestellbeispiel / Ordering example:
UP20030040R50G13 & 1x 1110100

Profilfräser / Carbide end mills G13 / G06 p. 324

Dichtschnüre je nach Bedarf / Sealing cords as needed

Separat bestellen / Order separately



Formplatten
Für spezielle Werkstücke, die für das Spannen auf den Standardplatten ungeeignet sind, haben wir Rohplatten entwickelt, die bis zu 3 mal überfräst werden können. So lassen sich bis zu 3 verschiedene Werkstücke nacheinander bearbeiten.

Die plates
For special work pieces that are unsuitable for clamping on the standard plates, we have developed raw plates that can be milled again up to 3 times. This way, up to 3 different work pieces can be machined one after the other.

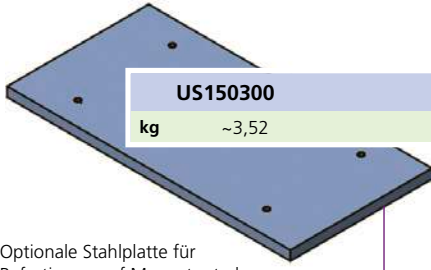
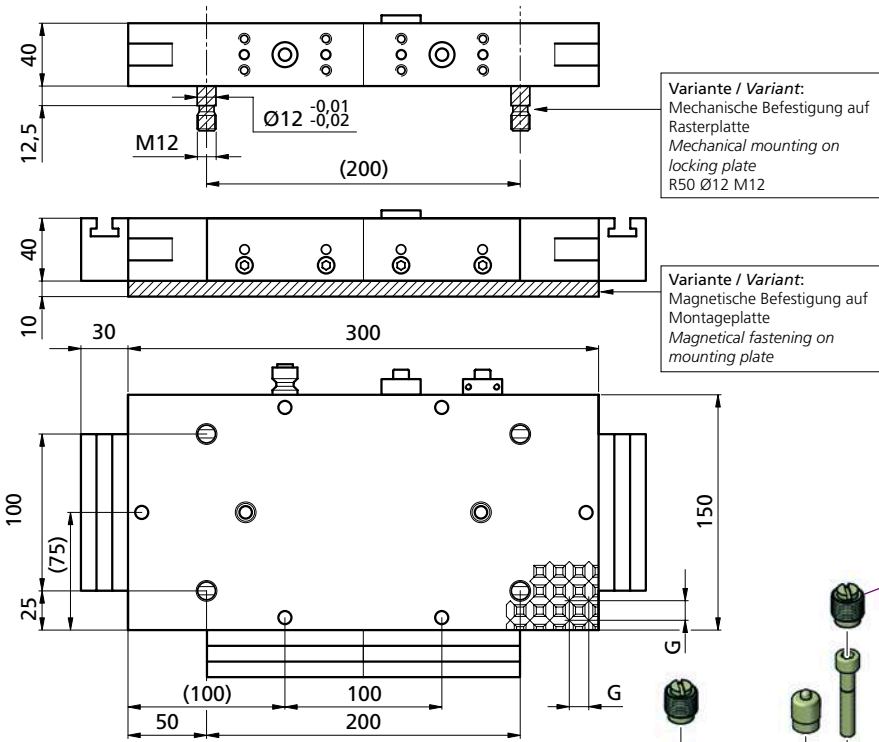

G13

UP15030040R50G13

1	1x TH150942
2	2x 0700100
3	1x 1110100
4	5x 0920000
5	6x 1111003
6	6x M10X12ISO4027
7	4x M6X35ISO4762
8	1x 0910001
9	4x 0700102
10	4x ADAPT6-12

G = 12,5 mm
kg ~4,6

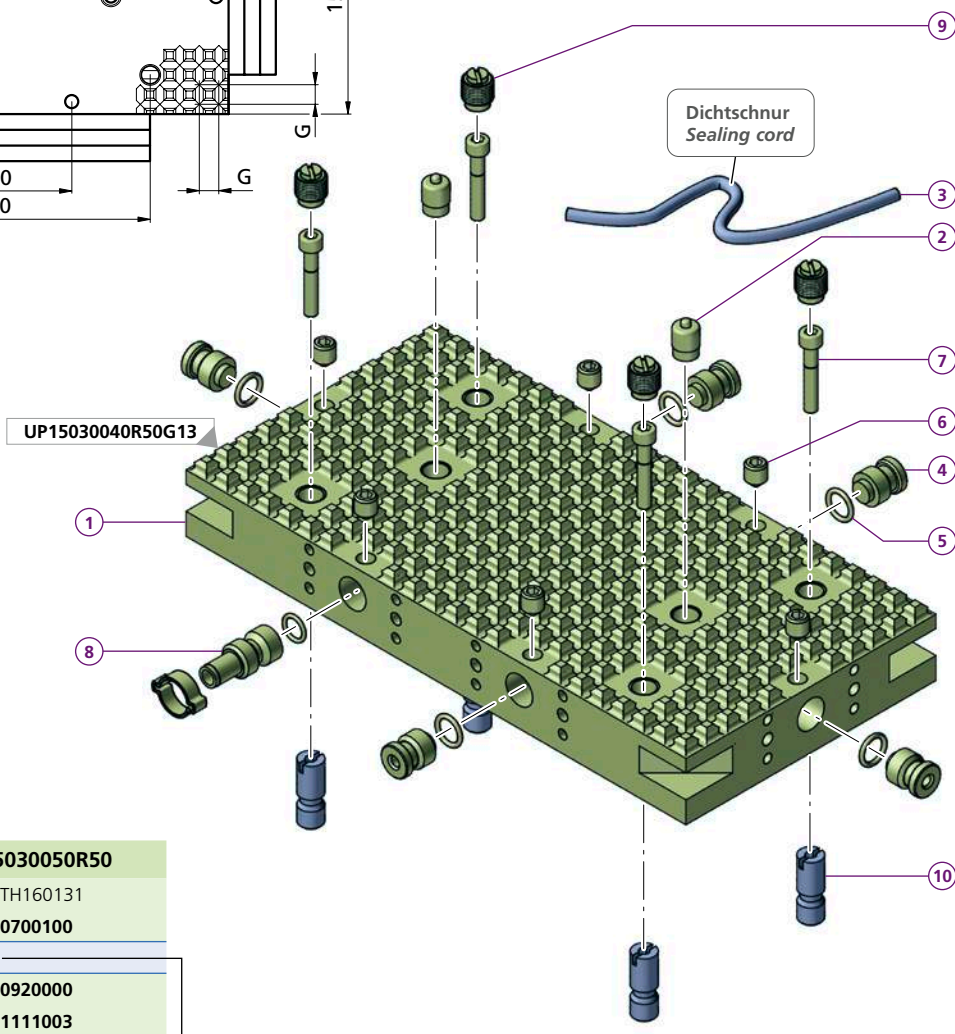

G06

UP15030040R50G06

1	1x TH160132
3	1x 1120100

G = 6,5 mm
kg ~4,8

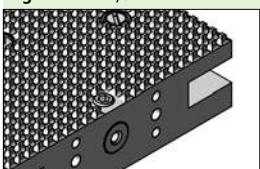

UF15030050R50

1	1x TH160131
2	2x 0700100
3	1x
4	5x 0920000
5	6x 1111003
6	6x M10X12ISO4027
7	4x M6X35ISO4762
8	1x 0910001
9	4x 0700102

kg ~6

Bestellbeispiel / Ordering example:
UP15030040R50G13 & 1x ADAPT6-12 & 1x 1110100

Profilfräser / Carbide end mills G13 / G06 p. 324
Dichtschnüre je nach Bedarf / Sealing cords as needed

Separat bestellen / Order separately

Vakuum-Modul für powerCLAMP Vacuum module for powerCLAMP

PS1X150L60-VAC *trivaCLAMP*

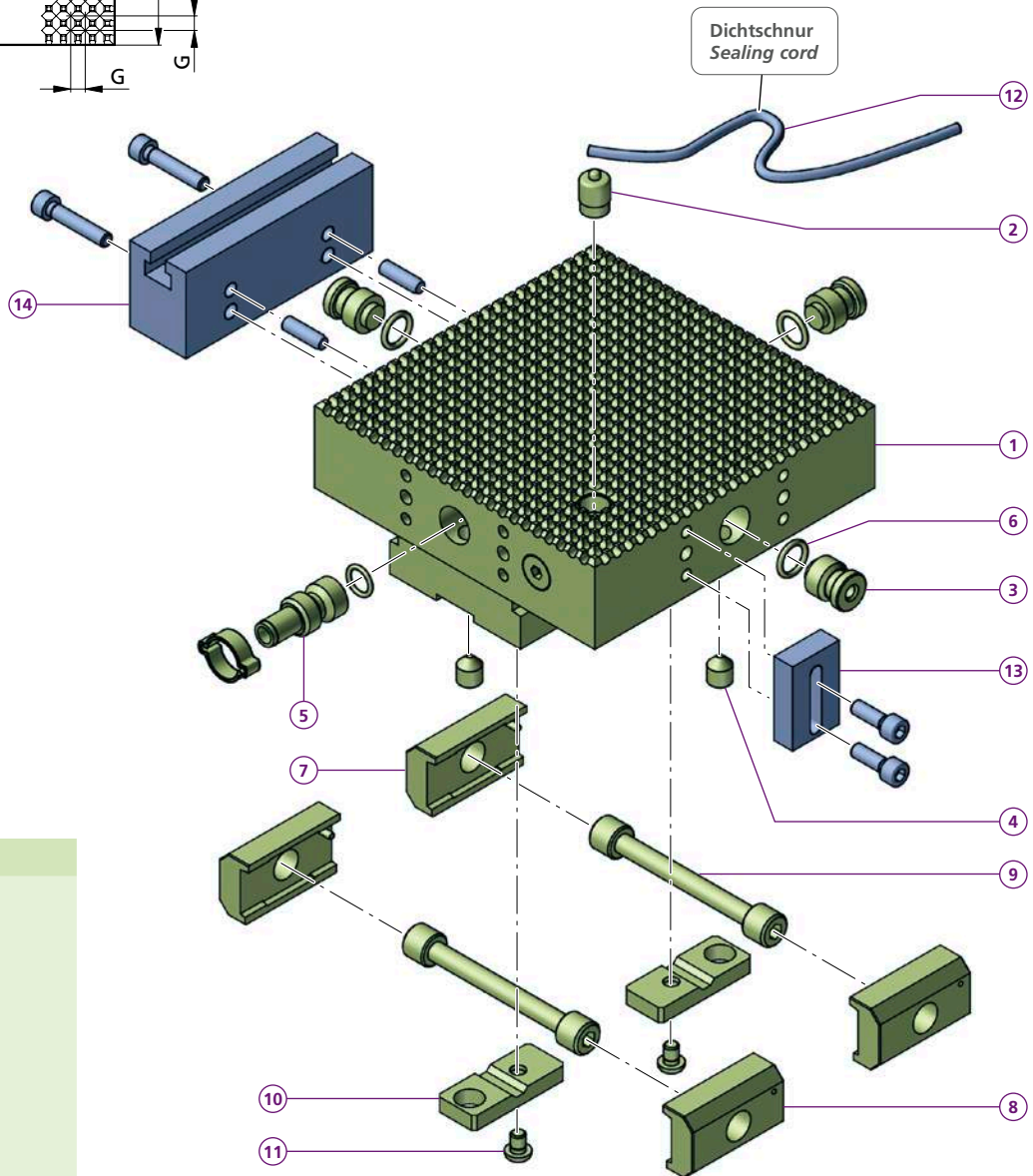
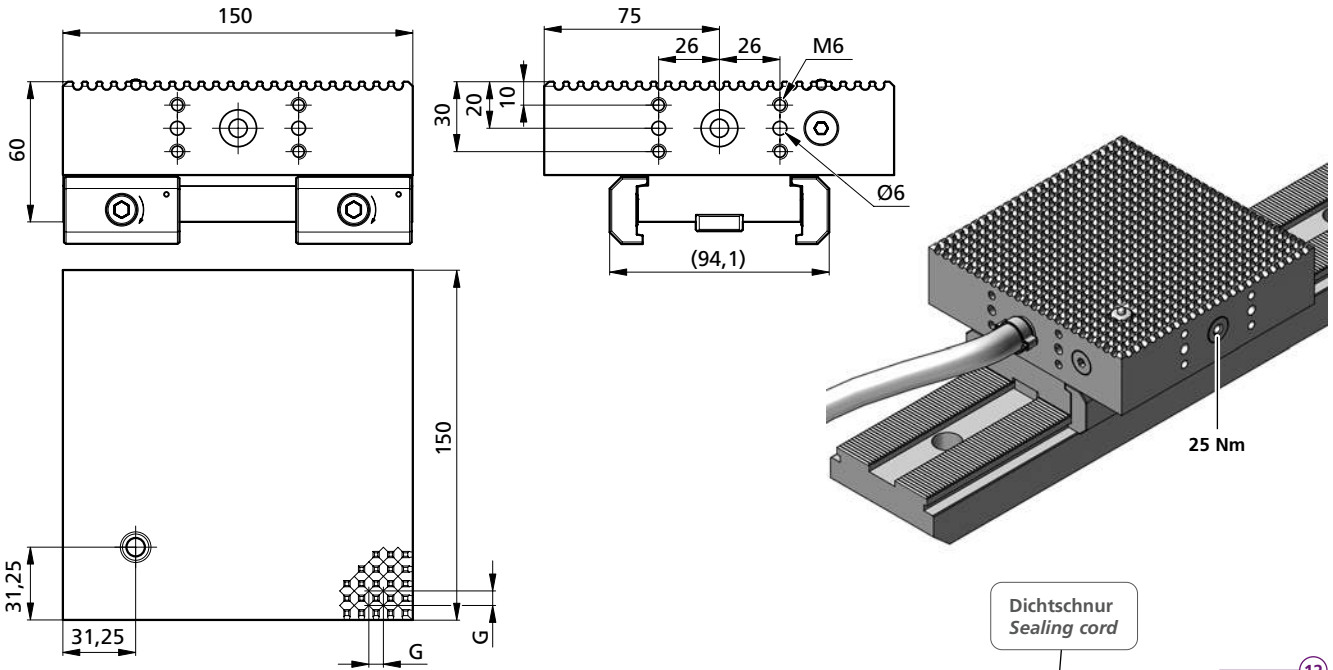

PS1X150L60-VAC

- ① 1x TW090017-01
- ② 1x 0700100
- ③ 3x 0920000
- ④ 4x M10X12ISO4027
- ⑤ 1x 0910001
- ⑥ 5x 1111003
- ⑦ 2x PCSP50R
- ⑧ 2x PCSP50L
- ⑨ 2x PCS14
- ⑩ 2x PCGU2049
- ⑪ 2x M6X8ISO7380
- ⑫ 1x 1120100 p. 324
- ⑬ 1x UA182540 p. 322
- ⑭ 1x UT1003040

G = 6,5 mm
kg ~3,6

Bestellbeispiel / Ordering example:

PS1X150L60-VAC & 1x 1120100 & 1x UA182540 & 1x UT1003040

Separat bestellen / Order separately

Vakuum-Modul für powerCLAMP

Vacuum module for powerCLAMP

PS1X80L31-VAC

trivaCLAMP

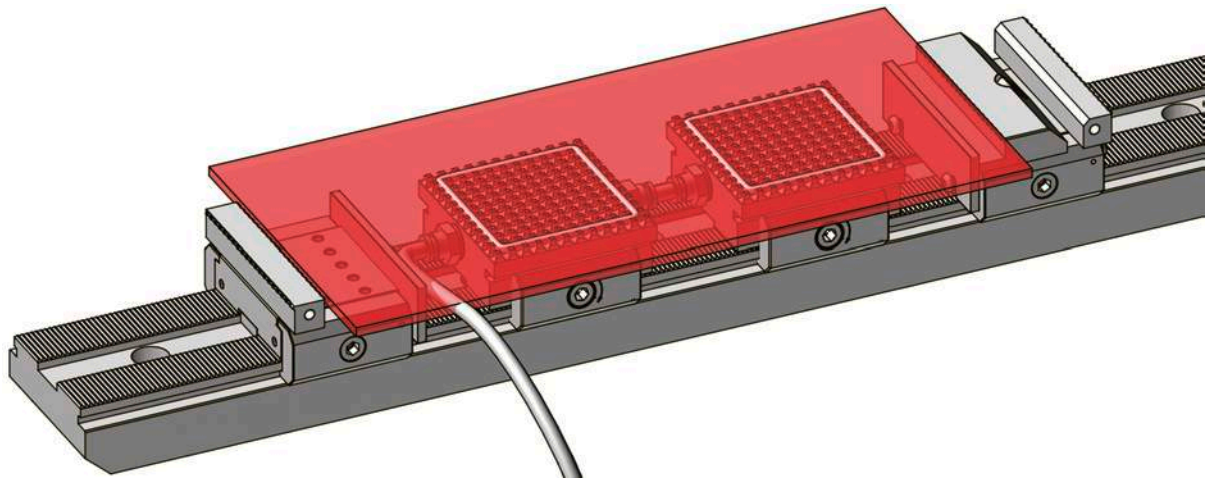
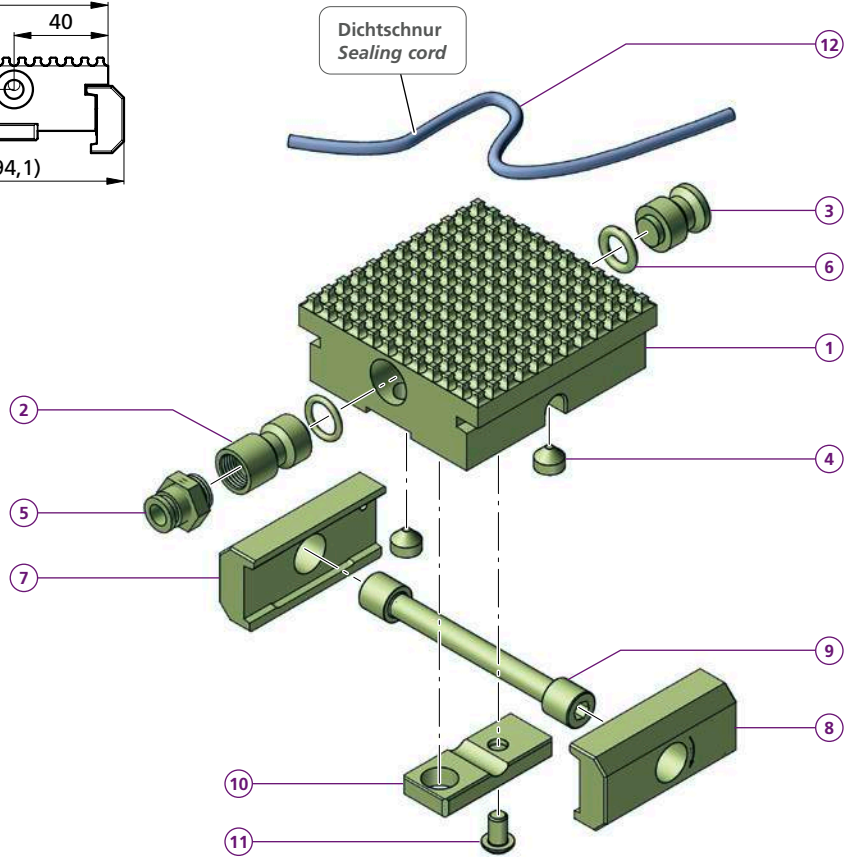
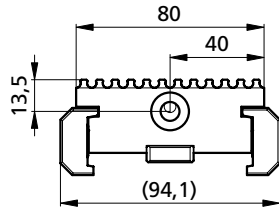
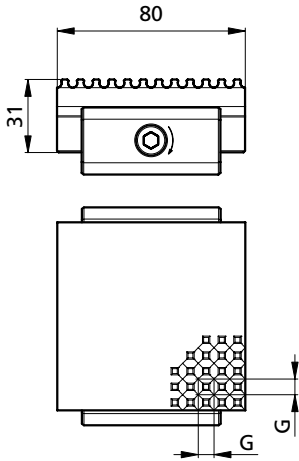

PS1X80L31-VAC

- ① 1x TH140263
- ② 1x UZV16301/4
- ③ 1x 0920000
- ④ 2x M10X8DIN914
- ⑤ 1x QSG1/4-8
- ⑥ 2x 1111003
- ⑦ 1x PCSP60R
- ⑧ 1x PCSP60L
- ⑨ 1x PCS14
- ⑩ 1x PCGU2049
- ⑪ 1x M6X8ISO7380
- ⑫ 1x 1120100

G = 6,5 mm
kg ~0,62

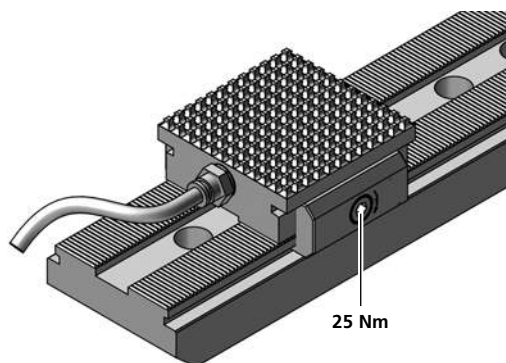

Bestellbeispiel / Ordering example: PS1X80L31-VAC & 1x 1120100

Separat bestellen / Order separately

Kombinationsvarianten (Vakuumpplatten)

Possible combination of vacuum plates

trivaCLAMP

UP15030040R50 G06 / G13

- Platte / Plate
- 1 x = 150 x 300
 - 2 x = 150 x 600
 - 2 x = 300 x 300
 - 4 x = 300 x 600

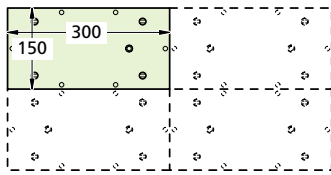

- 3 x = 300 x 450

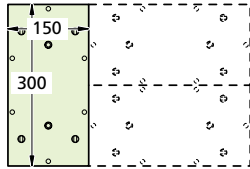

UP20030040R50 G06 / G13

- Platte / Plate
- 1 x = 200 x 300
 - 2 x = 200 x 600
 - 4 x = 400 x 600

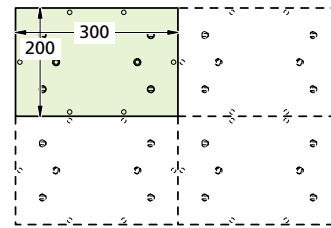

- 3 x = 300 x 600
- 4 x = 300 x 800

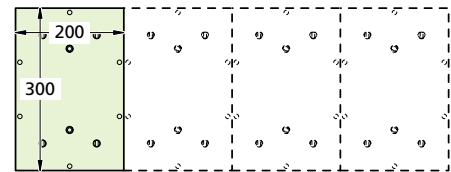

UP30060040R50 G06 / G13

- Platte / Plate
- 1 x = 300 x 600
 - 2 x = 600 x 600
 - 3 x = 600 x 900
 - 4 x = 600 x 1200

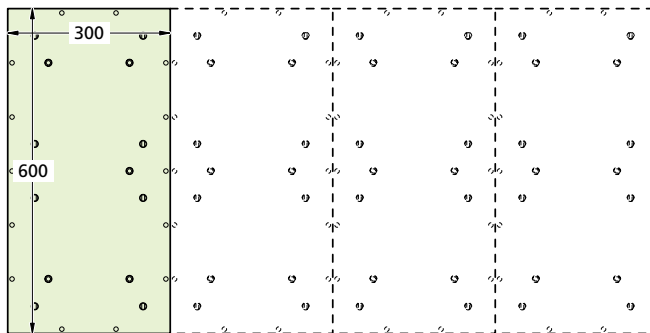

UP30060040R50 G06 / G13

- Platte / Plate
- 1 x = 300 x 600

UP20030040R50 G06 / G13

- Platte / Plate
- 2 x = 200 x 300

- = 500 x 600

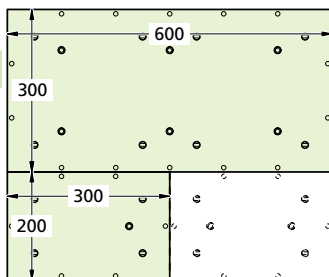

UP30060040R50 G06 / G13

- Platte / Plate
- 2 x = 300 x 600

UP20030040R50 G06 / G13

- Platte / Plate
- 2 x = 200 x 300

- = 600 x 800

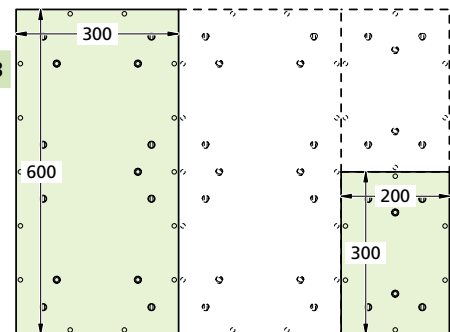

UP50050040R50 G06 / G13

- Platte / Plate
- 2 x = 500 x 1000

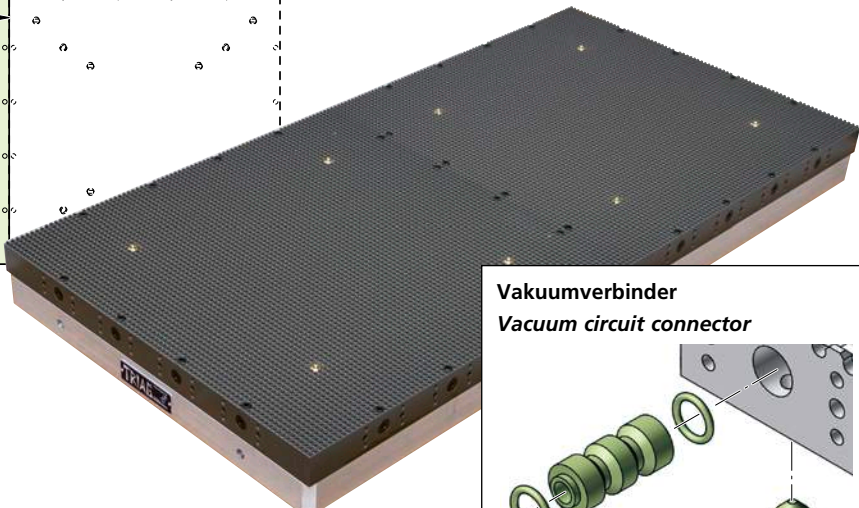
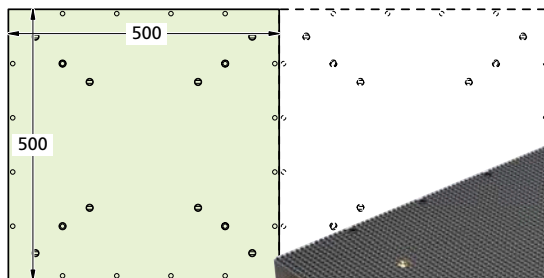

Vakuumverbinder
Vacuum circuit connector

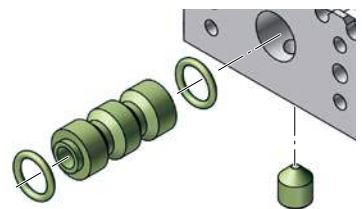

UPSET	D	1	V	G...	
<p>A UP50050040R50G13 500 500 UF50050050R50 G</p> <p>B UP30060040R50G13 300 600 UF30060050R50 H</p> <p>C UP20030040R50G13 200 300 UF20030050R50 I</p> <p>D UP15030040R50G13 150 300 UF15030050R50 J</p> <p>E PS1X150L60-VAC G06</p> <p>F PS1X80L31-VAC G06</p>	<p>1 UPB1JN 1</p> <p>2 UPB2JN 2</p> <p>3-5 UBA ...</p>	<p>UA3-660</p> <p>UT1003040 V</p> <p>UA0770</p> <p>UZA5015G13</p> <p>UZA4012G06</p> <p>UA182540</p>	<p>G13 G06</p> <p>Vakuumpalte Vacuum plate</p> <p>A 500 x 500 (UP50050040R50 G06 / G13) B 300 x 600 (UP30060040R50 G06 / G13) C 200 x 300 (UP20030040R50 G06 / G13) D 150 x 300 (UP15030040R50 G06 / G13) E 150 x 60 (PS1X150L60-VAC) F 80 x 31 (PS1X80L31-VAC) G 500 X 500 (UF50050050R50) H 300 X 600 (UF30060050R50) I 200 X 300 (UF20030050R50) J 150 X 300 (UF15030050R50)</p>	<p>Vakuum erzeugen Generate vacuum</p> <p>1 UPB1JN 2 UPB2JN 3 UBA106230300 4 UBA106110250 5 UBA318400550</p>	<p>Zubehör Accessories</p> <p>Z 2x UT1003040 1x UA182540 1x UA3-660 Y 2x UT1003040 1x UA182540 1x UA3-560 X 2x UT1003040 1x UA182540 1x UA3-360 W 2x UT1003040 1x UA182540 1x UA2-260 V 2x UT1003040 1x UA182540 2x UA0770 U 4x UZA4012G06 T 4x UZA5015G13</p>
<p>Zu jedem SET werden zusätzlich 3 m Vakuumschlauch (0941000) und 25 m Dichtschnur mitgeliefert (1120100) Ø 4 oder (1110100) 6 mm inkl. (2 x 10100024). Each SET is supplied with an additional 3 m vacuum hose (0941000) and 25 m sealing cord (1120100) Ø 4 or (1110100) 6 mm incl. (2 x 10100024).</p> <p>Vakuumschlauch Vacuum hose 3 m: 0941000</p> <p>Dichtschnur Sealing cord 25 m: 1120100</p> <p>Bestellbeispiel / Ordering example: UPSETD1VG13</p>					

Anschlagleisten
Stop rails

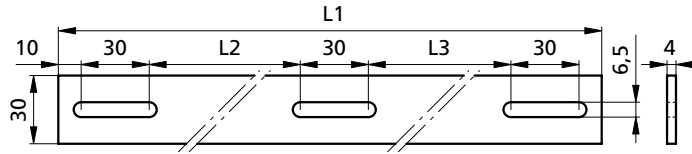

UA3-660	
1	1x TH160274
2	3x M6X12ISO4762
3	3x 6,4 DIN9021
4	3x SM1135M6X8
L1	= 660 mm
L2	= 270 mm
L3	= 280 mm
kg	~0,6

UA3-560	
1	1x TH160275
2	3x M6X12ISO4762
3	3x 6,4 DIN9021
4	3x SM1135M6X8
L1	= 560 mm
L2	= 225 mm
L3	= 225 mm
kg	~0,5

UA3-360	
1	1x TH160277
2	3x M6X12ISO4762
3	3x 6,4 DIN9021
4	3x SM1135M6X8
L1	= 360 mm
L2	= 120 mm
L3	= 130 mm
kg	~0,32

UA2-260	
1	1x TH160278
2	2x M6X12ISO4762
3	2x 6,4 DIN9021
4	2x SM1135M6X8
L1	= 260 mm
L2	= 180 mm
L3	= 180 mm
kg	~0,2

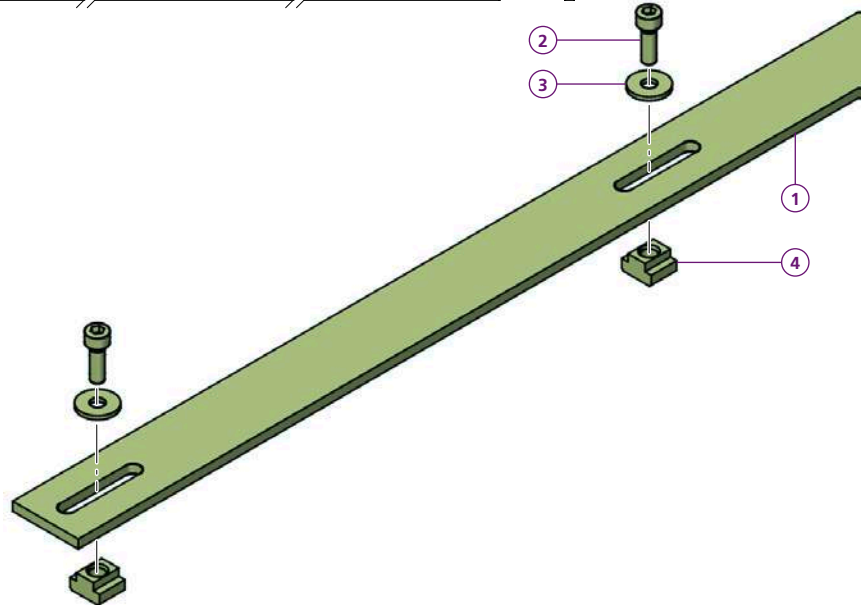

Anschlag
Stop rail

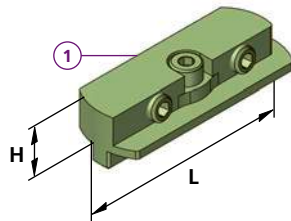

UZA5015G13	
1	1x TB170561
L	= 50 mm
H	= 9 mm
kg	~0,04



Bedienungsanleitung zu diesen zwei Anschlägen
Operating instructions for these two stops

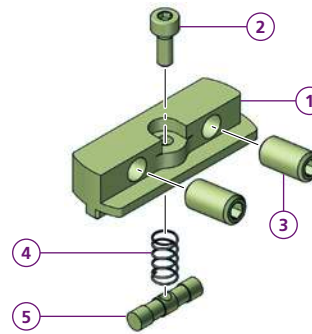

UZA4012G06	
1	1x TB170558
2	1x M4X10ISO4762
3	2x M6X16 DIN913
4	1x TN100535
5	1x TB170562
L	= 40 mm
H	= 8,5 mm
kg	~0,03

T-Nuten Stein
T-nuts

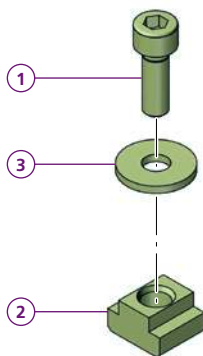

0802000-SET	
1	1x M6X12ISO4762
2	1x SM1135M6X8
3	1x 6,4 DIN9021
kg	~0,03

Ansetzbare T-Nuten
Attachable T-slots

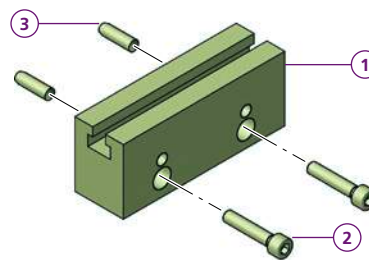

UT1003040	
1	1x TH160227
2	2x M6X25ISO4762
3	2x 6X20-B ISO8734
kg	~0,4

Seiten-/Wendeanschlag
Reversible stop gage

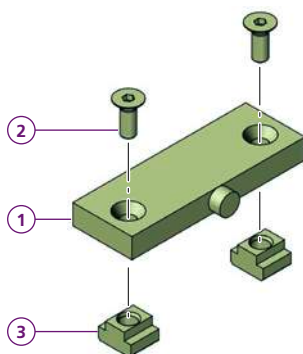

UA0770	
1	1x TH160259
2	2x TN100899
3	2x SM1135M6X8
kg	~0,14

Seitenanschlag
Side lay

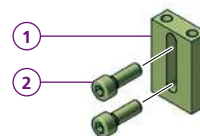

UA182540	
1	1x TH160098
2	2x M6X18ISO4762
kg	~0,1

Vakuumverbinder Vacuum circuit connector

Koppelemente Link-up plug

trivaCLAMP

Vakuumverbinder
Vacuum circuit connector

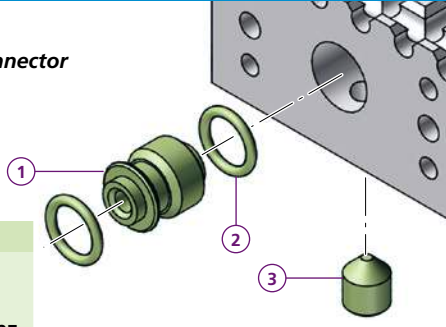

- 0930000**
- ① 1x TK110401
 - ② 2x 1111003
 - ③ 1x M10X12ISO4027
- kg ~0,02

Blindstopfen
Blind plug

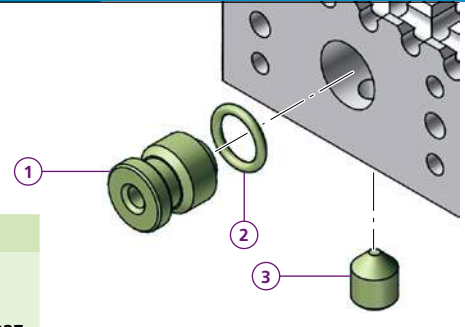

- 0920000**
- ① 1x TK110402
 - ② 1x 1111003
 - ③ 1x M10X12ISO4027
- kg ~0,03

Koppelement
Link-up plug

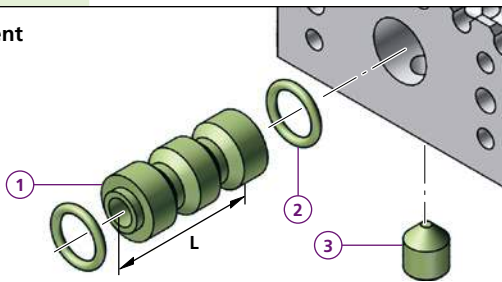

- 0910000**
- ① 1x TK110403
 - ② 2x 1111003
 - ③ 1x M10X12ISO4027
- L = 40 mm
- kg ~0,03

- 0910080**
- ① 1x TK140763
 - ② 2x 1111003
 - ③ 1x M10X12ISO4027
- L = 80 mm
- kg ~0,04

Vakuumverbinder
Vacuum circuit connector

- TS150487**
- ① 1x TS150487
 - ② 2x TN100682
- d = 5,8 mm
- D = 15 mm

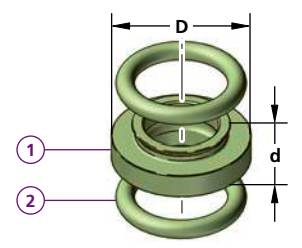

Anschlüsselement
Adapter element

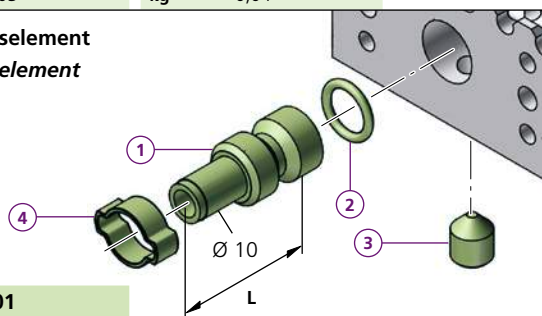

- 0910001**
- ① 1x TK110404
 - ② 1x 1111003
 - ③ 1x M10X12ISO4027
 - ④ 1x 10100024
- L = 40 mm
- kg ~0,04

Vakuumschlauch (per Laufmeter)
Vacuum hose (per running meter)

- D = 8 mm für Vakuumanbindung von Platte zu Platte
for vacuum supply from plates to accessories
- D = 16 mm für Vakuumverbindung von Pumpe zu Platten
for vacuum supply from pump to plate



- | | |
|----------------|----------------|
| 0940800 | 0941000 |
| D = 8 mm | D = 16 mm |
| d = 5,5 mm | d = 10 mm |

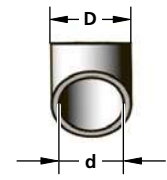

Vakuumverbinder
Vacuum circuit connector

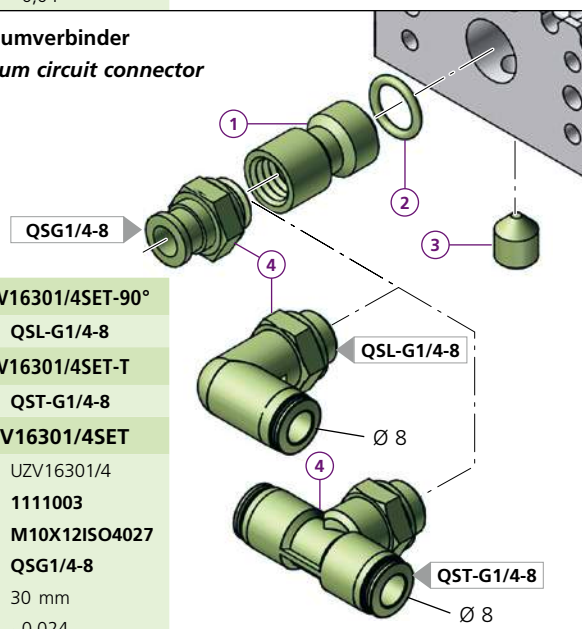

- UZV16301/4SET-90°**
- ④ 1x QSL-G1/4-8
- UZV16301/4SET-T**
- ④ 1x QST-G1/4-8
- UZV16301/4SET**
- ① 1x UZV16301/4
 - ② 1x 1111003
 - ③ 1x M10X12ISO4027
 - ④ 1x QSG1/4-8
- L = 30 mm
- kg ~0,024

Verbindungsschlauch mit Koppelementen
Connector-tube with link-ups

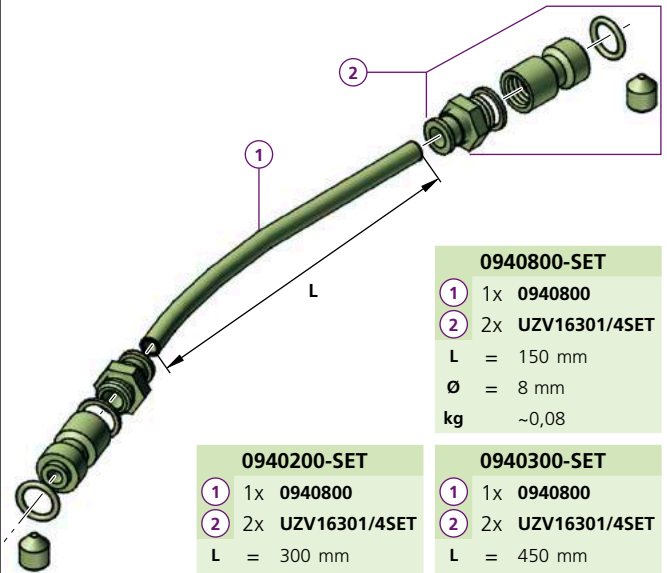

- 0940800-SET**
- ① 1x 0940800
 - ② 2x UZV16301/4SET
- L = 150 mm
- Ø = 8 mm
- kg ~0,08

- 0940200-SET**
- ① 1x 0940800
 - ② 2x UZV16301/4SET
- L = 300 mm
- Ø = 8 mm
- kg ~0,08

- 0940300-SET**
- ① 1x 0940800
 - ② 2x UZV16301/4SET
- L = 450 mm
- Ø = 8 mm
- kg ~0,09

Dichtschnüre aus Silikon-Gummi

Beständig gegen Öle, Säuren, Emulsionen, Dielektrika, ionisiertes Wasser und Wärme bis 200°C

Silicone-rubber sealing cord

Resistant to oils, acids, coolants, dielectrics, activated water (EDM) and heat up to 200°C

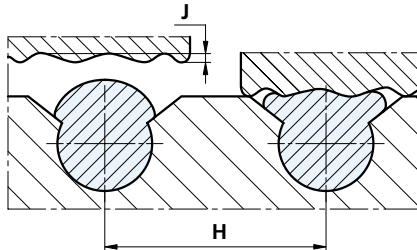

Dichtschnüre aus Gummi

- ölbeständig
- für spezielle Vorrichtungen

Rubber sealing cord

- oil resistance
- to fit special devices

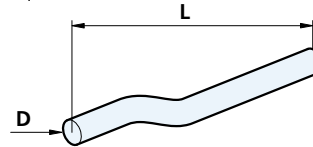

G13



G06

weiss / white

1110100	1120100	1120100M	1130000
L = 25 m	L = 25 m	L = 25 m	L = 5 m
D = 6,5 mm ±0,5	D = 4 mm (4,3-4,6 mm)	D = 4 mm (4,0-4,3 mm)	D = 3 mm
J = max. 0,6 mm	J = max. 0,4 mm	J = max. 0,3 mm	
H = 12-13 mm	H = 6-7 mm	H = 6-7 mm	



G13

schwarz / black

weiss / white

1110100S	1110100SP	0130001	0130002
L = 25 m	L = 25 m	L = 1 m	L = 1 m
D = 6,0-6,5 mm	D = 6,6-7,0 mm	D = 2,15 mm	D = 1,65 mm
J = max. 0,6 mm	J = max. 0,6 mm		
H = 12-13 mm	H = 12-13 mm		

Triva Clamp Ventil / Triva Clamp valve

Montage von oben
Mounting from above

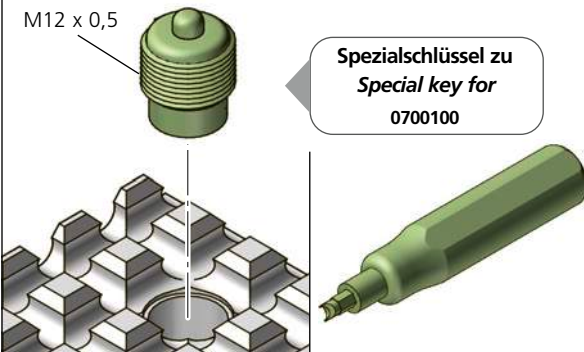

0700100 kg ~0,01

Triva Bit kg ~0,14

Ventil-Blindstopfen
Valve blind plug

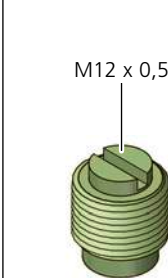

0700102 kg ~0,01

Montage von unten, für Spezialvorrichtungen
Mounting from bottom side, for special devices

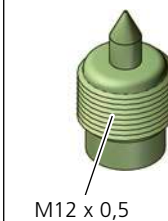

0700200 kg ~0,01

Reduktionstück für Rasterplatten M12/12^{f7} auf M6
Adapter piece for Gridplates from M12/12^{f7} to M6

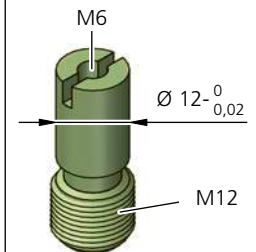

ADAPT6-12 kg ~0,02

Schnellkupplung mit Bride Quick hose coupling including clip

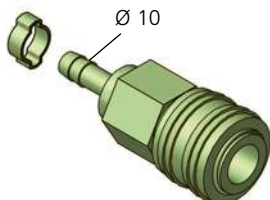

0520000 kg ~0,14

Schlauchnippel mit Bride Hose nozzle including clip

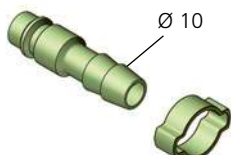

0941010 kg ~0,03

VHM Profilfräser für Vorrichtungplatten Carbide end mills for plate for dedicated fixtures

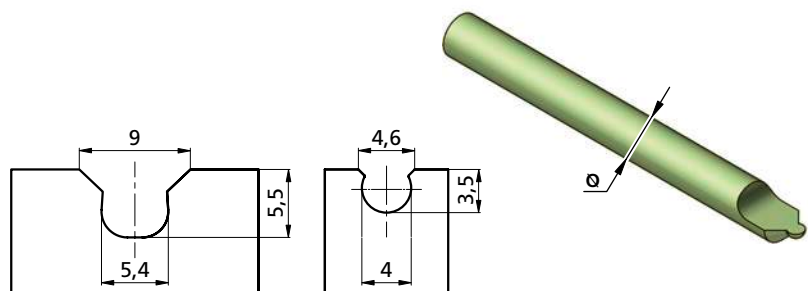

G13

VFP10065L100 (Ø 6,5 mm)

Ø = 10
L = 100



G06

VFP08040L90 (Ø 4 mm)

Ø = 8
L = 90

Rotationspumpe auf Speichertank für Arbeiten mit Kühlwasser

Aggregat ausgerüstet mit:

- Vakuumpumpe, Enddruck 20 mbar
- Wasserabscheider mit Sintermetallfilter
- Fahrbarem 50 Liter Behälter als Vakuumspeicher und Wasserreservoir
- 5 Meter Vakuumschlauch
- für 3-Phasenbetrieb wartungsfreie Drehstrommotoren
- für 1-Phasenbetrieb wartungsfreie Motoren mit Anlauf-Kondensatoren.

für Vakuumaufspannflächen:

- zusammenhängend, oder auf mehrere einzelne Platten verteilt

Rotary pumptank assembly Pump assembly for machining with flowing coolant

Assembly equipped with:

- Vacuum pump, pressure limit 20 mbar
- Liquid separator with sintered metall filter
- Pump mounted on a movable 50l (13gal) tank being both, vacuum reservoir and water collector
- 5 m (6.5ft) Vacuum hose
- maintenance-free motors for 3 phase operating
- single phase motors with capacitor starter.

To cover maximum holding surface:

- built by plate or plate-assembly, or display over several single plates mounted to various machine-tools

Technische Daten
Technical data

Saugkraft
Suction capacity

Spannfläche bis / Surface up to 1,8 m²

3-Phasen / Triple phase 400 V ± 10%, 50 / 60 Hz, 250 / 300 W	6 / 7,2 m ³ /h	UBA306400250
1-Phasen / Single phase 230 V ± 10%, 50 / 60 Hz, 300 / 360 W	6 / 7,2 m ³ /h	UBA106230300
1-Phasen / Single phase 110 V ± 10%, 60 Hz, 250 / 300 W	6 / 7,2 m ³ /h	UBA106110250

Spannfläche bis / Surface up to 5,0 m²

3-Phasen / Triple phase 400 V ± 10%, 50 / 60 Hz, 550 / 660 W	18 / 21 m ³ /h	UBA318400550
1-Phasen / Single phase 230 V ± 10%, 50 / 60 Hz, 600 / 720 W	18 / 21 m ³ /h	UBA118230600

Separater Tank / Separate tank

UBT40
Vol. 40l

Öl für Vakuumpumpe / Oil for vacuum pump

UB1-OIL
Vol. 1l



Bedienungsanleitung zu diesem Vakuumpumpen
Operating instructions for this vacuum pump

➔ Grössere Pumpen auf Anfrage
➔ Larger pumps on demand

Schaltventil und Druckwächter

Control unit with pressure sensor switch

trivaCLAMP

Schaltventil
Control unit

TN100668 kg ~0,096

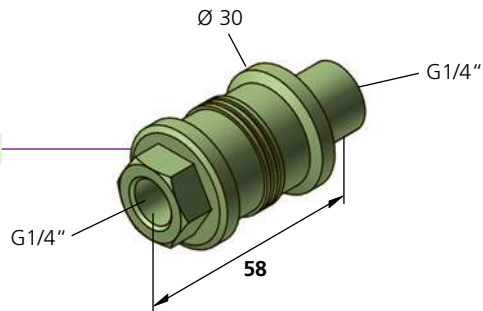

Schaltventil mit Unterdruckanzeige
Control unit valve with vacuum indicator

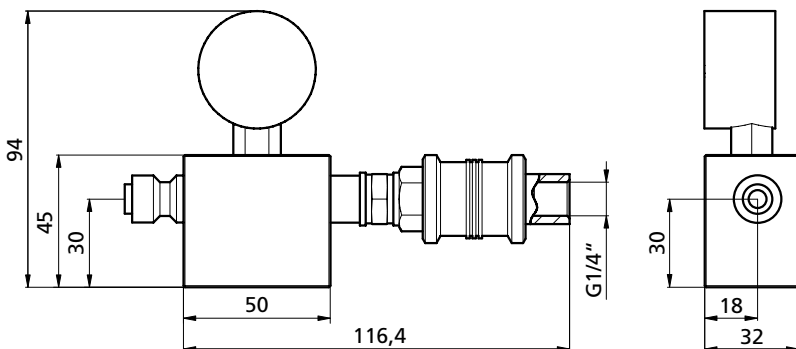

UBS5045

- 1 1x UBS5045-1
- 2 1x 0910000
- 3 3x TN100822
- 4 1x 0920000
- 5 3x TN100086
- 6 1x TN100671
- 7 2x TN100642
- 8 1x TN100925
- 9 1x TN100668
- 10 1x TH120180

kg ~0,74

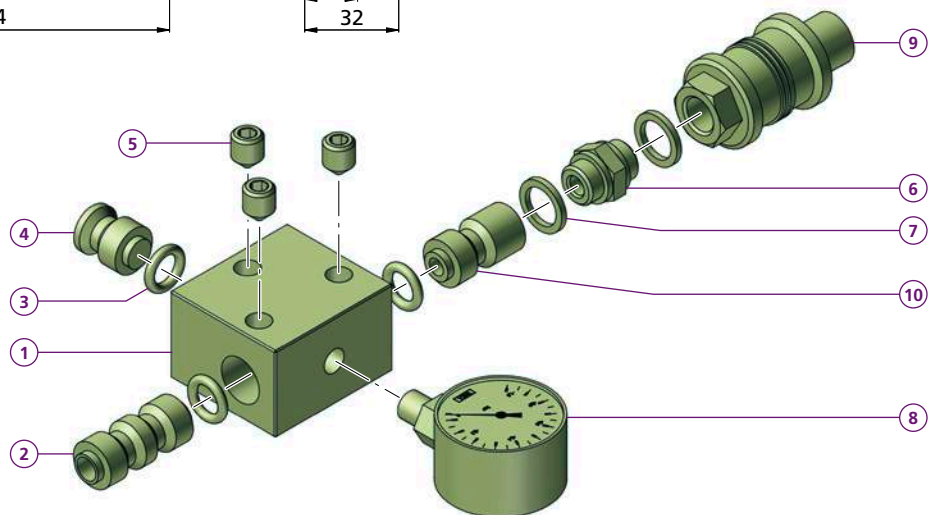

Druckwächter / Pressure sensor switch

Druck einstellbar; je nach Aufspannung einzustellen.

With adjustable threshold value; to be adjusted according to clamping task.

Anschluss 24-250 V, 50-60 Hz am Ausgang (R) für Elektrokabel zu optischem oder akustischem Warnsignal, oder zum Stillsetzen der Werkzeugmaschine über deren Steuerung, normalerweise mit Funktion M 00 (Programm Stop).

Power supply (24-250 V, 50-60 Hz). Connecting point (R) for wiring to trigger a signal (light or whistle) or to switch the machine tool off via its control system, normally using function M 00 (machine stop), in the event of a drop of vacuum.

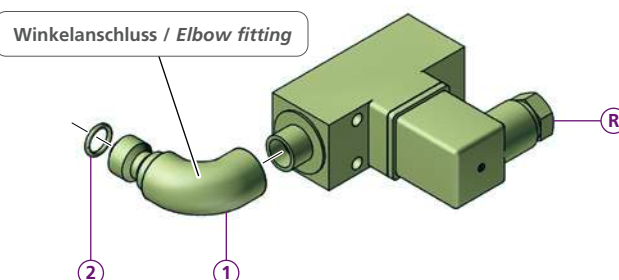

0500205

- 1 1x 0940000
- 2 1x 1111003

➔ Weiteres Zubehör auf Anfrage
➔ Further accessories on demand

Vakuumschleuse auf Power-Clamp mit Injektorpumpe für Trocken- und Nasseinsatz

Das modulare Triag Power Clamp Spannsystem kann nun mit Vakuumschleusen bestückt werden. Die Vakuumschleusen können mit oder ohne Zwischenräume gekoppelt werden. Die handliche Injektorpumpe wird mit Pressluft betrieben und kann im Trocken- oder Nasseinsatz verwendet werden.

Vacuum clamping plates on Power - Clamp with injector pump for dry and wet use

The modular Triag Power Clamp workholding system can now be equipped with vacuum plates. The vacuum plates can be coupled with or without gaps. The handy injector pump is operated with compressed air and can be used in dry and wet applications.

Maximaler zulässiger Speisedruck: 7 bar
Maximal erreichbares Vakuum: 0,92 bar

Maximum allowable supply pressure: 7 bar
Maximum attainable vacuum: 0,92 bar

Der Normalliter (NI) entspricht dem Volumen, das eine bestimmte Menge (Masse) Gas bei atmosphärischem Druck einnehmen würde. Die Durchflussmenge wird berechnet aus Volumen pro Zeit (NI/s) unter Normalbedingungen (atmosphärischer Druck, 20°C).

The normal litres (NI) is the volume that would take a certain amount (mass) of gas at atmospheric pressure. The flow rate is calculated as volume per time (NI/s) under normal conditions (atmospheric pressure, 20°C).

Typ	Speisedruck	Luftverbrauch	Saugleistung bei 50% Vakuum	Saugleistung bei 90% Vakuum
Type	Feed pressure	Air consumption	Vacuum suction power at 50%	Vacuum suction power at 90%
	bar	NI/s	NI/s	NI/s
UPB1JN	5	2,0	0,6	0,02
	6	2,3	0,5	0,03
UPB2JN	5	4,0	1,2	0,04
	6	4,6	1,0	0,06

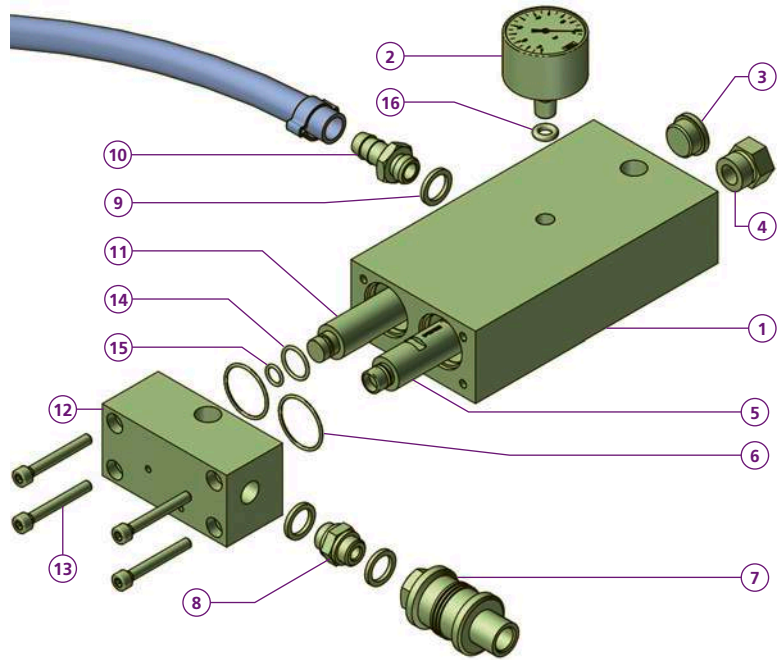
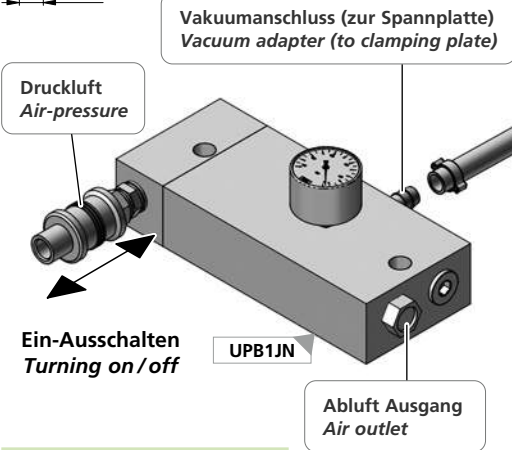
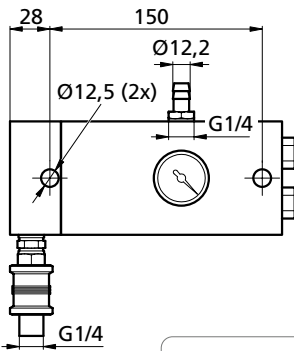
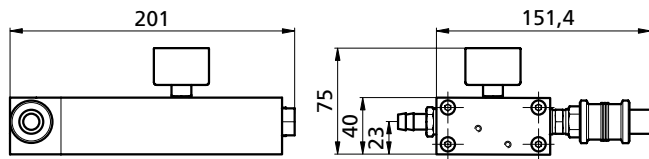

- UPB1JN**
- 1 1x TW090057
 - 2 1x TN100667
 - 3 1x TN100660
 - 4 1x TW100199
 - 5 1x TN100665
 - 6 2x TN100057
 - 7 1x **TN100668**
 - 8 1x TN100671
 - 9 3x TN100642
 - 10 1x TN100664
 - 11 1x TW090057
 - 12 1x TW90057-02
 - 13 4x TN100666
 - 14 1x TN100691
 - 15 1x TN100163
 - 16 1x TN100654
- kg ~1,61

- UPB2JN**
- 1 1x TW090057
 - 2 1x TN100667
 - 4 2x TW100199
 - 5 2x TN100665
 - 6 2x TN100057
 - 7 1x **TN100668**
 - 8 1x TN100671
 - 9 3x TN100642
 - 10 1x TN100664
 - 12 1x TW90057-02
 - 13 4x TN100666
 - 14 1x TN100691
 - 15 1x TN100163
 - 16 1x TN100654
- kg ~1,67

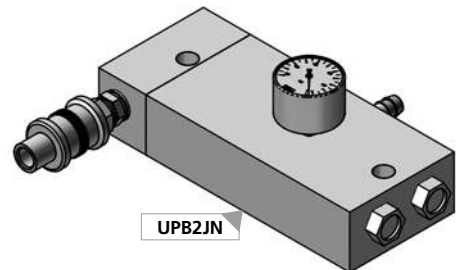

Bestellbeispiel / Ordering example: **UPB1JN**

Separat bestellen / Order separately

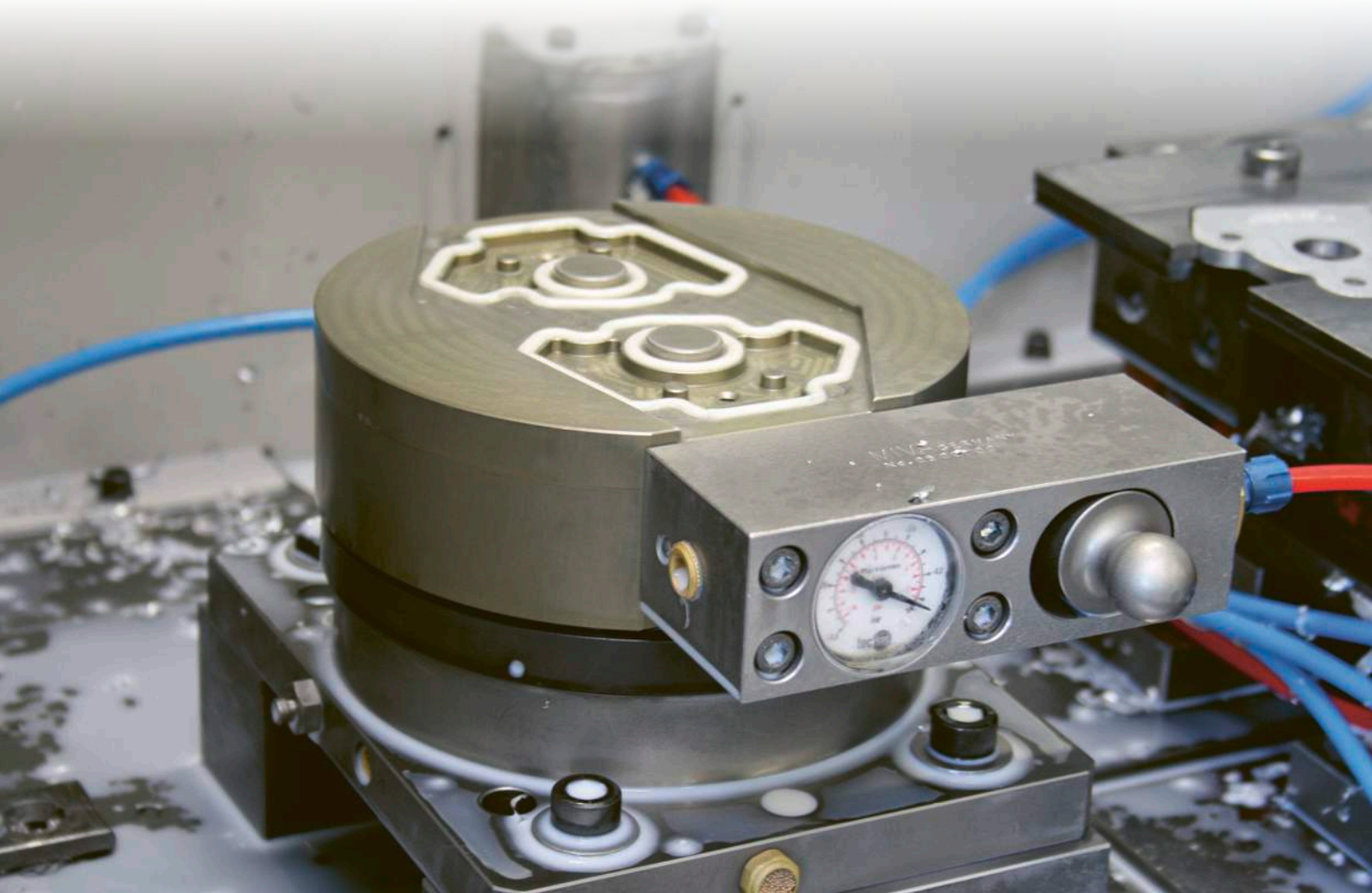



SPECIALS

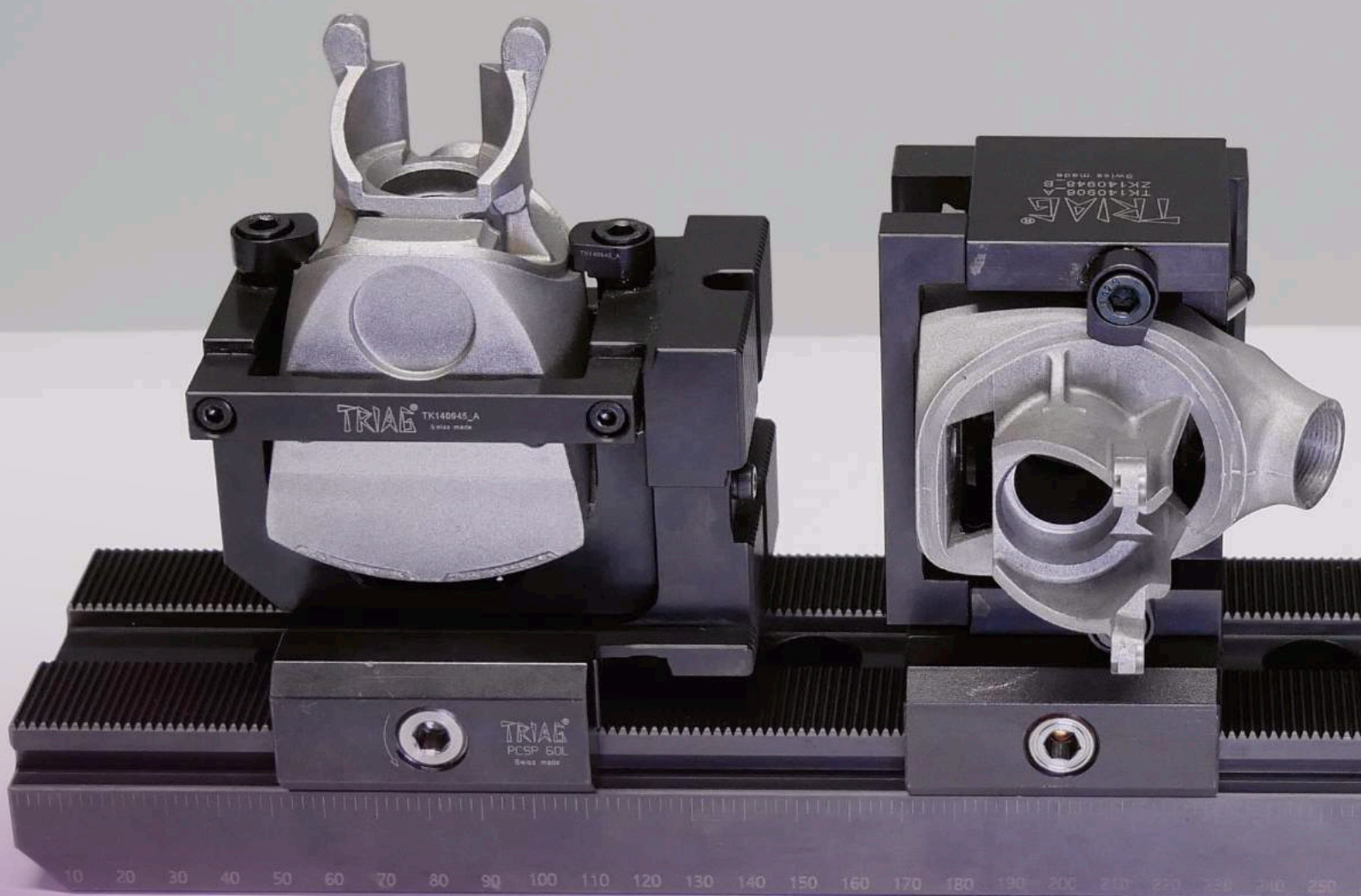

Fordern Sie uns heraus! *Challenge us!*



Wir sind Ihr Spezialist für Sondervorrichtungen.
Nehmen Sie mit uns Kontakt auf.

*We are your specialist for custom made fixtures.
Feel free to contact us.*



Komplexe Teile einfach gespannt *Complex parts simply clamped*



Drei Sonderspannmodule mit powerCLAMP Schnittstelle für komplex geformte Aluminium Druckguss Teile.

Three customized clamping modules with powerCLAMP interface for complex shaped die cast aluminium pieces.

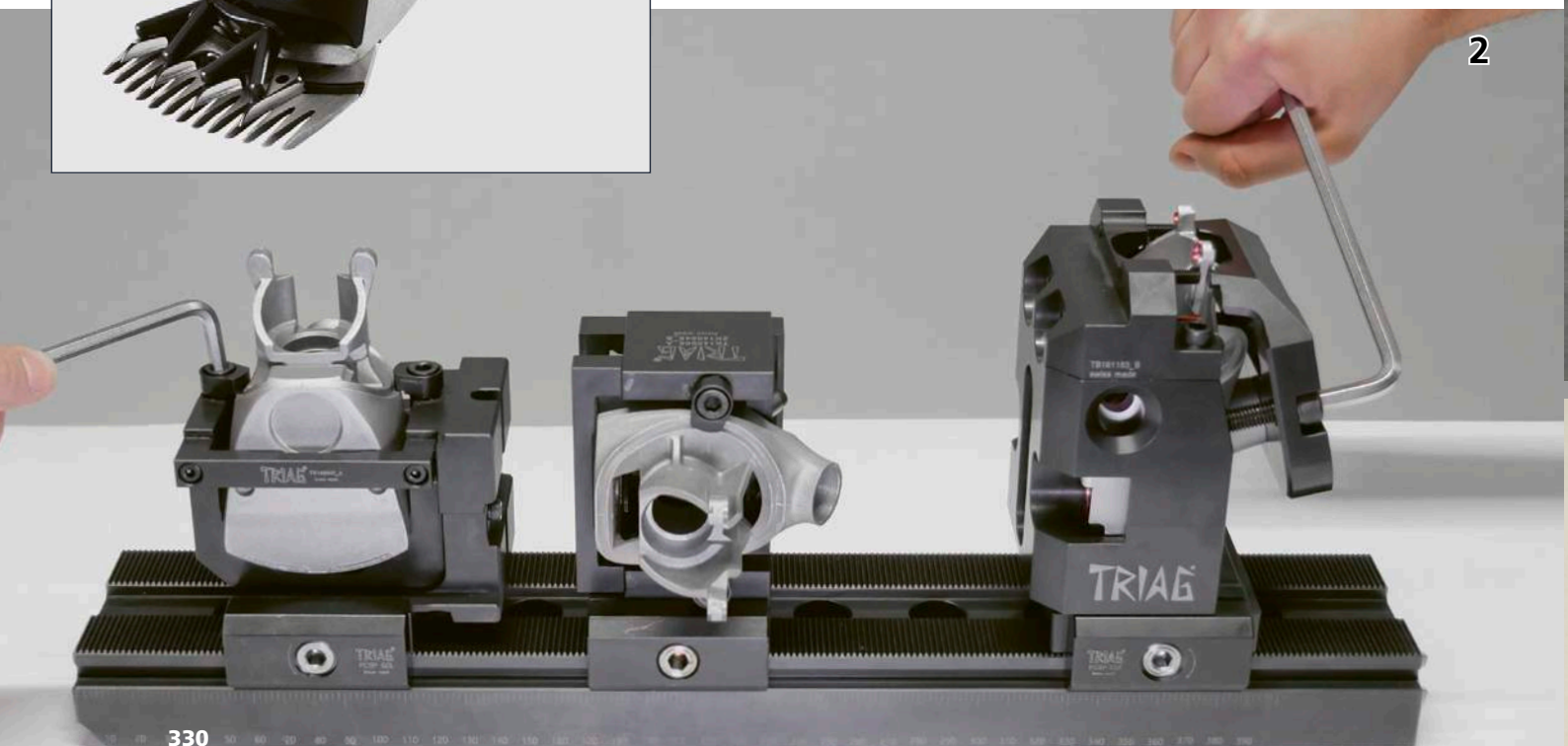



3

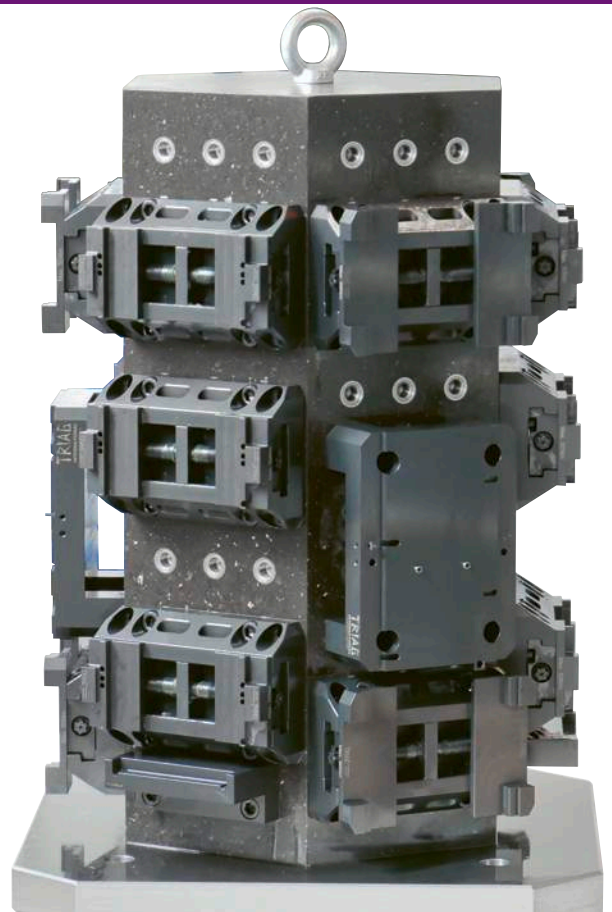

4

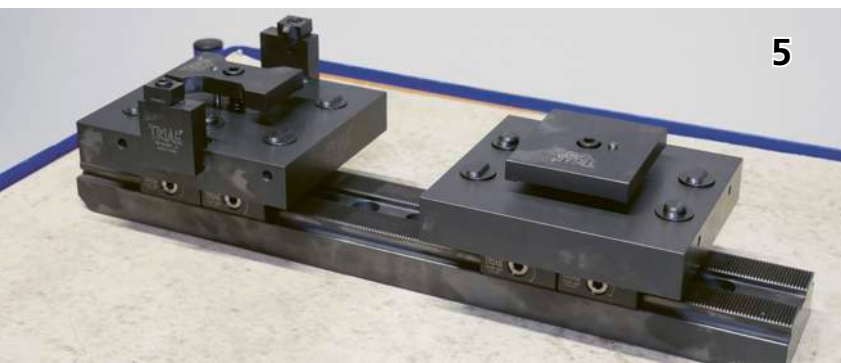

5

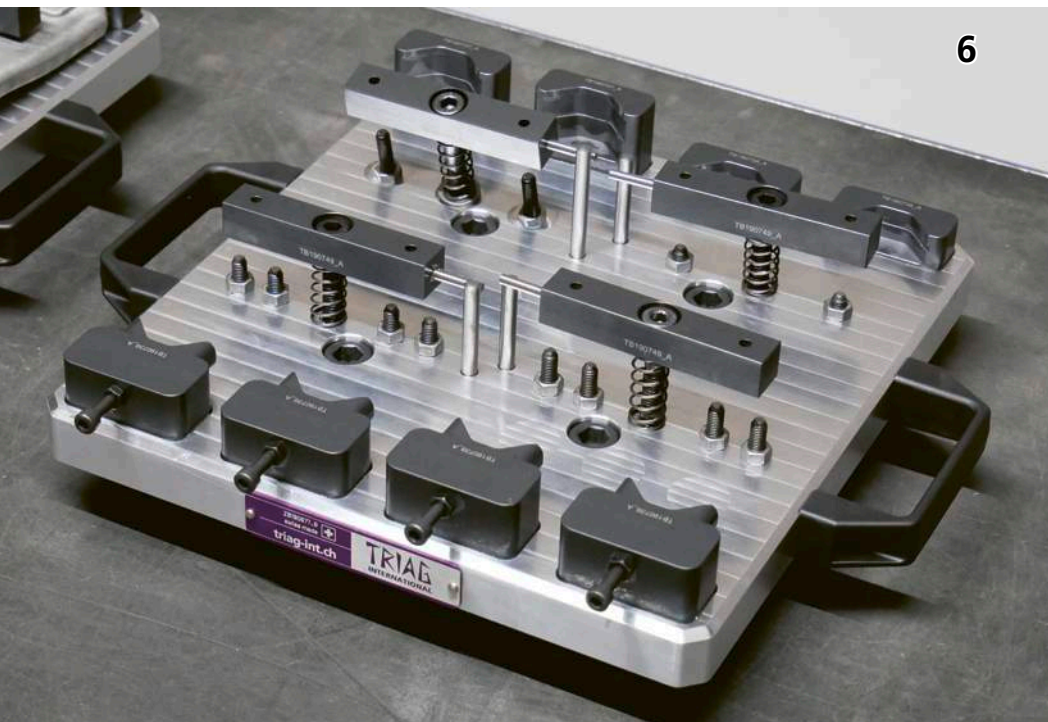

6

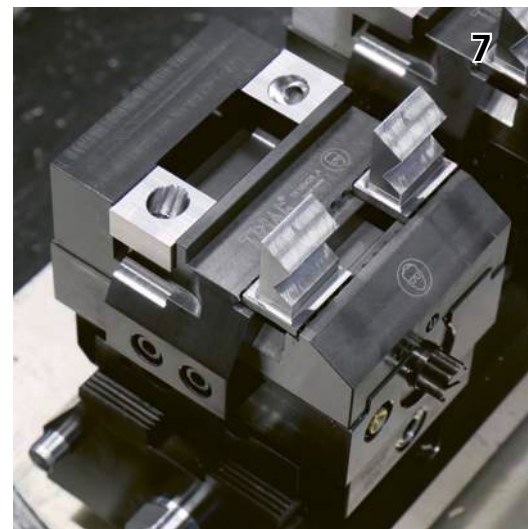

7



8



9





Zubehör Accessories

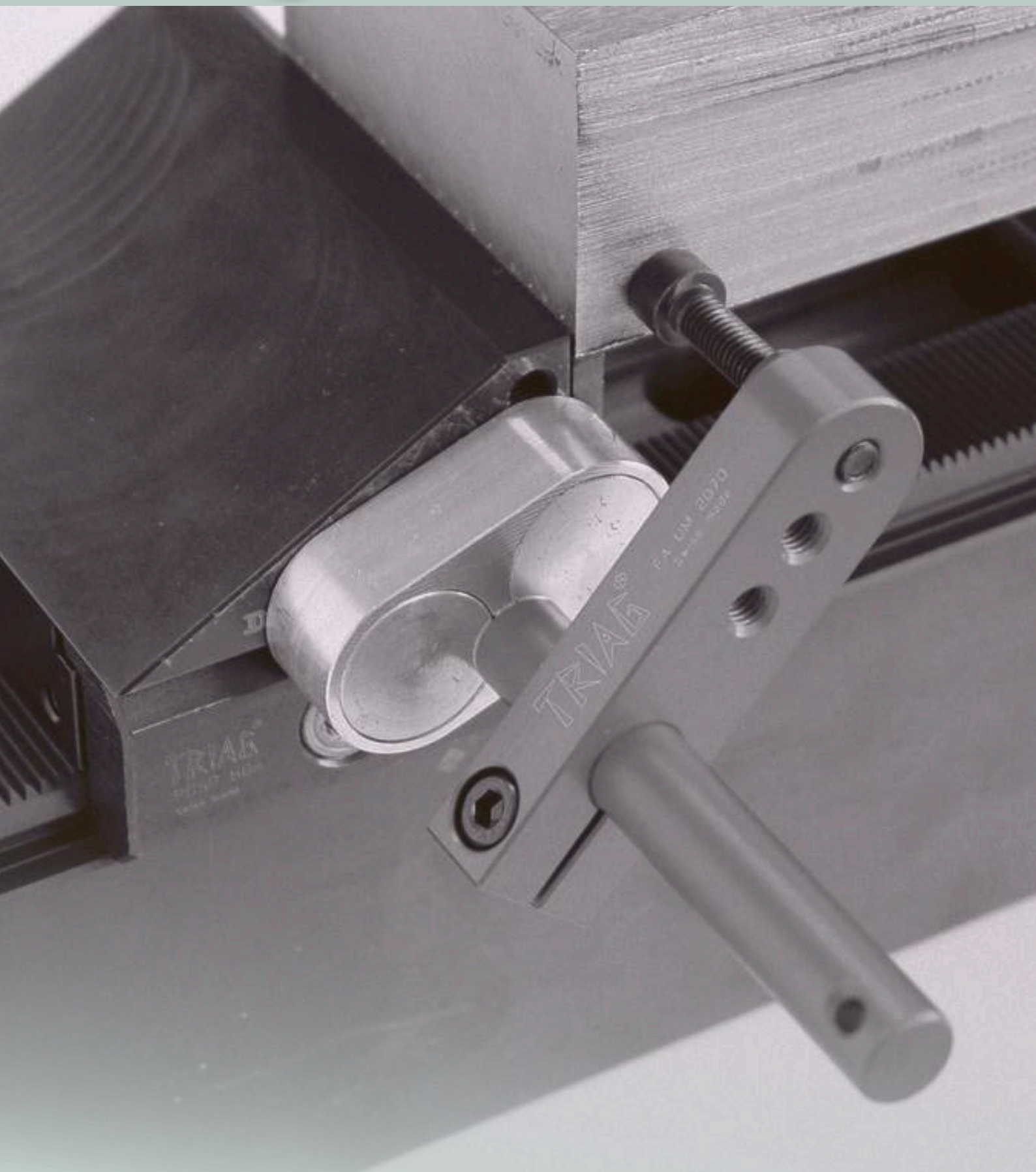

Einstellmasstab | *Measuring device* 335



Magnetanschlag | *Magnetic milling buffer* 336

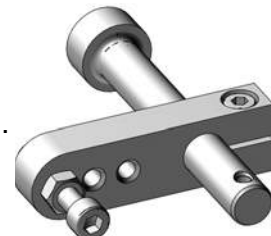

Fräsanschlag / Hartmetalldruckstück | *Milling buffer / Carbide gripper* 337

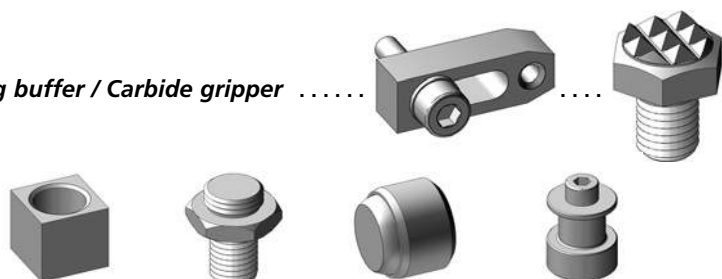

Stopfen / Spanschrauben / Passschrauben / T-Nuten Steine
Plug / Clamping screw / Fitting screw / T-slot nuts 338

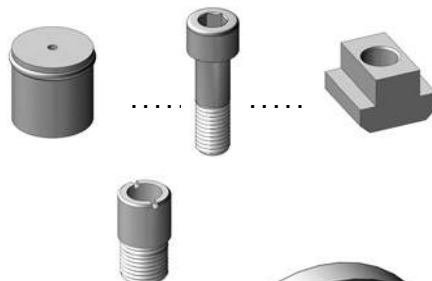

Triag Bitburr / Magnethalter / Pneumatikschrauber Set
Magnetic holder / Pneumatic screwdrivers set 339

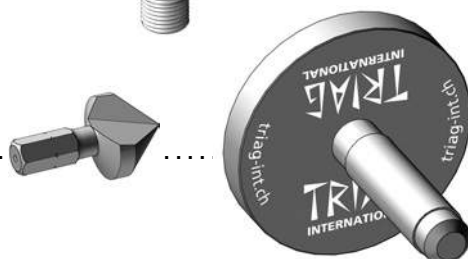

Drehmomentschlüssel / Spanschlüssel / Messingdrahtbürste
Torque wrenches / Clamping wrench / Brass wire brush 340

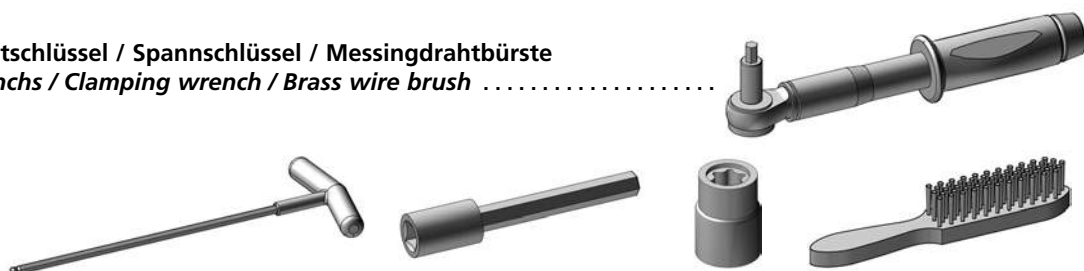

Masstab mit Magnetleiste

Scale with magnet profile

PCMAS800ML

- ① 1x PCMAS800ML
 - ② 2x MG1645
 - ③ 2x M3X10ISO4762
 - ④ 1x M6X12BN5128
- kg ~1,0

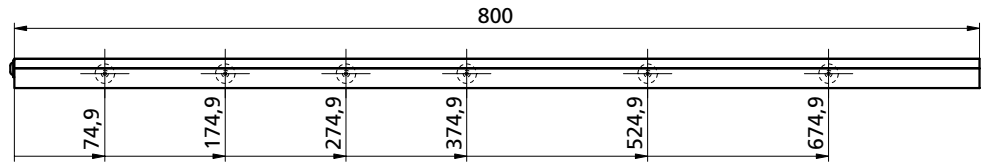

PCMAS700ML

- ① 1x PCMAS800ML
 - ② 2x MG1645
 - ③ 2x M3X10ISO4762
 - ④ 1x M6X12BN5128
- kg ~0,88

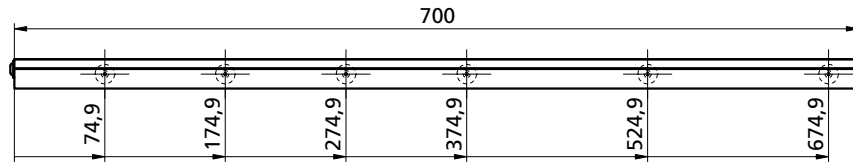

PCMAS600ML

- ① 1x PCMAS800ML
 - ② 2x MG1645
 - ③ 2x M3X10ISO4762
 - ④ 1x M6X12BN5128
- kg ~0,75

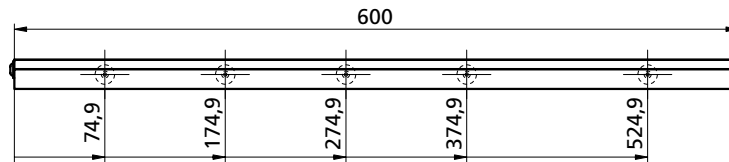

PCMAS500ML

- ① 1x PCMAS800ML
 - ② 2x MG1645
 - ③ 2x M3X10ISO4762
 - ④ 1x M6X12BN5128
- kg ~0,63

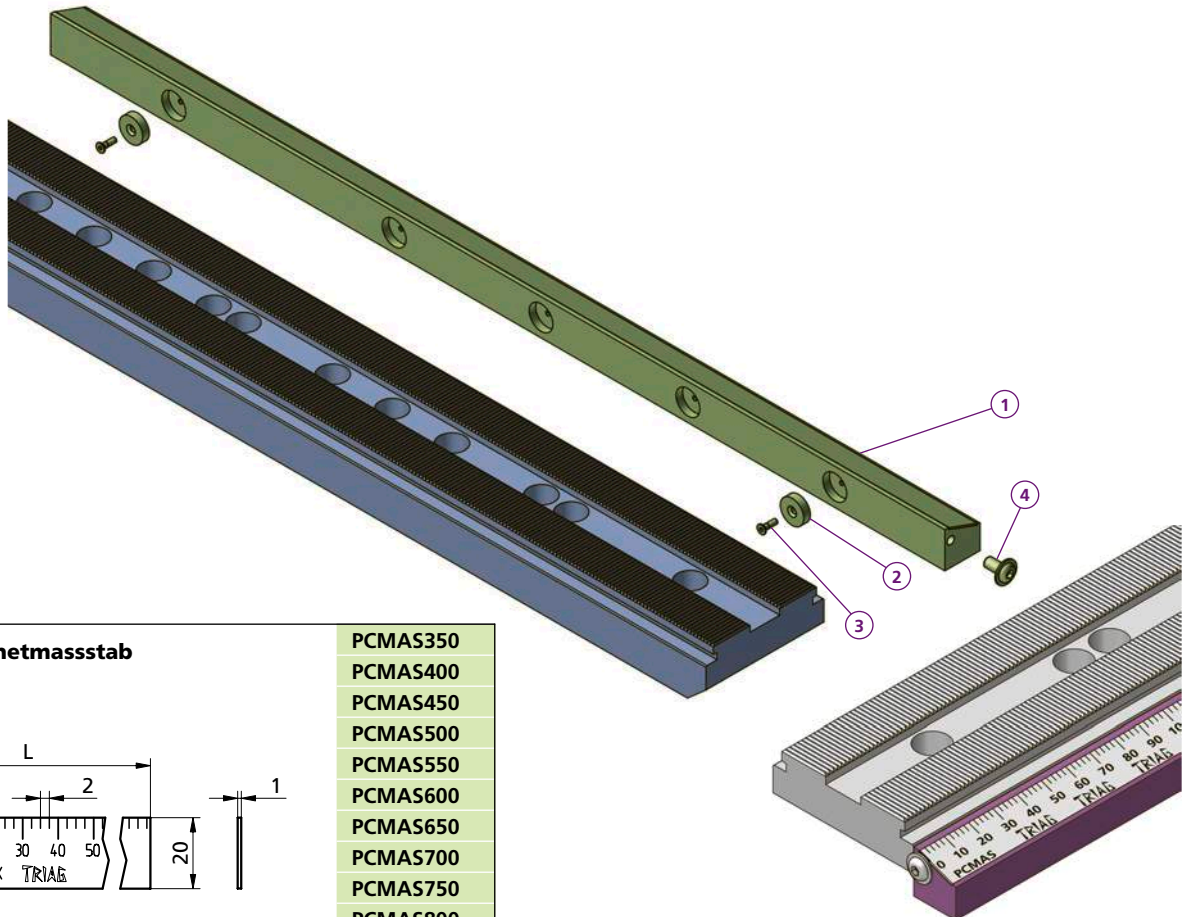
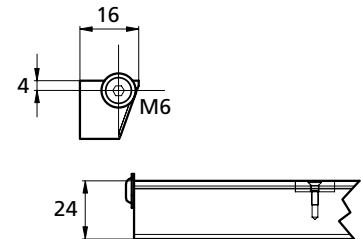
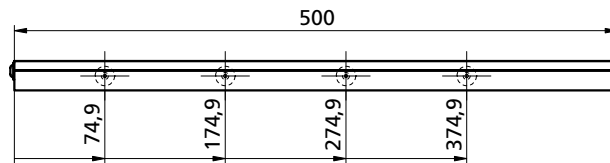

Alu - Magnetmasstab Alu scale

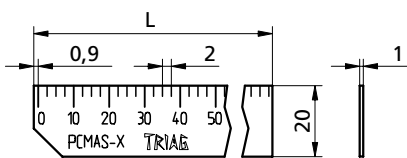

- PCMAS350
- PCMAS400
- PCMAS450
- PCMAS500
- PCMAS550
- PCMAS600
- PCMAS650
- PCMAS700
- PCMAS750
- PCMAS800

Bestellbeispiel / Ordering example : PCMAS800ML

Separat bestellen / Order separately

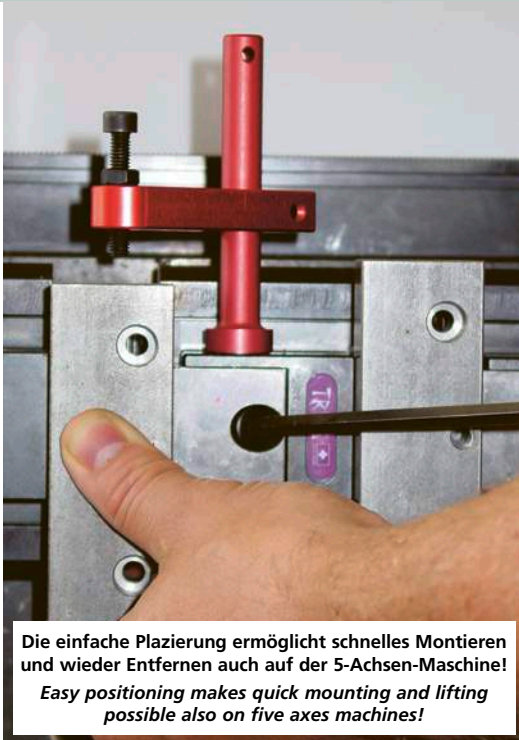

Die einfache Platzierung ermöglicht schnelles Montieren und wieder Entfernen auch auf der 5-Achsen-Maschine!
Easy positioning makes quick mounting and lifting possible also on five axes machines!

Die 3 Sicherheitsstufen:

Durch seine rote Farbe ist der Anschlag besser sichtbar, was das Risiko vermindert, dass er in der Maschine vergessen wird.

Die Bohrung dient zum Befestigen einer Schnur am Handgelenk oder ausserhalb der Maschine.

Dank dem Magnet ist der Anschlag auf allen magnetischen Materialien auf minimalem Platz einsetzbar, bei Kollision wird er weggedrückt. Es entstehen so keine teuren Werkzeugbrüche oder Maschinendefekte.

The 3 safety levels:

Because of its red color, the buffer is better visible. So the risk of forgetting the device in the machine is diminished.

The drilling serves to fasten a cord around the wrist or outside the machine.

Its magnet makes the buffer applicable on all magnetic materials on minimum space, in case of collision it gets pressed away, so there won't be any expensive breaking of tools or machines.

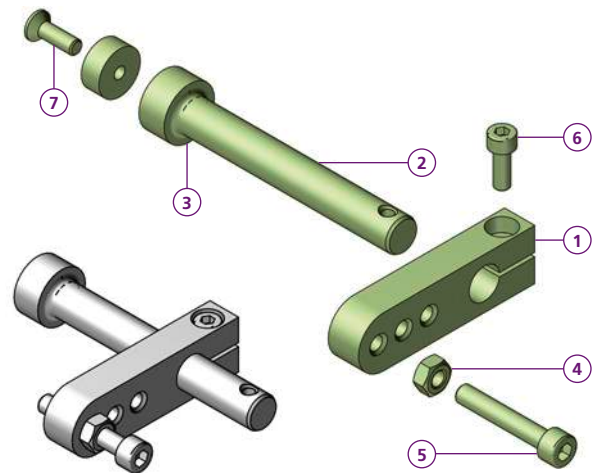
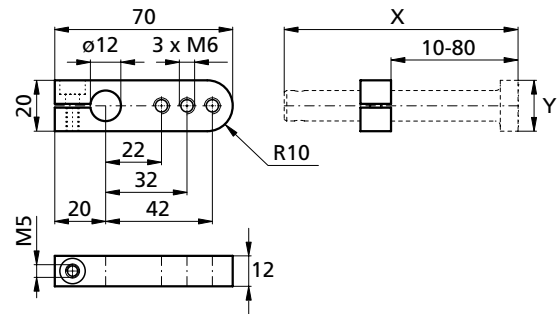

Haltekraft / Holding force	Haltekraft / Holding force
45N = 4,5daN (~4,5 kg)	80N = 8daN (~8 kg)
FAUM2070	FAUM2070S
1 1x FA2070	1 1x FA2070
2 1x FAD2092	2 1x FAD2092S
3 2x MG1645	3 1x MG2570
4 2x M6ISO4032	4 1x M6ISO4032
5 1x M6X35ISO4762	5 1x M6X35ISO4762
6 1x M5X14ISO4762	6 1x M5X14ISO4762
7 1x M3X8ISO10642	7 1x M5X16ISO10642
X = 92	X = 95
Y = ø 20	Y = ø 25
kg ~0,084	kg ~0,1

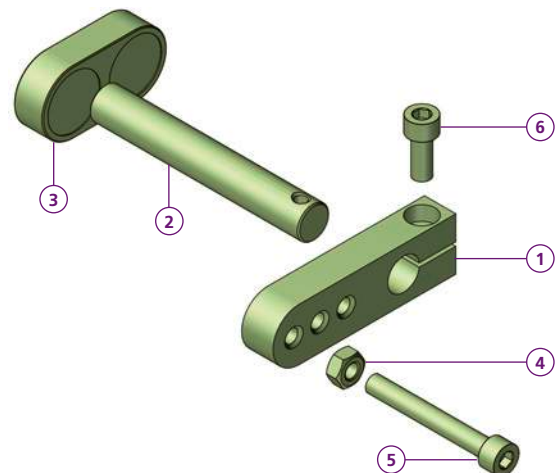
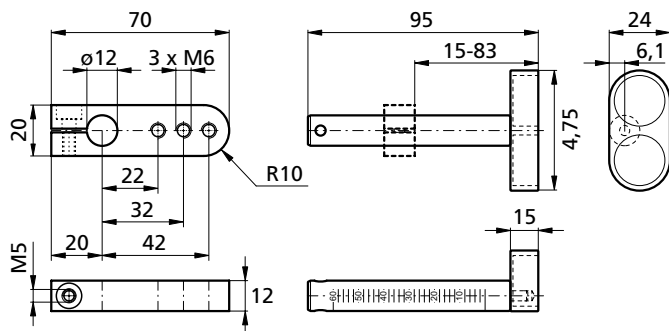

Haltekraft / Holding force
120N = 12daN (~12 kg)
FAUM2070US
1 1x FA2070
2 1x FAD1280
3 1x FUSSUS
4 1x M6ISO4032
5 1x M6X35ISO4762
6 1x M5X14ISO4762
kg ~0,146

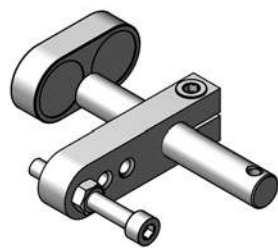

Bestellbeispiel Ordering example : FAUM2070US

Fräsanschlag / Milling buffer

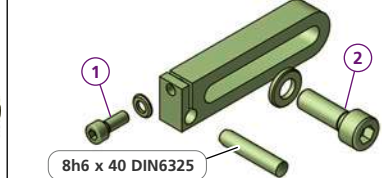
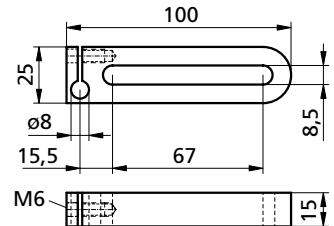
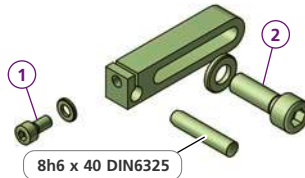
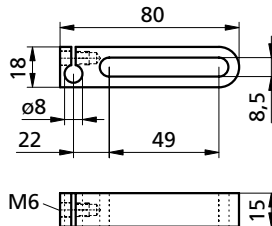
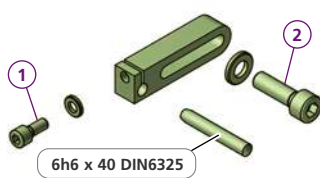
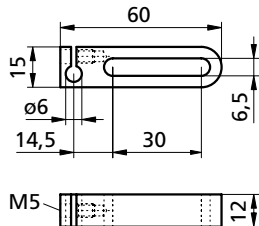
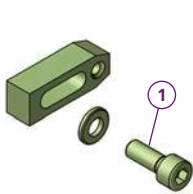
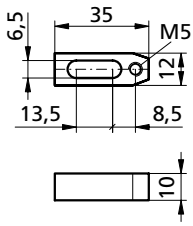

FA1240
 1 1x M6X18ISO4762
 kg ~0,024

FA1260
 1 1x M5X12ISO4762
 2 1x M6X20ISO4762
 kg ~0,07

FA1280
 1 1x M6X12ISO4762
 2 1x M8X25ISO4762
 kg ~0,014

FA12100
 1 1x M6X16ISO4762
 2 1x M8X25ISO4762
 kg ~0,022

**Distanzbüchse zu Fräsanschlag
 Spacers for workpiece stop**

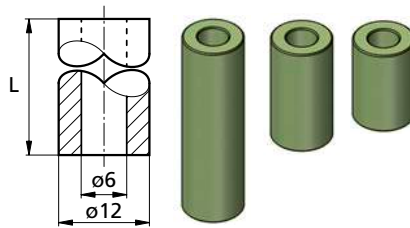
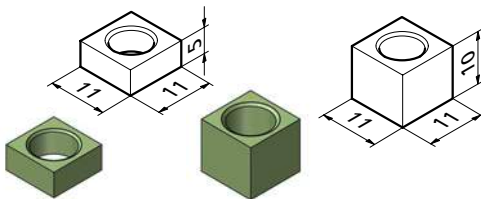

FAD12018	L	kg
FAD12018	18	~0,012
FAD12023	23	~0,016
FAD12040	40	~0,026

CCD005

CCD010

FAD12018
 FAD12023
 FAD12040

**Positionierstift (spreizbar)
 Locating pin (expandable)**

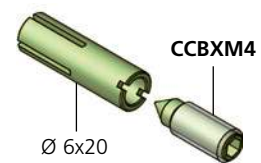

CCBX0802

Druckstift / Gripping pins

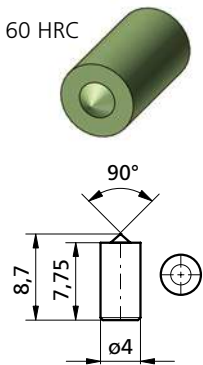

DS0402-90°

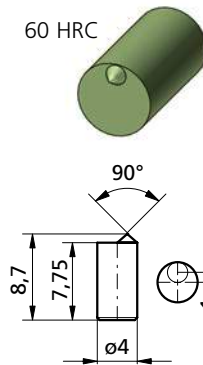

DSE0402-60°

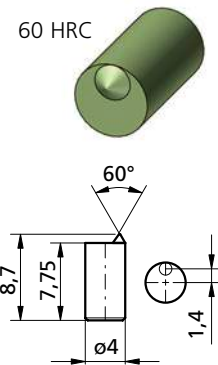

DSE0402-90°

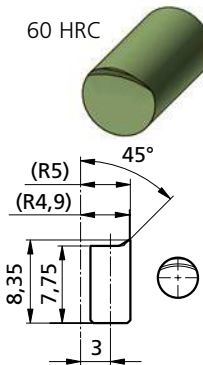

DSE0402-BS

**Einbauanleitung
 Installation guide**

Bohrung vorbereiten
 Preparation of drill-hole
 Einkleben mit / Glue with
 Loctite 641

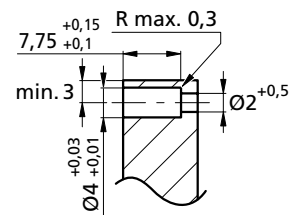

**Hartmetalldruckstück
 Carbide gripper**

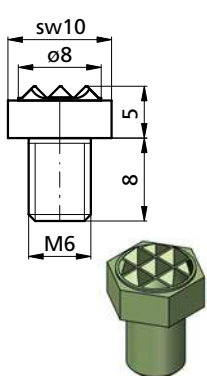

CCHMR

**Prägespanschraube
 Stamping roll screw**

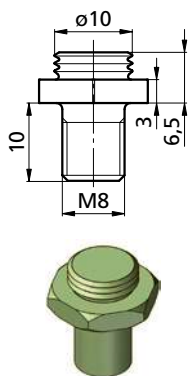

PRG1003M8

**Bohrbild
 Hole pattern**

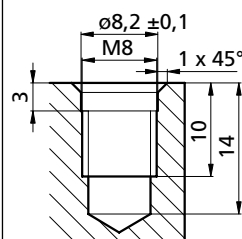

**Kugeldruckstück
 Gripper**

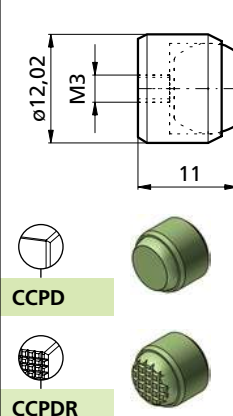

CCPDR

**Ausrichtzapfen für T-Nuten
 Alignment-pins for t-slots**

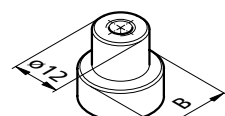

TWADAPT	B
TWADAPT10	10
TWADAPT12	12
TWADAPT14	14
TWADAPT16	16
TWADAPT18	18
TWADAPT20	20
TWADAPT22	22



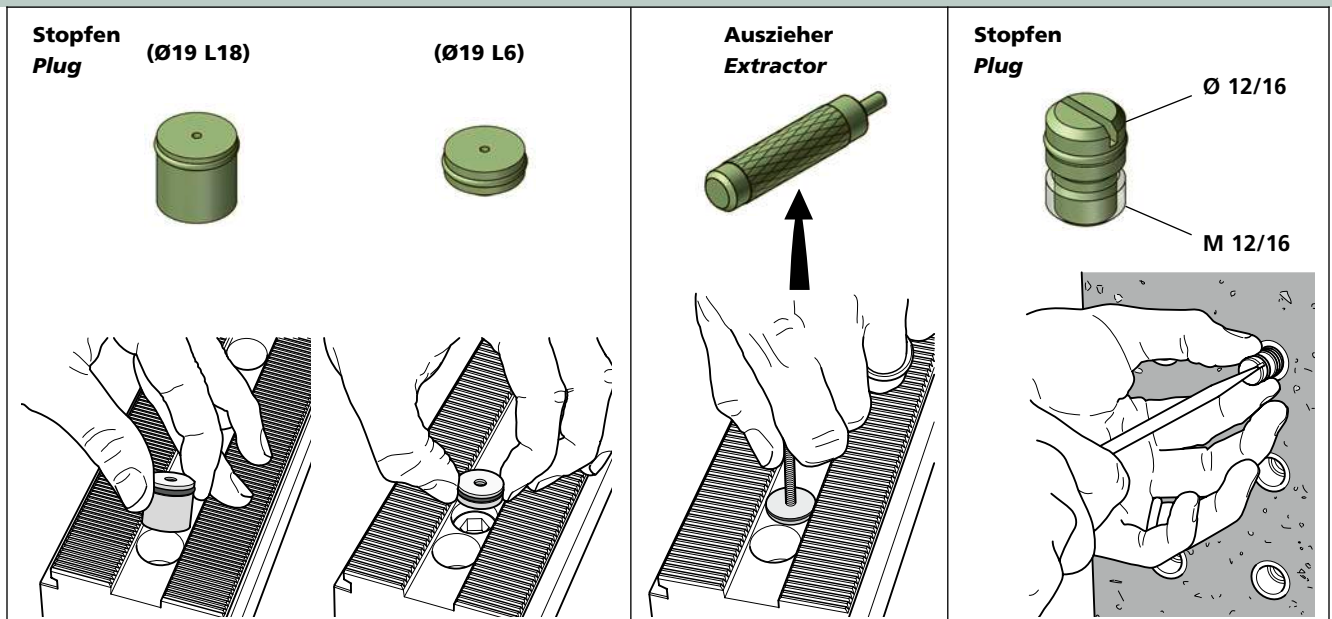

PCPF16L18 PCPF16L6 PCAZM3 CCPF12ALU / CCPF16ALU

Spannschrauben (Nitriert)
Clamping screw (Nitrided)

für/for kg

M8x20ISO4762NQ	B60	~0,012
M10x25ISO4762NQ	B80	~0,024

Passschrauben / Fitting screw

M5 / M6 / M12 / M16

Reduktionshülsen für Rasterplatte
Reduction sleeve for grid plate

RD18M1612M12 RD16M1612M12 RD16M12

	D	G	L	B	K	sw	Nm	kg
MS50	5 f7	M5	17	9	5	4	4,5	~0,004
MS60	6 f7	M6	17	9	6	5	8	~0,006
TWPAS1227	12g7	M12	27	14	12	10	60	~0,038
TWPAS1232	12g7	M12	32	19	12	10	60	~0,042
TWPAS1240	12g7	M12	40	20	12	10	60	~0,048
TWPAS1250	12g7	M12	50	30	12	10	60	~0,058
TWPAS16055	16 f7	M16	55	30	15,8	14	150	~0,120

T-Nuten Steine / T-slot nuts

d	α	kg
SM1135 M06X08	~0,012	
SM1135 M06X10	~0,012	
SM1135 M08X10	~0,012	
SM1135 M08X12	~0,022	
SM1135 M08X14	~0,04	
SM1135 M10X12	~0,02	
SM1135 M10X14	~0,038	
SM1135 M12X14	~0,045	
SM1135 M12X16	~0,045	
SM1135 M12X18	~0,078	
SM1135 M12X20	~0,13	
SM1135 M14X16	~0,188	
SM1135 M14X18	~0,188	
SM1135 M16X18	~0,068	
SM1135 M16X20	~0,11	
SM1135 M18X20	~0,11	
SM1135 M18X22	~0,15	
SM1135 M18X22	~0,15	
SM1135 M20X22	~0,15	
SM1135 M20X24	~0,23	
SM1135 M24X28	~0,31	

Bohrbüchsen
Position case

	L	D	d
CCBUE121812	12	18,0	12,0
CCBUE1218512	12	18,5	12,0
CCBUE121912	12	19,0	12,0
CCBUE162616	16	26,0	16,0

Nutensteine, flach
Low slot tenons

Einsatzgehärtet, brüniert, geschliffen
Case-hardened, blackened, ground

	b	H	L	d1	d2	t	inkl. Schrauben incl. screws	kg
SM1136- 12	8	20	5,5	10	5,3		M5x12	~0,019
SM1136- 14							M6x16	~0,021
SM1136- 16							M6x16	~0,026
SM1136- 18	10	22	6,6	11	6,3		M6x16	~0,03
SM1136- 20							M6x16	~0,034

Nutensteine, fest
Fixed slot tenons

Einsatzgehärtet, brüniert, geschliffen
Case-hardened, blackened, ground

	H	L	b	Nutenmass slot size	inkl. Schrauben incl. screws	kg
NT2012	10	22	12	20	M6x10	~0,022
NT2014		14	20	M6x10	~0,026	
NT2016		25	16	20	M6x10	~0,028
NT2018		18	20	M6x10	~0,03	
NT2022	12	32	22	20	M6x12	~0,05
NT2024		24	20	M6x12	~0,055	

Pneumatikschrauber Set
Pneumatic screwdrivers set

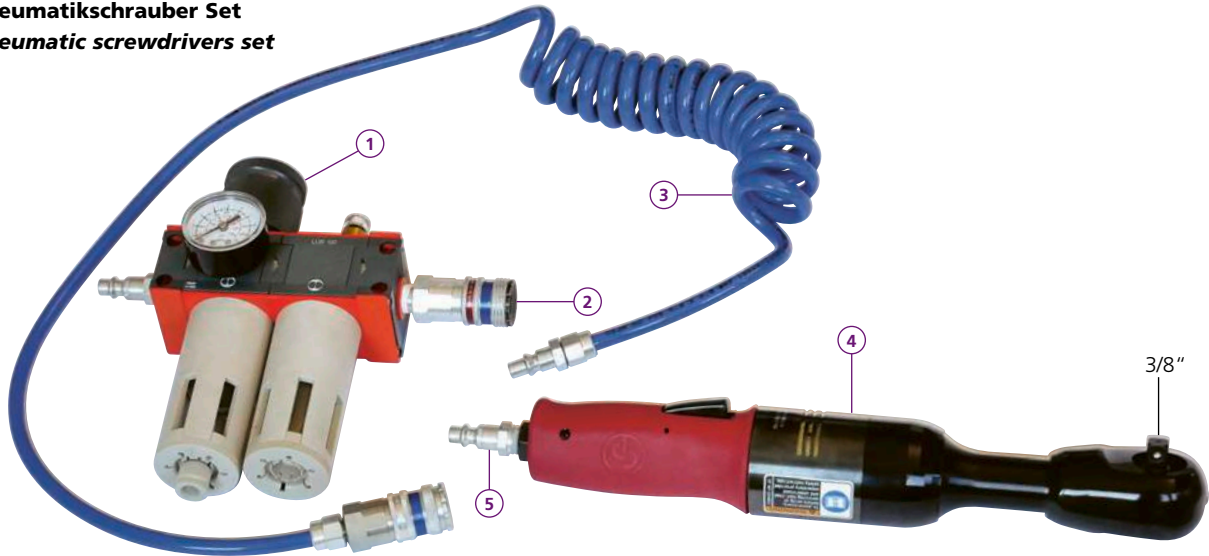

RP9431SET

- ① 1x P1H-200-M3QG
 - ② 1x 103002152 (SERIE 300) 1/4"
 - ③ 1x 199589977 (5 x 8 mm, 300, 2 m)
 - ④ 1x RP9431
 - ⑤ 2x 103105152 1/4"
- kg ~1,5

Drehmomenttabelle / Torque table	Druck / Compression (bar)	Nm
	6	50
Schlauchdurchmesser 8 mm	5,5	45
Luftverbrauch 2,5 L Sek	5	40
	4,5	35
Hose diameters 8 mm	4	30
Air consumption 2,5 L sec	3,5	25
	3	20

mit Feder gehalten, nicht magnetisch
 spring locked, not magnetic



mit Feder gehalten, nicht magnetisch
 spring locked, not magnetic



siehe Video
 see video

Triag Bit

Triag Bitburr

Luftpistolen Gummiadapter
Air gun rubber adapter

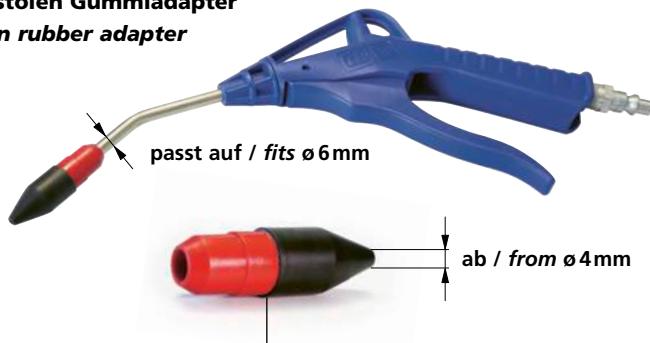

ARA14

Magnethalter
Magnetic holder

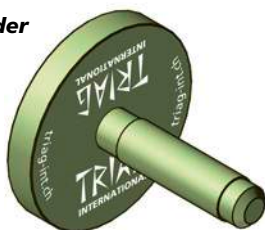

Einsatz für Triva Bit
Insert for Triva Bit



Smiley

BitT

Einsätze zu Bitburr
Inserts for Bitburr



TC10



BitF63 Ø 6,3-90°



BIT-KH



BitF104 Ø 10,4-90°



BIT-BF



BitF165 Ø 16,5-90°

Bestellbeispiel / Ordering example: **RP9431SET**

Drehmomentschlüssel
Torque wrench



SL3 20-200 Nm (1/2")

Steckschlüsseleinsatz
Socket wrench insert

Torx Sechskanteinsatz
Hexagon insert

NUSS3/8"TX30E14	für / for	MCZ, ZSX, ZSM, ZSB, PCZ
NUSS1/4"4.5MM	4,5 mm	für / for MCZ40L30,
NUSS1/4"5.5MM	5,5 mm	UB5AXSET3, PCZ80L40PRG62

Sechskantstifteinsatz
Hexagonal socket wrench

(L) lang (L) long (LK) lang mit Kugelkopf (LK) long with ball head

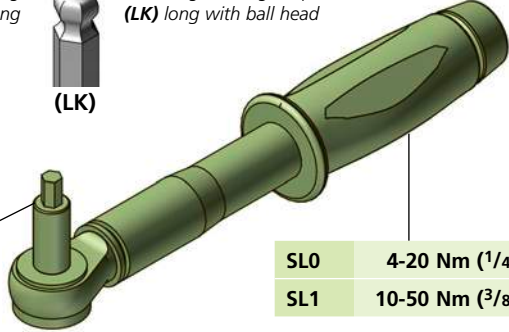

SL0 4-20 Nm (1/4")
SL1 10-50 Nm (3/8")

NUSS1/4"4MM	4 mm	NUSS3/8"6MM	
NUSS1/4"5MM	5 mm	NUSS3/8"6MML	6 mm
NUSS1/4"6MM	6 mm	NUSS3/8"6MMLK	
NUSS1/4"8MM	8 mm	NUSS3/8"8MM	
		NUSS3/8"8MML	8 mm
		NUSS3/8"8MMLK	
NUSS3/8"5MM		NUSS3/8"10MM	
NUSS3/8"5MML	5 mm	NUSS3/8"10MML	10 mm
NUSS3/8"5MMLK		NUSS3/8"10MMLK	

Spannschlüssel
Clamping wrench



02613160	4 mm
02613164	5 mm
02613168	6 mm
02613172	8 mm
02613176	10 mm

Langer Spannschlüssel
Long clamping wrench

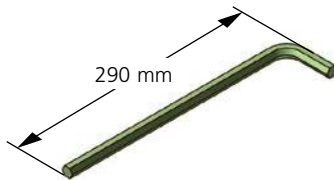

290 mm

ISL10	sw = 10 mm
ISL14	sw = 14 mm

Sechskantstifteinsatz
Hexagonal socket wrench



NUSS1/2"8MM	NUSS1/2"14MML
NUSS1/2"10MM	
NUSS1/2"14MM	



AD-BIT-1/4-1/4
AD-BIT-1/4-3/8

Messingdrahtbürste
Brass wire brush

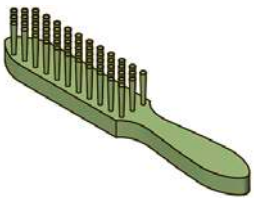

PCMB4



Triag Ei

3D Mess-Gelenkstativ
Articulated indicator holders



Aktionsradius / Operating radius

MGMS08130	130 mm
MGSS08130	130 mm
MGMS08280	280 mm

Index

- 5AXMCZ100-45-3 136
5AXMCZ100-45-3H 136
5AXMCZ100-45-4 134
5AXMCZ100-45-4H 135
5AXMCZ100-45-6 136
5AXMCZ100-45-8 135
5AXMCZ100-45-12 135
5AXMCZ100-90-4 134
5AXZ5X35-3 154
0130001 324
0130002 324
243834.0083300 290
243834.0103300 290
243834.0123300 290
0500205 326
0520000 324
0700100 314, 315, 316, 317,
318, 324
0700102 314, 315, 316, 317,
324
0700200 324
0802000-SET 322
0910000 323, 326
0910001 314, 315, 316, 317,
318, 323
0910080 323
0920000 314, 315, 316, 317,
318, 319, 323, 326
0930000 323
0940200-SET 323
0940300-SET 323
0940800 323
0940800-SET 323
0941000 321, 323
0941010 324
1110100 314, 315, 316, 317,
321, 324
1110100S 324
1110100SP 324
1111003 314, 315, 316, 317,
318, 319, 323, 326
1120100 314, 315, 316, 317,
318, 319, 321, 324
1120100M 324
1130000 324
02613160 340
02613164 340
02613168 340
02613172 340
02613176 340
10100024 323
- A**
AA5X115-50 228
AA5X125-50 229
AA5X125-50VB 231
AA5X150-50 230
AAND115-50 228
AAND125-50 229
AAND150-50 230
AC1505520W 233
AC1505540W 233
ACB4050400 222
ACB4050450 222
ACB4050500 222
ACB4050550 222
ACB4050600 222
ACB4050650 222
ACB4050700 222
ACB4050750 222
ACB4050800 222
ACBS1646 233
- ACD005 223, 224, 225, 227
ACES6540 232
ACES10040H25W 232
ACES10240H07 232
ACGGB103048 227, 231
ACPB103048 227, 231
ACU21124 232
ACU36124 232
ACU41124 232
ACU46124 232
ACUH21-124 233
ACWB103048 227, 231
ACZ56540 232
ADAPT6-12 317, 324
AD-BIT-1/4-1/4 340
AD-BIT-1/4-3/8 340
ARA14 339
AS1F150N50-80 226
AS1R150N50-80 226
AS2F115N50-80 223
AS2F125N50-80 224
AS2F150N50-80 225
AS2R115N50-80 223
AS2R125N50-80 224
AS2R150N50-80 225
AS2X125L50-105 227
AS25X115N50-80 223
AS25X125L50-105 227
AS25X125N50-80 224
AS25X150N50-80 225
AS35 47, 146
AS60 47, 146
AS80 47, 146
- B**
B01 182, 183, 184, 185
B02 182, 183, 184, 185
B03 182, 183, 184, 185
B04 182, 183, 184, 185
B05 182, 183, 184, 185
B05R 182, 183, 184, 185
B07 178, 179, 180
B08 178, 179, 180
B09 178, 179, 180
B09+2 178, 179, 180
B09+5 178, 179, 180
B13 61, 71, 181
B14 61, 71, 181
B15 61, 71, 181
B16 61, 71, 181
B20 60, 186
B21 60, 186
B22 60, 186
B26 62, 187
B27 62, 187
B28 62, 187
B30 197
B31 197
B32 197
B33 197
B36 190
B37 190
B38 190
B45 63, 72
B46 63, 72
B47 63, 72
B47HM 63, 72
B51 198, 201
B52 198, 201
B53 198, 201
B54 198, 201
B55 198, 201
- B58 64, 73, 188, 189, 191, 192,
194, 195
B60 64, 73, 188, 189, 191, 192,
194, 195, 338
B61 64, 73, 188, 189, 191, 192,
194, 195
B62 64, 73, 188, 189, 191, 192,
194, 195
B62HM 64, 73, 188, 189, 191,
192, 194, 195
B65 64, 73, 188, 189, 191, 192,
194, 195
B66 64, 73, 188, 189, 191, 192,
194, 195
B67 64, 73, 188, 189, 191, 192,
194, 195
B68 64, 73, 188, 189, 191, 192,
194, 195
B69 64, 73, 188, 192
B77 64, 73, 188, 189, 191, 192,
194, 195
B78 198, 201
B79F 64, 73, 188, 189, 191,
192, 194, 195
B79R 64, 73, 188, 189, 191,
192, 194, 195
B80 65, 66, 67, 223, 224, 225,
226, 226
B80N 65, 66, 67, 223, 224,
225, 226
B81 65, 66, 67, 223, 224, 225,
226
B82 65, 66, 67, 223, 224, 225,
226
B82HM 65, 66, 67, 223, 224,
225, 226
B82L33 65, 66, 67, 223, 224,
225, 226
B83 65, 66, 67, 223, 224, 225,
226
B84 65, 66, 67, 223, 224, 225,
226
B89F 65, 66, 67, 223, 224, 225,
226
B89R 65, 66, 67, 223, 224, 225,
226
B90 68
B90F78 69
B90R78 69
B90W78 69
B91 68
B92 68
B93 68
B94 68
B95 70, 193
B96 70, 193
B97 70, 193
B98 70, 193
B99 70, 193
B105 77, 79, 80, 81, 85, 200,
227
B105-15 85
B105H20 82
B105P 85
B106 85
B106H20 82
B106P 85
B107 85
B107H20 82
B107P 85
B108 85
B108P 85
- B110 79, 84
B110H20 82
B110P 84
B110P-PRGM8 84
B111 84
B111H20 82
B111P 84
B112 84
B112E 84
B112EP 84
B112H20 82
B112HG 84
B112P 84
B113 84
B113P 84
B115 74, 85, 199
B115P 85
B116P 85
B117P 84
B120 75, 84
B120P 80, 84
B122P 78
B123P 76
B130H20P 83
B131H20P 83
B132H20P 83
B140 85
B140P 85
B141 85
B141P 85
B150 196
B151 196
B170 128
B172 128, 130
B172-MB 130
B173-26 129
B173-45 129
B173-64 129
B173-83 129
B173-102 129
B173-MB 130
B173SET 129
B175-26 128
B175-45 128
B175-64 128
B175-83 128
B175-102 128
B175-121 128, 135
B175-MB 130
B175SET 128
B176-80 129
B190-13 116
B190-22 116
B190-31 116
B190W6-40 117
B190W10-40 117
B190W20-40 117
B190W30-40 117
B210-62 123, 124
B212W11-60 123, 124
B212W20-60 123, 124
B222 156
B240UPRG 149
B242W50-100 149
B310 105
B311 105
B312 105
B313 105
BIT-BF 339
BitF63 339
BitF104 339
BitF165 339

Index

- BIT-KH 339
BitT 339
BL-SET 108
- C**
CC8011 205
CC8021 205
CC8025 205
CC8026 205
CC8030 205
CC8040 205
CC8041 205
CC8050 205
CC8050V90 205
CC8050V120 205
CC8060 205
CC8060R 205
CC8070 205
CC8210 205
CC8211 205
CC8220 205
CCA21050 204
CCBO0801 110, 190, 191, 194,
201, 204, 292
CCBO0802 186, 187, 188, 189,
197, 198, 204
CCBO0803 190, 192, 204
CCBUE121812 338
CCBUE121912 338
CCBUE162616 338
CCBUE1218512 338
CCBX0802 204, 337
CCBXM4 204, 337
CCBXSK 204
CCD004 186, 187, 188, 189,
191, 192, 193, 197, 198,
201
CCD005 337
CCD007 190
CCD010 337
CCHMR 51, 64, 65, 66, 67, 68,
69, 70, 73, 188, 189, 191,
192, 193, 194, 195, 205,
223, 224, 225, 226
CCPD 337
CCPDR 64, 73, 188, 189, 191,
192, 194, 195, 337
CCPF12ALU 338
CCPF16ALU 338
CCU15026 204
CCU15027 204
CCU15080 204
CCU15081 204
CCU15082 204
CCU15083 204
CCU20026 204
CCU20027 204
CCU20080 204
CCU20081 204
CCU20082 204
CCU20083 204
CCU25026 204
CCU25027 204
CCU25080 204
CCU25081 204
CCU25082 204
CCU25083 204
CCU27580 204
CCU27581 204
CCU27582 204
CCU27583 204
CCU30026 204
CCU30027 204
CCU30039 204
CCU30080 204
CCU30081 204
CCU32526 204
CCU32527 204
CCU35039 204
CCU35080 204
CCU40039 204
CCU40080 204
CCU45039 204
CCU45080 204
- D**
DS0402-90° 337
DSE0402-60° 205, 337
DSE0402-90° 337
DSE0402-BS 337
- E**
ER-033400 300
ER-033402 299
ER-033800 299, 300
ER-036800 300
ER-036802 299
ER-038000 299, 300
ER-039200 299, 300
ER-039201 299, 300
EROWA ITS-Palette 119
EROWA MTS 297
- F**
FA1240 337
FA1260 337
FA1280 337
FA12100 337
FAD12018 337
FAD12023 337
FAD12040 337
FAUM2070 336
FAUM2070S 336
FAUM2070US 336
FED0318 71
FED0418 60, 62, 186, 187, 197
FED0618 63, 64, 65, 66, 67, 68,
69, 70, 72, 73, 110, 188,
189, 190, 191, 192, 193,
194, 195, 197, 198, 201,
223, 224, 225, 226, 227,
228, 229, 230, 231
FED02813 182, 183, 184, 185
FED03018 61, 178, 179, 180,
181
- G**
GEWST6L14 196
GPL30040 274
GPL40040 274
GPL45040 274
GPL50040 274
GPL63040 274
GPL80040 274
GPL50040040 274
- I**
ISL10 102, 340
ISL14 340
- M**
M3X6ISO4762 61, 180, 181
M3X8ISO4762 205
M3X10ISO4762 61, 180, 181,
335
M3X25ISO4762 197, 198, 201
M4X8ISO4762 159
M4X10ISO4762 322
M5X8ISO4762 112, 190
M5X8ISO7380 157, 158, 159,
186, 187, 188, 189, 191,
192, 193, 197, 198, 201
M5X10DIN6912 182, 183, 184,
185
M5X10DIN7991 200
M5X10ISO4762 60, 61, 62, 63,
64, 65, 66, 67, 68, 69, 70,
71, 72, 73, 74, 75, 76, 77,
78, 79, 81, 82, 83, 90, 91
M5X10ISO7380-1 223, 224,
225, 226, 227, 228, 229,
230, 231
M5X12ISO4762 178, 179, 180,
205, 337
M5X12ISO7380 186, 187, 188,
189, 190, 191, 192, 193,
197, 198, 201, 205
M5X14ISO4762 60, 62, 63, 64,
65, 66, 67, 68, 69, 70, 73,
74, 75, 76, 77, 78, 79, 80,
81, 82, 83, 182, 183, 184,
185, 336
M5X14ISO7380-1 223, 224,
225, 226, 227
M5X16DIN912 122, 152
M5X16ISO4026 73
M5X16ISO4762 68, 72, 141,
175, 176, 178
M5X16ISO7380 190
M5X18ISO4762 205
M5X20BN1362 96
M5X20BN1392 108
M5X20ISO4762 205
M5X20ISO7380 231
M5X22ISO4762 112
M5X25ISO4762 205
M5X85DIN912 109, 110, 112
M6X8ISO7380 47, 48, 50, 51,
60, 61, 62, 63, 64, 65, 66,
67, 68, 69, 70, 71, 72, 73,
74, 75, 76, 77, 78, 79, 80,
81, 82, 83, 90, 91, 93, 94,
95, 96, 98, 100, 101, 102,
105, 108, 146, 150, 318,
319
M6X10ISO4762 141, 142, 146,
150
M6X12BN5128 335
M6X12DIN912 43
M6X12ISO4762 43, 322, 337
M6X14ISO10642 104
M6X16ISO4762 61, 71, 181,
337
M6X16ISO7380 126
M6X18DIN912 160
M6X18ISO4762 322, 337
M6X20ISO4762 60, 186, 337
M6X25ISO4762 177, 322
M6X35ISO4762 157, 317, 336
M6X40ISO4762 158
M6X45ISO4762 98, 314, 315,
316
M6X60ISO4762 158
M8X16ISO4762 157, 158
M8X20ISO4762 62, 63, 64, 72,
73, 186, 187, 188, 189,
190, 191, 192, 194, 195,
197, 198, 199, 201, 233
M8x20ISO4762NQ 338
M8X22DIN7991 175, 176
M8X25ISO4762 46, 200, 202,
203, 337
M8X28ISO4762 74, 75, 76,
78, 80
M8X30ISO4762 76, 77, 79, 81,
188, 192, 199, 200, 203,
227
M8X35DIN912 190
M8X35ISO4762 82, 83, 191,
194, 201
M8X50ISO4762 98
M8X55DIN912 190
M8X55ISO4762 98, 192
M10X12ISO4027 314, 315, 316,
317, 318, 323
M10X22ISO4762 108
M10X25ISO4762 65, 66, 67,
68, 69, 70, 193, 223, 224,
225, 226
M10x25ISO4762NQ 338
M10X30ISO4762 96
M12X20DIN6912 119
M12X25DIN7984 275
M12X30DIN7984 232
M12X30ISO4762 228, 229, 230,
231
M12X35ISO4762 118, 119, 193
M12X40ISO4762 46, 50
M12X45ISO4762 43, 46
M12X50ISO4762 228, 229, 230,
231
M16X45ISO4762 223, 224, 225,
227, 228, 229, 230, 231
M16X55ISO4762 227, 231
M16X65ISO4762 228, 229, 230
M16X70ISO4762 223, 224, 225,
226, 228, 229, 230
MA248650R50 269
MA248655R50 269
MA248660R50 269
MA248665R50 269
MA301265R50-8-2 270
MA301270R50-8-2 270
MA301275R50-8-2 270
MABD501550 275
MABD502050 275
MABD502550 275
MABD503050 275
MAND38-14PRG 176
MAND38-14PRG6 176
MAND58-14PRG 141, 154, 175
MAND58-14PRG6 175
MANF38-14F25 176
MANF38-14RF 176
MANF38-14W25 176
MANF58-14F25 176
MANF58-14RF 176
MANF58-14W25 154, 176
MCD004 61, 180, 181
MCU11037 61, 180, 181, 204
MCU15037 61, 180, 181, 204
MCU18037 61, 180, 181, 204
MCU20037 61, 180, 181, 204
MCU22537 61, 180, 181, 204
MCZ40L30 115, 117
MCZ40L30E 117
MCZ40L30PRG13 116
MCZ40L30PRG22 116

Index

- MCZ40L30PRG31 116
MCZ40L30W6 116
MCZ40L30W10 116
MCZ40L30W20 116
MCZ40L30W30 116
MCZ80L32PRG62 123
MCZ100L50 126, 127, 133,
134, 135
MGMS08130 340
MGMS08280 340
MGSS081040130 340
MK200970R50 251
MK300950R50 251
MK300955R50 251
MK300960R50 251
MK300965R50 251
MK300970R50 251
MK300975R50 251
MK301850R50 253
MK301855R50 253
MK301860R50 253
MK301865R50 253
MK301870R50 253
MK301875R50 253
MK321075R100 254
MK321080R100 254
MK321085R100 254
MK321090R100 254
MK321095R100 254
MK321875R100 254
MK321880R100 254
MK321885R100 254
MK321890R100 254
MK321895R100 254
MK350865R50 252
MK350870R50 252
MK350875R50 252
MK350880R50 252
MK350885R50 252
MK350890R50 252
MK350895R50 252
MK351865R50 255
MK351870R50 255
MK351875R50 255
MK351880R50 255
MK351885R50 255
MK351890R50 255
MK351895R50 255
MK401865R50 256
MK401870R50 256
MK401875R50 256
MK401880R50 256
MK401885R50 256
MK401890R50 256
MK401895R50 256
MQ161630R50 257
MQ161635R50 257
MQ161640R50 257
MQ161645R50 257
MQ161650R50 257
MQ202040R50 258
MQ202045R50 258
MQ202050R50 258
MQ202055R50 258
MQ202060R50 258
MQ202065R50 258
MQ202070R50 258
MQ242450R50 258
MQ242455R50 258
MQ242460R50 258
MQ242465R50 258
MQ252560R50 259
MQ252565R50 259
MQ252570R50 259
MQ252575R50 259
MQ252580R50 259
MQ303050R50 259
MQ303055R50 259
MQ303060R50 259
MQ303065R50 259
MQ303070R50 259
MQ303075R50 259
MQ353565R50 260
MQ353570R50 260
MQ353575R50 260
MQ353580R50 260
MQ353585R50 260
MQ353590R50 260
MQ353595R50 260
MQ404065R50 260
MQ404070R50 260
MQ404075R50 260
MQ404080R50 260
MQ404085R50 260
MQ404090R50 260
MQ404095R50 260
MQ424275R40 261
MQ424280R40 261
MQ424285R40 261
MQ424290R40 261
MQ424295R40 261
MR1F30N23-07 178
MR301550R50 262
MR301555R50 262
MR301560R50 262
MR301565R50 262
MR401245R50 262
MR401250R50 262
MR401255R50 262
MR401260R50 262
MR402050R50 263
MR402055R50 263
MR402060R50 263
MR402065R50 263
MR402070R50 263
MR402075R50 263
MR502060R50-2 264
MR502060R50-4 264
MR502065R50-2 264
MR502065R50-4 264
MR502070R50-2 264
MR502070R50-4 264
MR502075R50-2 264
MR502075R50-4 264
MR502080R50-2 264
MR502080R50-4 264
MR502085R50-2 264
MR502085R50-4 264
MR502090R50-2 264
MR502090R50-4 264
MR502095R50-2 264
MR502095R50-4 264
MR602060R50-2 265
MR602060R50-4 265
MR602065R50-2 265
MR602065R50-4 265
MR602070R50-2 265
MR602070R50-4 265
MR602075R50-2 265
MR602075R50-4 265
MR602080R50-2 265
MR602080R50-4 265
MR602085R50-2 265
MR602085R50-4 265
MR602090R50-2 265
MR602090R50-4 265
MR602095R50-2 265
MR602095R50-4 265
MR633075R40 266
MR633080R40 266
MR633090R40 266
MR633095R40 266
MR701550R50 267
MR701555R50 267
MR701560R50 267
MR701565R50 267
MR701570R50 267
MR701575R50 267
MS1F22N40-07 179
MS1F24N22-07 180
MS1F25N25-13 181
MS1F35L14-152 196
MS1F35N14-01 182
MS1F35N22-01 182
MS1F58L14W251 176
MS1P58L14PRG15 175
MS1R24N22-07 180
MS1R25N25-13 181
MS1R35L14-152 196
MS1R35N14-01 182
MS2F58L14W251 176
MS2F60N14-01 184
MS2P58L14PRG15 175
MS2X35N23-01 183
MS3F85N14-01 185
MS50 177, 180, 182, 183, 184,
185, 196, 338
MS60 102, 181, 338
MS321960R50 268
MS321965R50 268
MS321966R80 268
MS321970R50 268
MS321975R50 268
MS321980R50 268
MS402366R40 268
MS402366R50 268
MS402395R40 268
MS402395R50 268
MSK15W45 196
MST-TRI-600 273
MUB2817-H85 271
MUB2817-H100 271
MUB2817-H125 271
MUB3535H140 271
MV1F20L35BV1 101, 177
- ## N
- NT2012 338
NT2014 338
NT2016 338
NT2018 338
NT2022 338
NT2024 338
NUSS1/2"8MM 340
NUSS1/2"10MM 340
NUSS1/2"14MM 340
NUSS1/2"14MML 340
NUSS1/4"4.5MM 116, 118,
119, 122, 340
NUSS1/4"4MM 340
NUSS1/4"5.5MM , 123, 124,
126, 127, 141, 142, 144,
146, 148, 150, 97
NUSS1/4"5MM 340
NUSS1/4"6MM 340
NUSS1/4"8MM 340
- Nuss 1/4 - sw 4,5 122
NUSS3/8"5MM 340
NUSS3/8"5MML 340
NUSS3/8"5MMLK 340
NUSS3/8"6MM 340
NUSS3/8"6MML 340
NUSS3/8"6MMLK 340
NUSS3/8"8MM 340
NUSS3/8"8MML 340
NUSS3/8"8MMLK 340
NUSS3/8"10MM 340
NUSS3/8"10MML 340
NUSS3/8"10MMLK 340
NUSS3/8"TX30E14 126, 127,
142, 146, 150, 340
- ## O
- OP92BUE23 291
OP92BUE23ID 291
OPA1ID160 293
OPA1ID160R50 293
OPA1ID200 293
OPA1ID200R50 293
OPA1IDPCBD178 293
OPA4Q200 296
OPA4Q200R50 296
OPA182H63-RS 293
OPA2200 294
OPA2200R50 294
OPA3200 295
OPA3200R50 295
OPANS-8 301
OPB1ID 293
OPB4Q200 296
OPB4Q200R50ID-4 296
OPB2200R50 294
OPB2200R50ID-1 294
OPB2200R50ID-2 294
OPB3200ID-1 295
OPB3200R50 295
OPBM4Q100D184 286, 287
OPBM4Q100R50 283, 286, 287
OPBM4Q100R200 286, 287
OPEGB 292
OPEGBID 292
OPM3X80L75 286, 290
OPM3X100L82 286, 290
OPM3X125L88 286, 290
OPM25-15R50H28 286
OPM25-15RH40 286
OPMAD 286
OPMAW 289
OPMB12M12 283, 289
OPMB12M12S 289
OPMB12M12U 289
OPMB18M12 119, 289, 290
OPMB18M12S 289, 290
OPMB18M12U 289, 290
OPMBL 289
OPMBL-25 289
OPPAD 301
OPPD 301
OPRV 301
OPSKU 301
OPST-NI 304
OPUB150H44 286, 289
- ## P
- PA5X19-49F 86
PA5X19-49R 86
PA5X26-49F 86
PA5X26-49R 86

Index

- PA5X34-49F 86
PA5X34-49R 86
PA5X43-49F 88
PA5X43-49R 88
PA5X48-49F 88
PA5X48-49R 88
PA5X94-49F 89
PA5X94-49R 89
PA5X125-49F 89
PA5X125-49R 89
PAND19-49 86
PAND25-44 87
PAND26-49 86
PAND30-34RV12-35 97
PAND34-49 86
PAND43-49 88
PAND48-34 88
PAND48-34PRF-A1 90
PAND48-34PRG-A1 90
PAND48-49 88
PAND48-49PRF-A1 90
PAND48-49PRG-A1 90
PAND48-75 88
PAND58-34 88
PAND58-49 88
PAND60-19 157, 158, 159
PAND60-20.5UWB 159
PAND61-34 88
PAND61-34RV35-80 97
PAND68-34 88
PAND78-34 89
PAND78-34UPRG 92, 146
PAND78-34X50UPRG 92
PAND78-49 89
PAND78-49UPRG 92
PAND94-34 89
PAND94-34PRF-A1 90
PAND94-34PRG-A1 90
PAND94-34PRGV 91
PAND94-44 87
PAND94-49 89
PAND94-49PRF-A1 90
PAND94-49PRG-A1 90, 115,
139
PAND94-49PRGV 91
PAND120-49UPRG 92
PAND125-34PRG-A1 91
PAND125-49 89
PAND125-49PRG-A1 90
PAND150-34PRG-A1 91
PANF94-34PRGM8 92
PB2212L/6 202, 203
PC2280L40PRG62 124
PC48-34PRG 106
PC48-49PRG 106
PC94-34PRG 106
PC94-49PRG 106
PC4349 106
PC4349DS 107
PC4834 106
PC4834DS 107
PC4834RF 106
PC4849 106
PC4849DS 107
PC4849RF 106
PC9434-25PRGM8 106
PC9434DS 107
PC9434NVB 111
PC9434RF 106
PC9434V90-2 107
PC9434V120 107
PC9449DS 107
PC9449NVB 111
PC9449RF 106
PC9449V90-2 107
PC9449V120 107
PC9460 106
PC9460R 106
PC12549 106
PC12549DS 107
PC943425W 107
PC943430W 107
PC944930W 107
PC1254930W 107
PCAZM3 338
PCB250Q90H35 47
PCB850SET 46
PCB900SET 46
PCB950SET 46
PCB1000SET 46
PCB6090 42
PCB25200 42, 50
PCB25300 42, 50
PCB50207W25 52
PCB50207W27 52
PCB50320 42
PCB50320H60 43
PCB50320H80 44
PCB50350H80 44
PCB50400H80 44
PCB50450H80 44
PCB50500H80 44
PCB50550H80 44
PCB50600H80 44
PCB50650H80 44
PCB50700H80 44
PCB50750H80 44
PCB100350H60 43
PCB100400H60 43
PCB100500H60 43
PCB100600H60 43
PCB100650H60 43
PCB100690H60 43
PCB100850H60 43
PCB2550250 42
PCB2550250-OPM 286
PCB4050125 42
PCB4050125H80 44
PCB4050220W2 42
PCB4050250KP 46
PCB4050350 42
PCB4050400 42
PCB4050400KP 46
PCB4050450 42
PCB4050450KP 46
PCB4050500 42
PCB4050500KP 46
PCB4050550 42
PCB4050600 42
PCB4050650 42
PCB4050650KP 46
PCB4050700 42
PCB4050700KP 46
PCB4050750 42
PCB4050800 42
PCBP69SET 46, 244
PCBR40 43
PCD005 60, 62, 63, 64, 65, 66,
67, 68, 69, 70, 73, 74, 75,
76, 77, 78, 79, 80, 81, 82,
83, 223, 224, 225, 226,
227
PCD008 68, 72
PCFM58 110
PCFM3322 110
PCFM5822 110
PCFX30 109
PCFX35 109
PCFX50 109
PCFX70 109
PCGU2028 108
PCGU2030 47, 61, 71, 93, 146
PCGU2030LB 108
PCGU2049 48, 50, 51, 60, 62,
63, 64, 65, 66, 67, 68, 69,
70, 72, 73, 90, 91, 93, 94,
95, 96, 100, 101, 102, 105,
150, 318, 319
PCGU2049F 104
PCGU2059 74, 75, 76, 77, 78,
79, 80, 81, 82, 83, 94, 98
PCL4349N 108
PCL4834N 108
PCL9434N 108
PCL9449N 108
PCL12549N 108
PCMAS350 335
PCMAS400 335
PCMAS450 335
PCMAS500 335
PCMAS500ML 335
PCMAS550 335
PCMAS600 335
PCMAS600ML 335
PCMAS650 335
PCMAS700 335
PCMAS700ML 335
PCMAS750 335
PCMAS800 335
PCMAS800ML 335
PCMB4 340
PCMB50300H175 45
PCMB50400H175 45
PCMB50500H175 45
PCMB50600H175 45
PCMT150-700 53
PCMT150-750 53
PCMT150-800 53
PCMT150-850 53
PCPF16L6 46, 338
PCPF16L18 46, 338
PCS14 47, 48, 50, 51, 60, 61,
62, 63, 64, 65, 66, 67, 68,
69, 70, 71, 72, 73, 74, 75,
76, 77, 78, 79, 80, 81, 82,
83, 90, 91, 93, 94, 95, 96,
98, 100, 101, 102, 104,
105, 126, 146, 150, 318,
319
PCS14M107SET 126, 127
PCS16TR140SET 141, 142, 150
PCS16TR160SET 141, 142, 150
PCS16TR180SET 141, 142, 150
PCS16TR200SET 141, 142, 146,
150
PCSET18220W2-OPM 286
PCSET18250-OPM 286
PCSP10B 109, 110, 112
PCSP10G 109, 110, 112
PCSP10SET 110
PCSP30L 47, 61, 93, 146
PCSP30R 47, 61, 93, 146
PCSP40L 71
PCSP40R 71
PCSP50L 65, 67, 72, 91, 93, 94,
95, 96, 104, 318
PCSP50LF 68
PCSP50R 65, 67, 72, 91, 93, 94,
95, 96, 104, 318
PCSP50RF 68
PCSP60L 48, 50, 51, 60, 62, 63,
64, 65, 66, 67, 68, 69, 70,
73, 74, 75, 76, 77, 78, 79,
80, 81, 82, 83, 90, 91, 93,
94, 96, 98, 100, 101, 102,
105, 126, 319
PCSP60LG 150
PCSP60R 48, 50, 51, 60, 62, 63,
64, 65, 66, 67, 68, 69, 70,
73, 74, 75, 76, 77, 78, 79,
80, 81, 82, 83, 90, 91, 93,
94, 96, 98, 100, 101, 102,
105, 126, 319
PCSP60RG 150
PCT30P-153-4 52
PCT110-250MATS 54
PCT110-300 53
PCT110-300MATS 54
PCT110-350 53
PCT110-400 53
PCT110-450 53
PCT110-500 53
PCT110-550 53
PCT110-600 53
PCT110-650 53
PCT110-700 53
PCT155-290-3MATS 54
PCU10093 112
PCU14093 112, 232
PCU20018 112
PCU20025 112
PCU20033 112
PCU20042 112
PCU20047 112
PCU20057 112
PCU20060 112
PCU20067 112
PCU20077 112
PCU20077B10 112
PCU20077B10-W 112
PCU20093 112, 232
PCU20124 112, 232
PCU24018 112
PCU24025 112
PCU24033 112
PCU24042 112
PCU24047 112
PCU24057 112
PCU24060 112
PCU24067 112
PCU24077 112
PCU24093 112, 232
PCU24093B10 112
PCU24093B10-W 112
PCU24124 112, 232
PCU29018 112
PCU29025 112
PCU29033 112
PCU29042 112
PCU29047 112
PCU29057 112
PCU29060 112
PCU29067 112
PCU29077 112
PCU29093 112, 232
PCU29093B10 112
PCU29124 112, 232
PCU31018 112

Index

- PCU31025 112
PCU31033 112
PCU31042 112
PCU31047 112
PCU31057 112
PCU31060 112
PCU31067 112
PCU31077 112
PCU31093 112, 232
PCU31093B10 112
PCU31124 112, 232
PCU34018 112
PCU34025 112
PCU34033 112
PCU34042 112
PCU34047 112
PCU34077 112
PCU34093 112, 232
PCU34093B10 112
PCU34124 112, 232
PCU39018 112
PCU39025 112
PCU39033 112
PCU39042 112
PCU39047 112
PCU39077 112
PCU39093 112, 232
PCU39093B10 112
PCU39093B10-W 112
PCU39124 112, 232
PCU44018 112
PCU44025 112
PCU44033 112
PCU44042 112
PCU44047 112
PCU44077 112
PCU44093 112, 232
PCU44093B10 112
PCU44093B10-W 112
PCU44124 112, 232
PCU46033 112
PCU46042 112
PCU46047 112
PCU46093 112, 232
PCU46093B10 112
PCU46093B10-W 112
PCU46124 112
PCU46518 112
PCU46525 112
PCU46533 112
PCU47042 112
PCU47093 112
PCUB60-70-130 51
PCUB60-130 48
PCUB100-200 48
PCUB100-300 48
PCUB115-200-R25 50
PCUB115-300-R25 50
PCUH2594 112
PCUM1409308 111
PCUM2009308 111
PCUM2409308 111
PCUM2909308 111
PCUM3109308 111
PCUM3409308 111
PCUM3909308 111
PCUM4409308 111
PCUM4609308 111
PCUSR14 200
PCWB252594 73
PCWB252594RF 73
PCWB262694 73
PCZ80L40PRG62 123
PCZ100L50 126
PCZB7021PRF 152
PCZB7023PRG 152
PCZB8050UPRG 150, 152
PCZB8060R34 152
PCZB8060R40ALU 152
PCZB10060R50 152
PCZB10060R50ST 152
PCZB12060R34 152
PCZS2439-ID-SET 126, 127
PCZS2439L 126, 127
PCZS2439R 126, 127
PF-SET 85
PR94-39-50 94
PR94-39-50SET 94
PR94-49 94
PR94-49SET 94, 143
PR125-49 94
PR125-49ALU 94
PR125-49SET 94
PR125-49SETALU 94
PR150-49 94
PR150-49SET 94
PRG1003M8 129, 152, 337
PRS50L78ST 96
PRS70L78ST 96
PS1F19N49-20 60
PS1F20L35BV1 101
PS1F20L35BV1NS 101
PS1F25N44-13 61
PS1F26N49-26 62
PS1F34N49-45 63
PS1F43N49-60 51, 64
PS1F43N62-60 64
PS1F48L34-105 76
PS1F48L49-105 79
PS1F48N34-80 65
PS1F48N49-80 66
PS1F58N34-80 65
PS1F68N34-80 65
PS1F78L34-105 77
PS1F78L49-105 77
PS1F78N34-80 67
PS1F78N49-80 67
PS1F78N49-90 69
PS1F94L34-105 81
PS1F94L49-105 81
PS1F94N34-80 67
PS1F94N34-90 68
PS1F94N49-90 68
PS1F125N49-95 70
PS1F-KLD1 100
PS1F-KLD1NS 100
PS1P48L34-105 74
PS1P48L49-105 74
PS1P94L34-105 75
PS1P94L49-105 75
PS1P694L34-105 75
PS1PF48L34-105 74
PS1PF48L49-105 74
PS1PF94L34-105 75
PS1PF94L49-105 75
PS1PV48L34-105 76
PS1PV94L34-105 78
PS1PV94L49-105 78
PS1R19N49-20 60
PS1R25N44-13 61
PS1R26N49-26 62
PS1R34N49-45 63
PS1R43N49-60 64
PS1R43N62-60 64
PS1R48L34-105 76, 77
PS1R48L49-105 79
PS1R48L49-105H20 82
PS1R48N34-80 65
PS1R48N49-80 66
PS1R48N75-80 66
PS1R58N34-80 65
PS1R58N49-80 65
PS1R68N34-80 65
PS1R78L34-105 77
PS1R78L49-105 77
PS1R78N34-80 67
PS1R78N49-80 67
PS1R78N49-90 69
PS1R94L34-105 81
PS1R94L49-105 81
PS1R94L49-105H20 82
PS1R94N34-80 67
PS1R94N34-90 68
PS1R94N49-90 68
PS1R125L49-105H20 83
PS1R125N49-95 70
PS1X50L78ST 96
PS1X50N62-ER32 99
PS1X50N70H-ER32-NS 99
PS1X50N100-ER32 99
PS1X63N100-ER40 99
PS1X68N80-W20 99
PS1X70L78ST 96
PS1X80L31-VAC 319, 321
PS1X100-65ER-036345 104
PS1X150L60-250MAG11 102
PS1X150L60-VAC 103, 318, 321
PS2F61N34-45 72
PS2G94N44-13 71
PS2R61N34-45 72
PS2X94N49-60 73
PS3X80L75BSET 98
PS3X100L82BSET 98
PS3X125L87BSET 98
PS5X19N49-20 60
PS5X26N49-26 62
PS5X34N49-45 63
PS5X43N49-60 64
PS5X48L34-105 80
PS5X48L49-105 79
PS5X48N49-80 66
PS5X94L49-105 81
PS5X94N49-90 68
PS5X125N49-95 70
PSH1X94L49-310 105
PT-F61-25X30 93
PT-F61-25X50 93
PT-F61-25X60 93
PT-F80-30X30NS 93
PT-F80-30X60 93
PT-F80-30X60NS 93
PT-F132-34RD 94
PT-F132-34RDSET 94
PTX80-30 98
PTX100-29 104
PTX100-30 98
PTX125-29 98
PTX160-57S 95
PTX160-77S 95
PTX-MCZ40L30 101
Q
QSG1/4-8 319, 323
QSL-G1/4-8 323
QST-G1/4-8 323
R
RD16M12 338
RD16M1612M12 338
RD18M1612M12 338
RP9431SET 339
RPD504-R50 274
RPQ50504-R50 274
S
SET18ZSP40L38-2 156
SET18ZSP125L85-1 157
SET18ZSP125L110-2 158
SFED6W90 196
SLO 340
SL1 340
SL3 340
SM1135M6X8 322, 338
SM1135M06X10 338
SM1135M08X10 338
SM1135M08X12 338
SM1135M08X14 338
SM1135M10X12 338
SM1135M10X14 338
SM1135M12X14 338
SM1135M12X16 338
SM1135M12X18 338
SM1135M12X20 338
SM1135M12X22 338
SM1135M14X16 338
SM1135M14X18 338
SM1135M16X18 338
SM1135M16X20 338
SM1135M18X20 338
SM1135M18X22 338
SM1135M20X22 338
SM1135M20X24 338
SM1135M24X28 338
SM1136-12 338
SM1136-14 338
SM1136-16 338
SM1136-18 338
SM1136-20 43, 338
Smiley 339
SMK24-24-42OPP200 272
SMK30-17-42OPP200 272
SMK301850R50 253
SMK301855R50 253
SMK301860R50 253
SMK301865R50 253
SMK301870R50 253
SMK301875R50 253
SMK351865R50 255
SMK351870R50 255
SMK351875R50 255
SMK351880R50 255
SMK351885R50 255
SMK351890R50 255
SMK351895R50 255
SMUB2373H220 276
SMUB3373H220 276
T
TB150091 146
TB150092 146
TB160379 301
TB170051 142
TC10 339
TK150057 174
TN100668 326, 327
TN100682 323
Triag Bit 339
Triag Bitburr 339

Index

Triag Ei 340
Triva Bit 324
TS150487 323
TWADAPT10 337
TWADAPT12 337
TWADAPT14 337
TWADAPT16 337
TWADAPT18 337
TWADAPT20 337
TWADAPT22 337
TWPAS1227 338
TWPAS1232 195, 338
TWPAS1240 46, 50, 154, 179, 338
TWPAS1250 338
TWPAS16055 338

U

UA2-260 321, 322
UA3-360 321, 322
UA3-560 321, 322
UA3-660 321, 322
UA0770 321, 322
UA182540 318, 321, 322
UB1-OIL 325
UB5AXMCZ40-35SET4 118
UB5AXMCZ40-35SET8 118
UB5AXMCZ40-45SET8 119
UB5AXMCZ40-45SET8-ER 119
UB5AXMCZ4035SET4 118
UB5AXMCZ4035SET8 118
UB5AXMCZ4045SET4 119
UB5AXMCZ4045SET4-ER 119
UB5AXMCZ4045SET8-OPBM 286
UB5AXMCZ4045SET8-OPMB 119
UB5AXSET18-3 122
UBA106110250 321, 325
UBA106230300 321, 325
UBA118230600 325

UBA306400250 325
UBA318400550 321, 325
UBS5045 326
UBT40 325
UF15030050R50 317, 321
UF20030050R50 316, 321
UF30060050R50 315, 321
UF50050050R50 314, 321
UP15030040R50G06 317, 320, 321
UP15030040R50G13 317, 321
UP20030040R50G06 316, 320, 321
UP20030040R50G13 316, 321
UP30060040R50G06 315, 320, 321
UP30060040R50G13 315, 321
UP50050040R50G06 314, 320, 321
UP50050040R50G13 314, 321
UPB1JN 321, 327
UPB2JN 321, 327
US150300 317
UT1003040 318, 321, 322
UZA4012G06 321, 322
UZA5015G13 321, 322
UZV16301/4SET 323
UZV16301/4SET-90° 323
UZV16301/4SET-T 323

V

VA168-20PRG 199
VFP08040L90 (Ø 4 mm) 324
VFP10065L100 (Ø 6,5 mm) 324
VS1F19N35-20 186
VS1F41L30-51 198
VS1F41N30-60 189
VS1F48L50-105 200
VS1F80L30-51 201
VS1F80N30-36 190
VS1F80N30-60 191

VS1F125N49-95 193
VS1P48L50-105 200
VS1R19N35-20 186
VS1R26L35-31 197
VS1R26N35-26 187
VS1R38N50-60 188
VS1R41L30-51 198
VS1R41N30-60 189
VS1R80L30-51 201
VS1R80N30-36 190
VS1R80N30-60 191
VS1R80N50-36 190
VS1R80N50-60 192
VS1R125N49-95 193
VS1X59L60H5 203
VS1X59L60K 202
VS1X68L20-105 199
VS2F90N30-60 195
VS2R80N30-60 194

W

WU-18 288
WU-25 288

Z

ZB150786 141
ZB150787 141
ZB150791 150
ZB150792 150
ZB170050 142
ZF211785 286, 287
ZF222333 287
ZK160798M5 129
ZSB140L50 150, 151
ZSB160L50 150, 151
ZSB180L50 150, 151
ZSB200L50 150, 151
ZSM140L50 115, 143, 144
ZSM160L50 143, 144
ZSM170L65GH200PCB 145, 146
ZSM180L50 143, 144

ZSM200L50 139, 143, 144
ZSM300L50 144
ZSMB250L82 147
ZSMB500L112 147
ZSP40L38-2 156
ZSP125L85-1 157, 159
ZSP150L100 160
ZSP200L100 160
ZSP250L100 160
ZSQ160L50UPRG 148
ZSQ180L50UPRG 148
ZSQ200L50UPRG 148
ZSQ160L50UPRG 148
ZSQP180L50UPRG 148
ZSQP200L50UPRG 148
ZSQP300L50UPRG 148
ZSX140L50PRG120 142
ZSX140L50UPRG 141, 283
ZSX140L50UPRG-OPM 286
ZSX160L50PRG120 142
ZSX160L50UPRG 141
ZSX160L50UPRG-OPM 286
ZSX180L50PRG120 142
ZSX180L50UPRG 141
ZSX180L50UPRG-OPM 286
ZSX200L50PRG120 142
ZSX200L50UPRG 141, 154
ZSX200L50UPRG-OPM 286

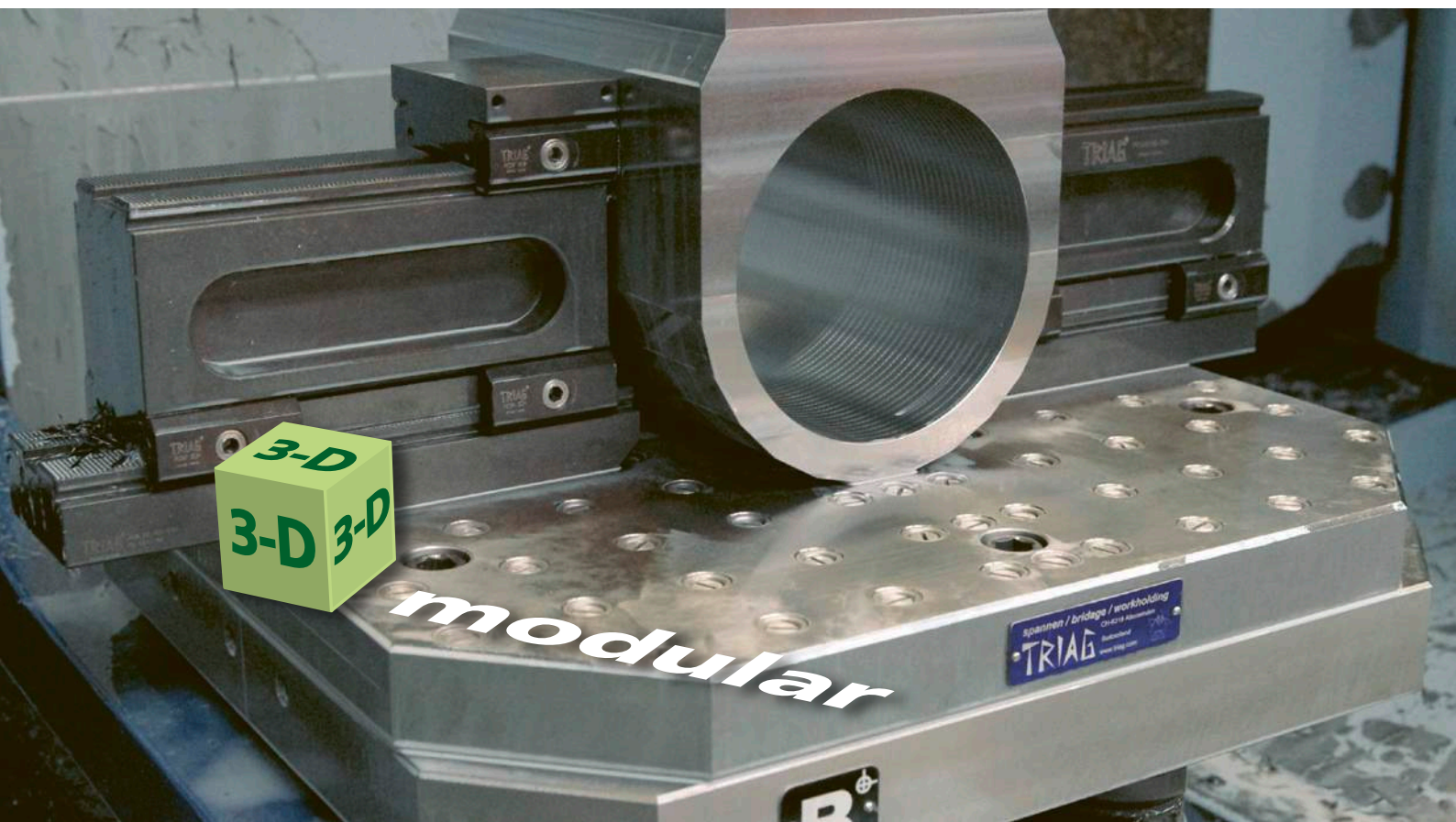

Produktion einer Werkstück Familie
Producing a complete workpiece family

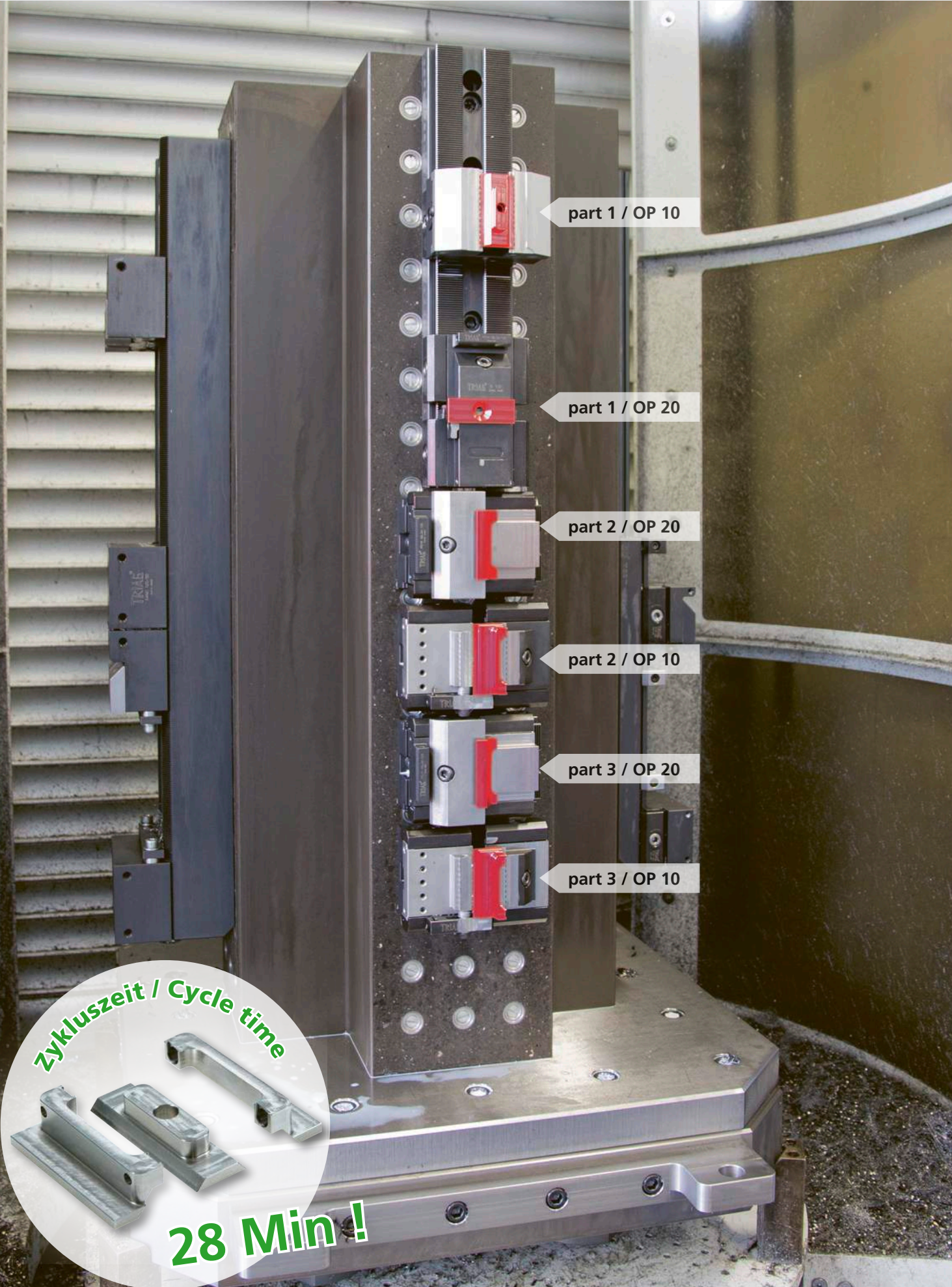

Zykluszeit / Cycle time

28 Min !

A circular inset image showing three different metal workpieces. The text 'Zykluszeit / Cycle time' is written in green above the workpieces, and '28 Min !' is written in green below them. The workpieces are made of metal and have various shapes, including a long thin piece, a shorter wider piece, and a more complex piece with a hole.



powerCLAMP & 5axes

Das schnellstverstellbare Mehrfachspannsystem! Die Positionierung der Spannmodule erfolgt mittels einer Verzahnung auf der Schiene. Befestigung mit nur einer Schraube!

powerCLAMP & 5axes

The quickest multiple workholding system for easy set up! Positioning of the clamping modules by teeths on the base rail. Repositioning by opening only one single screw!



triCENTRO

Kleine bis grosse, sowie modulare Zentrischspanner in verschiedenen Ausführungen.

triCENTRO

Small to big modular self centering vises in different variations.



microCLAMP

Kleinste Module für den Vorrichtungsbau. Sie haben eine grosse Spannkraft (bis 28'000N), der benötigte Abstand zwischen den Werkstücken ist im Optimalfall nur 15 mm.

microCLAMP

Smallest modules for dedicated fixtures. Having a high clamping force (up to 28'000N) the distance between workpieces is only 15 mm in optimum set up.

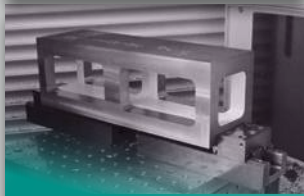

aptoCLAMP & 5axes

Die hohe Spannkraft dieses Systems ermöglicht den Einsatz für schwere Zerspanung.

aptoCLAMP & 5axes

The high clamping force of the aptoCLAMP enables heavy cuts.



tripoxyMINERAL

Spanntürme aus Mineralguss. Die Vibrationsdämpfung ist zehnmal besser als bei Grauguss. Das spezifische Gewicht ist hingegen kleiner als bei Aluminium. Erhältlich in vielen verschiedenen Formen.

tripoxyMINERAL

Tombstones made of composite concrete. Vibration damping effect is ten times better than with cast iron. Specific weight on the other hand is less than aluminium. Available in many different shapes.



oppSystem & 5axes

Unser Nullpunkt-Palettiersystem ermöglicht ein genaues Positionieren von Mehrfachspannsystemen, Schraubstöcken und Vorrichtungen auf Maschinentischen oder Spanntürmen.

oppSystem & 5axes

Our zero-point palleting system allows exact positioning of multiple workholding systems, vices and dedicated fixtures on machining tables or tombstones.



trivaCLAMP

Vakuumspannsystem: Bestens geeignet für plattenförmige Werkstücke (auch nicht magnetische). Es können sowohl Druckstellen als auch Deformationen an labilen Teilen vermieden werden.

trivaCLAMP

Workholding by vacuum: Suited for plateshaped workpieces (also for non magnetical). Pressure marks as well as deformations on soft parts can be avoided.



triGEL

Unser Gefrierspannsystem. Sehr gut geeignet für unförmige Teile. Es erlaubt mehrseitiges Bearbeiten ohne Neuspannen. Das Haftvermögen ist sehr gross, wobei die Gefrier- und Auftauzeiten sehr gering sind.

triGEL

Workholding by freezing: Well suited for strangely shaped parts. It allows processing from more than one side without unclamping. Holding effects are very strong whereas freezing and defrosting times are very short.

swiss MODULAR[®]



Triag International AG

Bösch 84 CH-6331 Hünenberg

+41 41 727 27 77

spannen@triag-int.ch

clamping@triag-int.ch

TRIAG INTERNATIONAL

swissmodular.com

Official Website

